

VCR standard audio signal processor

BA7797F

The BA7797F is standard audio signal processor designed for use in VCRs and tape decks. The circuit is comprised of a playback preamplifier, a line amplifier, a recording amplifier, an ALC circuit and high-voltage head switch. The IC has a built-in coil equivalent circuit for recording equalization, which eliminates the need for an external component.

●Applications

Video cassette recorders and tape decks

●Features

- 1) Two input switching systems built-in (LINE and TUNER).
- 2) Built-in coil equivalent circuit for recording equalization.
- 3) High-performance low-noise playback amplifier.
- 4) ALC level can be adjusted by connection of an external resistor.
- 5) Compatible with single-mode EQ making it ideally suited to widely-used decks.

●Block diagram

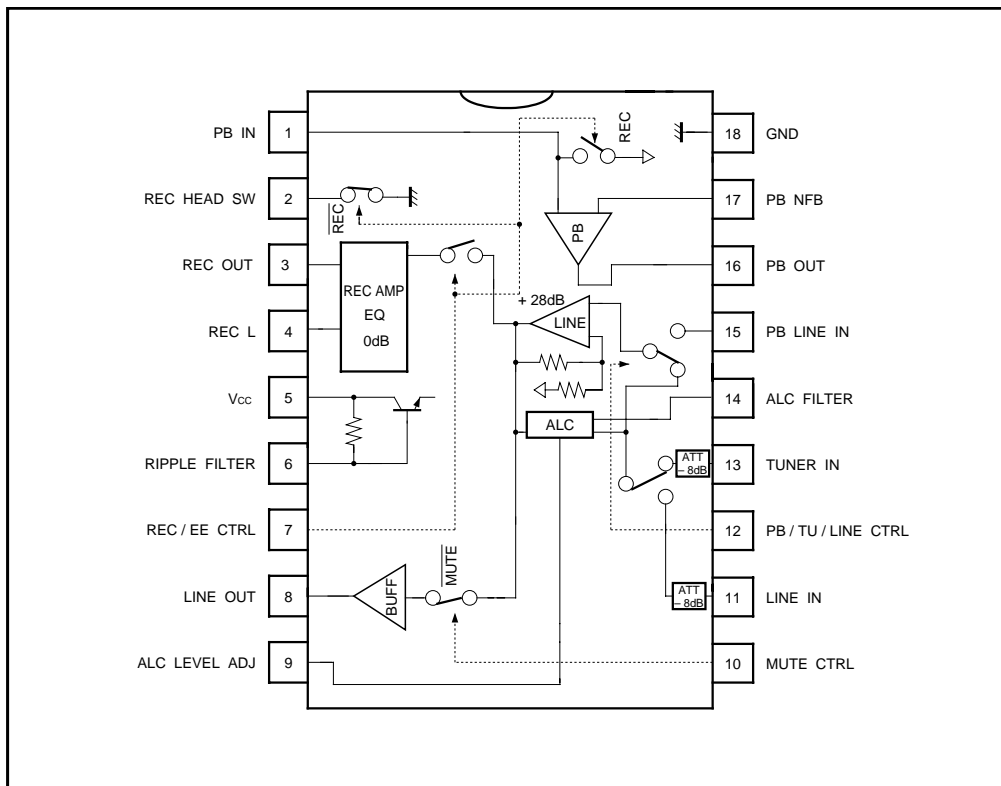

● Absolute maximum ratings (Ta = 25°C)

Parameter	Symbol	Limits	Unit
Power supply voltage	V _{CC}	13	V
Power dissipation	P _d	550*	mW
Operating temperature	T _{opr}	- 10 ~ + 65	°C
Storage temperature	T _{stg}	- 55 ~ + 125	°C

* When mounted on a 50mm × 50mm × 1.6mm glass epoxy board. Reduced by 5.5mW for each increase in Ta of 1°C over 25°C.

● Recommended operating conditions (Ta = 25°C)

Parameter	Symbol	Min.	Typ.	Max.	Unit
Power supply voltage	V _{CC}	7.5	—	12.5	V

● Pin descriptions (V_{CC} = 10V)

Pin No.	Pin name	Function	Pin voltage	I / O circuit
1	PB IN	Playback amplifier input / playback head switch	2.0V	REC: 120kΩ REC: 11Ω
2	REC HEAD SW	High-withstanding voltage recording head switch	0.0V	REC: 17Ω (ON) REC: OPEN
3	REC OUT	Recording amplifier output	4.7V	EF (P-P)
4	REC L	Recording EQ switch	4.7V	B (NPN)
5	V _{CC}	V _{CC}	10.0V	—
6	RIPPLE FILTER	Ripple filter	10.0V	10kΩ (V _{CC})
7	REC / EE CTRL	REC / EE control	—	See input / output circuit
8	LINE OUT	Line amplifier output	4.7V	EF (P-P)
9	ALC LEVEL ADJ	ALC level adjustment	4.1V	See Fig. 4
10	MUTE CTRL	Mute control	—	See input / output circuit
11	LINE IN	Line input	4.7V	120kΩ
12	PB / TU / LINE CTRL	PB / TU / LINE control	—	See input / output circuit
13	TUNER IN	Tuner input	4.7V	120kΩ
14	ALC FILTER	For setting the time constant for the ALC filter (attack and recovery times)	PB: 0.0V PB: Not fixed	EF (NPN) ~ 100Ω
15	PB LINE IN	Line input for playback	4.7V	120kΩ
16	PB OUT	Playback amplifier output	2.0V	EF (P-P)
17	PB NFB	Playback amplifier feedback	2.0V	B (NPN)
18	GND	GND	0.0V	—

* EF: emitter follower, P-P: push pull, B: base, and C: collector.

All measurements made using the measurement circuit (Fig.1) with V_{CC} = 10V and quiescent circuit conditions.

All numerical values are standardized values.

●Input / output circuits

REC / EE CTRL 7

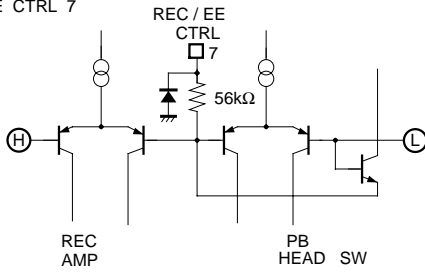

MUTE CTRL 10

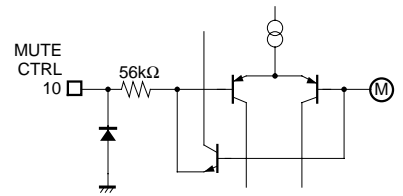

PB / TU / LINE CTRL 12

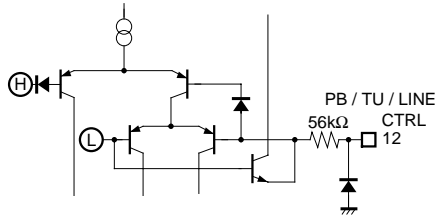

●Electrical characteristics (unless otherwise noted, $T_a = 25^\circ\text{C}$, $V_{CC} = 10\text{V}$, and $f = 1\text{kHz}$)

Parameter	Symbol	Min.	Typ.	Max.	Unit	Conditions	Measurement circuit
Quiescent current EE	I_{qEE}	6.4	8.5	11.3	mA	No signal	Fig.1
Quiescent current PB	I_{qPB}	6.4	8.5	11.3	mA	No signal	Fig.1
Quiescent current REC	I_{qREC}	5.2	6.9	9.2	mA	No signal	Fig.1
〈Line amplifier〉							
Voltage gain (PB input)	G_{VCLP}	27.0	28.0	29.0	dB	$V_o = -8\text{dBV}$	Fig.1
Voltage gain (LINE1, LINE2, TU inputs)	G_{VCLT}	19.0	20.0	21.0	dB	$V_o = -8\text{dBV}$	Fig.1
Distortion	THD_{LT}	—	0.1	0.3	%	$V_o = -8\text{dBV}$, $R_L = 4.7\text{k}\Omega^*$	Fig.1
Maximum output level	V_{OMLT}	5.9	8.4	—	dBV	THD = 1%, $R_L = 4.7\text{k}\Omega^*$	Fig.1
Output residual noise	V_{NOLT}	—	-81.5	-75	dBV	$R_g = 4.7\text{k}\Omega$, DIN AUDIO	Fig.1
ALC level	V_{OA}	-9.0	-8.0	-7.0	dBV	$V_{IN} = -25\text{dBV}$, 9pin: OPEN	Fig.1
ALC distortion	THD_A	—	0.1	0.5	%	$V_{IN} = -25\text{dBV}$, $R_L = 4.7\text{k}\Omega^*$	Fig.1
Mute attenuation ratio	MT	—	-82.0	-72	dB	$V_o = 0\text{dBV}$, DIN AUDIO	Fig.1
〈Recording amplifier〉							
Voltage gain	G_{VCR}	19.0	20.0	21.0	dB	LINE IN, TUNER IN→REC OUT	Fig.1
Distortion	THD_R	—	0.13	0.4	%	$V_o = -8\text{dBV}$	Fig.1
Maximum output level	V_{OMR}	5.7	8.2	—	dBV	$V_o = -8\text{dBV}$, $R_L = 4.7\text{k}\Omega^*$	Fig.1
Openloop gain	G_{VOR}	60	71	—	dB	THD = 1%, $R_L = 4.7\text{k}\Omega^*$	Fig.1
Playback preamplifier							
Openloop gain	G_{VOP}	61	68	—	dB		Fig.1
Input conversion noise	V_{NINP}	—	-122.5	-114	dBV	$R_g = 680\Omega$, DIN AUDIO	Fig.1
Voltage gain (stand alone)	G_{VCP}	35.0	36.0	37.0	dB	PB IN→PB OUT	Fig.1
〈Head switch〉							
PB head switch impedance	R_{PH}	—	11	20	Ω		Fig.1
REC head switch impedance	R_{RH}	—	17	25	Ω		Fig.1
REC head switch DC withstanding voltage	BV_{RHDC}	—	0	10	μA	$E_2 = \pm 55\text{V}$	Fig.1
REC head switch AC withstanding voltage	BV_{RHAC}	80	100	—	V_{P-P}	$f = 70\text{kHz}$, $V_2 \leq \pm 1.5\text{V}$	Fig.2

* Measured at BW = 400Hz to 30kHz.

● Measurement circuits

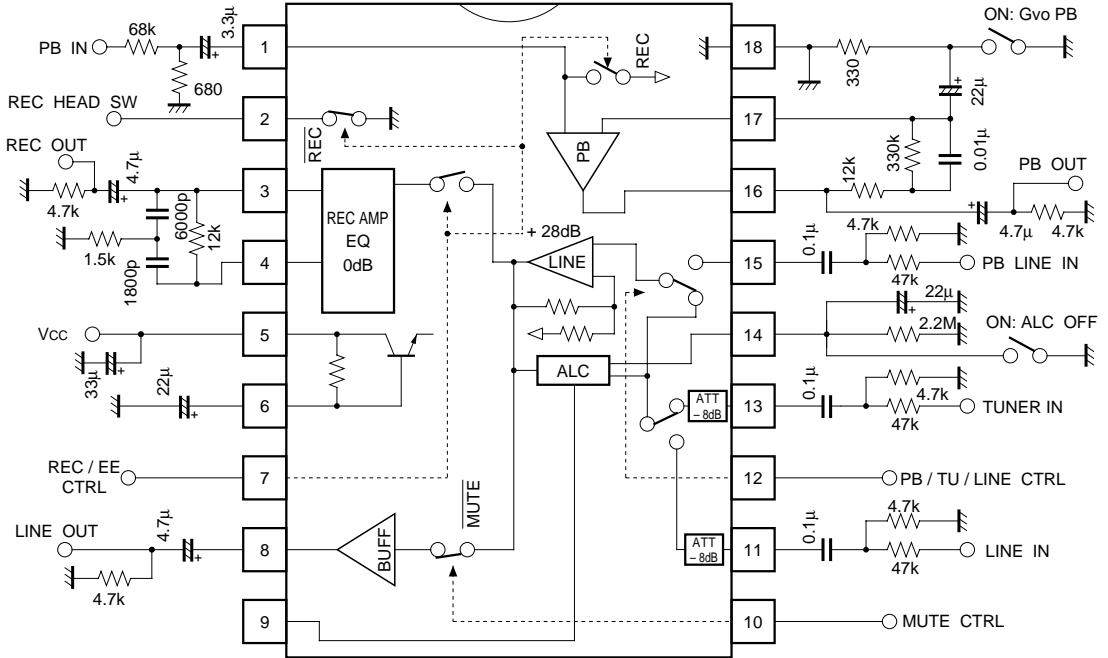
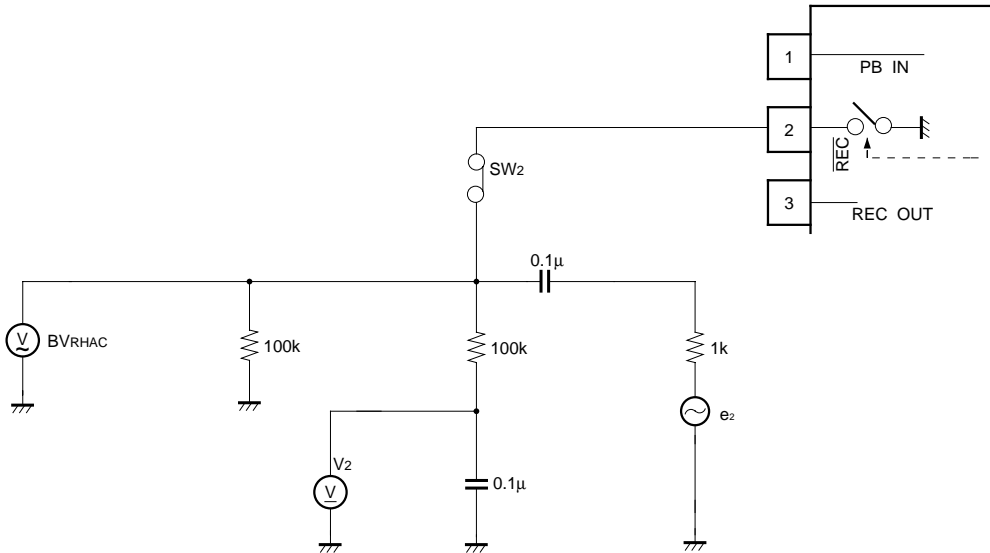

Fig. 1

Units: R [Ω]
C [F]



REC head switch AC withstanding voltage measurement circuit

Fig. 2

●Control mode table

(1) REC / EE control, PB / TU / LINE control

Control pins		Mode	Function			
REC / EE	PB / TU / LINE		PB HSW	REC HSW	LINE SW	REC AMP
L	L	LINE	OFF	ON	LINE	OFF
L	M	TUNER	OFF	ON	TUNER	OFF
L	H	PB	OFF	ON	PB	OFF
H	L	LINE REC	ON	OFF	LINE	ON
H	M	TU REC	ON	OFF	TUNER	ON
H	H	inhibit	—	—	—	—

If REC / EE CTRL is set to "M", the REC pause state is possible (REC head switch: open, REC amplifier: off).

(2) Mute control

Control pins	Mode	Function
MUTE		LINE SW
H	MUTE	OPEN
L	MUTE	CLOSE

●Application example

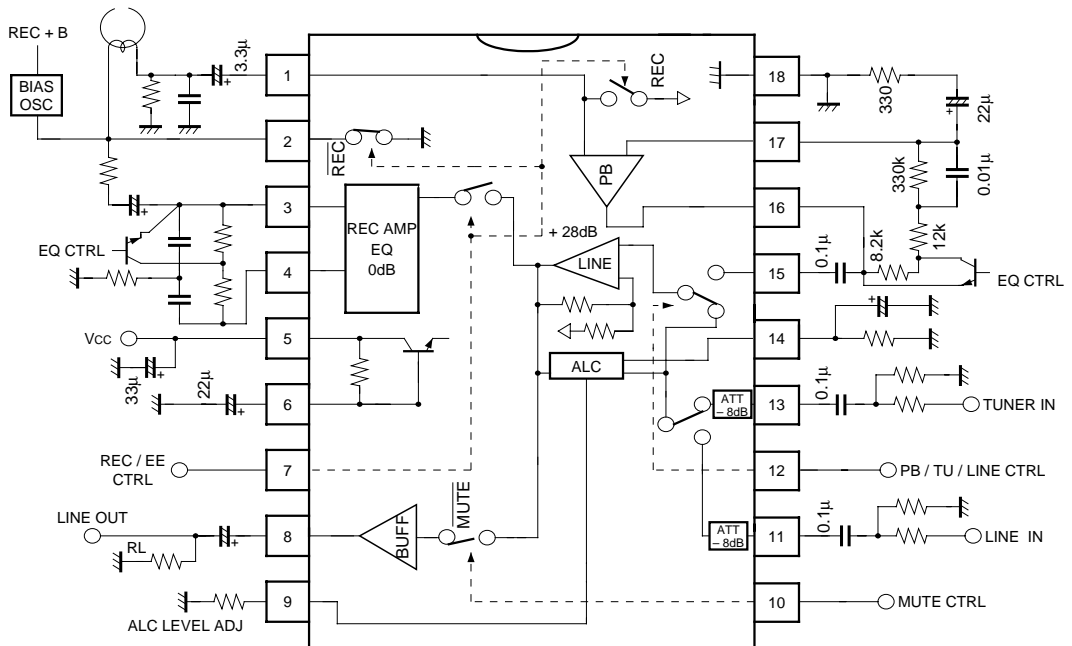

Units: R [Ω]
C [F]

Fig.3

●Operation notes

(1) ALC level

Set the ALC level in the range -8dBV to 0dBV by connecting a resistor between pin 9 and GND.

$$V_{OA} = \frac{1}{\sqrt{2}} \cdot \frac{V_{CC} - 0.7}{2} \cdot \frac{4k}{4k + 32k \times R / (32k + R)}$$

$$= \frac{1}{\sqrt{2}} \cdot \frac{4k}{4k + 32k \times R / (32k + R)} \cdot V_{BIAS}$$

The formula for approximating the value of this resistor is as follows:

When pin 9 is open, V_{OA} is preset to -8dBV (for $V_{CC} = 10V$).

Note that the supply voltage V_{CC} has an effect.

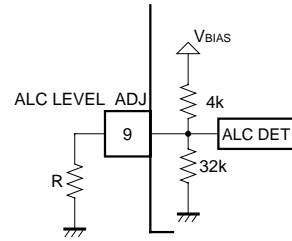
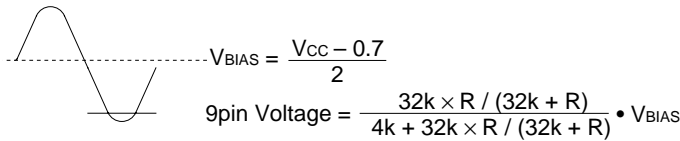

Fig.4



(2) Mute signal

Apply the mute signal shown below at power on and off. If the muting time is short, a “pop” sound will be audible, particularly when the power is switched on.

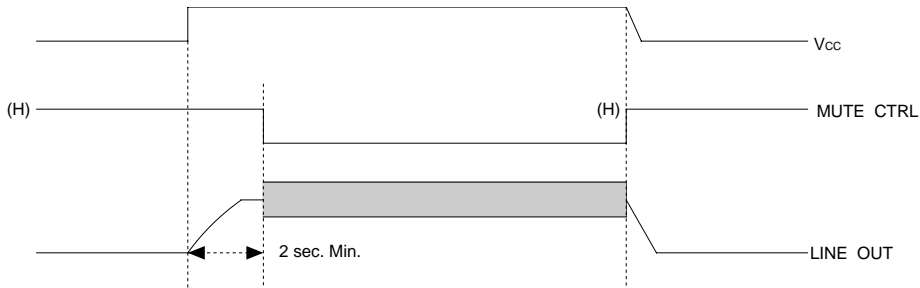

Fig.5

Also, be certain to apply the mute signal when switching between PB / LINE / TU. In the case of LINE / TU switching, it is possible to suppress switching noise by applying a time constant to the signal, in which case it is not necessary to apply the mute signal.

(3) Recording control

Do not switch the PB and REC modes on together. This will cause faulty operation.

(4) Line output

The line output can drive a load resistance of up to 2kΩ. Depending on the type of load, it can cause local oscillation (eg. large capacitive loads that draw large current), so caution is required. In particular, when there is a possibility that the line output will be connected to a shielded cable, or line cable, connect a resistor of about 1kΩ in series with the output so that the capacitive load is not directly coupled to the IC output terminal.

●Electrical characteristic curves

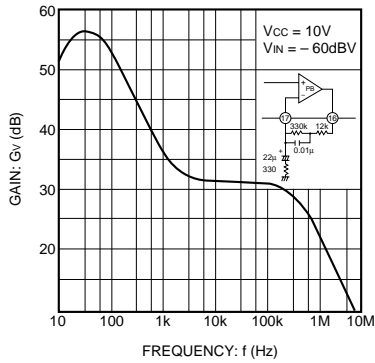

Fig. 6 Gain vs. frequency (PB amplifier)

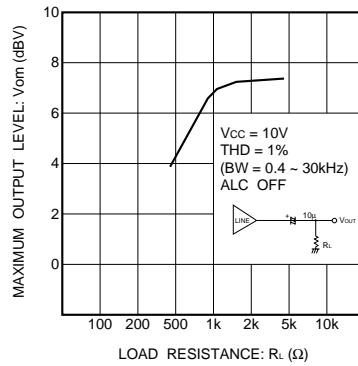

Fig. 7 Line amplifier load drive characteristics

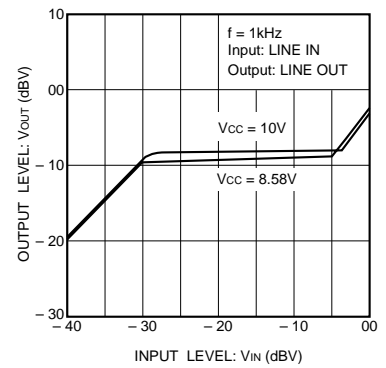

Fig. 8 ALC input / output characteristics

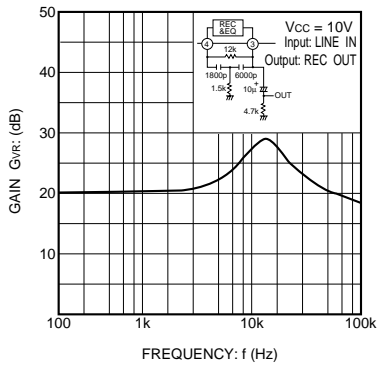

Fig. 9 Gain vs. frequency (REC amplifier)

●External dimensions (Units: mm)

