



## A7240

## LINEAR INTEGRATED CIRCUIT

### 20W BRIDGE AMPLIFIER FOR CAR RADIO

#### DESCRIPTION

The UTC **A7240** is a 20W bridge audio amplifier IC and designed for car radio applications.

A comprehensive array of on-chip protection, include protection against AC and DC output short circuits (to ground and across the load), load dump transients, and junction over temperature, is feature to provide reliable operation. Furthermore, the UTC **A7240** protects the loudspeaker when one output is short-circuited to ground.

#### FEATURES

- \* Few External Components
- \* Output Protected Against short Circuits to Ground and Across Load
- \* Dump Transient
- \* Thermal Shutdown
- \* Loudspeaker Protection
- \* High Current Capability
- \* Low Distortion/Low Noise

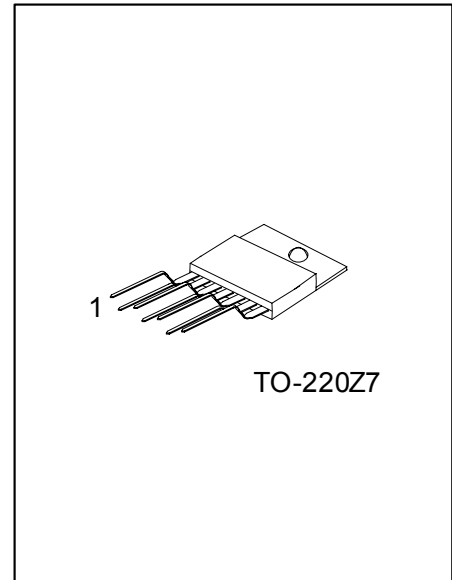

\*Pb-free plating product number: A7240L

#### ORDERING INFORMATION

Order Number		Package	Packing
Normal	Lead Free Plating		
A7240-TB7-T	A7240L-TB7-T	TO-220Z7	Tube

<p>A7240L-TB7-T</p>	<p>(1)Packing Type (2)Package Type (3)Lead Plating</p>	<p>(1) T: Tube (2) TB7: TO-220Z7 (3) Lead Free Plating Blank: Pb/Sn</p>
---------------------	--	---

### ■ PIN CONFIGURATION

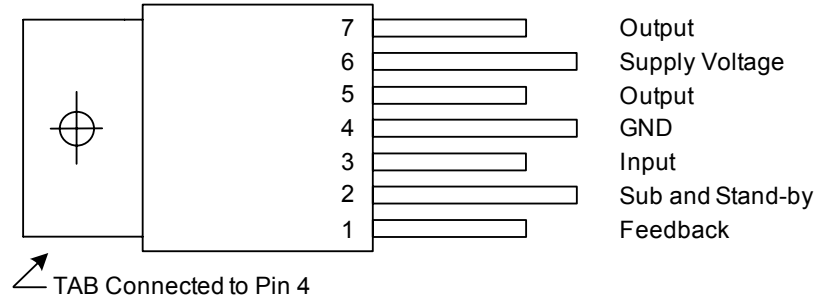

## ■ ABSOLUTE MAXIMUM RATINGS

PARAMETER	SYMBOL	RATINGS	UNIT
Operating Supply Voltage	$V_{SS}$	18	V
DC Supply Voltage	$V_{SS}$	28	V
Peak Supply Voltage (for 50ms)	$V_{SS(PEAK)}$	40	V
Peak Output Current (non repetitive t = 0.1ms)	$I_{O(PEAK)}^{(*)}$	4.5	A
Peak Output Current (repetitive f .10Hz)	$I_{O(PEAK)}^{(*)}$	3.5	A
Power Dissipation at $T_C = 85^{\circ}C$	$P_D$	16	W
Storage and Junction Temperature	$T_{STG}, T_J$	-40~+150	$^{\circ}C$

Note Absolute maximum ratings are those values beyond which the device could be permanently damaged.

Absolute maximum ratings are stress ratings only and functional device operation is not implied.

(\*) Internally limited

## ■ THERMAL DATA

PARAMETER	SYMBOL	RATINGS	UNIT
Thermal Resistance Junction-case	$\theta_{JC}$	4	V

## ■ ELECTRICAL CHARACTERISTICS ( $T_a = 25^{\circ}C$ , $R_{TH}$ (heatsink)= $4^{\circ}C/W$ , $V_{SS} = 14.4V$ )

PARAMETER	SYMBOL	TEST CONDITIONS	MIN	TYP	MAX	UNIT	
Supply Voltage	$V_{SS}$				18	V	
Output Offset Voltage	$V_{O(OFF)}$				150	mV	
Total Quiescent Current	$I_Q$	$R_L = 4\Omega$		65	120	mA	
Output Power	$P_{OUT}$	f = 1kHz, d = 10%	$R_L = 4\Omega$	18	20	W	
			$R_L = 8\Omega$	10	12		
Distortion	THD	f = 1kHz, $P_{OUT} = 50MW \sim 12W$	$R_L = 4\Omega$		0.1	0.5	%
			$R_L = 8\Omega$		0.05	0.5	
Voltage Gain	$G_V$	f = 1KHz	39.5	40	40.5	dB	
Supply Voltage Rejection	SVR	f = 100Hz, $R_g = 10K\Omega$	35	40		dB	
Total Input Noise	eN	$R_g = 10K\Omega$	B = Curve A		2	$\mu V$	
			B = 22Hz~22KHz		3		10
Efficiency	$\eta$	$R_L = 4\Omega$ , f = 1KHz		65		%	
Input Resistance	$R_{IN}$	f = 1kHz	70			k $\Omega$	
Input Sensitivity	$V_{IN}$	f = 1kHz, $P_{OUT} = 2W$ , $R_L = 4\Omega$		28		mV	
Frequency Roll Off (-3dB)	Low	$f_L$	$P_{OUT} = 15W$ , $R_L = 4\Omega$	88		129	Hz
	High	$f_H$		25			kHz
Stand-by Threshold	$V_{THD(PIN2)}$				1	V	
Stand-by Current	$I_{STN-BY}$			200		$\mu A$	
Stand-by Attenuation	$A_{STN-BY}$	$V_{OUT} = 2V_{rms}$	70	90		dB	

## ■ TEST AND APPLICATION CIRCUIT

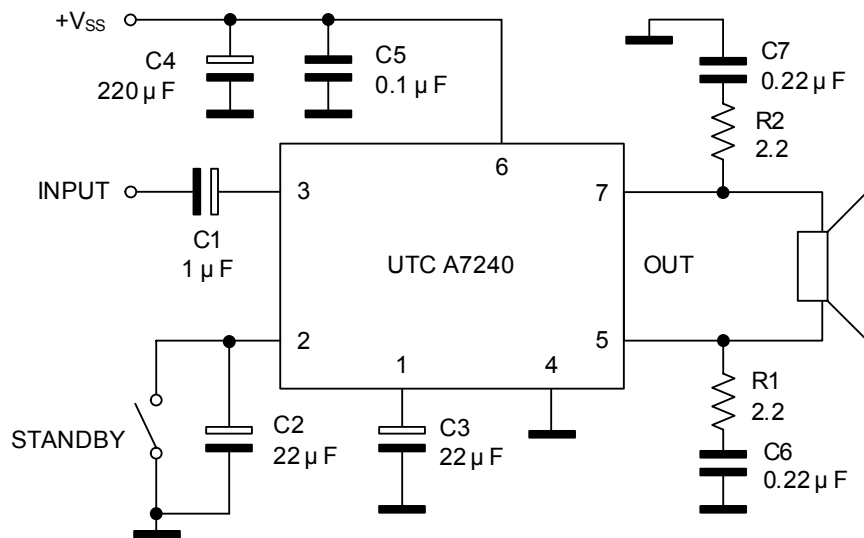

### COMPONENT USAGE SUGGESTION

Component	Suggest	Purpose	Larger than	Smaller than
R1, R2	2.2W	Frequency Stability	Danger of High Frequency Oscillation	
C1	1 μ F	Input DC Decoupling	Higher Turn On and Stand-by Delay	Higher Turn On Pop. Higher Low Frequency Cutoff
C2	22 μ F	Ripple Rejection	Increase of SVR Increase of the Turn On Delay	Degradation of SVR
C3	22 μ F	Feedback low Frequency Cutoff		Higher Low Frequency Cutoff
C4	220 μ F	Supply Filter		Danger of Oscillation
C5	0.1 μ F	Supply Bypass		Danger of Oscillation
C6, C7	0.22 μ F	Frequency Stability		Danger of Oscillation

## TYPICAL CHARACTERISTICS

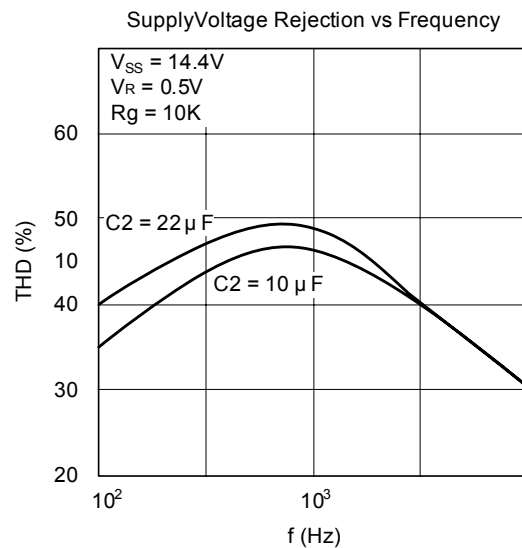
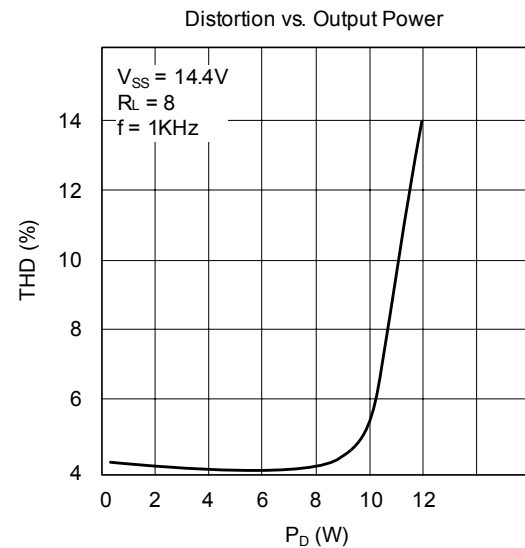
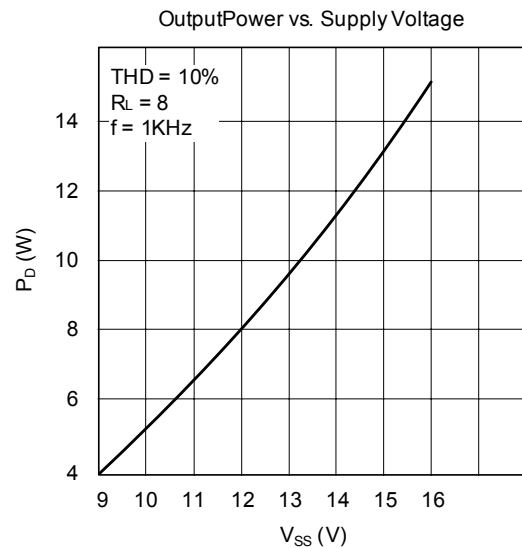
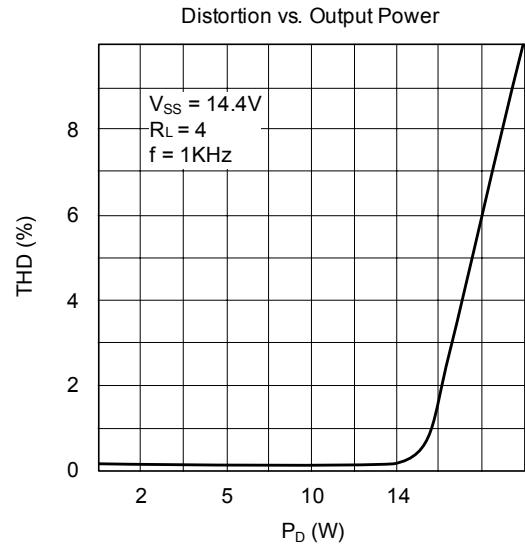
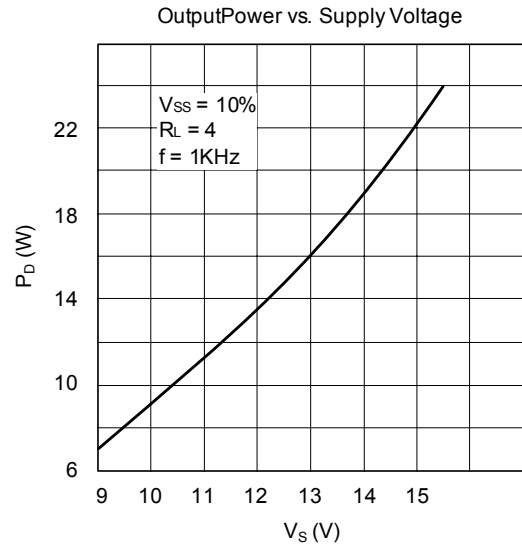

UTC assumes no responsibility for equipment failures that result from using products at values that exceed, even momentarily, rated values (such as maximum ratings, operating condition ranges, or other parameters) listed in products specifications of any and all UTC products described or contained herein. UTC products are not designed for use in life support appliances, devices or systems where malfunction of these products can be reasonably expected to result in personal injury. Reproduction in whole or in part is prohibited without the prior written consent of the copyright owner. The information presented in this document does not form part of any quotation or contract, is believed to be accurate and reliable and may be changed without notice.