

# KH600

## 1GHz, Differential Input/Output Amplifier

### Features

- DC - 1GHz bandwidth
- Fixed 14dB (5V/V) gain
- 100Ω (differential) inputs and outputs
- -74/-64dBc 2nd/3rd HD at 50MHz
- 45mA output current
- 9V<sub>pp</sub> into 100Ω differential load
- 13,000V/μs slew rate
- Optional supply current and offset voltage adjustment

### Applications

- ATE systems
- High-end instrumentation
- High bandwidth output amplifier
- Differential buffer
- Line driver

### General Description

The KH600 is the first amplifier to combine differential input and output with a bandwidth of DC-1GHz at 2V<sub>pp</sub>. The inputs and outputs are 100Ω differential (50Ω single ended). The KH600 operates from ±5V supplies and offers a fixed gain of 14dB (5V/V).

The KH600 also offers optional supply current, differential output offset voltage, and common mode offset voltage adjustments.

The KH600 is constructed using Fairchild's in-house thin film resistor/bipolar transistor technology. The KH600 is available in a 12-pin TO8 package.

### Typical Application

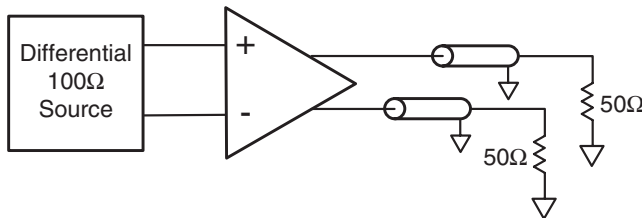

The KH600 includes 50Ω resistors from each input to ground (resulting in a differential input impedance of 100Ω).

Single Tone Intercept Point

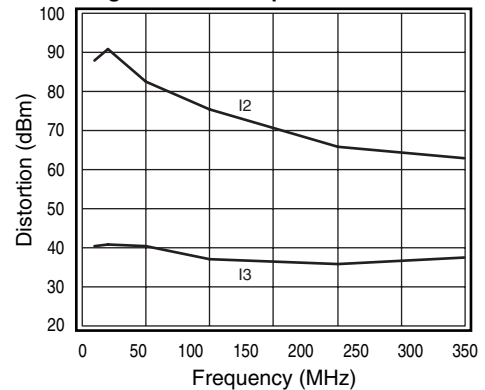

2nd and 3rd Harmonic Distortion

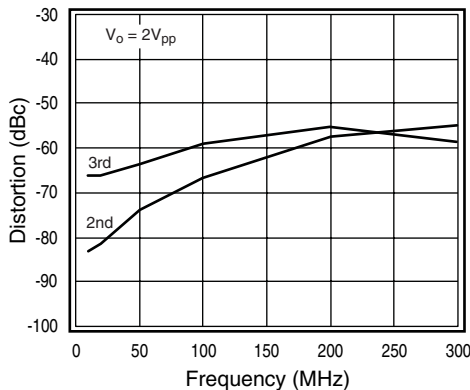

5V<sub>pp</sub> Pulse Response

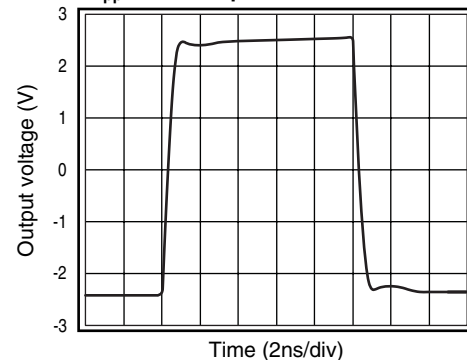

# KH600 Electrical Characteristics

(G = +5V/V (14dB), R<sub>L</sub> = 100Ω (differential), T<sub>a</sub> = +25°C, +V<sub>b1</sub> = +V<sub>b2</sub> = +V<sub>s</sub> = +5V, -V<sub>b</sub> = -V<sub>s</sub> = -5V; unless noted)

Parameters	Conditions	TYP	Min & Max	UNITS	NOTES
Case Temperature		+25°C	+25°C		
<b>Frequency Domain Response</b>					
-3dB bandwidth	V <sub>O</sub> = 2V <sub>pp</sub> DC to 250MHz	1000		MHz	
peaking	DC to 500MHz	0.2		dB	
full power bandwidth	V <sub>O</sub> = 8V <sub>pp</sub> DC to 500MHz	0.5		dB	
linear phase deviation	1MHz	350		MHz	
gain	DC	3		deg	
input return loss (single-ended 50Ω)	DC = 250MHz	14	±0.1	dB	1
	DC = 500MHz	22		dB	
output return loss (single-ended 50Ω)	DC = 500MHz	14		dB	
		27		dB	
<b>Time Domain Response</b>					
rise and fall time	2V step	350		ps	
	8V step	1		ns	
overload recovery	V <sub>in</sub> = 4V <sub>pp</sub>	900		ps	
slew rate	8V step	13,000		V/μs	
<b>Distortion and Noise Response</b>					
2nd harmonic distortion	5V <sub>pp</sub> , 50MHz	61		dBc	
	2V <sub>pp</sub> , 50MHz	74	61	dBc	1
	1V <sub>pp</sub> , 200MHz	65		dBc	
3rd harmonic distortion	5V <sub>pp</sub> , 50MHz	46		dBc	
	2V <sub>pp</sub> , 50MHz	64	57	dBc	1
	1V <sub>pp</sub> , 200MHz	70		dBc	
input referred noise	>1MHz	1.35		nV/√Hz	
noise figure		6.5		dB	
<b>DC Performance</b>					
output offset voltage	I/O's terminated into 50Ω to GND	-18	±60	mV	1
average drift		200		μV/°C	
power supply rejection ratio (±V <sub>s</sub> )	DC	55		dB	
supply current	±V <sub>s</sub> pins	67	70	mA	1
	±V <sub>b</sub> pins (+V <sub>b1</sub> shorted to +V <sub>b2</sub> )	22	24	mA	1
<b>Output Characteristics</b>					
output voltage swing	differential	9		V <sub>pp</sub>	
output current		±45		mA	
<b>Recommended Operating Conditions</b>					
total supply voltage	(+V <sub>s</sub> to -V <sub>s</sub> )	4 to 12		V	
-V <sub>b</sub>		0 to -12		V	
+V <sub>b1</sub> , +V <sub>b2</sub>		0 to 12		V	
input voltage (relative to gain)		±2		V	

Min/max ratings are based on product characterization and simulation. Individual parameters are tested as noted. Outgoing quality levels are determined from tested parameters.

**NOTES:**

1) 100% tested at 25°C.

## Absolute Maximum Ratings

total supply voltage	15V
maximum junction temperature	+150°C
storage temperature range	-65°C to +150°C
lead temperature (10 sec)	+300°C

## KH600 Package

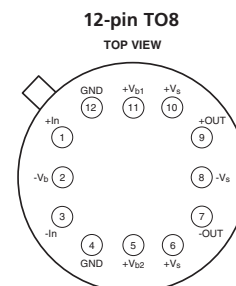

NOTE: Case is grounded.

# KH600 Performance Characteristics

( $G = +5V/V$  (14dB),  $R_L = 100\Omega$  (differential),  $T_a = +25^\circ C$ ,  $+V_{b1} = +V_{b2} = +V_s = +5V$ ,  $-V_b = -V_s = -5V$ ; unless noted)

**Small Signal AC Response ( $S_{21}$ )**

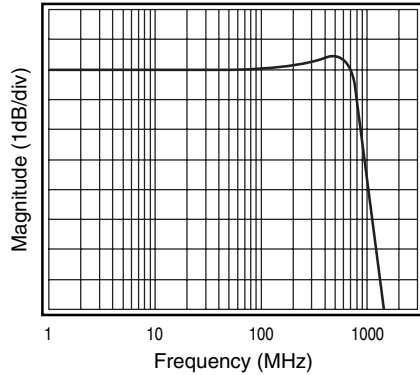

**Input and Output Return Loss ( $S_{11}/S_{22}$ )**

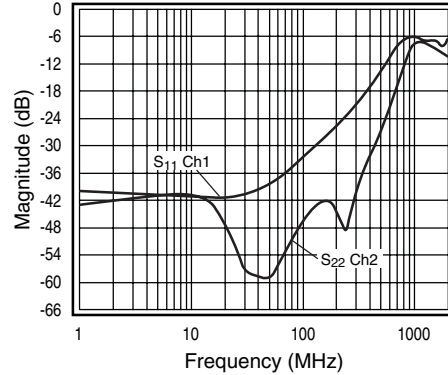

**Reverse Isolation ( $S_{12}$ )**

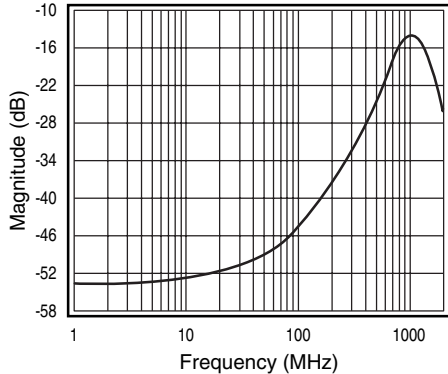

**Linear Phase Deviation**

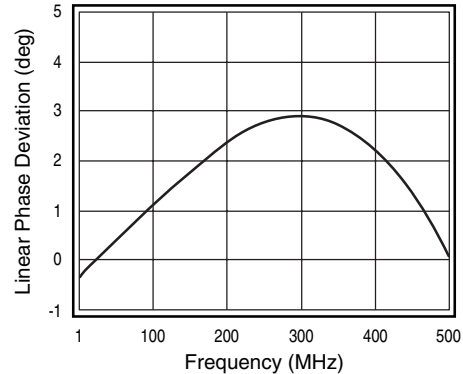

**Input Noise**

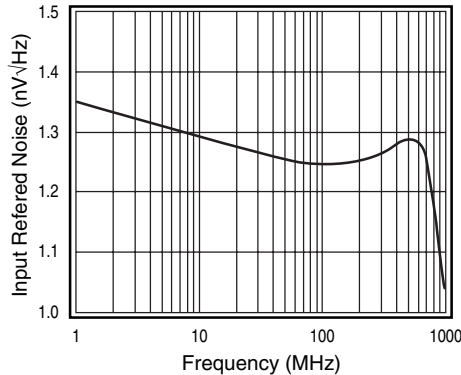

**Differential Gain vs. Supply Voltage**

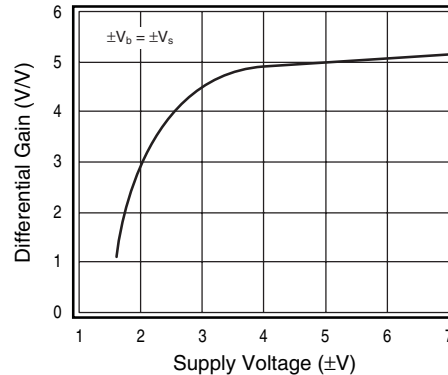

**2 Tone 3rd Order Intermod. Distortion**

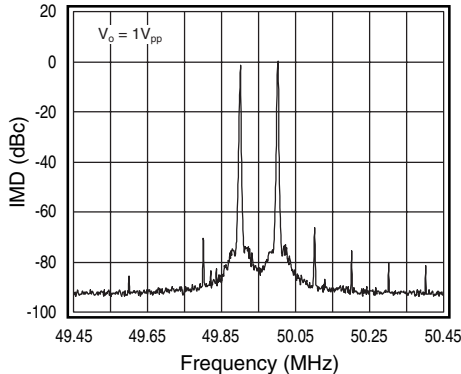

**2 Tone 3rd Order Intermod. Distortion**

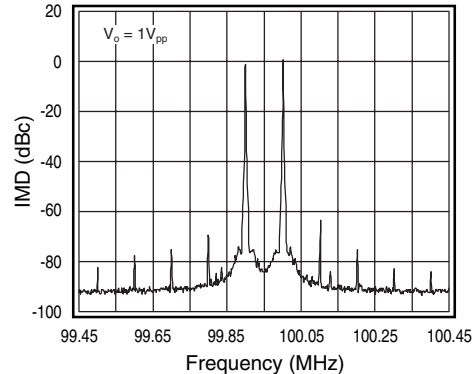

# KH600 Performance Characteristics

( $G = +5V/V$  (14dB),  $R_L = 100\Omega$  (differential),  $T_a = +25^\circ C$ ,  $+V_{b1} = +V_{b2} = +V_s = +5V$ ,  $-V_b = -V_s = -5V$ ; unless noted)

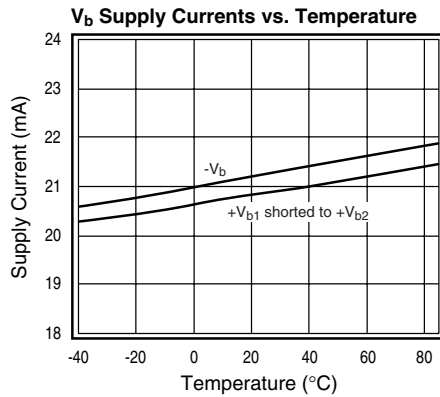
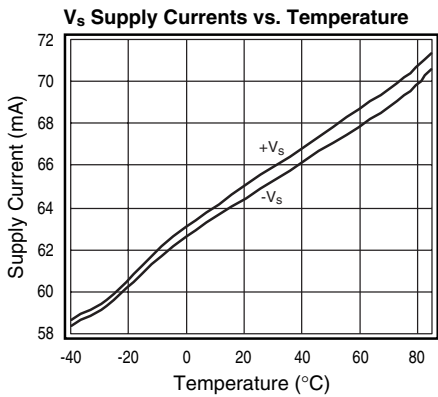
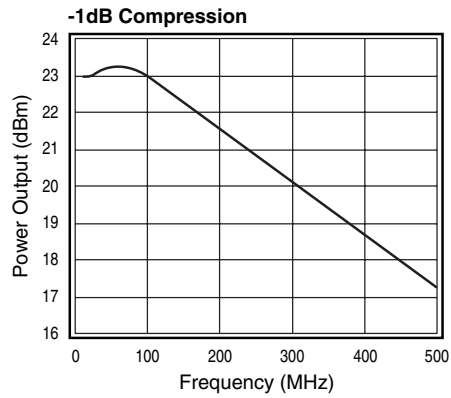
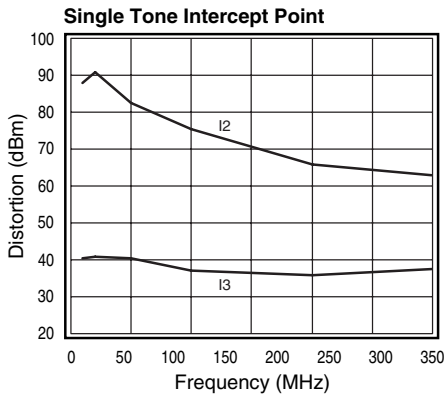
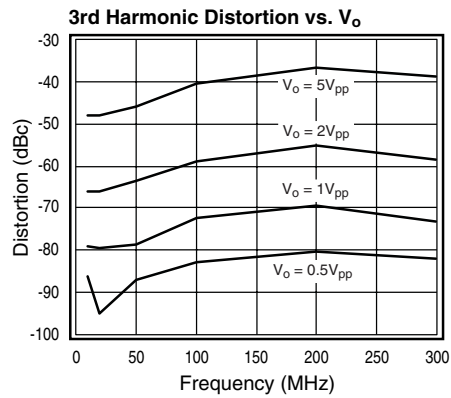
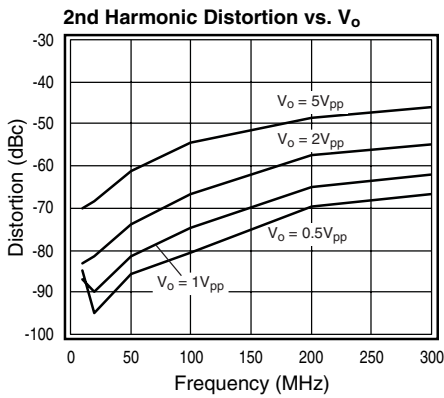
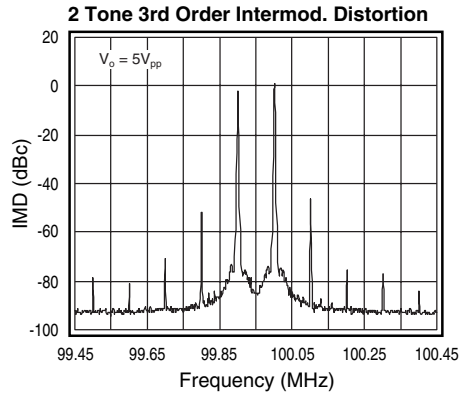
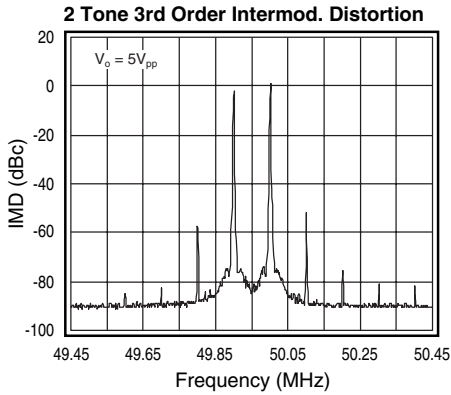

# KH600 Performance Characteristics

(G = +5V/V (14dB),  $R_L = 100\Omega$  (differential),  $T_a = +25^\circ\text{C}$ ,  $+V_{b1} = +V_{b2} = +V_s = +5\text{V}$ ,  $-V_b = -V_s = -5\text{V}$ ; unless noted)

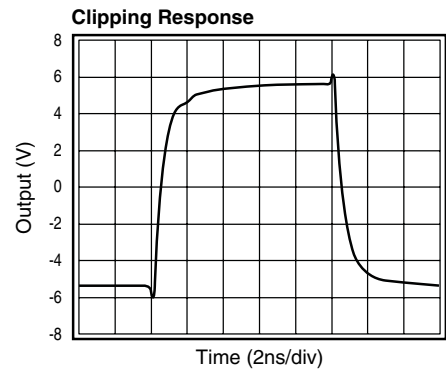
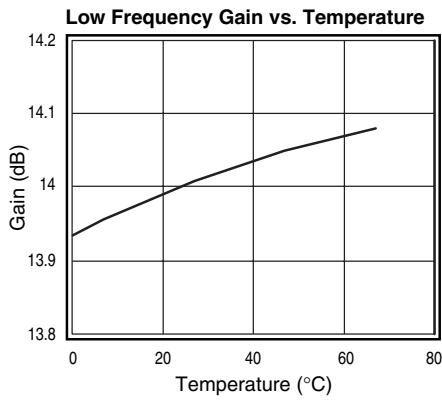
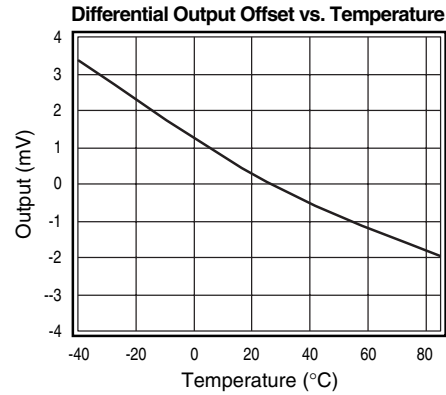
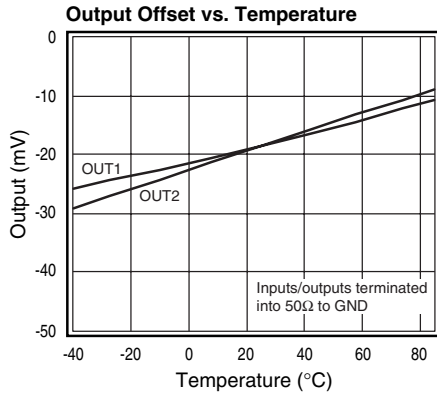

Pin Description

Pin #'s	Name	Function
6, 10	+V <sub>s</sub>	Positive supply voltage
8	-V <sub>s</sub>	Negative supply voltage
11	+V <sub>b1</sub>	Positive bias voltage for OUT1
5	+V <sub>b2</sub>	Positive bias voltage for OUT2
2	-V <sub>b</sub>	Negative bias voltage for OUT1 and OUT2
1	IN1	Input 1, +IN
3	IN2	Input 2, -IN
9	OUT1	Output 1, +OUT
7	OUT2	Output 2, -OUT
4, 12	GND	Input termination ground and case

General Description

Standard Operation:

$$+V_{b1} = +V_{b2} = +V_s = +5V;$$

$$-V_b = -V_s = -5V$$

The KH600 is a 1GHz differential input/output amplifier constructed using Fairchild's in-house thin film resistor/bipolar transistor technology. A differential signal on the inputs of the KH600 will generate a differential signal at the outputs. If a single ended input signal is applied to IN1 and a fixed voltage to IN2, the KH600 will produce both a differential and common-mode output signal. To achieve the maximum dynamic range, center the inputs halfway between +V<sub>s</sub> and -V<sub>s</sub>.

The KH600 includes 50Ω resistors from each input to ground, resulting in a differential input impedance of 100Ω. Each KH600 output has a 50Ω resistance, synthesized by feedback, providing a 100Ω differential output impedance.

The KH600 has 3 bias voltage pins that can be used to:

- Adjust the supply current
- Trim the differential output offset voltage
- Adjust the common mode output offset voltage over a ±3V range

If these adjustments are not required, short +V<sub>b1</sub> and +V<sub>b2</sub> to +V<sub>s</sub> and -V<sub>b</sub> to -V<sub>s</sub> as shown in Figure 1. Throughout this data sheet, this configuration (+V<sub>b1</sub> = +V<sub>b2</sub> = +V<sub>s</sub> = +5V and -V<sub>b</sub> = -V<sub>s</sub> = -5V) is referred to as the Standard Operating Condition. All of the plots in the *Typical Performance* section and the specifications in the *Electrical Characteristics* table utilize the basic circuit configuration shown in Figure 1, unless otherwise indicated.

Figure 2 illustrates the optional circuit configuration, utilizing the bias voltage pins. Further discussions regarding these optional adjustments are provided later in this document.

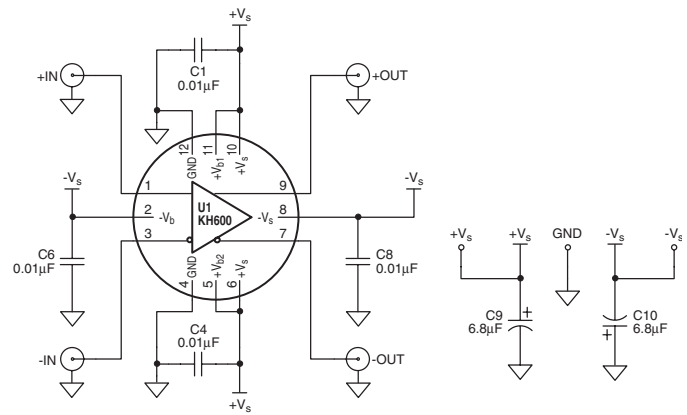

Figure 1: Basic Circuit Configuration

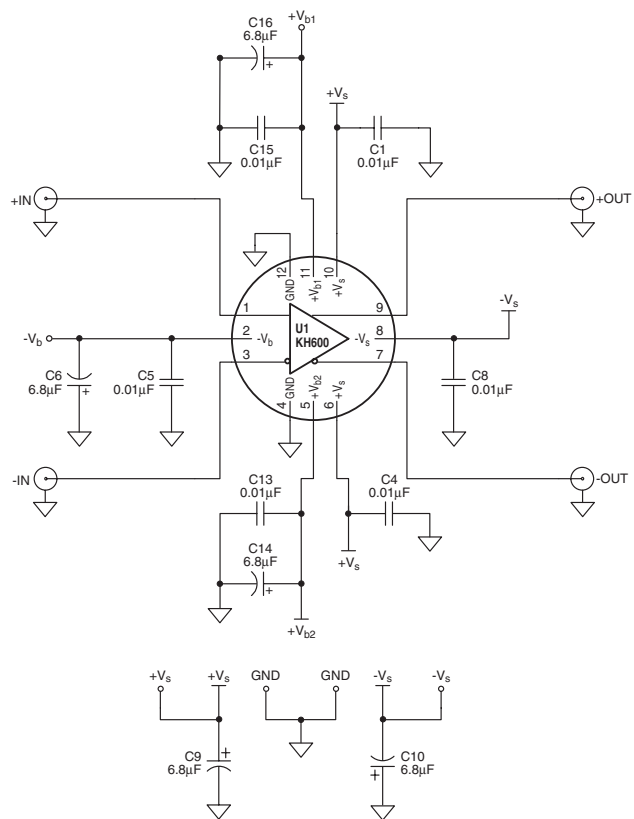

Figure 2: Optional Circuit Configuration (including optional supply current and offset adjust)

Gain

Differential Gain for the KH600 is defined as (OUT1-OUT2)/(IN1-IN2). Applying identical (same phase) signals to both inputs and measuring one output will provide the Common Mode Gain. Figure 3 shows the differential and common mode gains of the KH600. Figure 4 illustrates the response of the KH600 outputs when one input is driven and the other is terminated into 50Ω.

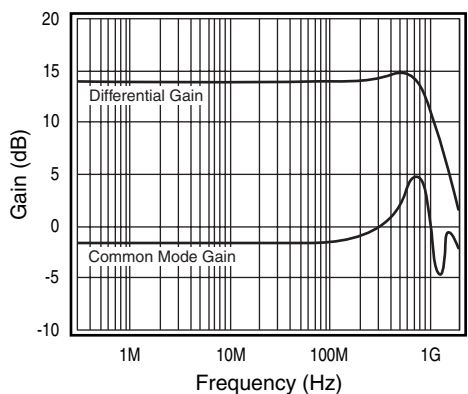

Figure 3: Differential and Common Mode Gain

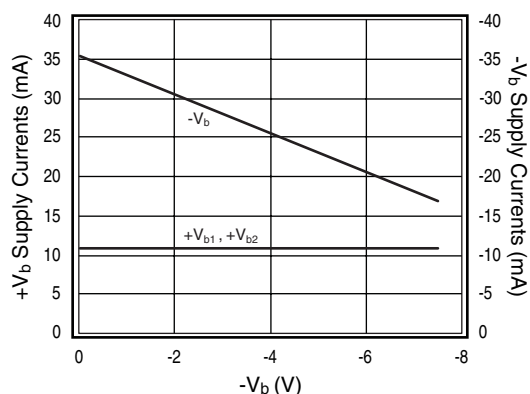

Figure 6:  $V_b$  Supply Currents vs  $-V_b$

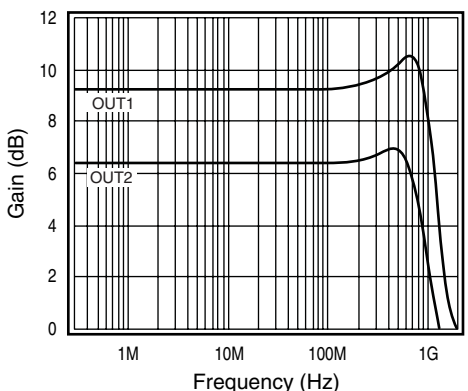

Figure 4: Gain with Single-Ended Input Applied to IN1

**Supply Current**

The KH600 draws supply current from the 2  $V_s$  pins as well as the 3  $V_b$  pins. Under Standard Conditions, the total supply current is typically 89mA. Changing the voltages on the bias voltage pins will change their respective supply currents as shown in Figures 5 and 6.

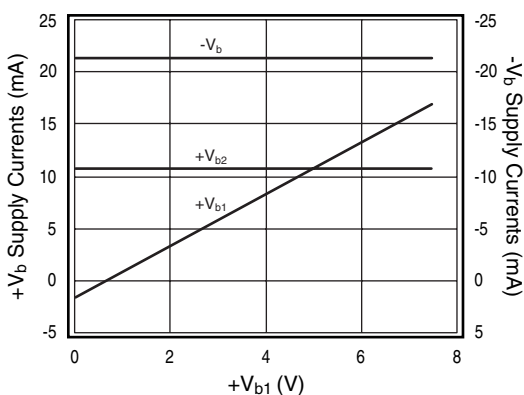

Figure 5:  $V_b$  Supply Currents vs  $+V_{b1}$

Changing the voltage on the  $+V_{b1}$  pin will alter the supply current for  $+V_{b1}$  only,  $+V_{b2}$  and  $-V_b$  stay constant at typically 11mA and 22mA respectively. See Figure 5. The same principle applies for  $+V_{b2}$ . And Figure 6 illustrates the effect of changing  $-V_b$ .

**Power Dissipation**

The KH600 runs at “constant” power, which may be calculated by  $(Total I_s)(V_s - (-V_s))$ . Under standard operating conditions, the power is 890mW. The power dissipated in the package is completely constant, independent of signal level. In other words, the KH600 runs class A.

**Power Supply Rejection Ratio (PSRR)**

The KH600 has 5 supply pins,  $+V_s$ ,  $-V_s$ ,  $+V_{b1}$ ,  $+V_{b2}$ , and  $-V_b$ . All of these sources must be considered when measuring the PSRR. Figure 7 shows the response of  $+V_s$  and  $-V_s$ , looking at OUT2.  $+V_s$  and  $-V_s$  have the same effect on OUT1.

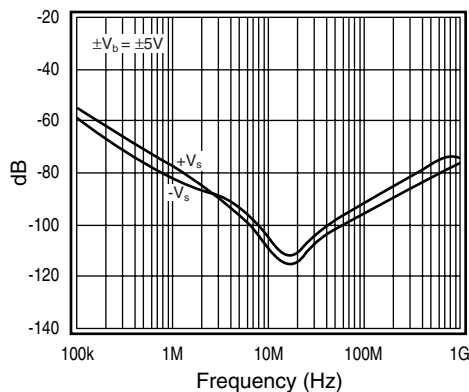

Figure 7:  $\pm V_s$  PSRR

Figure 8 shows the response of OUT1 and OUT2 when  $+V_{b1}$  changes. The PSRR of the  $V_b$  pins is “bad”, which means that they have a large effect on the response of the KH600 when their voltages are changed. This is the desired effect of the bias voltage pins. As Figure 8 indicates, changing  $+V_{b1}$  has a greater effect on OUT1 than it does on OUT2. Changing  $+V_{b1}$  has a direct effect on OUT1. Changing  $+V_{b2}$  has a direct effect on OUT2. See the *Trimming Differential Output Offset Voltage* section for more details.

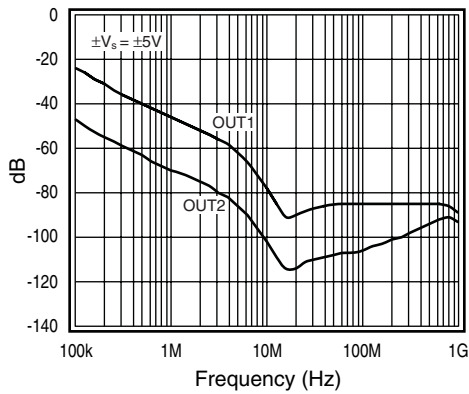

Figure 8: +V<sub>b</sub> PSRR

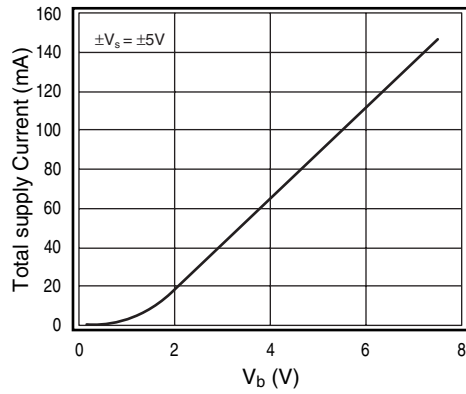

Figure 9: Total Supply Current vs. V<sub>b</sub>

**Single-to-Differential Operation**

The KH600 is specifically designed for differential-to-differential operation. However, the KH600 can be used in a single-to-differential configuration with some performance degradation. The unused input should be terminated into 50Ω. When driven single-ended, there will be a slight imbalance in the differential output voltages, see Figure 4. This imbalance is approximately 2.88dB. To compensate for this imbalance, attenuate the higher gain output. (If the signal is applied to IN1, attenuate OUT1.)

**Unused Inputs and/or Outputs**

For optimal performance, terminate any unused inputs and/or outputs with 50Ω.

**Adjusting Supply Current**

The KH600 operates class A, so maximum output current is directly proportional to supply current. Adjusting the voltages on +V<sub>b1</sub> and +V<sub>b2</sub> in opposition to -V<sub>b</sub> controls supply current. The default supply current of the KH600 has been optimized for best bandwidth and distortion performance. The main reason for adjusting supply current is to either reduce power or increase maximum output current. Adjusting the supply current will not significantly improve bandwidth or distortion and may actually degrade them.

To adjust the supply current, apply voltages of equal magnitude, but opposite polarity, to the bias voltage pins. For example, setting +V<sub>b1</sub>, +V<sub>b2</sub> to +5VDC and -V<sub>b</sub> to -5VDC (as shown in Figure 2) results in the standard supply current condition. Setting +V<sub>b1</sub>, +V<sub>b2</sub> to +5.5V and -V<sub>b</sub> to -5.5V results in an approximate 10% increase in supply current. Figure 9 shows the how the total supply current of the KH600 is effected by changes in the bias voltages (V<sub>b</sub> = +V<sub>b1</sub> = +V<sub>b2</sub> = |-V<sub>b</sub>|).

Supply current is relatively independent of the voltages on +V<sub>s</sub> and -V<sub>s</sub> as shown in Figure 10.

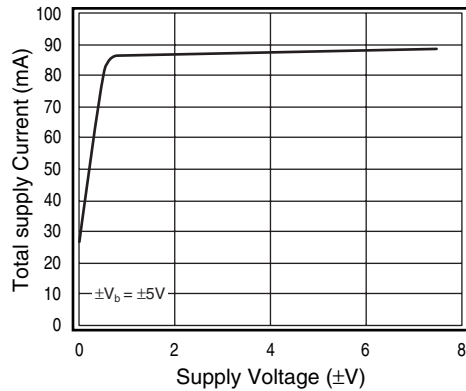

Figure 10: Total Supply Current vs. V<sub>s</sub>

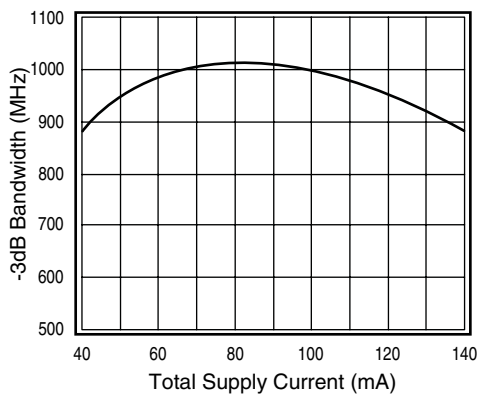

Figure 11: -3dB Bandwidth vs. I<sub>s</sub>



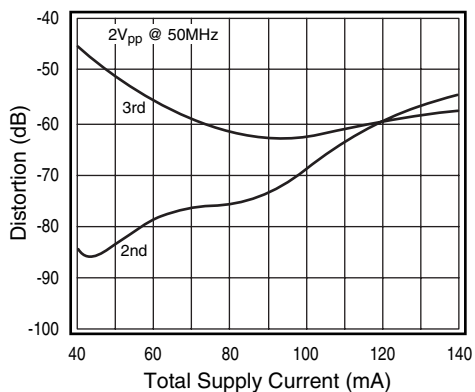

Figure 12: Harmonic Distortion vs. Total  $I_s$

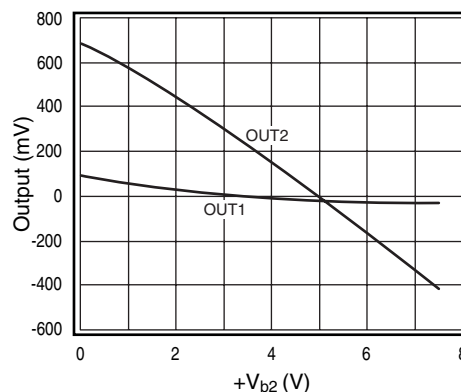

Figure 15: Output vs.  $+V_{b2}$

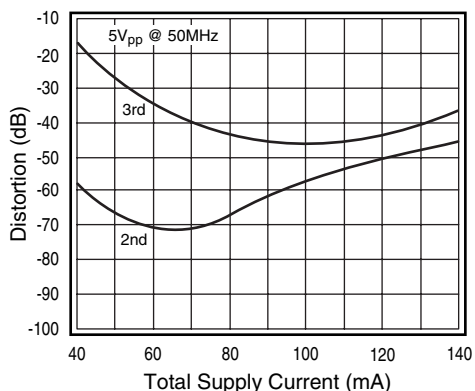

Figure 13: Harmonic Distortion vs. Total  $I_s$

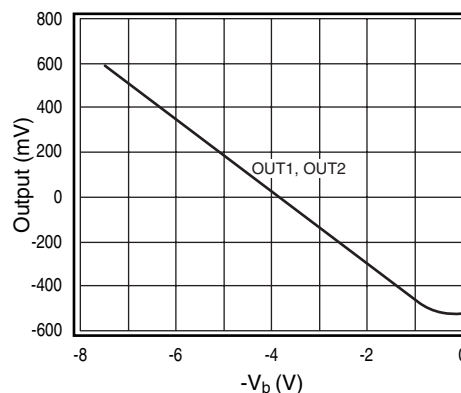

Figure 16: Output vs.  $-V_b$

**Trimming Differential Output Offset Voltage**

Vary  $+V_{b1}$  and  $+V_{b2}$  to adjust differential output offset voltage.  $+V_{b1}$  controls OUT1 and  $+V_{b2}$  controls OUT2. The output voltage moves in a direction opposite to the direction of the bias voltage. Figure 14 shows the resulting voltage change at OUT1 and OUT2 when the voltage on  $+V_{b1}$  is changed. Figure 15 shows the resulting voltage change at OUT1 and OUT2 when the voltage on  $+V_{b2}$  is changed. OUT1 and OUT2 change at the same rate when  $-V_b$  is changed, as shown in Figure 16. Therefore, changing the voltage on  $-V_b$  has no effect on differential output offset voltage.

**Adjusting Common Mode Output Offset Voltage**

Short  $+V_{b1}$  to  $+V_{b2}$  and vary  $+V_b$  and  $-V_b$  to adjust common mode output offset voltage. The recommended values for achieving a given output offset are shown in Figure 17. These values were chosen to give the best distortion performance. The exact values are not crucial.

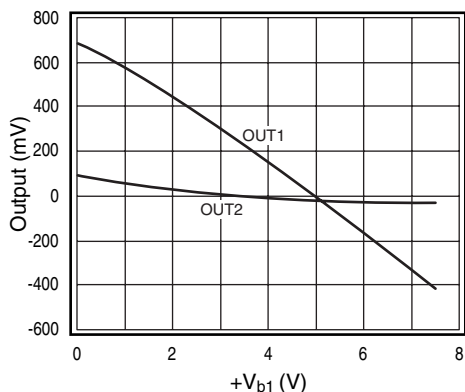

Figure 14: Output vs.  $+V_{b1}$

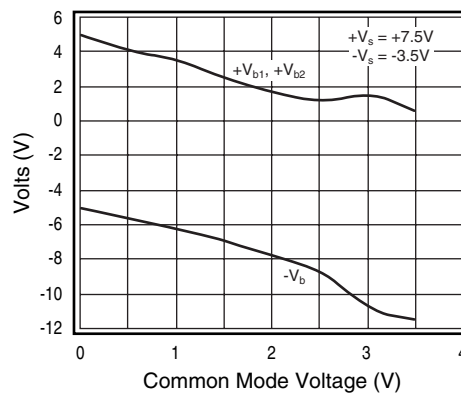

Figure 17:  $V_b$  vs. Common Mode Voltage

For common mode voltages of 0 to -3.5V swap the  $V_b$ 's and change the polarity. See the example below.

Desired Common Mode Voltage	$+V_{b1}$ and $+V_{b2}$ (V)	$-V_b$ (V)
2 Volts	2	-8
-2 Volts	8	-2

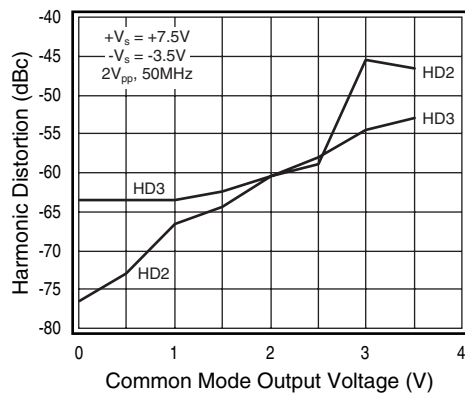

Figure 18: 2V<sub>pp</sub> HD vs. Common Mode Voltage

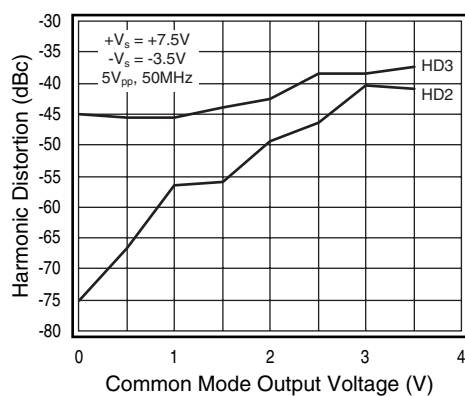

Figure 19: 5V<sub>pp</sub> HD vs. Common Mode Voltage

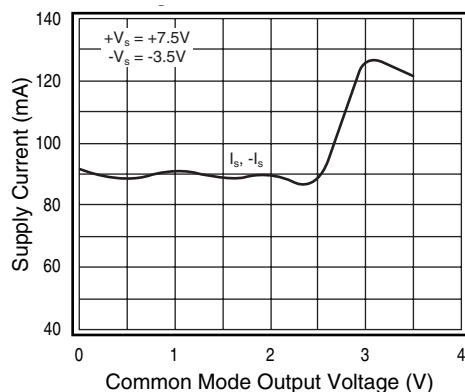

Figure 20: Resulting  $I_s$  and  $-I_s$

Figures 18 and 19 illustrate how the common mode voltage effects harmonic distortion. Figure 20 show the resulting  $I_s$  and  $-I_s$  supply currents.

Pay close attention to your peak-to-peak output voltage requirement. As you change the common mode voltage, you may need to increase or shift  $\pm V_s$  in order to achieve your output requirements. A 2V margin is recommended. For example, if your output requirement is 5V<sub>pp</sub> and you will be changing the common mode from 1V to 3V set  $V_s = +7.5$  and  $-V_s$  to -3.5V. This example calls for a supply voltage of greater than 10V. This will not effect supply current because as Figure 10 indicates, changing  $\pm V_s$  has no effect on supply current.

**Layout Considerations**

General layout and supply bypassing play major roles in high frequency performance. Fairchild has evaluation boards to use as a guide for high frequency layout and as aid in device testing and characterization. Follow the steps below as a basis for high frequency layout:

- Include all recommended 6.8 $\mu$ F and 0.01 $\mu$ F bypass capacitors
- Place the 6.8 $\mu$ F capacitors within 0.75 inches of the power pin
- Place the 0.01 $\mu$ F capacitors within 0.1 inches of the power pin
- Remove the ground plane under and around the part, especially near the input and output pins to reduce parasitic capacitance
- Minimize all trace lengths to reduce series inductances
- A 10pF to 50pF bypass capacitor can be used between pins 5 and 6 and between pins 10 and 11 to reduce crosstalk from the positive supply

Refer to the evaluation board layouts shown in Figure 21 for more information.

**Evaluation Board Information**

The following evaluation boards are available to aid in the testing and layout of this device:

Evaluation Board	Description	Products
KEB007	Basic KH600 Eval Bd	KH600
KEB009	KH600 Eval Bd with offset and $I_{cc}$ Adjust Option	KH600

Do not include capacitors C2, C3, C7, C11, and C12 that are shown on the KEB007 evaluation board. Evaluation board schematics and layouts are shown in Figure 21. Refer to the schematic shown in Figure 1 for the KEB007 board and Figure 2 for the KEB009 board.

# KH600 Evaluation Board Layout

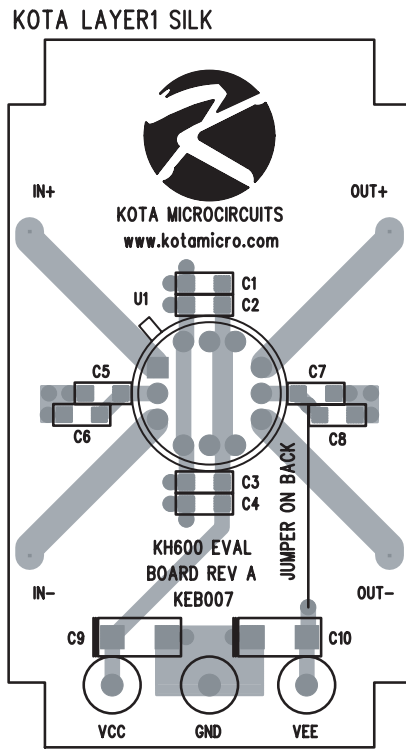

Figure 21a: KEB007 (top side)

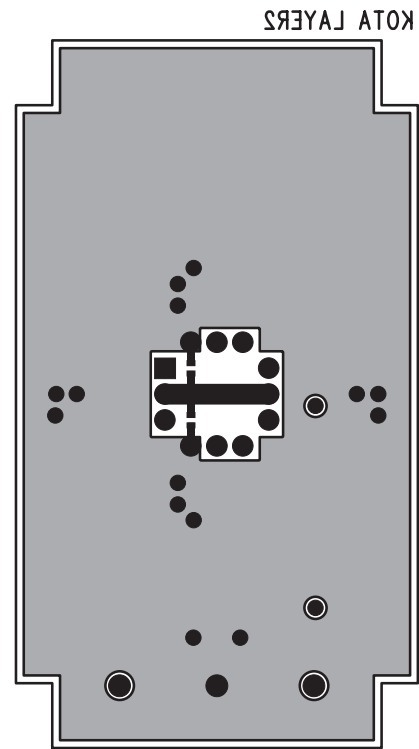

Figure 21b: KEB007 (bottom side)

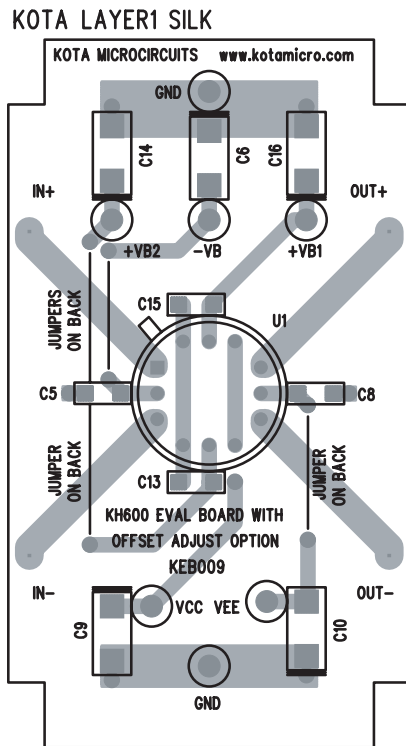

Figure 21c: KEB009 (top side)

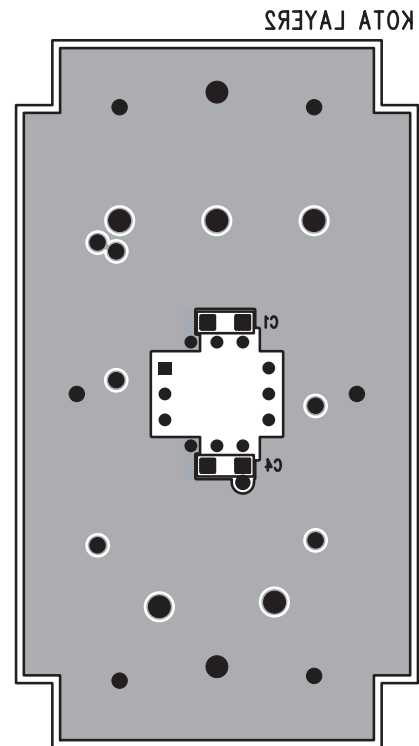
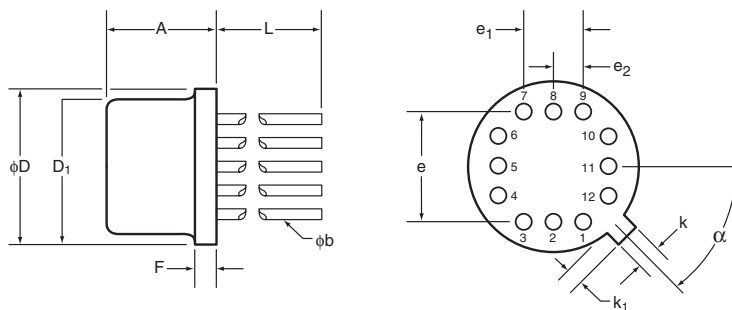

Figure 21d: KEB009 (bottom side)

### KH600 Package Dimensions



TO-8				
SYMBOL	INCHES		MILIMETERS	
	Minimum	Maximum	Minimum	Maximum
A	0.142	0.181	3.61	4.60
$\phi b$	0.016	0.019	0.41	0.48
$\phi D$	0.595	0.605	15.11	15.37
$\phi D_1$	0.543	0.555	13.79	14.10
e	0.400 BSC		10.16 BSC	
e <sub>1</sub>	0.200 BSC		5.08 BSC	
e <sub>2</sub>	0.100 BSC		2.54 BSC	
F	0.016	0.030	0.41	0.76
k	0.026	0.036	0.66	0.91
k <sub>1</sub>	0.026	0.036	0.66	0.91
L	0.310	0.340	7.87	8.64
$\alpha$	45° BSC		45° BSC	

**NOTES:**

- Seal: cap weld
- Lead finish: gold per MIL-M-38510
- Package composition:
  - Package: metal
  - Lid: Type A per MIL-M-38510

### Ordering Information

Part No.	Temperature	Package	Eval. Board
KH600AI	-40°C to +85°C	12-pin TO8	KEB007, KEB009

**DISCLAIMER**

FAIRCHILD SEMICONDUCTOR RESERVES THE RIGHT TO MAKE CHANGES WITHOUT FURTHER NOTICES TO ANY PRODUCTS HEREIN TO IMPROVE RELIABILITY, FUNCTION OR DESIGN. FAIRCHILD DOES NOT ASSUME ANY LIABILITY ARISING OUT OF THE APPLICATION OR USE OF ANY PRODUCT OR CIRCUIT DESCRIBED HEREIN; NEITHER DOES IT CONVEY ANY LICENSE UNDER ITS PATENT RIGHTS, NOR THE RIGHTS OF OTHERS.

**LIFE SUPPORT POLICY**

FAIRCHILD'S PRODUCTS ARE NOT AUTHORIZED FOR USE AS CRITICAL COMPONENTS IN LIFE SUPPORT DEVICES OR SYSTEMS WITHOUT THE EXPRESS WRITTEN APPROVAL OF THE PRESIDENT OF FAIRCHILD SEMICONDUCTOR CORPORATION. As used herein:

1. Life support devices or systems are devices or systems which, (a) are intended for surgical implant into the body, or (b) support or sustain life, and (c) whose failure to perform when properly used in accordance with instructions for use provided in the labeling, can be reasonably expected to result in a significant injury of the user.
2. A critical component in any component of a life support device or system whose failure to perform can be reasonably expected to cause the failure of the life support device or system, or to affect its safety or effectiveness.