

**128K x 8 HIGH-SPEED CMOS STATIC RAM**

MAY 2006

**FEATURES**

- High-speed access time:  
 12 ns: 3.3V ± 10%  
 15 ns: 2.5V – 3.6V
- High-performance, low-power CMOS process
- CMOS Low Power Operation  
 50 mW (typical) operating current  
 25 µW (typical) standby current
- Multiple center power and ground pins for greater noise immunity
- Easy memory expansion with  $\overline{CE}$  and  $\overline{OE}$  options
- $\overline{CE}$  power-down
- Fully static operation: no clock or refresh required
- TTL compatible inputs and outputs
- Packages available:
  - 32-pin TSOP (Type II)
  - 32-pin sTSOP (Type I)
  - 48-Ball miniBGA (6mm x 8mm)
  - 32-pin 300-mil SOJ
- Lead-free available

**DESCRIPTION**

The *ISSI* IS63/64WV1024BLL is a very high-speed, low power, 131,072-word by 8-bit CMOS static RAM. The IS63/64WV1024BLL is fabricated using *ISSI*'s high-performance CMOS technology. This highly reliable process coupled with innovative circuit design techniques, yields higher performance and low power consumption devices.

When  $\overline{CE}$  is HIGH (deselected), the device assumes a standby mode at which the power dissipation can be reduced down to 25 µW (typical) with CMOS input levels.

The IS63/64WV1024BLL operates from a single  $V_{DD}$  power supply. The IS63/64WV1024BLL is available in 32-pin TSOP (Type II), 32-pin sTSOP (Type I), 48-Ball miniBGA (6mm x 8mm), and 32-pin SOJ (300-mil) packages.

**FUNCTIONAL BLOCK DIAGRAM**

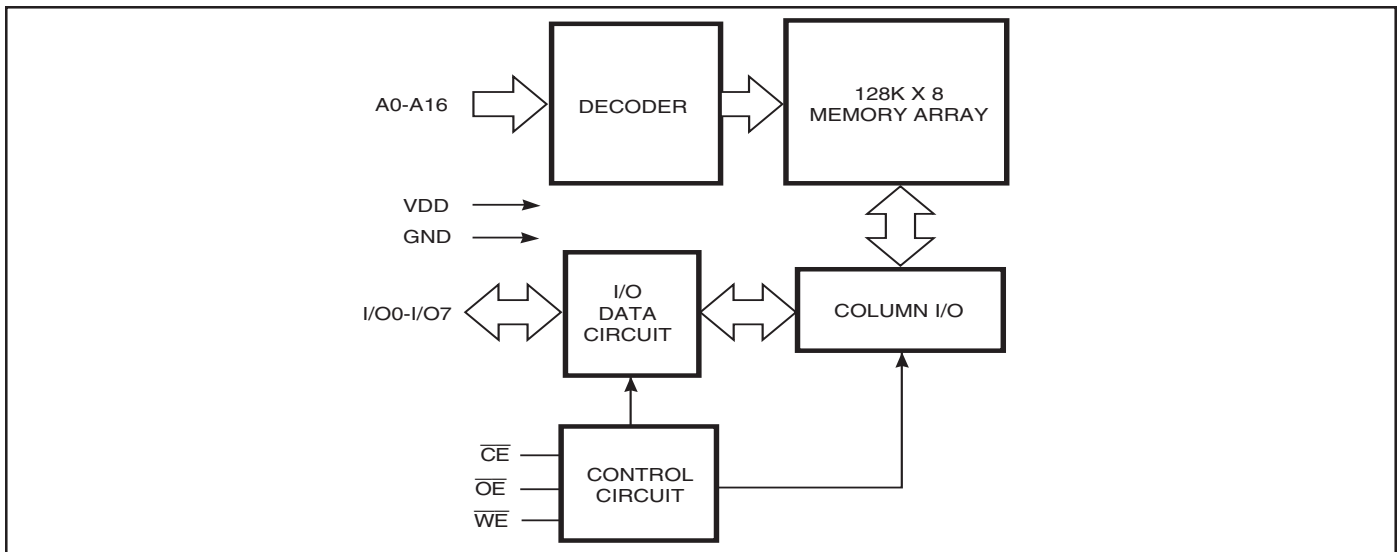

Copyright © 2006 Integrated Silicon Solution, Inc. All rights reserved. ISSI reserves the right to make changes to this specification and its products at any time without notice. ISSI assumes no liability arising out of the application or use of any information, products or services described herein. Customers are advised to obtain the latest version of this device specification before relying on any published information and before placing orders for products.

**PIN CONFIGURATION**  
32-Pin SOJ

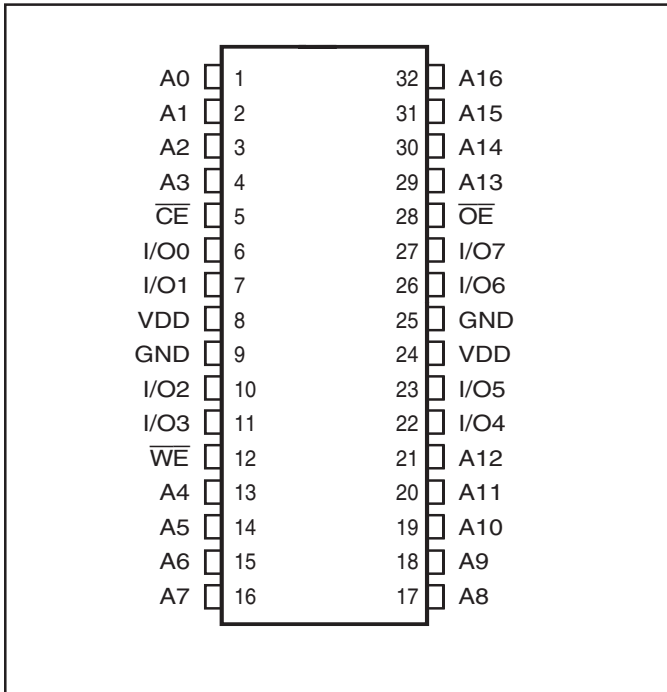

**PIN CONFIGURATION**  
32-Pin TSOP (Type II) (T)  
32-Pin sTSOP (Type I) (H)

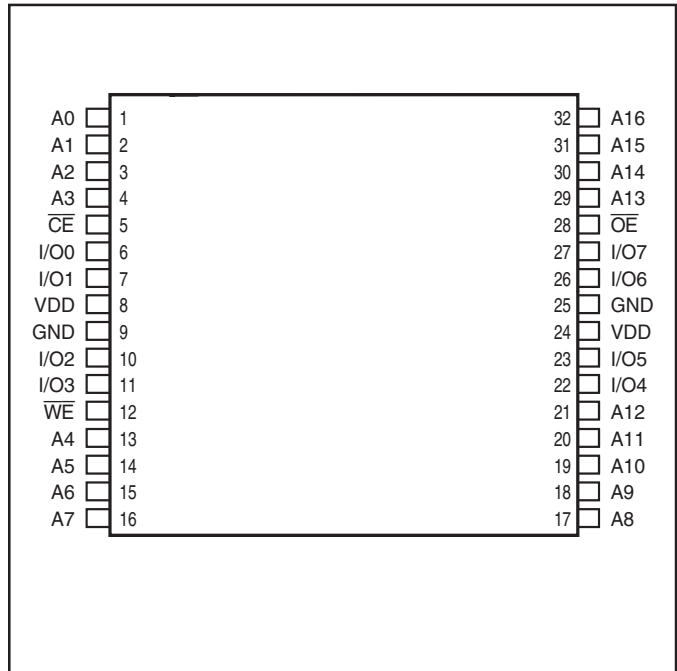

**PIN DESCRIPTIONS**

A0-A16	Address Inputs
$\overline{CE}$	Chip Enable Input
$\overline{OE}$	Output Enable Input
$\overline{WE}$	Write Enable Input
I/O0-I/O7	Bidirectional Ports
V <sub>DD</sub>	Power
GND	Ground

**PIN CONFIGURATION**  
48-mini BGA (B) (6 mm x 8 mm)

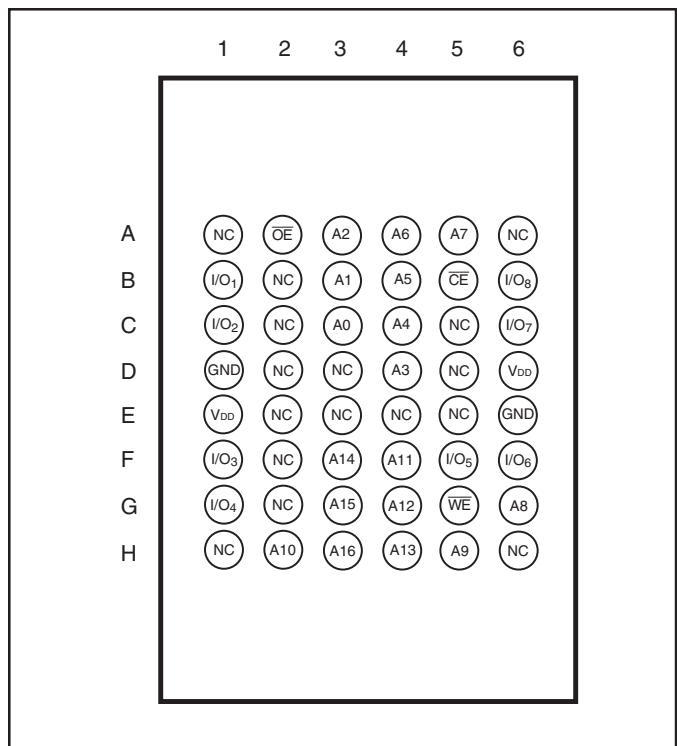

**TRUTH TABLE**

Mode	$\overline{WE}$	$\overline{CE}$	$\overline{OE}$	I/O Operation	V <sub>DD</sub> Current
Not Selected (Power-down)	X	H	X	High-Z	I <sub>SB1</sub> , I <sub>SB2</sub>
Output Disabled	H	L	H	High-Z	I <sub>CC1</sub> , I <sub>CC2</sub>
Read	H	L	L	D <sub>OUT</sub>	I <sub>CC1</sub> , I <sub>CC2</sub>
Write	L	L	X	D <sub>IN</sub>	I <sub>CC1</sub> , I <sub>CC2</sub>

**ABSOLUTE MAXIMUM RATINGS<sup>(1)</sup>**

Symbol	Parameter	Value	Unit
V <sub>TERM</sub>	Terminal Voltage with Respect to GND	-0.5 to V <sub>DD</sub> +0.5	V
T <sub>STG</sub>	Storage Temperature	-65 to +150	°C
P <sub>T</sub>	Power Dissipation	1.5	W
V <sub>DD</sub>	V <sub>DD</sub> Related to GND	-0.2 to +3.9	V

**Note:**

1. Stress greater than those listed under ABSOLUTE MAXIMUM RATINGS may cause permanent damage to the device. This is a stress rating only and functional operation of the device at these or any other conditions above those indicated in the operational sections of this specification is not implied. Exposure to absolute maximum rating conditions for extended periods may affect reliability.

**OPERATING RANGE (V<sub>DD</sub>)**

Range	Ambient Temperature	V <sub>DD</sub> (15 ns)	V <sub>DD</sub> (12 ns)
Commercial	0°C to +70°C	2.5V-3.6V	3.3V ± 10%
Industrial	-40°C to +85°C	2.5V-3.6V	3.3V ± 10%
Automotive	-40°C to +125°C	2.5V-3.6V	3.3V ± 10%

**DC ELECTRICAL CHARACTERISTICS** (Over Operating Range)

**V<sub>DD</sub> = 2.5V-3.6V**

Symbol	Parameter	Test Conditions	Min.	Max.	Unit
V <sub>OH</sub>	Output HIGH Voltage	V <sub>DD</sub> = Min., I <sub>OH</sub> = -1.0 mA	2.3	—	V
V <sub>OL</sub>	Output LOW Voltage	V <sub>DD</sub> = Min., I <sub>OL</sub> = 1.0 mA	—	0.4	V
V <sub>IH</sub>	Input HIGH Voltage		2.0	V <sub>DD</sub> + 0.3	V
V <sub>IL</sub>	Input LOW Voltage <sup>(1)</sup>		-0.3	0.8	V
I <sub>LI</sub>	Input Leakage	GND ≤ V <sub>IN</sub> ≤ V <sub>DD</sub>	-2	2	μA
I <sub>LO</sub>	Output Leakage	GND ≤ V <sub>OUT</sub> ≤ V <sub>DD</sub> , Outputs Disabled	-2	2	μA

**Note:**

- V<sub>IL</sub> (min.) = -0.3V DC; V<sub>IL</sub> (min.) = -2.0V AC (pulse width - 2.0 ns). Not 100% tested.  
V<sub>IH</sub> (max.) = V<sub>DD</sub> + 0.3V DC; V<sub>IH</sub> (max.) = V<sub>DD</sub> + 2.0V AC (pulse width - 2.0 ns). Not 100% tested.

**DC ELECTRICAL CHARACTERISTICS** (Over Operating Range)

**V<sub>DD</sub> = 3.3V ± 10%**

Symbol	Parameter	Test Conditions	Min.	Max.	Unit
V <sub>OH</sub>	Output HIGH Voltage	V <sub>DD</sub> = Min., I <sub>OH</sub> = -4.0 mA	2.4	—	V
V <sub>OL</sub>	Output LOW Voltage	V <sub>DD</sub> = Min., I <sub>OL</sub> = 8.0 mA	—	0.4	V
V <sub>IH</sub>	Input HIGH Voltage		2	V <sub>DD</sub> + 0.3	V
V <sub>IL</sub>	Input LOW Voltage <sup>(1)</sup>		-0.3	0.8	V
I <sub>LI</sub>	Input Leakage	GND ≤ V <sub>IN</sub> ≤ V <sub>DD</sub>	-2	2	μA
I <sub>LO</sub>	Output Leakage	GND ≤ V <sub>OUT</sub> ≤ V <sub>DD</sub> , Outputs Disabled	-2	2	μA

**Note:**

- V<sub>IL</sub> (min.) = -0.3V DC; V<sub>IL</sub> (min.) = -2.0V AC (pulse width - 2.0 ns). Not 100% tested.  
V<sub>IH</sub> (max.) = V<sub>DD</sub> + 0.3V DC; V<sub>IH</sub> (max.) = V<sub>DD</sub> + 2.0V AC (pulse width - 2.0 ns). Not 100% tested.

**POWER SUPPLY CHARACTERISTICS<sup>(1)</sup>** (Over Operating Range)

Symbol	Parameter	Test Conditions	Options	-12 ns		-15 ns		Unit
				Min.	Max.	Min.	Max.	
I <sub>CC</sub>	V <sub>DD</sub> Dynamic Operating Supply Current	V <sub>DD</sub> = Max., I <sub>OUT</sub> = 0 mA, f = f <sub>MAX</sub>	COM.	—	35	—	30	mA
			IND.	—	45	—	40	
			AUTO	—	60	—	50	
			typ. <sup>(2)</sup>	—	20	—	20	
I <sub>CC1</sub>	Operating Supply Current	V <sub>DD</sub> = Max., I <sub>OUT</sub> = 0mA, f = 0	COM.	—	5	—	5	mA
			IND.	—	5	—	5	
			AUTO	—	5	—	5	
I <sub>SB1</sub>	TTL Standby Current (TTL Inputs)	V <sub>DD</sub> = Max., V <sub>IN</sub> = V <sub>IH</sub> or V <sub>IL</sub> $\overline{CE} \geq V_{IH}$ , f = 0	COM.	—	3	—	3	mA
			IND.	—	4	—	4	
			AUTO	—	4	—	4	
I <sub>SB2</sub>	CMOS Standby Current (CMOS Inputs)	V <sub>DD</sub> = Max., $\overline{CE} \geq V_{DD} - 0.2V$ , V <sub>IN</sub> ≥ V <sub>DD</sub> - 0.2V, or V <sub>IN</sub> ≤ 0.2V, f = 0	COM.	—	20	—	20	uA
			IND.	—	50	—	50	
			AUTO	—	75	—	75	
			typ. <sup>(2)</sup>	—	6	—	6	

**Note:**

- At f = f<sub>MAX</sub>, address and data inputs are cycling at the maximum frequency, f = 0 means no input lines change.
- Typical values are measured at V<sub>DD</sub>=2.5V, T<sub>A</sub>=25°C. Not 100% tested.

**CAPACITANCE<sup>(1)</sup>**

Symbol	Parameter	Conditions	Max.	Unit
C <sub>IN</sub>	Input Capacitance	V <sub>IN</sub> = 0V	6	pF
C <sub>OUT</sub>	Input/Output Capacitance	V <sub>OUT</sub> = 0V	8	pF

**Note:**

- Tested initially and after any design or process changes that may affect these parameters.

AC TEST CONDITIONS

Parameter	Unit (2.5V-3.6V)	Unit (3.3V ± 10%)
Input Pulse Level	0V to V <sub>DD</sub> V	0V to V <sub>DD</sub> V
Input Rise and Fall Times	1.5ns	1.5ns
Input and Output Timing and Reference Level (V <sub>Ref</sub> )	V <sub>DD</sub> /2	V <sub>DD</sub> /2 + 0.05
Output Load	See Figures 1a and 1b	See Figures 1a and 1b

AC TEST LOADS

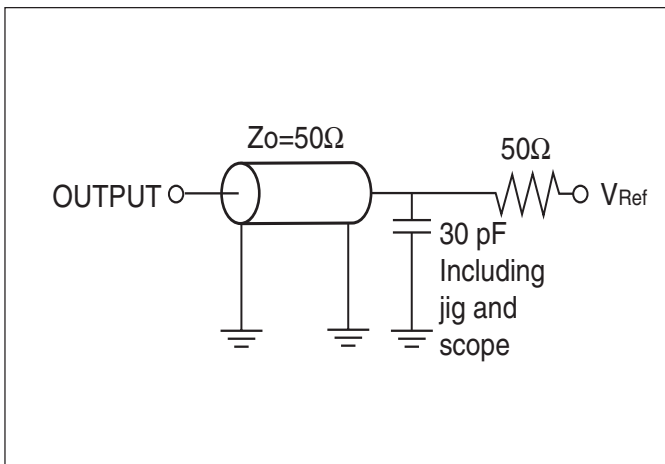

Figure 1a.

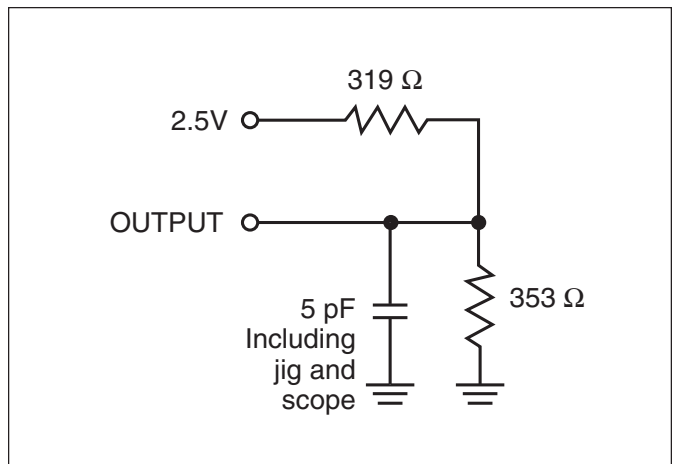

Figure 1b.

**READ CYCLE SWITCHING CHARACTERISTICS<sup>(1)</sup>** (Over Operating Range)

Symbol	Parameter	-12 ns		-15 ns		Unit
		Min.	Max.	Min.	Max.	
t <sub>RC</sub>	Read Cycle Time	12	—	15	—	ns
t <sub>AA</sub>	Address Access Time	—	12	—	15	ns
t <sub>OHA</sub>	Output Hold Time	3	—	3	—	ns
t <sub>ACE</sub>	$\overline{\text{CE}}$ Access Time	—	12	—	15	ns
t <sub>DOE</sub>	$\overline{\text{OE}}$ Access Time	—	6	—	7	ns
t <sub>LZOE<sup>(2)</sup></sub>	$\overline{\text{OE}}$ to Low-Z Output	0	—	0	—	ns
t <sub>HZOE<sup>(2)</sup></sub>	$\overline{\text{OE}}$ to High-Z Output	0	6	0	6	ns
t <sub>LZCE<sup>(2)</sup></sub>	$\overline{\text{CE}}$ to Low-Z Output	3	—	3	—	ns
t <sub>HZCE<sup>(2)</sup></sub>	$\overline{\text{CE}}$ to High-Z Output	0	6	0	6	ns
t <sub>PU</sub>	$\overline{\text{CE}}$ to Power Up Time	0	—	0	—	ns
t <sub>PD</sub>	$\overline{\text{CE}}$ to Power Down Time	—	12	—	15	ns

**Notes:**

1. Test conditions assume signal transition times of 3 ns or less, timing reference levels of 1.25V, input pulse levels of 0.4V to V<sub>DD</sub>-0.3V and output loading specified in Figure 1.
2. Tested with the loading specified in Figure 1. Transition is measured ±500 mV from steady-state voltage. Not 100% tested.

AC WAVEFORMS

READ CYCLE NO. 1<sup>(1,2)</sup>

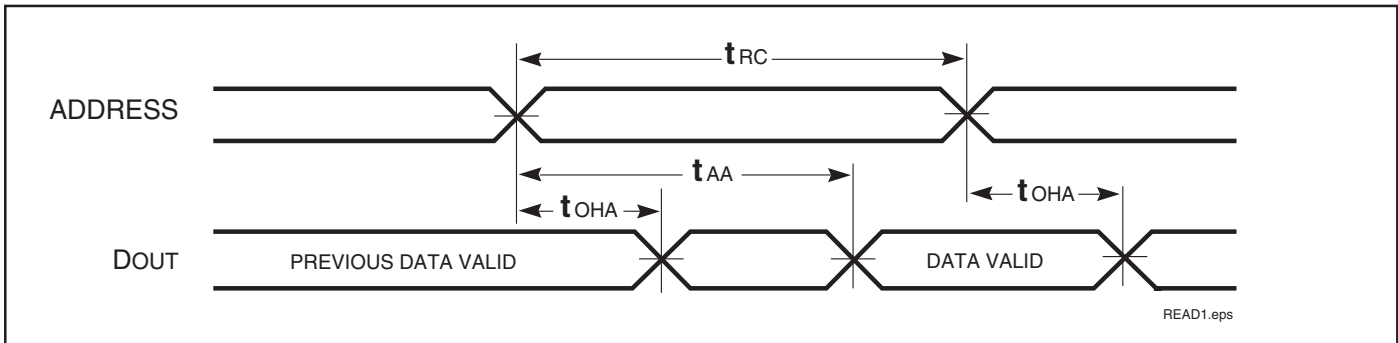

READ CYCLE NO. 2<sup>(1,3)</sup>

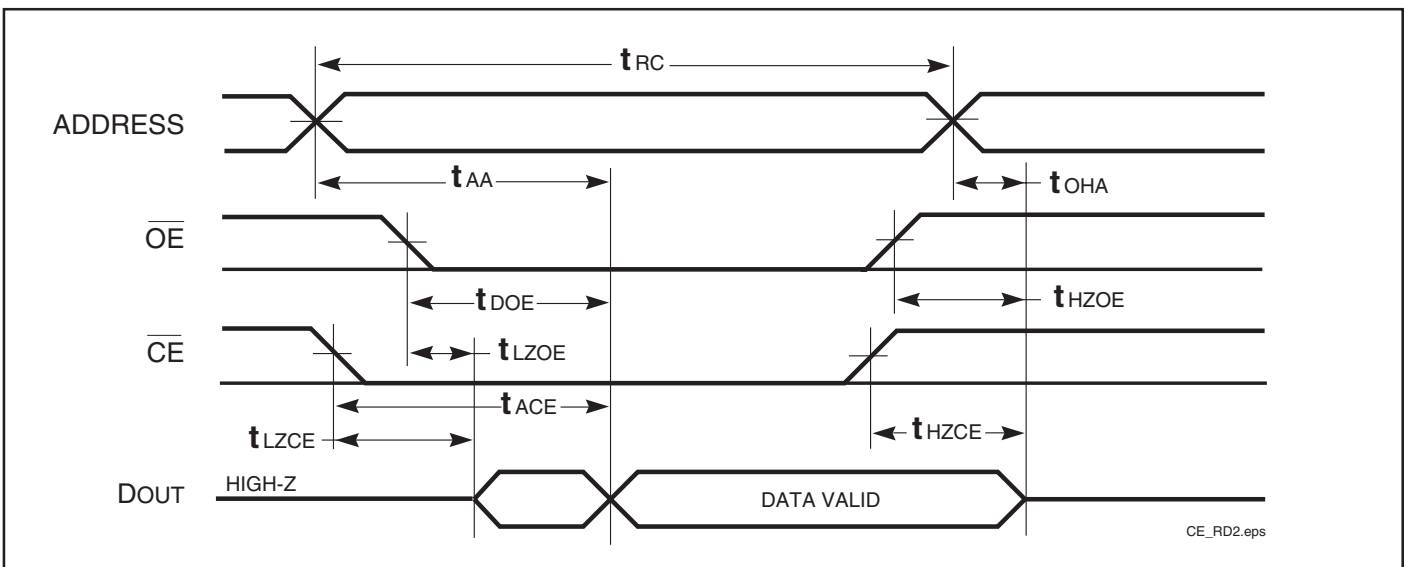

Notes:

1.  $\overline{WE}$  is HIGH for a Read Cycle.
2. The device is continuously selected.  $\overline{OE}$ ,  $\overline{CE} = V_{IL}$ .
3. Address is valid prior to or coincident with  $\overline{CE}$  LOW transitions.



**WRITE CYCLE SWITCHING CHARACTERISTICS<sup>(1,3)</sup>** (Over Operating Range)

Symbol	Parameter	-12 ns		-15 ns		Unit
		Min.	Max.	Min.	Max.	
t <sub>WC</sub>	Write Cycle Time	12	—	15	—	ns
t <sub>SCE</sub>	$\overline{CE}$ to Write End	9	—	10	—	ns
t <sub>AW</sub>	Address Setup Time to Write End	9	—	10	—	ns
t <sub>HA</sub>	Address Hold from Write End	0	—	0	—	ns
t <sub>SA</sub>	Address Setup Time	0	—	0	—	ns
t <sub>PWE1</sub> <sup>(1)</sup>	$\overline{WE}$ Pulse Width ( $\overline{OE}$ High)	9	—	10	—	ns
t <sub>PWE2</sub> <sup>(2)</sup>	$\overline{WE}$ Pulse Width ( $\overline{OE}$ Low)	11	—	12	—	ns
t <sub>SD</sub>	Data Setup to Write End	9	—	9	—	ns
t <sub>HD</sub>	Data Hold from Write End	0	—	0	—	ns
t <sub>HZWE</sub> <sup>(2)</sup>	$\overline{WE}$ LOW to High-Z Output	—	6	—	7	ns
t <sub>LZWE</sub> <sup>(2)</sup>	$\overline{WE}$ HIGH to Low-Z Output	3	—	3	—	ns

**Notes:**

1. Test conditions assume signal transition times of 3ns or less, timing reference levels of 1.25V, input pulse levels of 0.4V to V<sub>DD</sub>-0.3V and output loading specified in Figure 1a.
2. Tested with the loading specified in Figure 1b. Transition is measured ±500 mV from steady-state voltage. Not 100% tested.
3. The internal write time is defined by the overlap of  $\overline{CE}$  LOW and  $\overline{WE}$  LOW. All signals must be in valid states to initiate a Write, but any one can go inactive to terminate the Write. The Data Input Setup and Hold timing are referenced to the rising or falling edge of the signal that terminates the Write.

**AC WAVEFORMS**

**WRITE CYCLE NO. 1<sup>(1,2)</sup>** ( $\overline{CE}$  Controlled,  $\overline{OE}$  = HIGH or LOW)

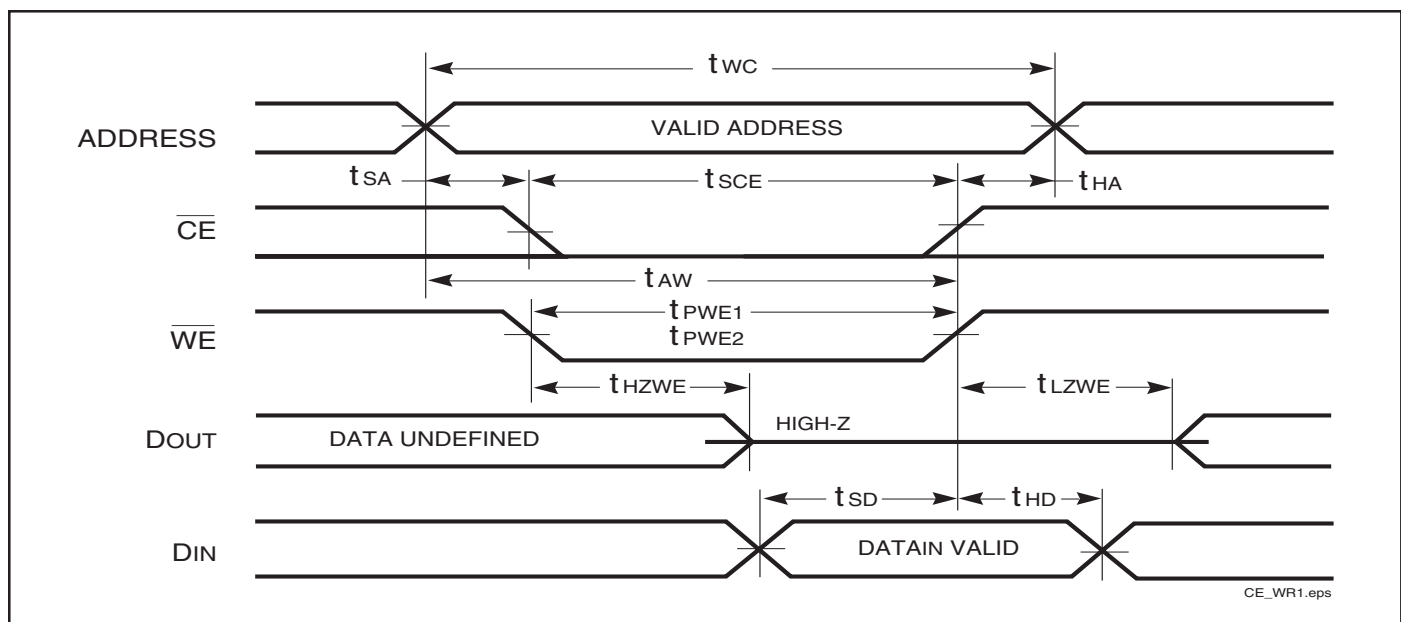

AC WAVEFORMS

WRITE CYCLE NO. 2<sup>(1)</sup> ( $\overline{WE}$  Controlled,  $\overline{OE}$  = HIGH during Write Cycle)

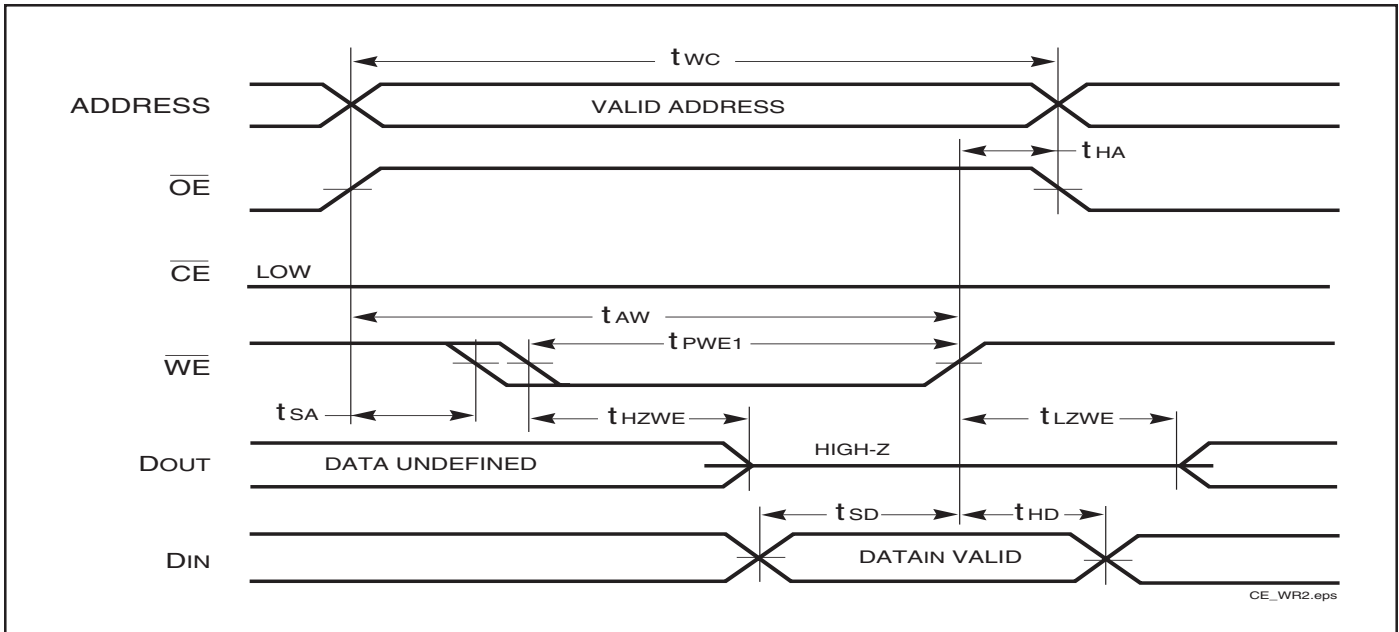

WRITE CYCLE NO. 3 ( $\overline{WE}$  Controlled:  $\overline{OE}$  is LOW During Write Cycle)

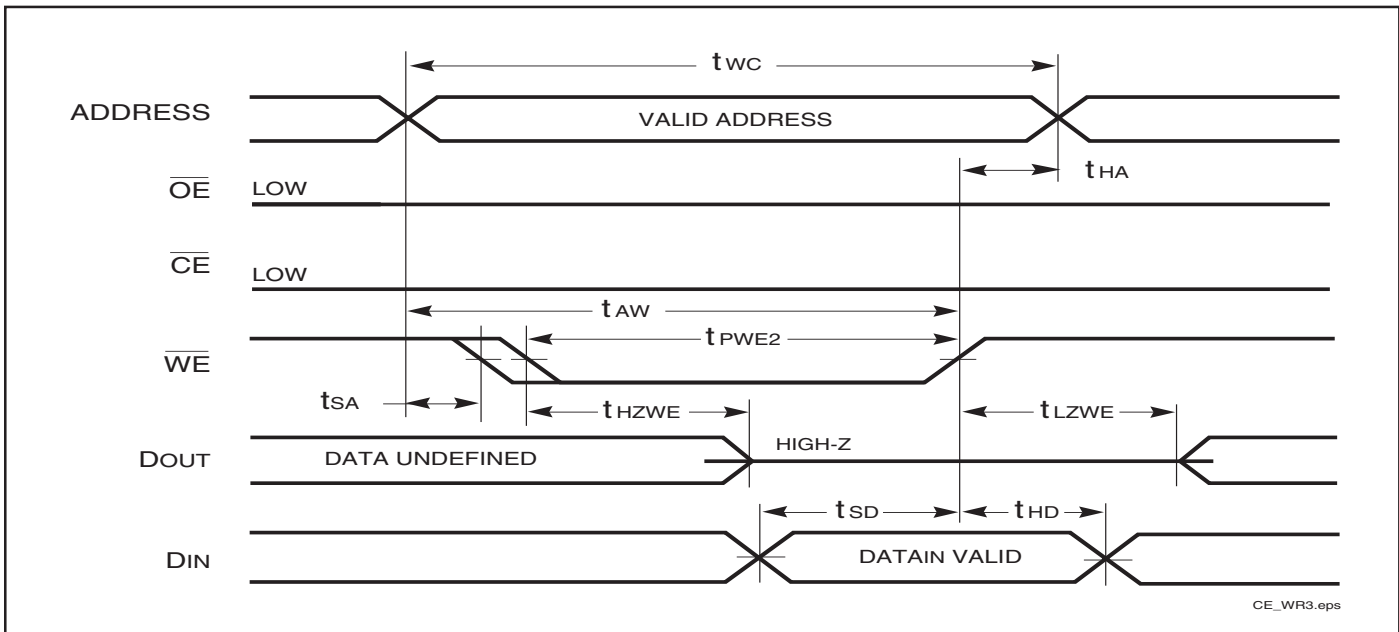

Notes:

1. The internal write time is defined by the overlap of  $\overline{CE}$  LOW and  $\overline{WE}$  LOW. All signals must be in valid states to initiate a Write, but any one can go inactive to terminate the Write. The Data Input Setup and Hold timing are referenced to the rising or falling edge of the signal that terminates the Write.
2. I/O will assume the High-Z state if  $\overline{OE} > V_{IH}$ .

**DATA RETENTION SWITCHING CHARACTERISTICS**

Symbol	Parameter	Test Condition	Operations	Min.	Typ. <sup>(1)</sup>	Max.	Unit
V <sub>DR</sub>	V <sub>DD</sub> for Data Retention	See Data Retention Waveform		1.8	—	3.6	V
I <sub>DR</sub>	Data Retention Current	V <sub>DD</sub> = 1.8V, $\overline{CE} \geq V_{DD} - 0.2V$	COM. IND. AUTO.	— — —	6 6 6	20 50 75	μA
t <sub>SDR</sub>	Data Retention Setup Time	See Data Retention Waveform		0	—	—	ns
t <sub>RDR</sub>	Recovery Time	See Data Retention Waveform		t <sub>RC</sub>	—	—	ns

**Note:**

1. Typical values are measured at V<sub>DD</sub> = 2.5V, T<sub>A</sub> = 25°C. Not 100% tested.

**DATA RETENTION WAVEFORM ( $\overline{CE}$  Controlled)**

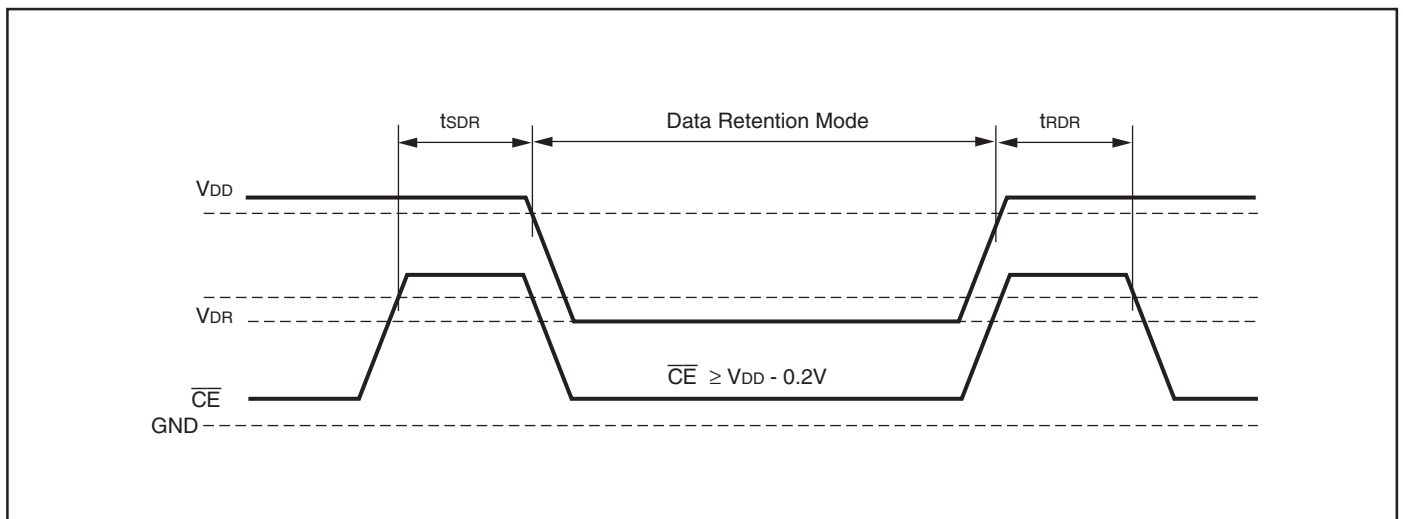

**ORDERING INFORMATION**

**Industrial Range: -40°C to +85°C**

<b>Speed (ns)</b>	<b>Order Part No.</b>	<b>Package</b>
12	IS63WV1024BLL-12TI	32-pin TSOP (Type II)
	IS63WV1024BLL-12TLI	32-pin TSOP (Type II), Lead-free
	IS63WV1024BLL-12HI	sTSOP (Type I) (8mm x13.4mm)
	IS63WV1024BLL-12HLI	sTSOP (Type I) (8mm x13.4mm), Lead-free
	IS63WV1024BLL-12JI	32-pin SOJ (300-mil)
	IS63WV1024BLL-12JLI	32-pin SOJ (300-mil), Lead-free
	IS63WV1024BLL-12BI	mBGA(6mmx8mm)
	IS63WV1024BLL-12BLI	mBGA(6mmx8mm), Lead-free

**Automotive Range (A3): -40°C to +85°C**

<b>Speed (ns)</b>	<b>Order Part No.</b>	<b>Package</b>
15 (12*)	IS64WV1024BLL-15TA3	32-pin TSOP (Type II)
	IS64WV1024BLL-15TLA3	32-pin TSOP (Type II), Lead-free
	IS64WV1024BLL-15HA3	sTSOP (Type I) (8mm x13.4mm)
	IS64WV1024BLL-15HLA3	sTSOP (Type I) (8mm x13.4mm), Lead-free
	IS64WV1024BLL-15BA3	mBGA(6mmx8mm)
	IS64WV1024BLL-15BLA3	mBGA(6mmx8mm), Lead-free

**Note:**

1. Speed = 12ns for  $V_{DD} = 3.3V \pm 10\%$ . Speed = 15ns for  $V_{DD} = 2.5V-3.6V$ .

# PACKAGING INFORMATION

## 300-mil Plastic SOJ

Package Code: J

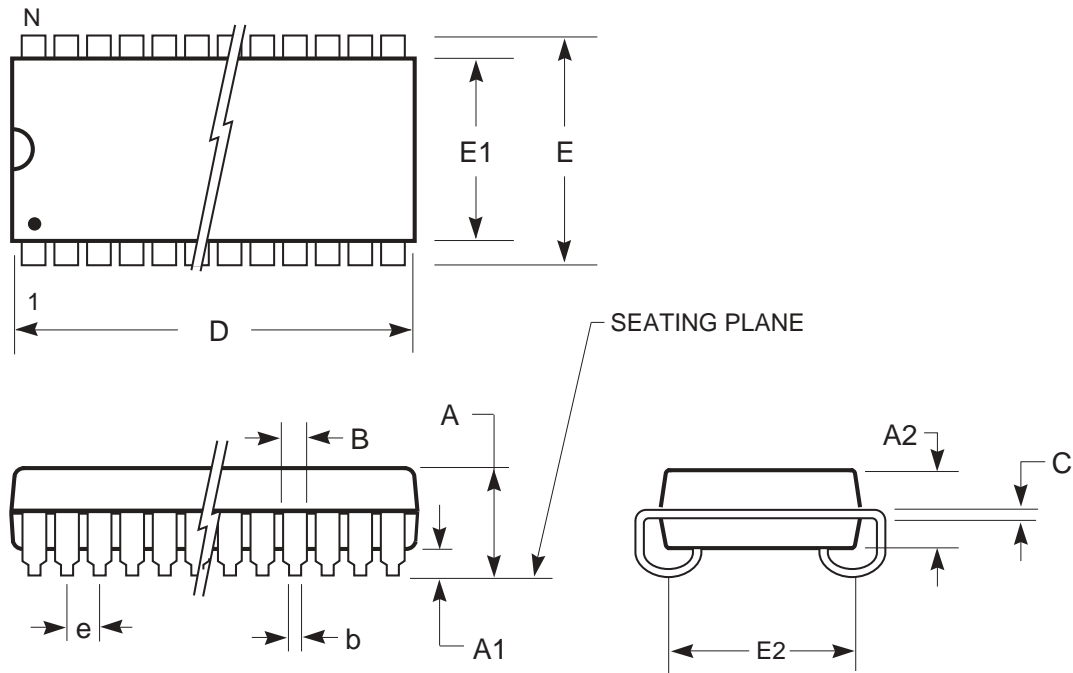

	MILLIMETERS			INCHES		
Sym.	Min.	Typ.	Max.	Min.	Typ.	Max.
N0.						
Leads	24/26					
A	—	—	3.56	—	—	0.140
A1	0.64	—	—	0.025	—	—
A2	2.41	—	2.67	0.095	—	0.105
b	0.41	—	0.51	0.016	—	0.020
B	0.66	—	0.81	0.026	—	0.032
C	0.20	—	0.25	0.008	—	0.010
D	17.02	—	17.27	0.670	—	0.680
E	8.26	—	8.76	0.325	—	0.345
E1	7.49	—	7.75	0.295	—	0.305
E2	6.27	—	7.29	0.247	—	0.287
e	1.27 BSC			0.050 BSC		

**Notes:**

1. Controlling dimension: inches, unless otherwise specified.
2. BSC = Basic lead spacing between centers.
3. Dimensions D and E1 do not include mold flash protrusions and should be measured from the bottom of the package.
4. Formed leads shall be planar with respect to one another within 0.004 inches at the seating plane.

Copyright © 2003 Integrated Silicon Solution, Inc. All rights reserved. ISSI reserves the right to make changes to this specification and its products at any time without notice. ISSI assumes no liability arising out of the application or use of any information, products or services described herein. Customers are advised to obtain the latest version of this device specification before relying on any published information and before placing orders for products.

# PACKAGING INFORMATION



300-mil Plastic SOJ

Package Code: J

MILLIMETERS				INCHES		
Sym.	Min.	Typ.	Max.	Min.	Typ.	Max.
NO. Leads				28		
A	—	—	3.56	—	—	0.140
A1	0.64	—	—	0.025	—	—
A2	2.41	—	2.67	0.095	—	0.105
b	0.41	—	0.51	0.016	—	0.020
B	0.66	—	0.81	0.026	—	0.032
C	0.20	—	0.25	0.008	—	0.010
D	18.29	—	18.54	0.720	—	0.730
E	8.26	—	8.76	0.325	—	0.345
E1	7.49	—	7.75	0.295	—	0.305
E2	6.27	—	7.29	0.247	—	0.287
e	1.27 BSC			0.050 BSC		

MILLIMETERS				INCHES		
Sym.	Min.	Typ.	Max.	Min.	Typ.	Max.
NO. Leads				32		
A	—	—	3.56	—	—	0.140
A1	0.64	—	—	0.025	—	—
A2	2.41	—	2.67	0.095	—	0.105
b	0.41	—	0.51	0.016	—	0.020
B	0.66	—	0.81	0.026	—	0.032
C	0.20	—	0.25	0.008	—	0.010
D	20.83	—	21.08	0.820	—	0.830
E	8.26	—	8.76	0.325	—	0.345
E1	7.49	—	7.75	0.295	—	0.305
E2	6.27	—	7.29	0.247	—	0.287
e	1.27 BSC			0.050 BSC		

## PACKAGING INFORMATION

Plastic STSOP - 32 pins  
 Package Code: H (Type I)

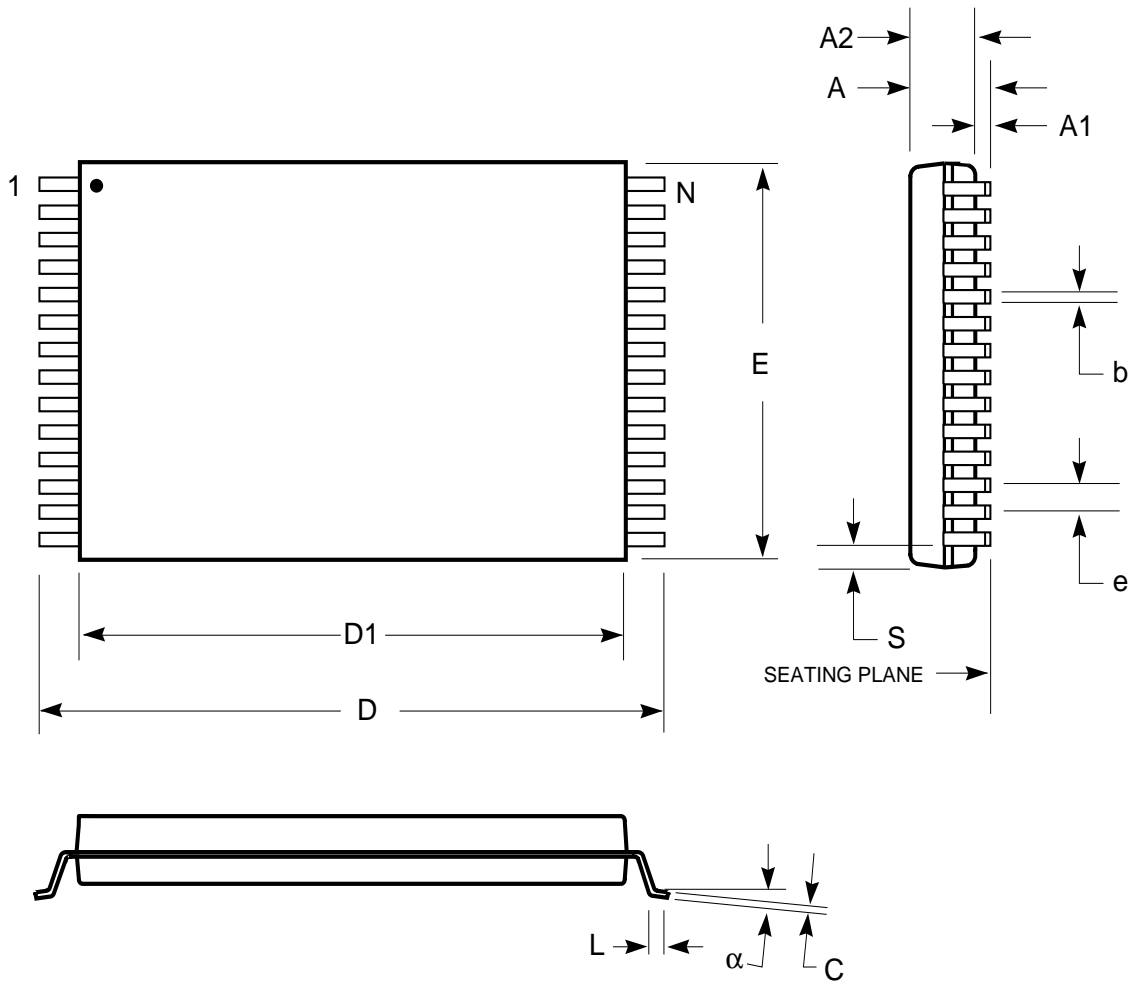

Plastic STSOP (H - Type I)				
	Millimeters		Inches	
Symbol	Min	Max	Min	Max
Ref. Std.				
N	32			
A	—	1.25	—	0.049
A1	0.05	—	0.002	—
A2	0.95	1.05	0.037	0.041
b	0.17	0.23	0.007	0.009
C	0.14	0.16	0.0055	0.0063
D	13.20	13.60	0.520	0.535
D1	11.70	11.90	0.461	0.469
E	7.90	8.10	0.311	0.319
e	0.50 BSC		0.020 BSC	
L	0.30	0.70	0.012	0.028
S	0.28 Typ.		0.011 Typ.	
alpha	0°	5°	0°	5°

**Notes:**

1. Controlling dimension: millimeters, unless otherwise specified.
2. BSC = Basic lead spacing between centers.
3. Dimensions D1 and E do not include mold flash protrusions and should be measured from the bottom of the package.
4. Formed leads shall be planar with respect to one another within 0.004 inches at the seating plane.

# PACKAGING INFORMATION



## Mini Ball Grid Array Package Code: B (48-pin)

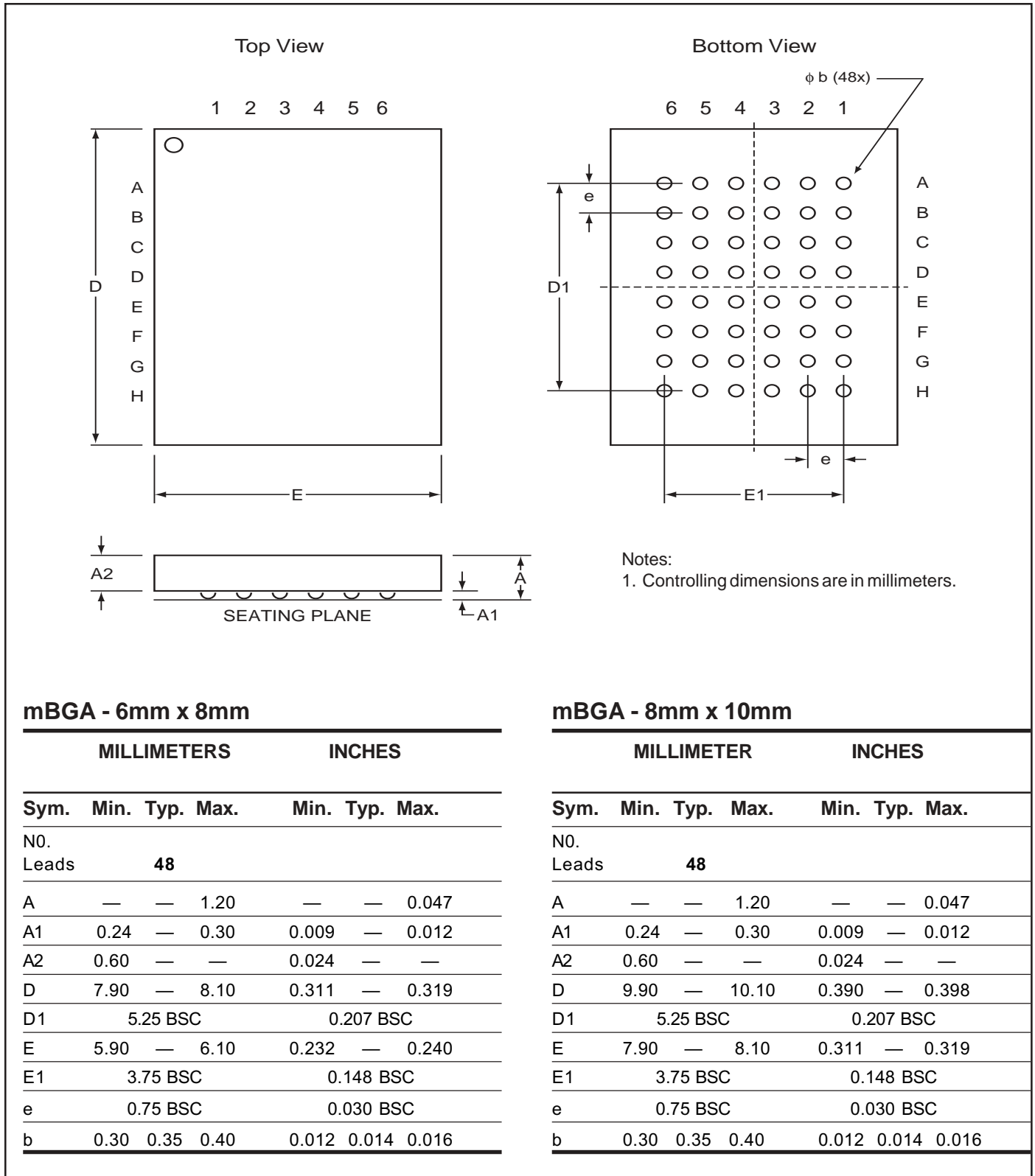

Copyright © 2003 Integrated Silicon Solution, Inc. All rights reserved. ISSI reserves the right to make changes to this specification and its products at any time without notice. ISSI assumes no liability arising out of the application or use of any information, products or services described herein. Customers are advised to obtain the latest version of this device specification before relying on any published information and before placing orders for products.

Integrated Silicon Solution, Inc. — [www.issi.com](http://www.issi.com) — 1-800-379-4774

Rev. D  
01/15/03



# PACKAGING INFORMATION



## Plastic TSOP Package Code: T (Type II)



### Notes:

1. Controlling dimension: millimeters, unless otherwise specified.
2. BSC = Basic lead spacing between centers.
3. Dimensions D and E1 do not include mold flash protrusions and should be measured from the bottom of the package.
4. Formed leads shall be planar with respect to one another within 0.004 inches at the seating plane.

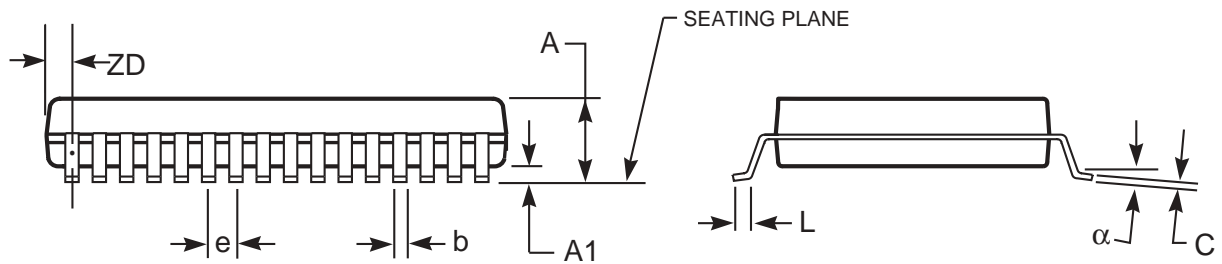

Plastic TSOP (T - Type II)

Symbol	Millimeters		Inches		Millimeters		Inches		Millimeters		Inches	
	Min	Max	Min	Max	Min	Max	Min	Max	Min	Max	Min	Max
Ref. Std.												
No. Leads (N)	32				44				50			
A	—	1.20	—	0.047	—	1.20	—	0.047	—	1.20	—	0.047
A1	0.05	0.15	0.002	0.006	0.05	0.15	0.002	0.006	0.05	0.15	0.002	0.006
b	0.30	0.52	0.012	0.020	0.30	0.45	0.012	0.018	0.30	0.45	0.012	0.018
C	0.12	0.21	0.005	0.008	0.12	0.21	0.005	0.008	0.12	0.21	0.005	0.008
D	20.82	21.08	0.820	0.830	18.31	18.52	0.721	0.729	20.82	21.08	0.820	0.830
E1	10.03	10.29	0.391	0.400	10.03	10.29	0.395	0.405	10.03	10.29	0.395	0.405
E	11.56	11.96	0.451	0.466	11.56	11.96	0.455	0.471	11.56	11.96	0.455	0.471
e	1.27 BSC		0.050 BSC		0.80 BSC		0.032 BSC		0.80 BSC		0.031 BSC	
L	0.40	0.60	0.016	0.024	0.41	0.60	0.016	0.024	0.40	0.60	0.016	0.024
ZD	0.95 REF		0.037 REF		0.81 REF		0.032 REF		0.88 REF		0.035 REF	
alpha	0°	5°	0°	5°	0°	5°	0°	5°	0°	5°	0°	5°

Copyright © 2003 Integrated Silicon Solution, Inc. All rights reserved. ISSI reserves the right to make changes to this specification and its products at any time without notice. ISSI assumes no liability arising out of the application or use of any information, products or services described herein. Customers are advised to obtain the latest version of this device specification before relying on any published information and before placing orders for products.