

GaAlAs HIGH POWER T-1 3/4 PACKAGE INFRARED EMITTING DIODE

MIE-534H4

Description

The MIE-534H4 is a GaAlAs infrared LED having a peak wavelength at 850nm. It features ultra-high power, high response speed and molded package with higher radiant intensity. In addition to improving the S/N ratio in applied optical systems, the MIE-534H4 has greatly improved long-distance characteristics as well as significantly increased its range of applicability.

Features

- Ultra-High radiant intensity
- High response speed
- Standard T-1 3/4 (ϕ 5mm) package
- Peak wavelength $\lambda_p = 850$ nm
- Radiant angle : 30°

Application

- Data communication
- SIR

Absolute Maximum Ratings

'@ $T_A = 25^\circ\text{C}$

Parameter	Maximum Rating	Unit
Power Dissipation	120	mW
Peak Forward Current(300pps,10 μ s pulse	1	A
Continuous Forward Current	100	mA
Reverse Voltage	5	V
Operating Temperature Range	-55 $^\circ\text{C}$ to +100 $^\circ\text{C}$	
Storage Temperature Range	-55 $^\circ\text{C}$ to +100 $^\circ\text{C}$	
Lead Soldering Temperature	260 $^\circ\text{C}$ for 5 seconds	

Package Dimensions

Unit: mm (inches)

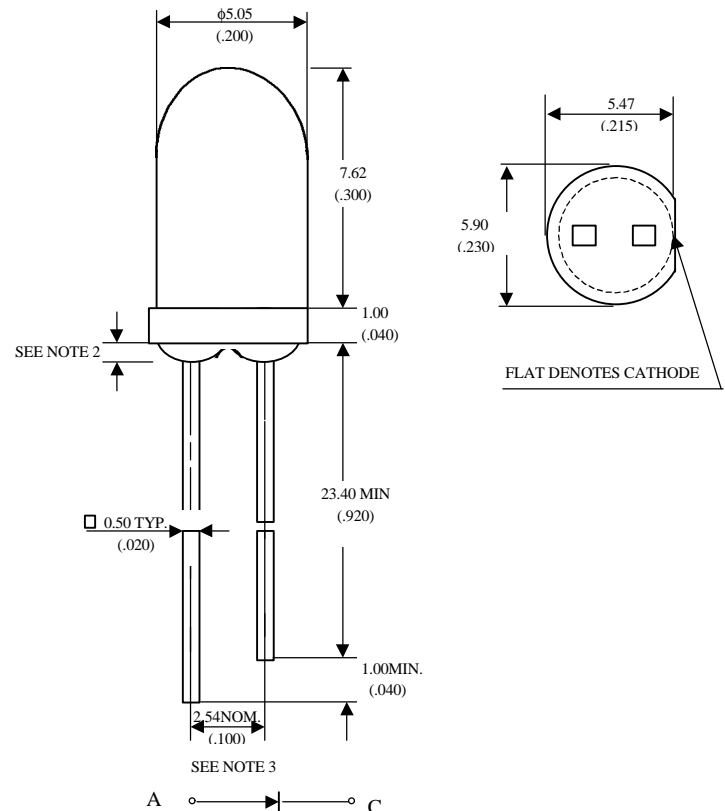

Notes :

1. Tolerance is ± 0.25 mm (.010") unless otherwise noted.
2. Protruded resin under flange is 1.5 mm (.059") max.
3. Lead spacing is measured where the leads emerge from the package.

UNI

Unity Opto Technology Co., Ltd.

11/17/2000

Optical-Electrical Characteristics

@ T_A=25°C

Parameter	Test Conditions	Symbol	Min.	Typ .	Max.	Unit
Radiant Intensity	I _F =20mA	I _e		4.2		mW/sr
Forward Voltage	I _F =50mA	V _F		1.5	1.8	V
Reverse Current	V _R =5V	I _R			100	μA
Peak Wavelength	I _F =20mA	λ _p		850		nm
Spectral Bandwidth	I _F =20mA	Δλ		30		nm
View Angle	I _F =20mA	2 θ _{1/2}		30		deg .
Rise Time	I _F =50mA	Tr		20		nsec
Fall Time	I _F =50mA	Tf		30		nsec

Typical Optical-Electrical Characteristic Curves

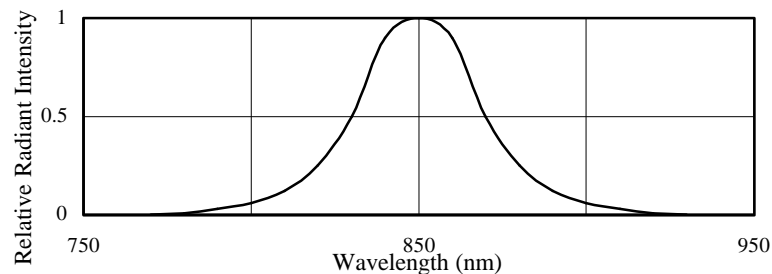

FIG.1 SPECTRAL DISTRIBUTION

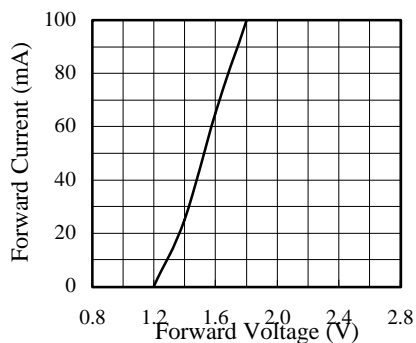

FIG.2 FORWARD CURRENT VS. FORWARD VOLTAGE

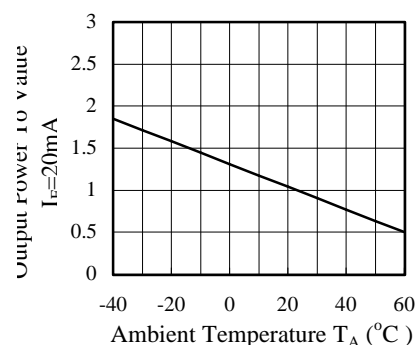

FIG.3 RELATIVE RADIANT INTENSITY VS. AMBIENT TEMPERATURE

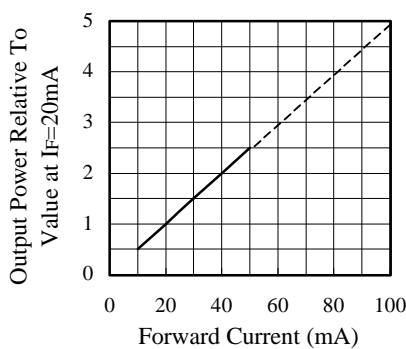

FIG.4 RELATIVE RADIANT INTENSITY VS. FORWARD CURRENT

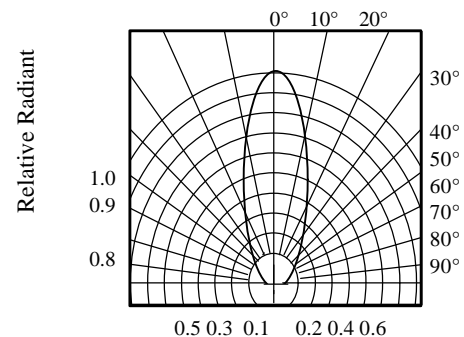

FIG.5 RADIATION DIAGRAM