

E2V Technologies

CX1594 Deuterium Filled, Hollow Anode, Five-Gap Ceramic Thyatron

The data to be read in conjunction with the Hydrogen Thyatron Preamble.

ABRIDGED DATA

Hollow anode, deuterium filled, five-gap thyatron with ceramic envelope, featuring high peak current, high rate of rise of current, low jitter and voltage/current reversal.

The patented hollow anode structure enables the tube to cope with inverse voltage and current without consequent reduction in its high voltage hold-off capability due to electrode damage.

A reservoir normally operated from a separate heater supply is incorporated. The reservoir heater voltage can be adjusted to a value consistent with anode voltage hold-off in order to achieve the fastest rate of rise of current possible from the tube in the circuit.

Modulator Service

Peak anode voltage (see note 1)	150	kV max
Peak forward anode current	10	kA max
Peak reverse anode current	5	kA max
Average anode current	3.0	A max

Crowbar Service

Peak anode voltage (see note 1)	125	kV max
Peak forward anode current	40	kA max
Peak reverse anode current	20	kA max
Conducted charge	18	C max

GENERAL

Electrical

Cathode (connected internally to one end of heater)	oxide coated
Cathode heater voltage	6.3 $\begin{smallmatrix} + 0.3 \\ - 0.0 \end{smallmatrix}$ V
Cathode heater current	40 A
Reservoir heater voltage (see note 2)	5.0 V
Reservoir heater current	10 A
Tube heating time (minimum)	15 min
Inter-electrode capacitances (each gap)	40 pF approx

Mechanical

Seated height (flange to flange)	566.0 mm (22.283 inches) max
Clearance required below flanges	57.15 mm (2.250 inches) min
Overall diameter (mounting flange)	152.4 mm (6.000 inches) nom
Net weight	13 kg (29 pounds) approx
Mounting position (see note 3)	any
Tube connections	see outline

Cooling

For all applications, cooling by oil or coolant immersion is desirable. Further information is contained in the relevant section of the Preamble.

At and below 55 kV the CX1594 may be cooled by forced-air directed mainly onto the base, and the ceramic envelope should be maintained below the maximum rated temperature. An air flow of at least 2.83 m³/min (100 ft³/min), depending on the mechanical layout, will be necessary to keep the tube operating temperatures under the limits specified below.

In addition to 300 W of heater power, the tube dissipates from 100 W per ampere average anode current, rising to 300 W/A at the highest rates of rise and fall of anode current.

The cathode end of the tube must be cooled whenever heater voltages are applied, since the cathode flange will reach a temperature of 120 °C above ambient in the absence of cooling.

Envelope temperature:

ceramic, anode and grids	150 °C max
cathode flange and base	120 °C max

MAXIMUM AND MINIMUM RATINGS

These ratings cannot necessarily be used simultaneously, and no individual rating must be exceeded.

Anode (Pulse Modulator Service) (See notes 4 and 5)

	Min	Typical	Max	
Peak forward or inverse anode voltage (see notes 1 and 6)	-	-	150	kV
Peak forward anode current	-	-	10	kA
Peak reverse anode current	-	-	5	kA
Average anode current	-	-	3.0	A
Rate of rise of anode current (see notes 7 and 8)	-	10	-	kA/ μ s
Pulse repetition rate (see note 4)	-	100	-	pps

Anode (Single-Shot or Crowbar Service) (See note 9)

DC forward anode voltage	125	kV max
Peak anode current	40	kA max
Conducted charge:		
capacitor discharge	0.6	C max
crowbar service (see note 10)	18	C max
Repetition frequency	1 pulse per 10 s	max

Grid 2

	Min	Max	
Unloaded grid 2 drive pulse voltage (see note 11)	500	2000	V
Grid 2 pulse duration	1.0	-	μ s
Rate of rise of grid 2 pulse (see note 8)	10	-	kV/ μ s
Grid 2 pulse delay	0.5	3.0	μ s
Peak inverse grid 2 voltage	-	450	V
Loaded grid 2 bias voltage	-50	-150	V
Forward impedance of grid 2 drive circuit	50	500	Ω

Grid 1 – DC Primed (See note 9)

DC grid 1 unloaded priming voltage	75	150	V
DC grid 1 priming current	75	150	mA

Grid 1 – Pulsed (See notes 5, 9 and 12)

Unloaded grid 1 drive pulse voltage (see note 11)	400	1000	V
Grid 1 pulse duration	2.0	-	μ s
Rate of rise of grid 1 pulse (see note 8)	1.0	-	kV/ μ s
Peak inverse grid 1 voltage	-	450	V
Loaded grid 1 bias voltage	-	see note 12	
Peak grid 1 drive current	0.5	1.5	A

Cathode

	Min	Max	
Heater voltage	6.3	+0.3 -0.0	V
Heating time	15	-	min

Reservoir

Heater voltage (see note 2)	4.5	6.5	V
Heating time	15	-	min

Environmental

Ambient temperature	-50	+90	$^{\circ}$ C
Altitude	-	3	km
	-	10 000	ft

CHARACTERISTICS

	Min	Typical	Max	
Critical DC anode voltage for conduction (see note 13)	-	7.0	10.0	kV
Anode delay time (see notes 13 and 14)	-	0.15	0.35	μ s
Anode delay time drift (see notes 13 and 15)	-	15	50	ns
Time jitter (see note 13)	-	1.0	5.0	ns
Cathode heater current (at 6.3 V)	35	40	45	A
Reservoir heater current (at 5.0 V)	8.0	10	12	A

NOTES

- At and below 55 kV the CX1594 may be operated in air. Above this level the tube must be operated in oil or coolant immersed.
- The reservoir heater must be decoupled with suitable capacitors to avoid damage by spike voltages. **The recommended reservoir heater voltage is stamped on individual tube envelopes.**
- The tube must be mounted using its mounting flange.
- Triggered charging techniques are recommended because the tube has a relatively long recovery time (100 - 200 μ s).
- Pre-pulsing of grid 1 is recommended for modulator and high rate of rise of current applications.
- This is the maximum hold-off voltage in either direction before the tube is triggered. The maximum permissible peak forward voltage for instantaneous starting is 100 kV and there must be no overshoot.
- For single-shot or burst mode applications this parameter can exceed 100 kA/ μ s. The ultimate value which can be attained depends to a large extent upon the external circuit.
- This rate of rise refers to that part of the leading edge of the pulse between 25% and 75% of the pulse amplitude.

9. When DC priming is used on grid 1, a negative bias of 100 to 150 V must be applied to grid 2 to ensure anode voltage hold-off. DC priming is recommended for crowbar service.
10. In crowbar service, most of the coulombs are often in the power supply follow-on current rather than the storage capacitor discharge.
11. Measured with respect to cathode. When grid 1 is pulse driven, the last 0.25 μ s of the top of the grid 1 pulse must overlap the corresponding first 0.25 μ s of the top of the delayed grid 2 pulse. (See schematic diagram, page 5).
12. DC negative bias voltages must not be applied to grid 1. When grid 1 is pulse driven, the potential of grid 1 may vary between -10 and $+5$ V with respect to cathode potential during the period between the completion of recovery and the commencement of the succeeding grid pulse.
13. Typical figures are obtained on test using conditions of minimum grid 2 drive. Improved performance can be expected by increasing grid drive.
14. The time interval between the instant at which the rising unloaded grid 2 pulse reaches 25% of its pulse amplitude and the instant when anode conduction takes place.
15. The drift in delay time over a period from 10 seconds to 10 minutes after reaching full voltage.

HEALTH AND SAFETY HAZARDS

E2V Technologies hydrogen thyratrons are safe to handle and operate, provided that the relevant precautions stated herein are observed. E2V Technologies does not accept responsibility for damage or injury resulting from the use of electronic devices it produces. Equipment manufacturers and users must ensure that adequate precautions are taken. Appropriate warning labels and notices must be provided on equipments incorporating E2V Technologies devices and in operating manuals.



High Voltage

Equipment must be designed so that personnel cannot come into contact with high voltage circuits. All high voltage circuits and terminals must be enclosed and fail-safe interlock switches must be fitted to disconnect the primary power supply and discharge all high voltage capacitors and other stored charges before allowing access. Interlock switches must not be bypassed to allow operation with access doors open.



X-Ray Radiation

All high voltage devices produce X-rays during operation and may require shielding. The X-ray radiation from hydrogen thyratrons is usually reduced to a safe level by enclosing the equipment or shielding the thyatron with at least 1.6 mm ($1/16$ inch) thick steel panels.

Users and equipment manufacturers must check the radiation level under their maximum operating conditions.

SCHEMATIC DIAGRAM (Crowbar Service)

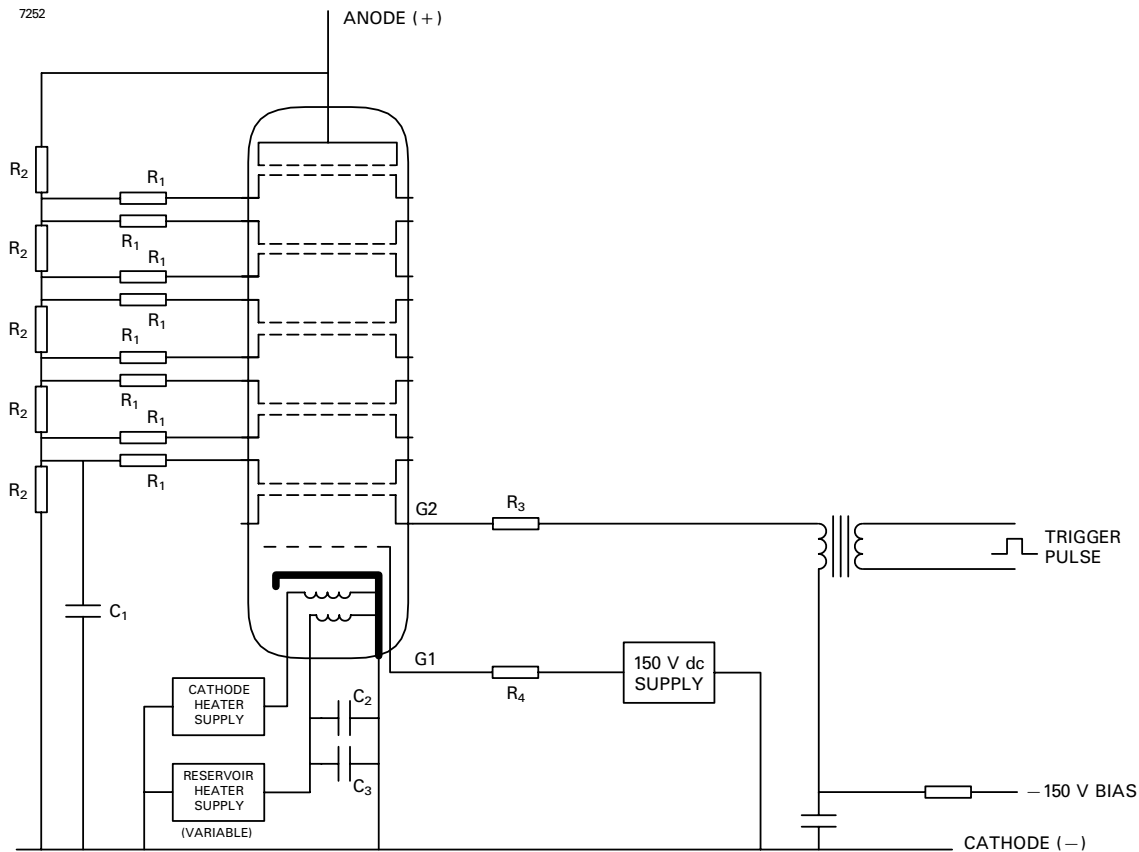

- R₁ = 470 Ω 12 W vitreous enamelled wirewound resistors.
- R₂ = 10 to 25 M Ω high voltage resistors with a power rating consistent with forward anode voltage.
- R₃ = Grid 2 series resistor. 12 W vitreous enamelled wirewound is recommended, of an impedance to match the grid 2 drive pulse circuit.
- R₄ = Grid 1 series resistor. 12 W vitreous enamelled wirewound is recommended.
- C₁ = 500 to 1000 pF capacitor with a voltage rating ≥ 30 kV.
- C₂, C₃ = Reservoir protection capacitors with a voltage rating ≥ 500 V;
- C₂ = 1000 pF low inductance (e.g. ceramic),
- C₃ = 1 μ F (e.g. polycarbonate or polypropylene).
- Components R₃, R₄, C₂, and C₃ should be mounted as close to the tube as possible.

SCHEMATIC DIAGRAM (Modulator Service)

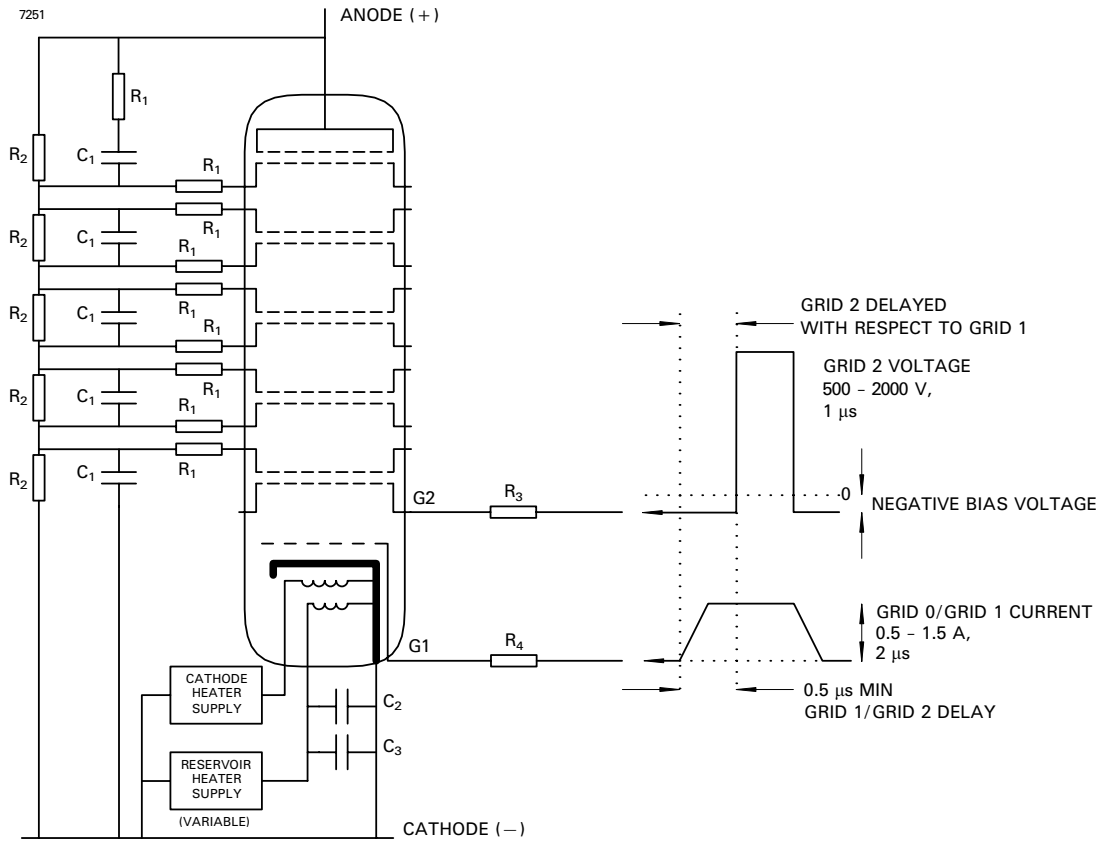

- R_1 = 470 Ω 12 W vitreous enamelled wirewound resistors.
- R_2 = 5 to 20 M Ω high voltage resistors with a power rating consistent with forward anode voltage.
- R_3 = Grid 2 series resistor. 12 W vitreous enamelled wirewound is recommended, of an impedance to match the grid 2 drive pulse circuit.
- R_4 = Grid 1 series resistor. 12 W vitreous enamelled wirewound is recommended, of an impedance to match the grid 1 drive pulse circuit.
- C_1 = 500 pF capacitors with a voltage rating equal to the peak forward voltage. These capacitors may be required to balance the voltages across each gap if the anode voltage rises in less than 5 ms.
- C_2, C_3 = Reservoir protection capacitors with a voltage rating ≥ 500 V;
 - C_2 = 1000 pF low inductance (e.g. ceramic),
 - C_3 = 1 μ F (e.g. polycarbonate or polypropylene).

Components R_3 , R_4 , C_2 , and C_3 should be mounted as close to the tube as possible.

OUTLINE

(All dimensions without limits are nominal)

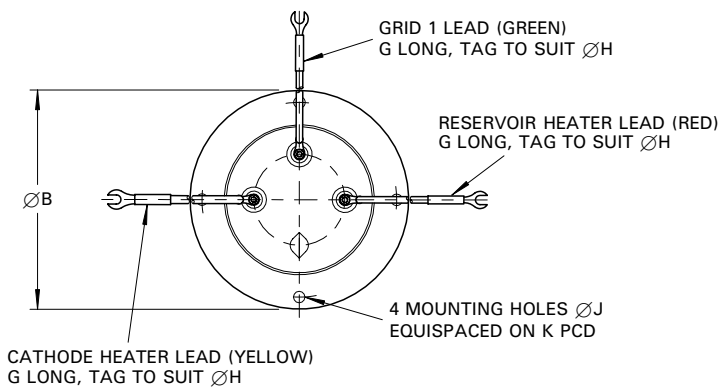
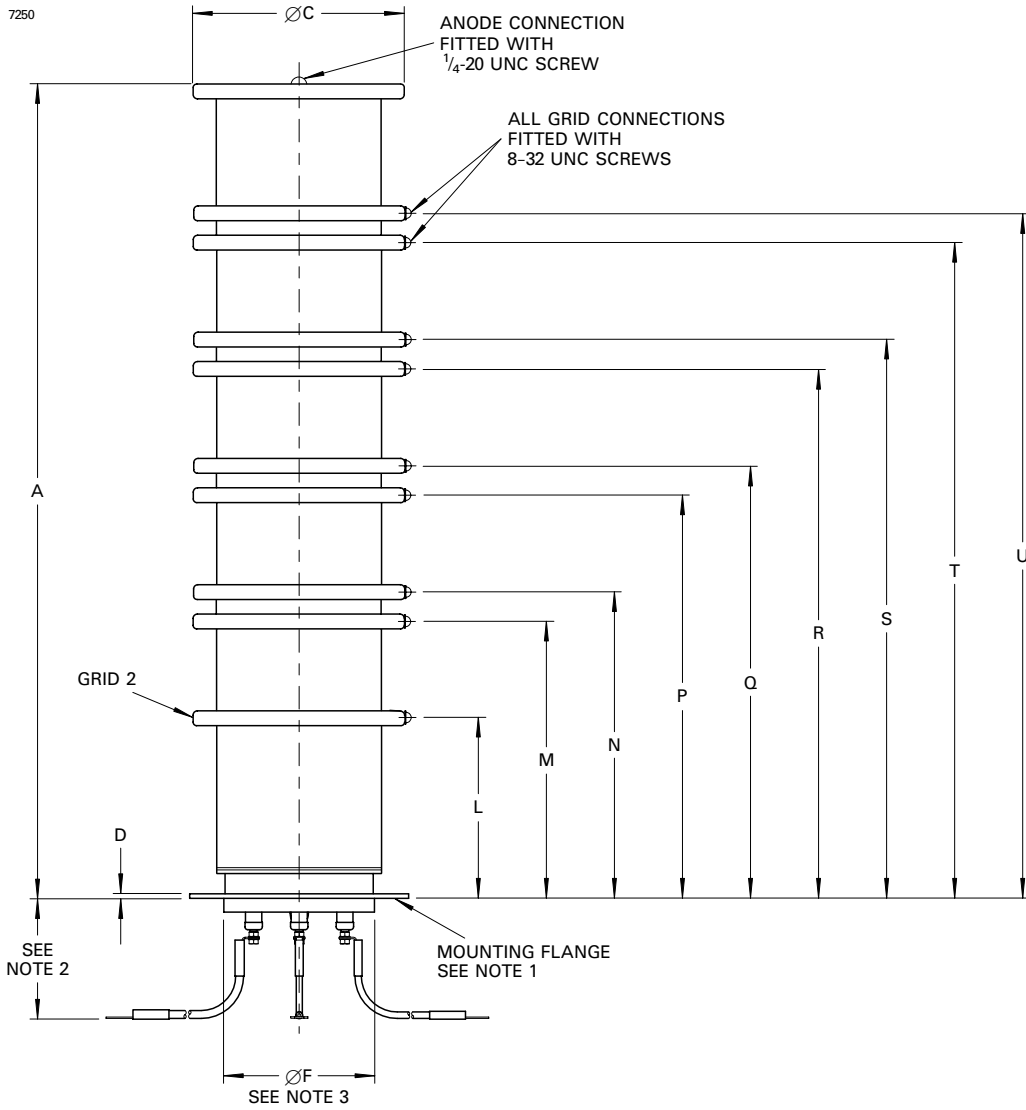

Ref	Millimetres	Inches
A	566.0 max	22.283 max
B	152.4	6.000
C	147.0	5.787
D	3.18	0.125
F	106.36 max	4.187 max
G	177.8 min	7.000 min
H	6.35	0.250
J	8.0	0.315
K	135.74	5.344
L	119.9	4.720
M	197.8	7.787
N	216.0	8.504
P	285.5	11.240
Q	303.7	11.957
R	373.2	14.693
S	391.4	15.409
T	460.9	18.146
U	479.3	18.870

Inch dimensions have been derived from millimetres.

Outline Notes

1. The mounting flange is the connection for the cathode, cathode heater return and reservoir heater return.
2. A minimum clearance of 57.15 mm (2.250 inches) must be allowed below the mounting flange.
3. The recommended mounting hole is 108 mm (4.25 inches) diameter.
4. The holes for all grid connections will be in line with the hole in the mounting flange to within 10° either side of the hole centre.

Whilst E2V Technologies has taken care to ensure the accuracy of the information contained herein it accepts no responsibility for the consequences of any use thereof and also reserves the right to change the specification of goods without notice. E2V Technologies accepts no liability beyond that set out in its standard conditions of sale in respect of infringement of third party patents arising from the use of tubes or other devices in accordance with information contained herein.