

Silicon Variable Capacitance Diode

BB 304A

Preliminary Data

- For FM tuners
- Monolithic chip with common cathode for perfect tracking of both diodes
- Uniform "square law" characteristics
- Ideal Hifi tuning device when used in Low-distortion back-to back configuration
- Color-coded capacitance subgroups available (see characteristics)

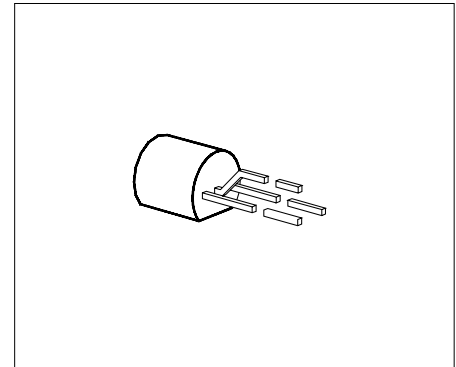

Type	Ordering Code (tape and reel)	Pin Configuration			Marking	Package
		1	2	3		
BB 304A	Q62702-B118	A1	C1/C2	A2	color coded capacitance groups	TO-92

Maximum Ratings

Parameter	Symbol	Values	Unit
Reverse voltage	V_R	18	V
Peak reverse voltage ($R \geq 10 \Omega$)	V_{RM}	20	V
Forward current $T_A \leq 60 \text{ }^\circ\text{C}$	I_F	50	mA
Storage temperature range	T_{stg}	- 55 ... + 150	$^\circ\text{C}$

Thermal Resistance

Junction-ambient	$R_{th JA}$	\leq	K/W
------------------	-------------	--------	-----

Electrical Characteristics

at $T_A = 25\text{ °C}$, unless otherwise specified.

Parameter	Symbol	Value			Unit
		min.	typ.	max.	
DC Characteristics					
Reverse current $V_R = 16\text{ V}$ $V_R = 16\text{ V}, T_A = 60\text{ °C}$	I_R	– –	– –	20 200	nA
Diode capacitance $V_R = 2\text{ V}, f = 1\text{ MHz}$	C_T	42	–	47.5	pF
Capacitance ratio $V_R = 2\text{ V} \dots 8\text{ V}, f = 1\text{ MHz}$	C_{T2}/C_{T8}	1.65	–	– 1.75	–
Series resistance $V_R = 38\text{ V}, f = 100\text{ MHz}$	r_S	–	0.25	0.4	Ω
Q factor $C_T = 38\text{ pF}, f = 100\text{ MHz}$	Q	100	170	–	–
Diode capacitance $V_R = 2\text{ V}, f = 1\text{ MHz}$ Subgroup: red yellow white green blue	C_T	42 43 44 45 46	– – – – –	43.5 44.5 45.5 46.5 47.5	pF

Package Outline

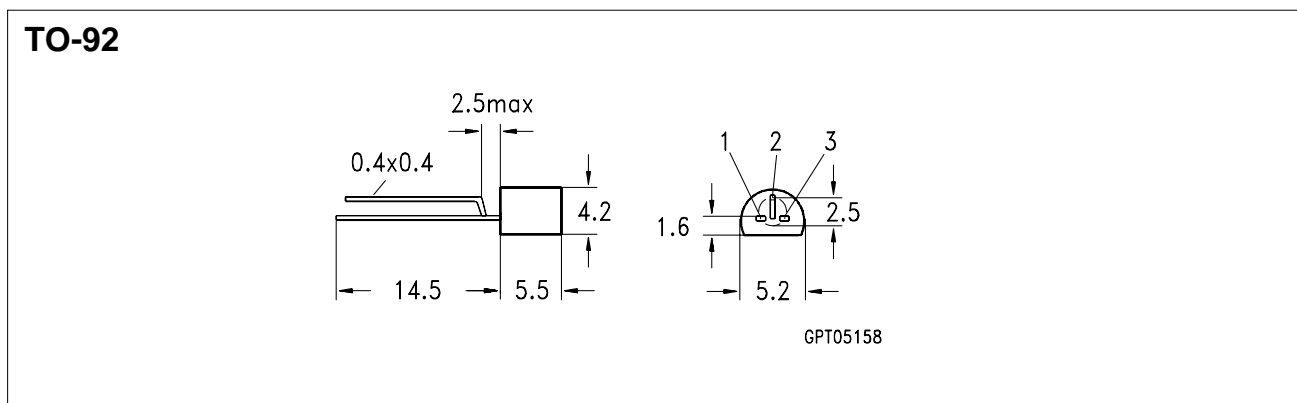

Diode capacitance $C_T = f(V_R)$
per diode $f = 1$ MHz

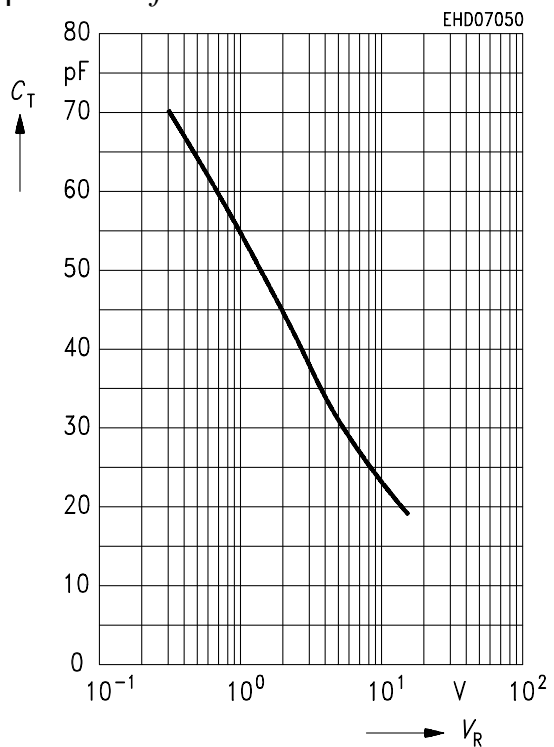

Capacitance ratio $C_T/C_{Tref} = f(V_R)$
per diode; $V_{ref} = 1$ V, 2 V, $f = 1$ MHz

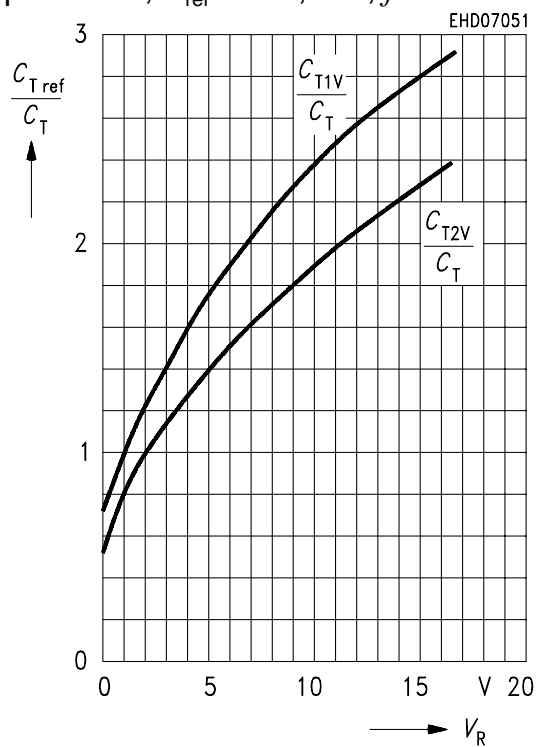

Temperature coefficient $T_{CC} = f(V_R)$
per diode, $f = 1$ MHz

