



P0120004P

1.5W GaAs Power FET (Pb-Free Type)

Technical Note

SUMITOMO ELECTRIC

◆ Features

- Up to 2.7 GHz frequency band
- Beyond +30 dBm output power
- Up to +45dBm Output IP3
- High Drain Efficiency
- 11dB Gain at 2.1GHz
- SOT-89 SMT Package
- Low Noise Figure



◆ Applications

- Wireless communication system
- Cellular, PCS, PHS, W-CDMA, WLAN

◆ Description

P0120004P is a high performance GaAs MESFET housed in a low-cost SOT-89 package. Our originally developed "pulse-doped" channel structure has realized low distortion, which leads to high IP3. The channel structure also achieved an extremely low noise figure. The details about pulse-doped FET channel are described in our products catalog. Utilization of AuSn die attach has realized a low and stable thermal resistance. **The lead frame is plated with Sn-Bi to make the device Pb-free.**

SEI's long history of manufacturing has cultivated high device reliability. The estimated MTTF of the FET is longer than 15years at Tj of 150°C. You can see the details in **Reliability and Quality Assurance.**

◆ Electrical Specifications (@Tc=25°C)

Parameter	Symbol	Test Conditions	Values			Units
			Min.	Typ.	Max.	
DC	Saturated Drain Current	Idss	Vds=3V, Vg=0V		1600	mA
	Transconductance	gm	Vds=6V, Ids=500mA		450	mS
	Pinchoff Voltage	Vp	Vds=6V, Ids=50mA		-3.0	V
	Gate-Source Breakdown Voltage	Vgs0	Igs0= -50μA		3.0	V
	Thermal Resistance	Rth	Channel-Case		22	°C/W
RF	Frequency	f			2.7	GHz
	Output Power @ 1dB Gain Compression	P1dB			32	dBm
	Small Signal Gain	G	Vds=6V Ids=400mA f=2.1GHz		11	dB
	Output IP3	IP3			45	dBm
	Power Added Efficiency	η _{add}			60	%

◆ Functional Diagram

Pin No.	Function
1	Input/Gate
2, 4	Ground
3	Output/Drain

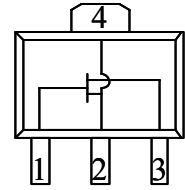

◆ Ordering Information

Part No	Description	Number of devices	Container
P0120004P	GaAs Power FET	1000	7" Reel
KP024J	2.11-2.17GHz Application Circuit	1	Anti-static Bag

◆ Absolute Maximum Ratings (@Tc=25°C)

Parameter	Symbol	Value	Units
Drain-Source Voltage	Vds	8	V
Gate-Source Voltage	Vgs	-4	V
Drain Current	Ids	Idss	---
RF Input Power (continuous)	Pin	25 (*)	dBm
Power Dissipation	Pt	4.3	W
Junction Temperature	Tj	125	°C
Storage Temperature	Tstg	-40 to +125	°C

Tc: Case Temperature. Operating the device beyond any of these values may cause permanent damage.

(*) Measured at 2.1GHz with our test fixture matched to IP3.



P0120004P

1.5W GaAs Power FET (Pb-Free Type)

Technical Note

SUMITOMO ELECTRIC

◆ Typical Characteristics

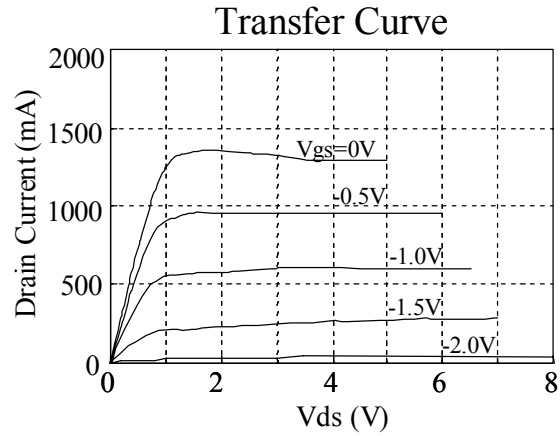
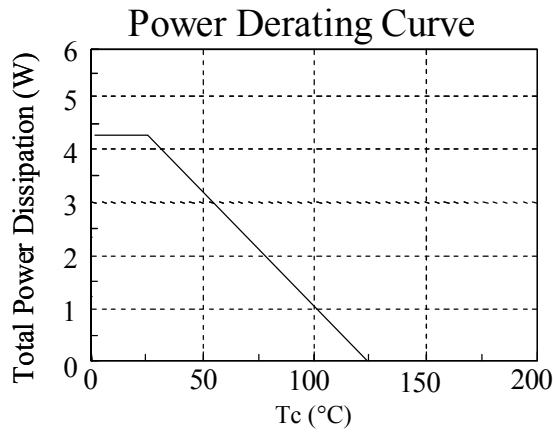

◆ Load-pull Characteristics (Typical Data)

Tc=25°C, Vds=6V, Ids=400mA, Common Source, Zo=50Ω (Calibrated to device leads)

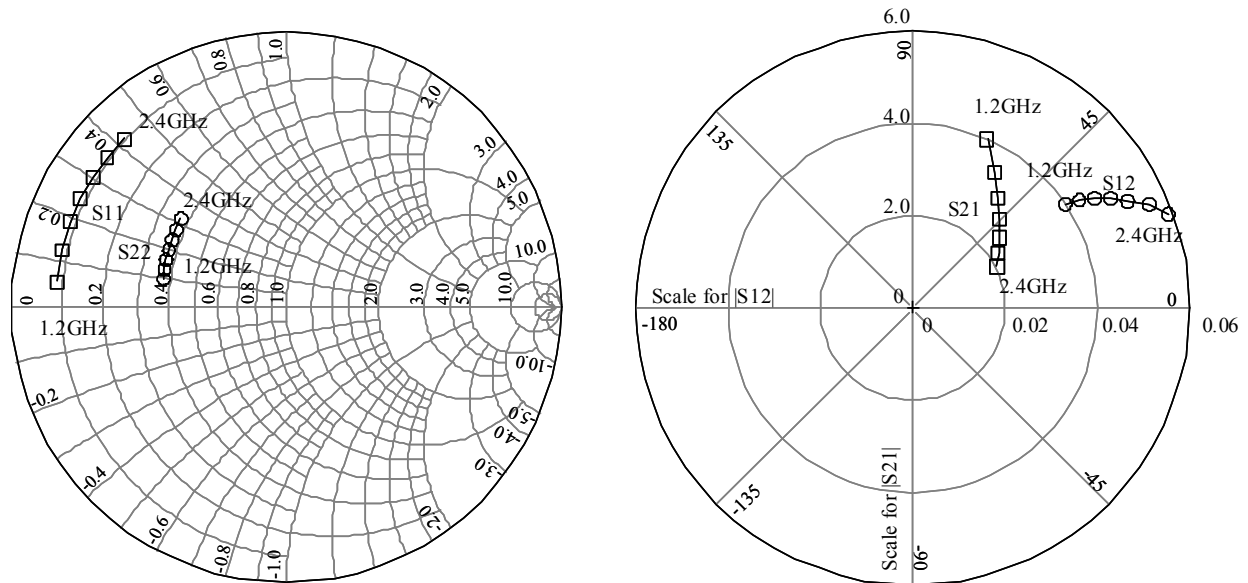



P0120004P

1.5W GaAs Power FET (Pb-Free Type)

Technical Note

SUMITOMO ELECTRIC

Tc=25°C, Vds=6V, Ids=350mA, Common Source, Zo=50Ω (Calibrated to device leads)

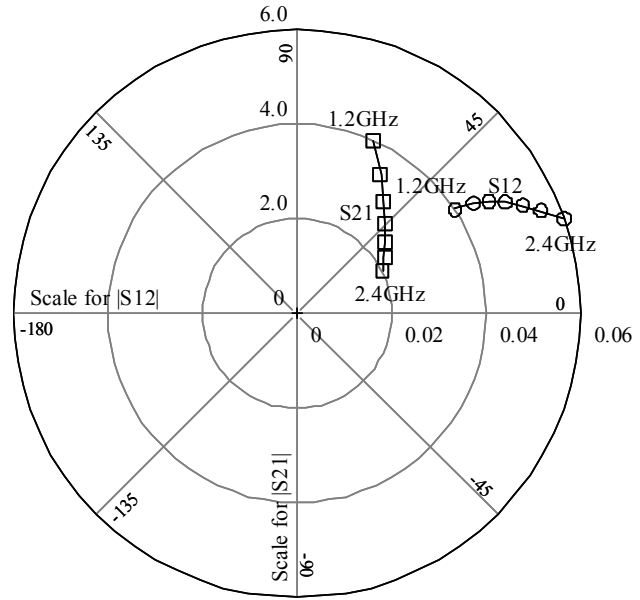
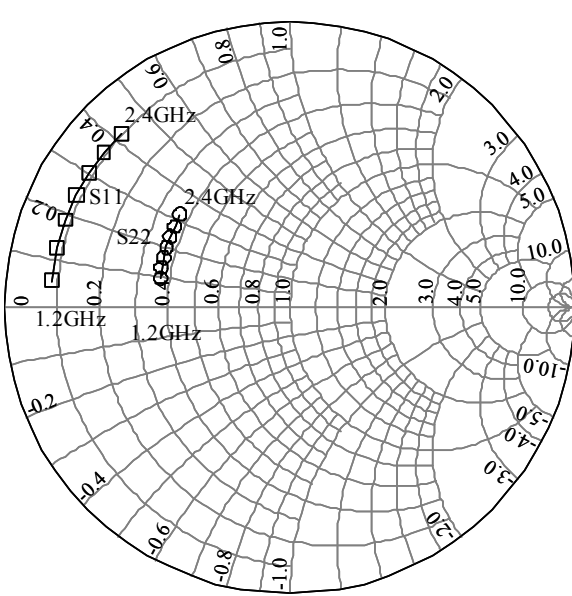

=400mA

Freq (GHz)	S11 Mag	S11 Ang	S21 Mag	S21 Ang	S12 Mag	S12 Ang	S22 Mag	S22 Ang
1.2	0.841	173.7	4.002	66.2	0.040	34.2	0.459	167.3
1.4	0.843	165.7	3.433	58.9	0.043	32.8	0.464	162.8
1.6	0.845	158.6	3.005	52.1	0.046	31.0	0.470	158.6
1.8	0.847	152.2	2.673	45.5	0.049	28.9	0.475	154.2
2.0	0.848	146.1	2.410	39.1	0.052	26.4	0.481	149.6
2.2	0.849	140.2	2.200	32.7	0.056	23.6	0.488	145.1
2.4	0.849	134.1	2.028	26.3	0.059	20.2	0.499	140.1

=350mA

Freq (GHz)	S11 Mag	S11 Ang	S21 Mag	S21 Ang	S12 Mag	S12 Ang	S22 Mag	S22 Ang
1.2	0.841	173.6	3.993	66.2	0.040	33.4	0.465	167.2
1.4	0.843	165.6	3.424	59.0	0.044	31.9	0.471	162.7
1.6	0.845	158.6	2.998	52.2	0.047	30.2	0.476	158.4
1.8	0.846	152.2	2.666	45.6	0.050	28.1	0.482	154.0
2.0	0.847	146.1	2.405	39.2	0.053	25.5	0.488	149.4
2.2	0.848	140.2	2.195	32.8	0.056	22.8	0.494	144.8
2.4	0.848	134.1	2.024	26.4	0.060	19.5	0.505	139.8

[Note] You can download the S-parameter list from our web site: www.sei.co.jp/GaAsIC/



P0120004P

1.5W GaAs Power FET (Pb-Free Type)

Technical Note

SUMITOMO ELECTRIC

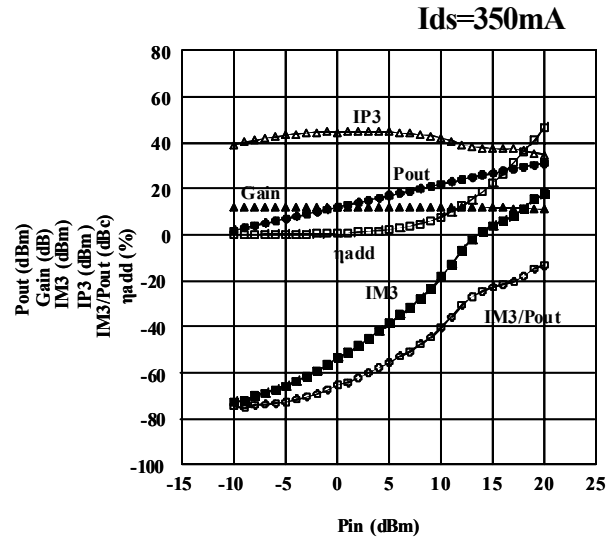
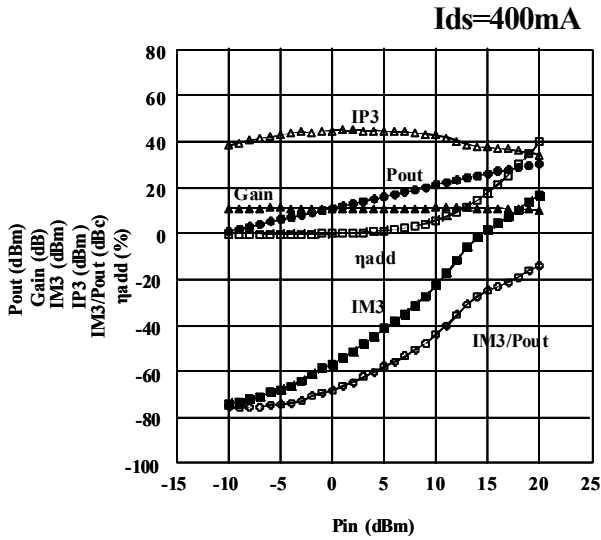

Device: P0120004P
 Frequency: f1=2.1GHz, f2=2.101GHz
 Bias: Vds=6V, Ids=400mA
 Source Matching: Mag 0.65 Ang -156.0°
 Load Matching: Mag 0.67 Ang -140.8°

Device: P0120004P
 Frequency: f1=2.1GHz, f2=2.101GHz
 Bias: Vds=6V, Ids=350mA
 Source Matching: Mag 0.65 Ang -156.0°
 Load Matching: Mag 0.635 Ang -142.2°

[Note] P_{out} and η_{add} are measured by one signal.

The data for the figures above were measured with the load impedance matched to IP3.

Id=400mA	Pin (dBm)	Pout (dBm)	Gain (dB)	IM3 (dBm)	IM3/Pout (dBc)	IP3 (dBm)	Id (mA)	ηadd (%)
	-10.0	1.5	11.5	-73.3	-74.8	38.9	406.0	0.1
	-5.0	6.6	11.6	-67.2	-73.8	43.6	402.8	0.2
	0.0	11.5	11.5	-56.3	-67.8	45.2	396.6	0.6
	5.0	16.6	11.6	-40.6	-57.2	45.1	384.9	1.8
	10.0	21.7	11.7	-21.6	-43.3	43.2	367.0	6.3
	15.0	26.5	11.5	2.2	-24.3	38.0	381.9	18.2
	20.0	30.8	10.8	17.3	-13.5	34.7	455.0	40.3

Id=350mA	Pin (dBm)	Pout (dBm)	Gain (dB)	IM3 (dBm)	IM3/Pout (dBc)	IP3 (dBm)	Id (mA)	ηadd (%)
	-10.0	2.0	12.0	-72.5	-74.5	39.0	356.6	0.1
	-5.0	7.1	12.1	-65.7	-72.8	43.5	353.3	0.2
	0.0	12.0	12.0	-53.3	-65.3	44.5	346.9	0.7
	5.0	17.0	12.0	-38.5	-55.5	44.7	336.4	2.3
	10.0	22.1	12.1	-18.3	-40.3	42.1	319.2	7.9
	15.0	26.9	11.9	4.1	-22.8	37.5	339.5	22.4
	20.0	31.0	11.0	17.8	-13.2	34.7	412.1	46.8



P0120004P

1.5W GaAs Power FET (Pb-Free Type)

Technical Note

SUMITOMO ELECTRIC

Tc=25°C, Vds=6V, Ids=400mA, Pin=5dBm

[Pout-Lstate]

f = 2.1GHz Γ_{pout} : 0.48∠172.8
Source : 0.81∠-152.1
Pout max : 17.5dBm

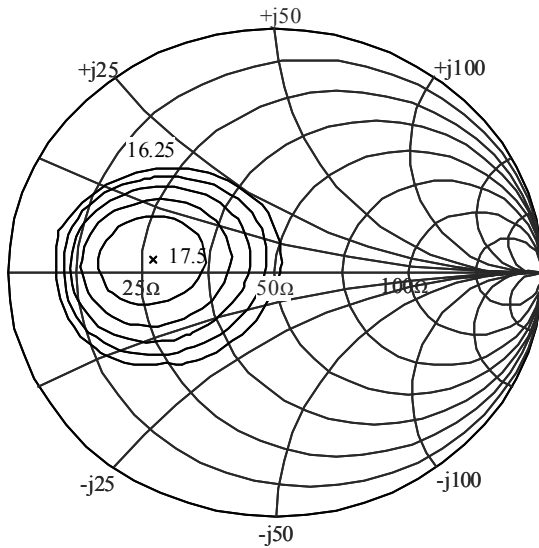

[IP3-Lstate]

f1 = 2.1GHz Γ_{IP3} : 0.69∠-141.8
f2 = 2.101GHz Source : 0.77∠-155.2
IP3 max : 45.6dBm

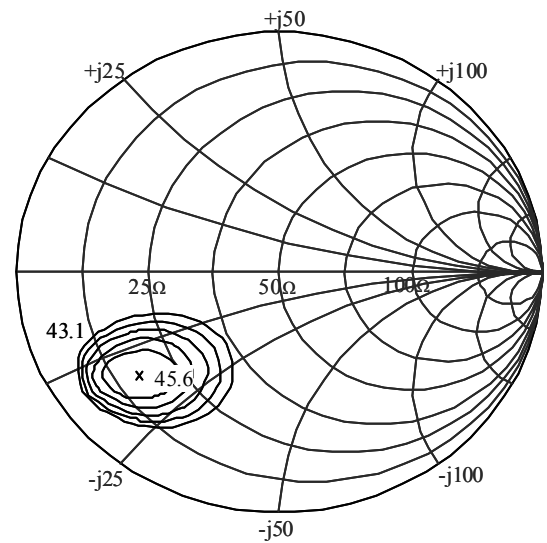

Tc=25°C, Vds=6V, Ids=350mA, Pin=5dBm

[Pout-Lstate]

f = 2.1GHz Γ_{pout} : 0.50∠177.2
Source : 0.81∠-152.1
Pout max : 17.95dBm

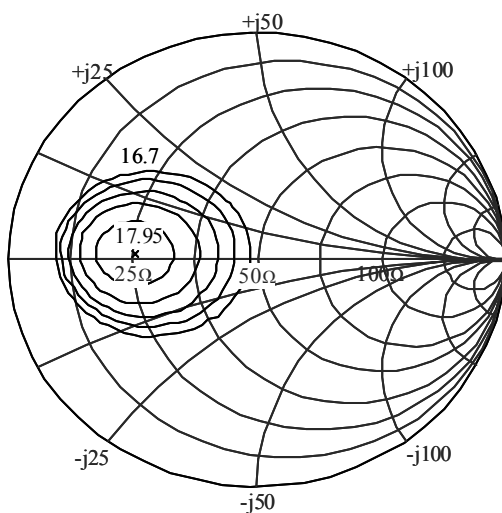

[IP3-Lstate]

f1 = 2.1GHz Γ_{IP3} : 0.66∠-142.0
f2 = 2.101GHz Source : 0.77∠-155.2
IP3 max : 43.9dBm

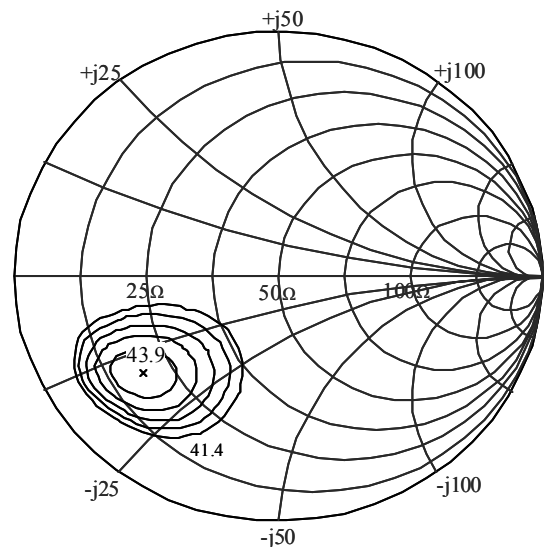



P0120004P

1.5W GaAs Power FET (Pb-Free Type)

Technical Note

SUMITOMO ELECTRIC

◆NF Characteristics

Ids=400mA

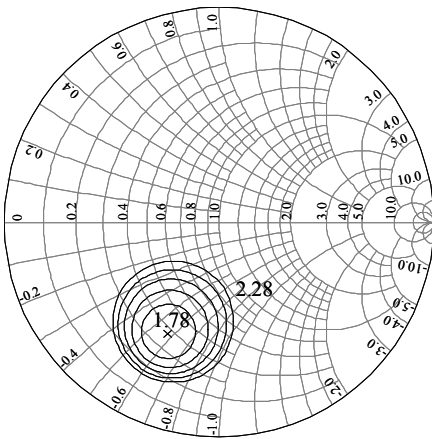

Ids=350mA

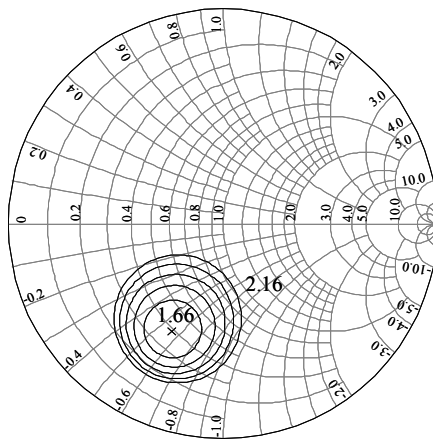

Ids=300mA

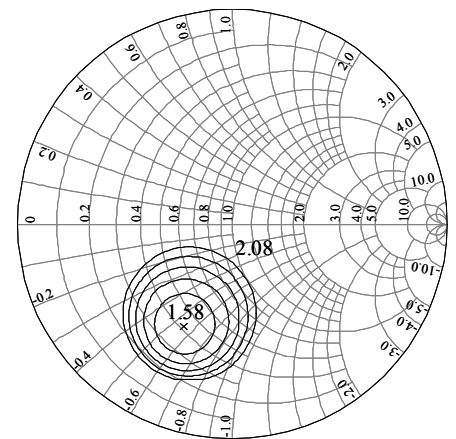

[Note] The data for Smith charts were measured at frequency of 2GHz and Tc of 25°C.

Vds=6V Ids=400mA

Freq. (GHz)	NFmin (dB)	Γ_{opt} Mag	Γ_{opt} Ang(deg)	Rn/50	Associated Gain(dB)
0.4	0.62	0.24	-58.4	0.09	20.7
0.6	0.55	0.30	17.2	0.13	18.9
0.8	0.69	0.35	66.2	0.16	17.2
1.0	0.87	0.43	101.1	0.14	15.9
1.2	1.13	0.48	132.9	0.10	14.7
1.4	1.14	0.56	159.1	0.05	14.0
1.6	1.21	0.61	-173.6	0.04	13.2
1.8	1.35	0.63	-147.0	0.10	12.4
2.0	1.78	0.57	-114.7	0.31	11.4

Vds=6V Ids=300mA

Freq. (GHz)	NFmin (dB)	Γ_{opt} Mag	Γ_{opt} Ang(deg)	Rn/50	Associated Gain(dB)
0.4	0.52	0.24	-65.3	0.08	20.6
0.6	0.42	0.27	8.6	0.12	18.7
0.8	0.58	0.29	60.5	0.13	16.9
1.0	0.72	0.39	98.0	0.12	15.7
1.2	0.97	0.43	130.4	0.10	14.5
1.4	0.99	0.52	156.8	0.05	13.8
1.6	1.06	0.56	-175.1	0.04	13.1
1.8	1.19	0.59	-148.9	0.08	12.3
2.0	1.58	0.53	-115.4	0.25	11.4

Vds=6V Ids=350mA

Freq. (GHz)	NFmin (dB)	Γ_{opt} Mag	Γ_{opt} Ang(deg)	Rn/50	Associated Gain(dB)
0.4	0.54	0.24	-65.0	0.08	20.6
0.6	0.47	0.28	12.9	0.12	18.8
0.8	0.78	0.19	65.8	0.16	16.4
1.0	0.85	0.39	100.7	0.12	15.7
1.2	1.04	0.45	132.2	0.10	14.7
1.4	1.07	0.54	158.3	0.05	14.0
1.6	1.12	0.58	-174.1	0.04	13.2
1.8	1.26	0.61	-147.7	0.09	12.4
2.0	1.66	0.56	-115.4	0.27	11.5

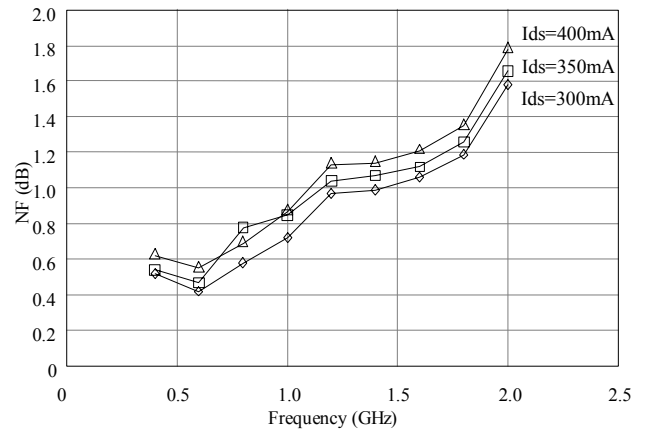

◆ Application Circuit : 2110-2170MHz

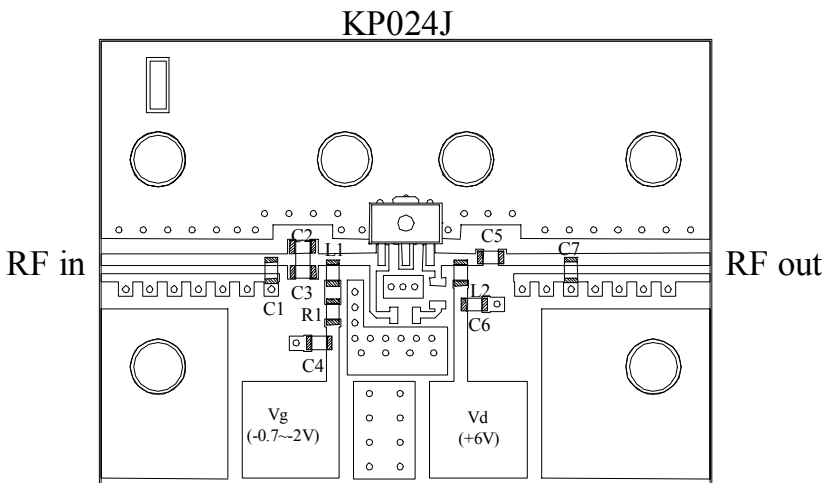
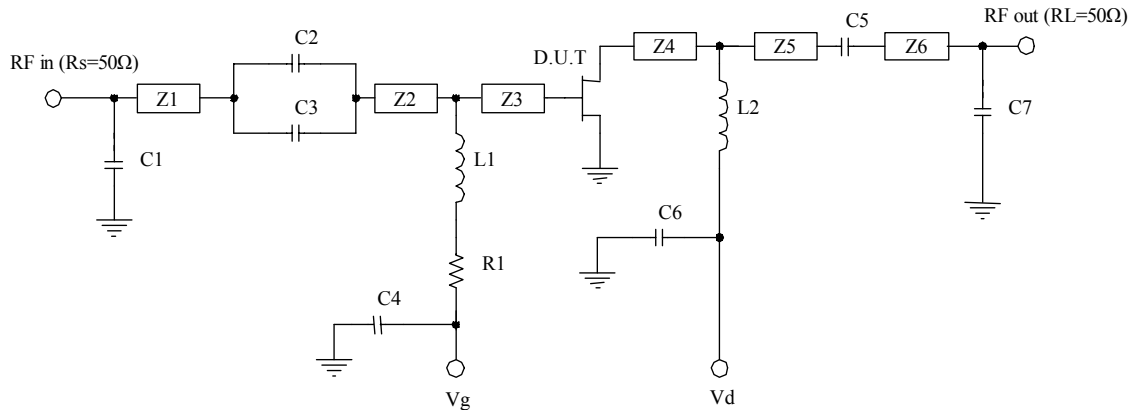

Ref. Des.	Value	Part Number
R1	82Ω	SUSUMU RR0816 series
C1	0.5pF	MURATA GRM18 series
C2	1pF	
C3	0.5pF	
C4	0.1μF	
C5	3pF	
C6	0.1μF	
C7	1pF	
L1	18nH	TOKO LL1608 series
L2	18nH	

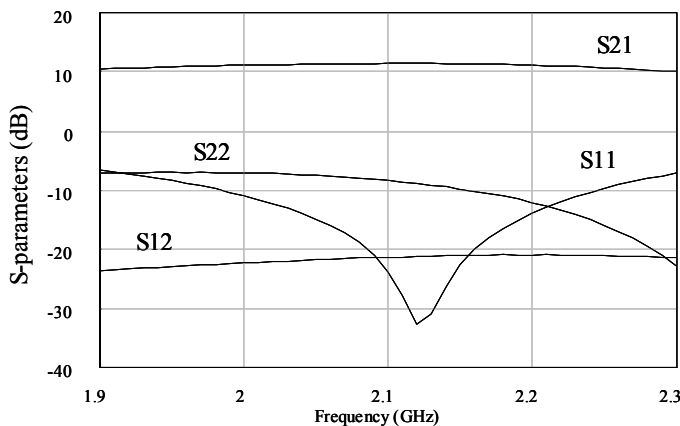

Ref. Designator	Electrical length @ 2.1GHz (deg)
Z1	4.54
Z2	4.08
Z3	13.61
Z4	8.62
Z5	6.38
Z6	18.15

All microstrip lines have a line impedance of 50Ω.



P0120004P

1.5W GaAs Power FET (Pb-Free Type)

Technical Note

SUMITOMO ELECTRIC

[Typical Performance]

KP024J Application Circuit

V_{ds}=6V, I_{ds}=400mA, T_c=25°C

Frequency characteristics were measured with P_{out} at 17dBm.

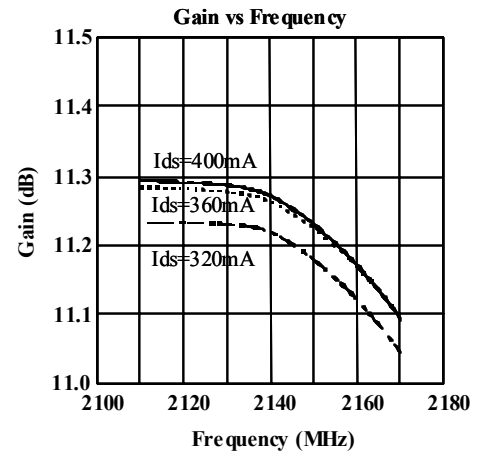
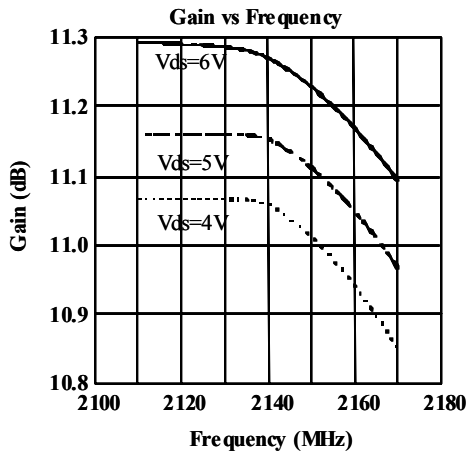
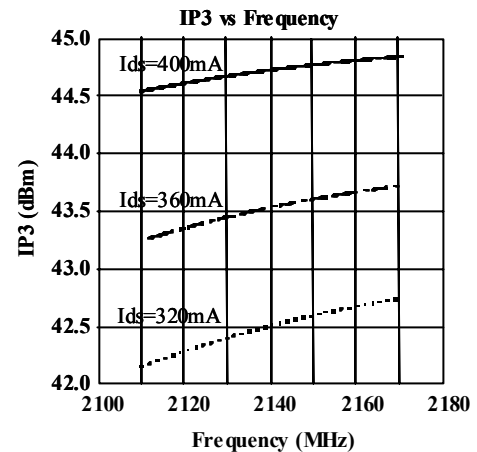
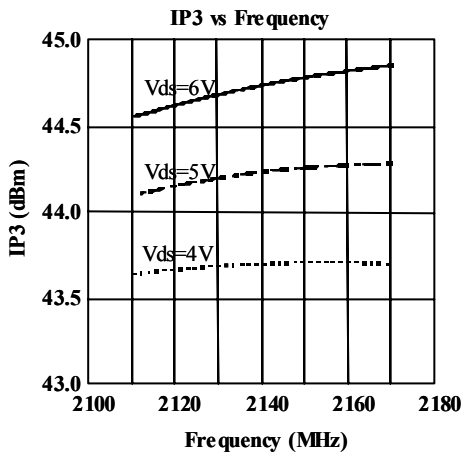
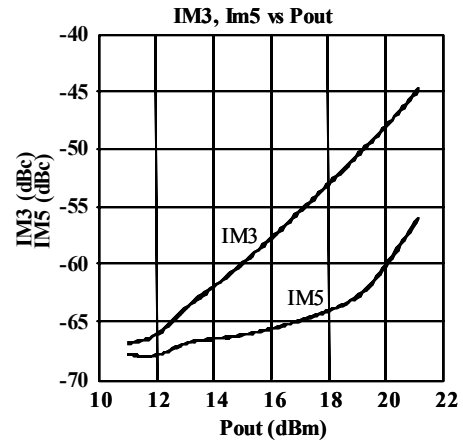
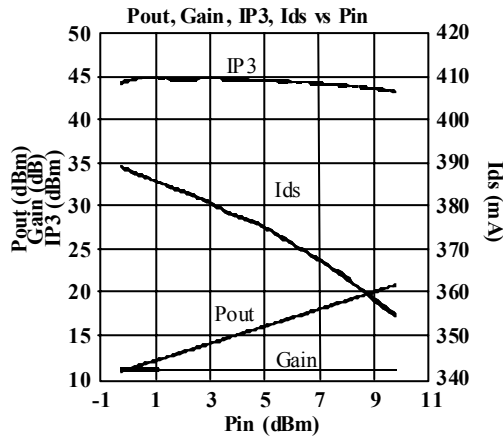

◆ Caution: Power Supply Sequence

For safe operation, electric power should be supplied in following sequence. First, the negative voltage should be applied on the gate, and the voltage should be more negative than the pinch-off voltage when you turn on the power supply. Then, drain bias can be applied. Finally, you can turn on the RF signal.

When turning off the power supply, the sequence should be (1)RF signal (2)Drain (3)Gate.

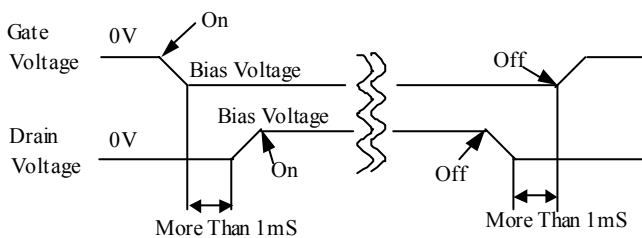

◆ Bias Circuit

[Passive Biasing]

If you use a fixed bias circuit, you sometimes need to control the gate bias to get the same I_{ds} , since the devices have some margin of pinch-off voltage (V_p) variation depending on the wafer lots. If you employ a fixed V_{gs} biasing for your system, you should closely monitor the drain current, particularly when new wafer lots are introduced.

[Active Biasing]

We recommend using an active bias circuit, which can eliminate the influence of V_p variation. An example of an active bias circuit called "current mirror" is shown below. Here, two PNP transistors having the minimum variation of I_{be} characteristics are used. These transistors adjust V_{gs} by changing V_{ds} automatically. It will realize the constant current characteristics, regardless of the temperature.

The circuit should be connected directly in line with where the voltage supplies would be normally connected with the application circuit. Of course a matching circuit is required, but it is not shown in this figure.

[Note]

In the measurements of RF performance (P_{out} vs P_{in} , etc) using the application circuit described before, the active bias circuit herein was not utilized. The application circuits were biased directly from two power supplies.

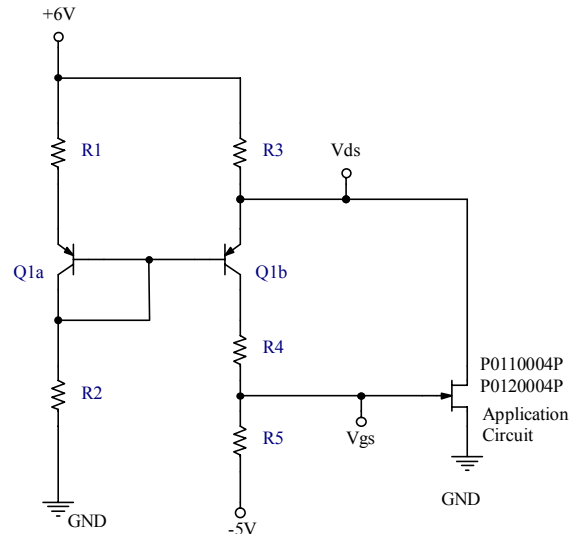

Vds	+5.9V
Ids	400mA
Q1	UMT1N (Rohm)
R1	20Ω 1/10W
R2	1.8kΩ 1/10W
R3	0.15Ω RL series (SUSUMU)
R4	1kΩ 1/10W
R5	1.3kΩ 1/10W

If you used I_{ds} other than 400mA, you can calculate the resistance values as follows:

R4 set to be 1kΩ

I_1 : I_c of Q1a I_2 : I_c of Q1b

V_{be1} : V_{be} of Q1a V_{be2} : V_{be} of Q1b

$$R1 = (+6V - V_{ds} + V_{be2} - V_{be1}) / I_1 = (+6V - V_{ds}) / I_1$$

$$R2 = (V_{ds} - V_{be2}) / I_1$$

$$R3 = (+6V - V_{ds}) / (I_{ds} + I_2)$$

$$R5 = |-5V - V_{gs}| / I_2$$

◆ Attention to Heat Radiation

In the layout design of the printed circuit board (PCB) on which the power FETs are attached, the heat radiation to minimize the device junction temperature should be taken into account, since it significantly affects the MTTF and RF performance. In any environment, the junction temperature should be lower than the absolute maximum rating during the device operation and it is recommended that the thermal design has enough margin.

The junction temperature can be calculated by the following formula.

$$T_{jmax} = (V_{ds} \cdot I_{ds} - P_{out})(R_{th} + R_{board} + R_{hs}) + T_a$$

- P_{out} : Output power
- R_{th} : Thermal resistance between channel and case
- R_{board} : Thermal resistance of PCB
- R_{hs} : Thermal resistance of heat sink
- T_a : Ambient temperature
- T_{jmax} : Maximum junction temperature

Generally, there are two ways of heat radiation. One is the plated thru hole and the other is the heat sink. Key points will be illustrated in each case below. Note that no measure against oscillation is adopted in the figures. In the design of circuit and layout, you should take stabilizing into account if necessary.

[Using Thru Hole]

- Multiple plated thru holes are required directly below the device.
- Place more than 2 machine screws as close to the ground pin (pin 4) as possible. The PCB is screwed on the mounting plate or the heat sink to lower the thermal resistance of the PCB.
- Lay out a large ground pad area with multiple plated thru holes around pin 4 of the device.
- The required matching and feedback circuit described in the application circuit examples should be connected to the device, although it is not shown in the figure below.

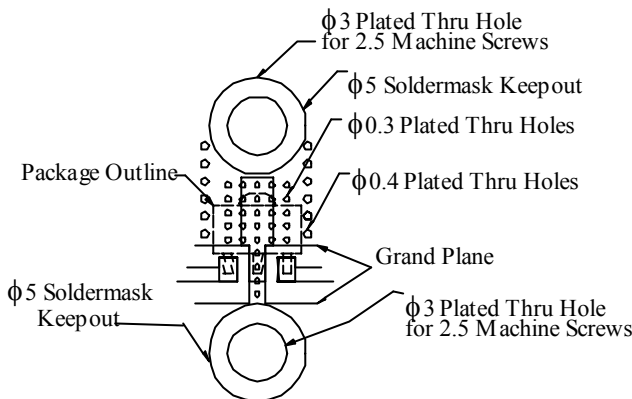

[Using Heat Sink]

If you cannot get the junction temperature lower than the absolute maximum rating only with the plated thru holes, then you need to employ the heat sink. Attaching the heat sink directly under pin 4 of the device improves the thermal resistance between junction and ambient.

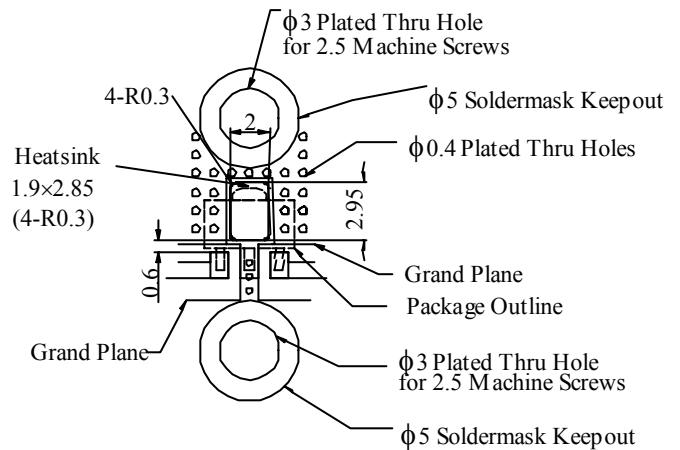

[Note]

- Ground/thermal vias are critical for the proper device performance. Drills of the recommended diameters should be used in the fabrication of vias.
- Add as much copper as possible to inner and outer layers near the part to ensure optimal thermal performance.
- Mounting screws can be added near the part to fasten the board to heat sink. Ensure that the ground/thermal via region contacts the heat sink.
- Do not put solder mask on the backside of the PCB in the region where the board contacts the heat sink.
- RF trace width depends upon the PCB material and construction.
- Use 1 oz. Copper minimum.

◆ Package Drawing

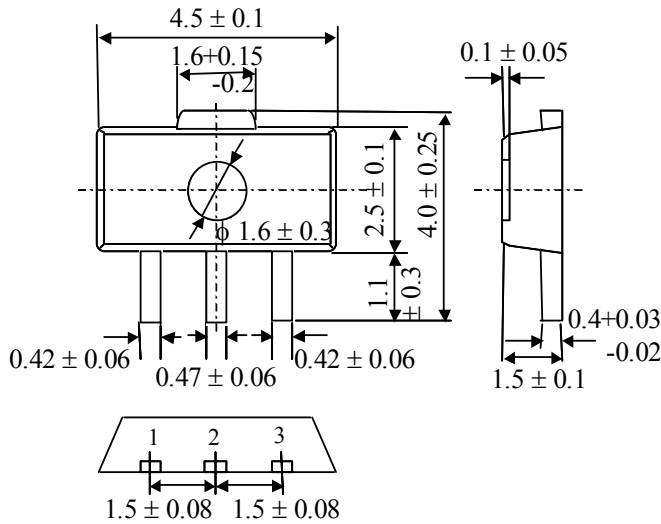

◆ Laser Marking

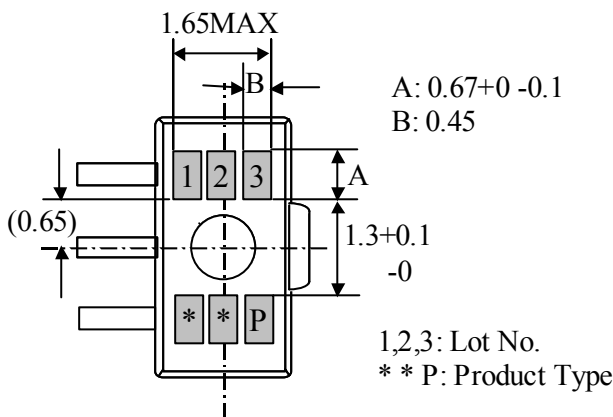

◆ Convection Reflow Profile (Recommended)

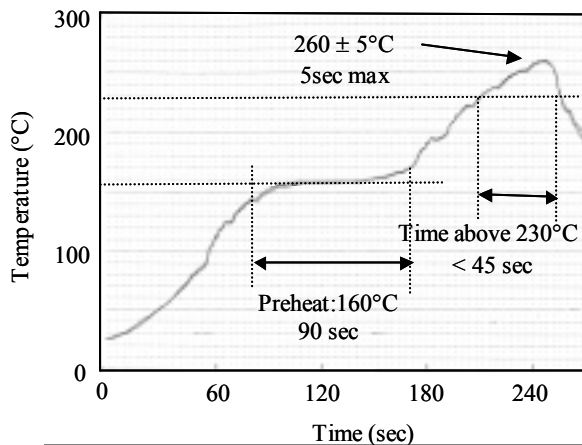

[Note]

The reflow profile is different from the one for Sn-Pb plating.

If you use a soldering iron to attach the devices, please beware of the followings.

- (1) The tip of the iron should be grounded. Or you should use an iron that is electrostatic discharge proof.
- (2) The temperature of the iron tip should be lower than 240°C and the soldering should be completed within 10 seconds.

◆ Attention to ESD

Generally, GaAs devices are very sensitive to electrostatic discharge (ESD). To reduce the ESD damage, please pay attention to the followings. The devices should be stored with the electrodes short-circuited by conductive materials. The workstation and tools should be grounded for safe dissipation of the static charges in the environment. The workpeople are to wear anti-static clothing and wrist straps. For safety reasons, resistance of 10MΩ or so should exist between workpeople and ground.

◆ Attention to Moisture

The moisture sensitivity level (MSL) of P0120004P is 3, which means that the “floor life” is 168 hours below 30°C with relative humidity (Rh) of 60%.

The devices are usually shipped in moisture-resistant alumina-laminated packages. After breaking the packages, they are to be stored under normal temperature and humidity (5-35°C, 45-75%), with no corrosive gases or dust in the environment. Assemble the devices within 168 hours after breaking the package, or you have to bake them at 85°C for 24 hours before assembling.

◆ Reliability and Environmental Issues

The detailed reliability information can be seen in *Reliability and Quality Assurance*, which you can download from our web site.

SEI's Yokohama Works, where the devices are manufactured, has been accredited ISO-14001 since 1999. We control the toxic materials in our products in accordance with PRTR regulation.

◆ Lead and Fluoride

To realize Pb-free products, Sn-Bi is used for the lead frame plating. Any fluoride that has been determined by the Montreal agreement is not used in the products.



P0120004P

1.5W GaAs Power FET (Pb-Free Type)

Technical Note

SUMITOMO ELECTRIC

◆ Caution

GaAs FET chips are used in P0120004P. For safety reasons, you should attend to the following matters:

- (1) Do not put the products in your mouse.
- (2) Do not make the products into gases or powders, by burning, breaking or chemical treatments.

(3) In case you abandon the products, you should obey the related laws and regulations.

◆ Technical Inquiries are Welcome

SEI welcomes technical questions from any customers. The e-mail is GaAsIC-ml@ml.sei.co.jp. You can also contact our regional offices as below.

◆ Worldwide Contacts

[Europe]

Sumitomo Electric Europe Ltd.
220 Centennial Park, Centennial Avenue,
Elstree, Herts. WD6 3SL U.K.
Tel : +44-(0)20-8953-3369, Fax : +44-(0)20-8207-5950
URL : <http://www.sumielectric.com>

[U.S.A.]

Sumitomo Electric U.S.A., Inc.
3235 Kifer Road, Suite 150
Santa Clara, CA 95051-0815 USA
Tel : +1-408-737-8517
Fax : +1-408-734-8881

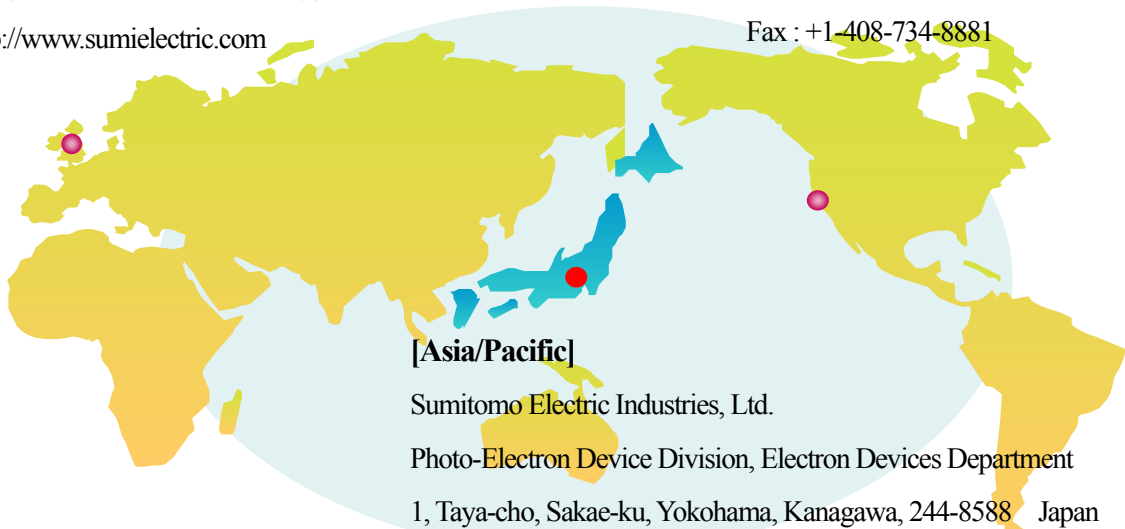

[Asia/Pacific]

Sumitomo Electric Industries, Ltd.
Photo-Electron Device Division, Electron Devices Department
1, Taya-cho, Sakae-ku, Yokohama, Kanagawa, 244-8588 Japan
Tel : +81-(0)45-853-7263, Fax : +81-(0)45-853-1291

URL: <http://www.sei.co.jp/GaAsIC/>

E-mail: GaAsIC-ml@ml.sei.co.jp



P0120003P

800mW GaAs Power FET (Pb-Free Type)

Technical Note

SUMITOMO ELECTRIC

- ◆The information in this document is subject to change without notice. Please refer for the most up-to-date information before you start design using SEI's devices.
- ◆Any part of this document may not be reproduced or copied.
- ◆SEI does not assume any liability for infringement of patents, copyrights or other intellectual property rights of third parties by or arising from the use of SEI's products described in this documents. No license, express, implied or otherwise, is granted under any patents, copyrights or other intellectual property rights of SEI or others.
- ◆Descriptions of circuits and other related information in this document are for illustrative purpose in the examples of the device operation and application. SEI does not assume any responsibility for any losses incurred by customers or third parties arising from the use of the circuits and other related information in this document.
- ◆SEI's semi-conductor device products are designed and manufactured for use in the standard communication equipment. Customers that wish to use these products in applications not intended by SEI must contact SEI' sales representatives in advance.
- ◆Generally, it is impossible to eliminate completely the defects in semi-conductor products, while SEI has been continually improving the quality and reliability of the products. SEI does not assume any responsibility for any losses incurred by customers or third parties by or arising from the use of SEI's semi-conductor products. Customers are to incorporate sufficient safety measures in the design such as redundancy, fire-containment and anti-failure features.