

# Ceramic High Pass Filter

1510 to 5000 MHz

**NEW!**  
**HFCN-1300**



**BLUE CELL™**

CASE STYLE: FV1206

## Maximum Ratings

Operating Temperature	-55°C to 100°C
Storage Temperature	-55°C to 100°C
RF Power Input*	7W max. at 25°C

\*Passband rating, derate linearly to 3W at 100°C ambient.

## Pin Connections

RF IN	1**
RF OUT	3**
GROUND	2,4

\*\* RF IN & RF OUT can be interchanged

## Outline Drawing

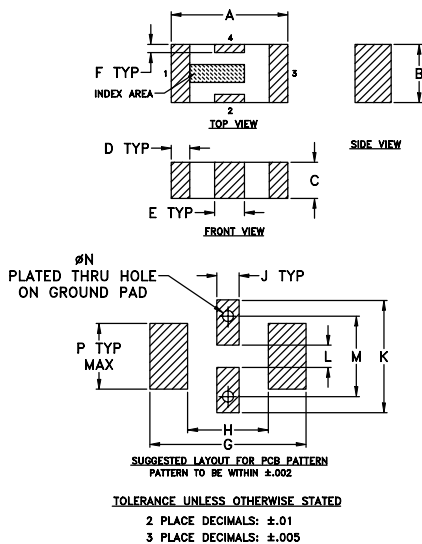

## Outline Dimensions (inch)

A	B	C	D	E	F	G
.126	.063	.037	.024	.032	.009	.169
3.20	1.60	0.94	0.51	0.81	0.23	4.29

H	J	K	L	M	N	P	wt
.087	.024	.122	.024	.087	.012	.071	grams
2.21	0.61	3.10	0.61	2.21	0.30	1.80	.020

**Demo Board MCL P/N: TB-270**  
**Suggested PCB Layout (PL-137)**

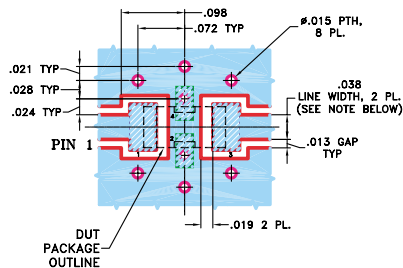

**NOTE:**  
1. TRACE WIDTH IS SHOWN FOR ROGERS RO4350 WITH DIELECTRIC THICKNESS .020" ± .0015". COPPER: 1/2 OZ. EACH SIDE. FOR OTHER MATERIALS TRACE WIDTH MAY NEED TO BE MODIFIED.  
2. BOTTOM SIDE OF THE PCB IS CONTINUOUS GROUND PLANE.

DENOTES PCB COPPER LAYOUT  
 DENOTES COPPER LAND PATTERN FREE OF SOLDERMASK

## Features

- low cost
- small size
- 7 sections
- temperature stable
- excellent power handling, 7W

## Applications

- sub-harmonic rejection
- transmitters/receivers
- lab use

## High Pass Filter Electrical Specifications<sup>1</sup> (T<sub>AMB</sub>=25°C)

MODEL NO.	STOP BAND (MHz)		f <sub>co</sub> , MHz Nom. (loss > 3 dB) Typ.	PASSBAND (MHz)		VSWR Typ. Frequency (MHz) 1.5:1	POWER INPUT (W)	NO. OF SECTIONS
	(loss > 40 dB)	(loss > 20 dB)		(loss < 1.3 dB) Max.	(loss < 2 dB) Typ.			
HFCN-1300	680	930	1300	1510-4000	1400-5000	20:1	1400-4000	7

1. For Applications requiring DC voltage to be applied to the Input or output, use HFCN-1300D (DC Resistance to ground is 100 Mohms min.)

## typical frequency response

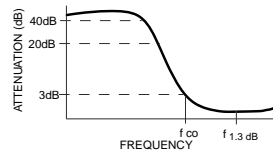

## schematic

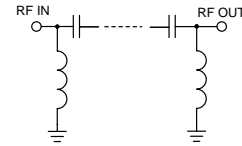

## Typical Performance Data at 25°C

Frequency (MHz)	Insertion Loss (dB)	VSWR (:1)
1.00	89.20	>20
50.00	75.85	>20
690.00	49.92	>20
938.00	27.78	>20
1184.00	9.38	10.43
1305.00	2.72	2.59
1500.00	1.02	1.29
2000.00	0.58	1.21
2500.00	0.61	1.44
3000.00	0.52	1.28
3500.00	0.48	1.15
4000.00	0.64	1.41
5000.00	1.67	2.50
6000.00	3.37	4.38
7000.00	5.35	7.47

