

Features

- ADRO™ amplification technology
- adaptive directional microphone system
- adaptive feedback canceller
- noise management
- available optional turn-key software
- high fidelity audio CODEC
- 20-bit audio precision
- 95dB input dynamic range with HRX™ Headroom Extension
- drives zero-bias 2-terminal receivers
- 4 analog inputs
- 4 fully configurable memories with audible memory change indicator
- 2 memory select pads
- volume control with configurable adjustment range
- 8kHz bandwidth
- optimized programming speed
- thinSTAX® packaging

thinSTAX Packaging

- Hybrid typical dimensions:
0.215 x 0.124 x 0.065in
5.46 x 3.15 x 1.65mm

Description

Advanta™ is Gennum's premium high-end product with ADRO technology from Dynamic Hearing implemented on the Voyageur™ platform. The flexibility and sophistication of ADRO combines with the precision and advanced capabilities of Voyageur to deliver unprecedented sound quality, comfort and audibility to hearing aid wearers.

ADRO is fitted via direct in-situ measures to ensure a fast, customised fitting. ADRO uses statistical analysis and gain customized in 32 independent channels, so that the sound level is always optimized to be within the comfortable dynamic range of the listener.

Advanta's adaptive directional microphone technology provides added benefit in background noise. Advanta automatically changes from directional to omni-directional in different environments as needed. Advanta has an adjustable threshold criterion and becomes omni-directional in wind noise, and in quiet. In the directional mode, the signals from two omni-directional microphones are combined and the null is automatically moved to optimise noise rejection. The adaptive directional microphone features a flat frequency response, so that no additional frequency compensation is required. It is easily configured for different microphone placements, and can be calibrated to match multiple microphones.

The advanced feedback canceller provides increased maximum stable gain. Additionally, it features rapid adjustment for dynamic feedback situations.

Advanta is available with the Configure™ fitting software, so named as it allows the customer to quickly configure the hearing aid. Configure features a stand-alone database supporting multiple sessions, automatic interface detection and an intuitive fitting procedure which achieves fast and accurate fittings. A software interface library for customers wishing to integrate support for Advanta into existing fitting software is also available.

Other configurable options on Advanta include: fixed directional microphone, internal noise reduction with user programmable settings, direct audio input, telecoil input, calibration and test modes supporting standard IEC/ANSI procedures, adjustable input selection, and four listening programs.

Block Diagram

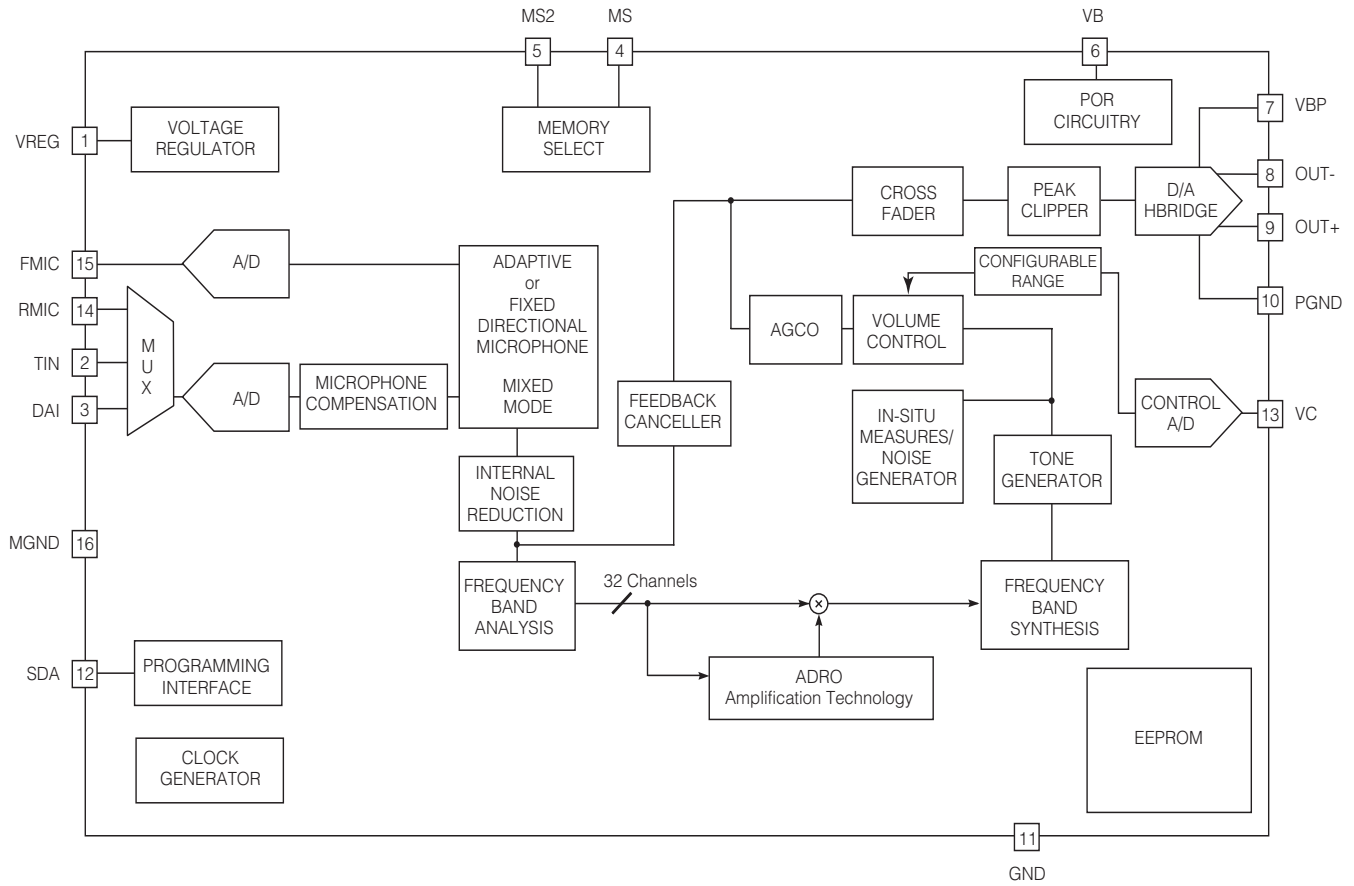

Hybrid block diagram

Contents

Features	1
thinSTAX Packaging	1
Description	1
1. Pad Connection.....	4
2. Absolute Maximum Ratings	4
3. Warnings	4
4. Electrical Characteristics	5
5. Typical Applications	7
6. Advanta Overview	9
7. Functional Block Description.....	9
7.1 ADRO Processing	9
7.2 Adaptive Directional Microphone	10
7.2.1 Threshold Criterion	10
7.3 Noise Reduction	10
7.3.1 Expansion Threshold.....	10
7.3.2 Expansion Ratio.....	10
7.3.3 Time Constants.....	11
7.4 Adaptive Feedback Cancellor	11
7.5 A/D and D/A Converters	12
7.6 HRX Head Room Expander	12
7.7 Volume Control	12
7.8 Memory Select Switches	12
7.8.1 Momentary Switch on MS.....	13
7.8.2 Momentary Switch on MS, Static Switch on MS2 (jump to last memory).....	13
7.8.3 Static Switch on MS and MS2	13
7.8.4 Static Switch on MS, Static Switch on MS2 (jump to last memory).....	14
7.9 Audible Memory Change Indicator	15
7.10 Cross Fader	15
7.11 SDA Communication	15
7.12 Power Management	15
7.13 Power-On/Power-Off Behavior and Low Battery Indicator	16
7.14 Telecoil Path	17
8. Software Support	18
8.1 ADROCOM	18
8.2 Advanta CalConfig	18
8.3 Configure™	18
9. Package Dimensions	19
9.1 Pad Location	20
10. Revision History	21

1. Pad Connection

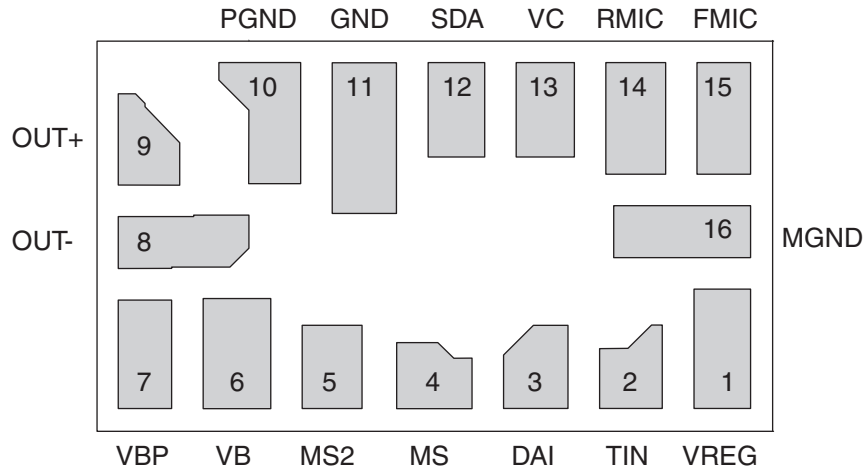

Figure 1-1: Pad Connection

2. Absolute Maximum Ratings

Parameter	Value
Operating Temperature Range	0°C to 40°C
Storage Temperature Range	-20°C to 70°C
Maximum Operating Supply Voltage	1.5VDC
Absolute Maximum Supply Voltage	2VDC

3. Warnings

CAUTION
 LEVEL 3 MOISTURE SENSITIVE DEVICES
 DO NOT OPEN PACKAGES EXCEPT UNDER CONTROLLED CONDITIONS

CAUTION
 ELECTROSTATIC SENSITIVE DEVICES
 DO NOT OPEN PACKAGES OR HANDLE EXCEPT AT A STATIC-FREE WORKSTATION

4. Electrical Characteristics

Table 4-1: Electrical Characteristics

 Conditions: $V_{BAT} = 1.25V$ Temperature = 25°C

Parameter	Symbol	Conditions	Min	Typ	Max	Units
Minimum Operating Supply Voltage	V_{BOFF}	Ramp down	0.93	0.95	0.97	V
Supply Voltage Turn On Threshold	V_{BON}	Ramp up	1.06	1.1	1.16	V
EEPROM Burn Cycles	–	–	100k	–	–	cycles
Current Consumption	–	ADRO-only (single mic)	–	850	–	μA
	–	All features enabled (dual mic)	–	1.1	–	mA
Low Frequency System Bandwidth	–	–	–	125	–	Hz
High Frequency System Bandwidth	–	16kHz sampling rate	–	8	–	kHz
Total Harmonic Distortion	THD	$V_{IN} = -40dBV$	–	–	1	%
THD at Maximum Input	THD_M	$V_{IN} = -15dBV$, HRX - ON	–	–	3	%
Clock Frequency	f_{clk}	–	1.945	2.048	2.151	MHz
Regulator						
Regulator Voltage	V_{REG}	–	0.87	0.90	0.93	V
Input						
Input Referred Noise	IRN	Bandwidth 100Hz - 8KHz	–	-109	-106	dBV
Input Impedance	Z_{IN}	–	–	16	–	$k\Omega$
Anti-aliasing Filter Rejection	–	$f = f_{CLK} - 8kHz$, $V_{IN} = -40dBV$	–	80	–	dB
Maximum Input Level	–	–	–	-15	–	dBV
Input Dynamic Range	–	HRX - ON Bandwidth 100Hz - 8KHz	–	94	–	dB
A/D Dynamic Range	–	Bandwidth 100Hz - 8KHz	–	83	–	dB
Output						
D/A Dynamic Range	–	–	–	88	–	dB
Output Impedance	Z_{OUT}	–	–	–	15	Ω

Table 4-1: Electrical Characteristics (Continued)Conditions: $V_{BAT} = 1.25V$ Temperature = $25^{\circ}C$

Parameter	Symbol	Conditions	Min	Typ	Max	Units
Volume Control						
Volume Control Resistance	R_{VC}	Three-terminal connection	100	–	1000	$k\Omega$
Volume Control Range	ΔA	Adjustable VC range from 0 to +/-18 dB. Supports non-symmetrical ranges.	-18	–	+18	dB
SDA Input						
Logic 0 Voltage	–	–	0	–	0.3	V
Logic 1 Voltage	–	–	1	–	1.3	V
SDA Output						
Standby Pull Up Current	–	–	1.4	2	2.6	μA
Sync Pull Up Current	–	–	450	500	550	μA
Logic 0 Current (Pull Down)	–	–	225	250	275	μA
Logic 1 Current (Pull Up)	–	–	225	250	275	μA
Synchronization Time (Synchronization Pulse Width)	T_{SYNC}	Baud = 0	237	250	263	μs
	T_{SYNC}	Baud = 1	118	125	132	μs
	T_{SYNC}	Baud = 2	59	62.5	66	μs
	T_{SYNC}	Baud = 3	29.76	31.25	32.81	μs
	T_{SYNC}	Baud = 4	14.88	15.63	16.41	μs
	T_{SYNC}	Baud = 5	7.44	7.81	8.20	μs
	T_{SYNC}	Baud = 6	3.72	3.91	4.10	μs
	T_{SYNC}	Baud = 7	1.86	1.95	2.05	μs
MS and MS2 Inputs						
Pull Down / Up Resistance	–	–	–	1	–	$M\Omega$
Logic 1 Voltage	–	–	V_{REG}	–	V_B	V
Rising Edge Threshold	–	–	0.5	0.69	0.9	V
Falling Edge Threshold	–	–	0.25	0.45	0.5	V
Hysteresis	–	–	0.1	0.24	0.4	V

5. Typical Applications

All resistors in ohms, all capacitors in farads unless otherwise stated.

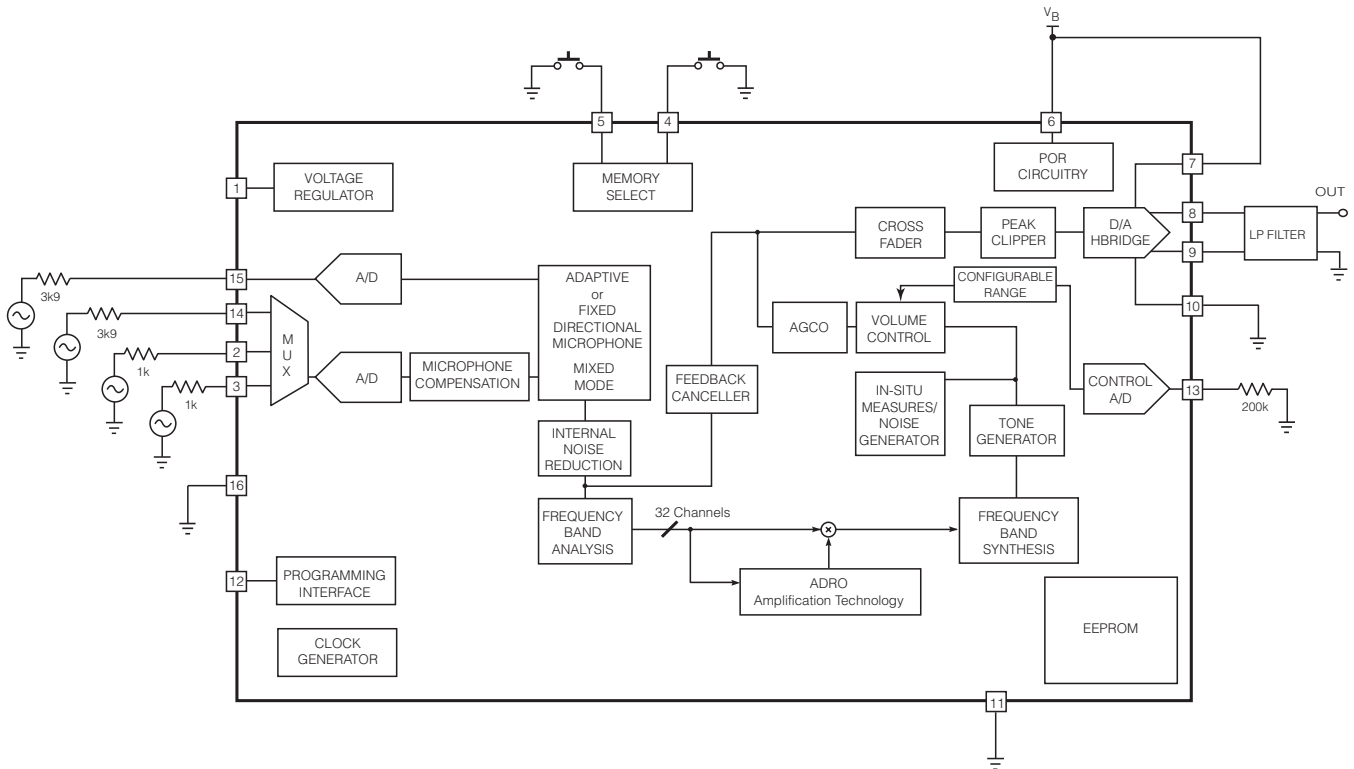

Figure 5-1: Test Circuit

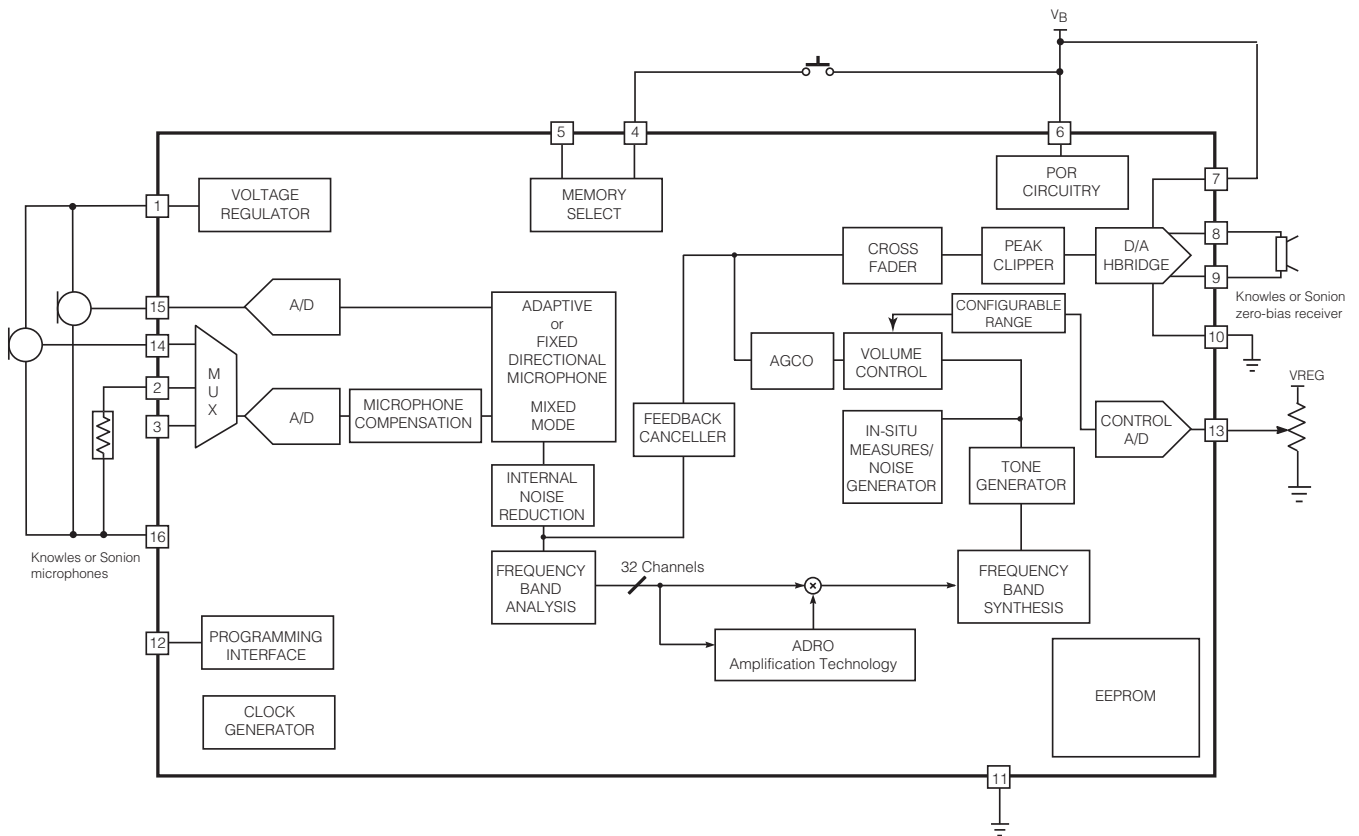

Figure 5-2: Typical Application Circuit

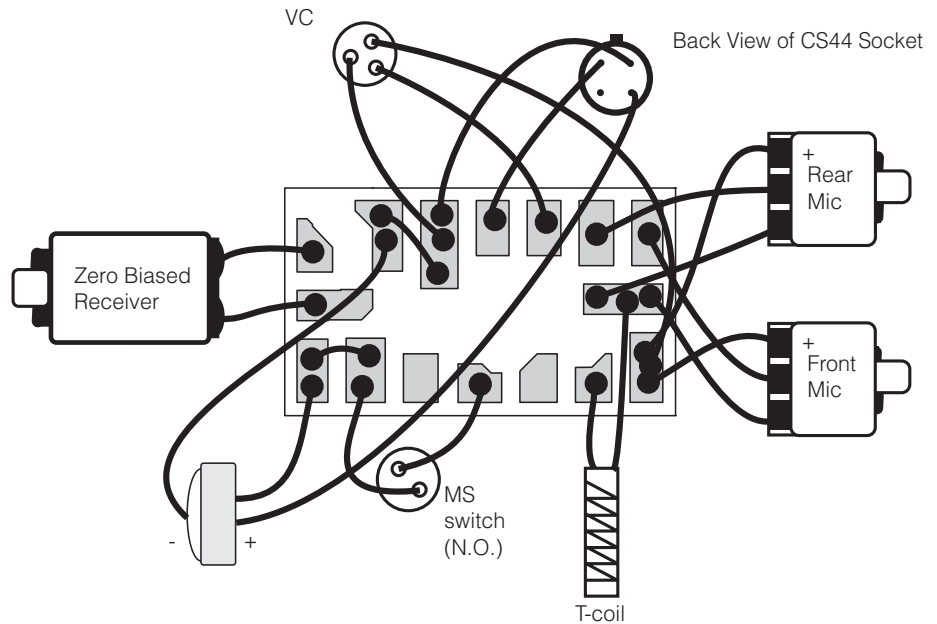

Figure 5-3: Typical Hearing Instrument Assembly Diagram

6. Advanta Overview

Advanta is a DSP system with adaptive algorithms and the ADRO sound processing methodology implemented on the Voyageur hardware platform. This hardware platform is a combination of a DSP core and a high fidelity audio CODEC. As well, thinSTAX packaging provides easy integration into a wide range of applications from CIC to BTE.

The CODEC converts analog audio into digital samples for the DSP, and outputs processed samples to the receiver. The CODEC also implements cross fading between audio paths. The DSP core implements the adaptive algorithms, ADRO processing, volume control, and tone generation. The adaptive algorithms include an adaptive directional microphone and feedback cancellation. Internal noise reduction is also included. The processing is based on ADRO targets, which eliminates the need for EQ filters or wide band gain settings.

7. Functional Block Description

7.1 ADRO Processing

ADRO uses advanced statistical analysis and fuzzy logic control in 32 narrow frequency channels to achieve a natural sound, with maximum listening comfort and audibility in all environments. Instead of compressing the signal, the most informative part of the dynamic range is selected and presented linearly in every one of the 32 channels. The linear processing of ADRO results in a natural sound that is preferred by first-time and experienced hearing aid users alike.

ADRO is easy to fit and flexible enough to fit any hearing loss taking individual preferences into account. There is no need to consider compression ratios, knee-points, or other complex settings – intuitive adjustments fine tune ADRO to overcome any hearing problem. Once fitted well in one environment, ADRO automatically adjusts to any other. Clinical trials show substantial benefits in background noise, with loud, average and soft speech in quiet and for a wide variety of environmental sounds.*Blamey PJ, Martin LFA & Fiket HJ (2004). A digital processing strategy to optimize hearing aid outputs directly. J Am Acad Audiol. (2004 Nov–Dec; 15(10):716–28)

7.2 Adaptive Directional Microphone

Adaptive directional microphones offer flexibility over fixed directional microphones as noise from any direction can be optimally rejected. The architecture of this particular adaptive directional microphone combines the input from two microphones to achieve the desired response. The inherently flat frequency response of the adaptive directional microphone eliminates the need for a separate frequency compensation algorithm.

An adjustable threshold criterion also allows the Adaptive Directional Microphone to automatically adapt to an omni-directional response when the environment is relatively quiet. In situations where a directional response is noisy (e.g. wind) an omni-directional response is also automatically used. In the case of a diffuse sound field, the adaptive directional microphone adapts to a super-cardioid polar pattern, which is optimal for this situation.

7.2.1 Threshold Criterion

The recommended threshold for the adaptive directional microphone is 65-70dBSPL. This threshold ensures that in quiet environments an omni-directional response is adopted, and that in a moderately noisy environment the appropriate directional response is used.

7.3 Noise Reduction

The internal noise reduction system is a single-channel expansion scheme operating to reduce the broad-band noise generated internally in the hearing aid – particularly in the microphone.

The intensity of both the noise and signal after the front microphone pre-amp is shaped with an approximately A-weighted filter designed to more accurately reflect the sensitivity of the human ear. This weighting means that the INR threshold is at a fairly constant sensation level across frequency, as opposed to a constant intensity. The aggressiveness of the noise reduction algorithm is adjustable.

7.3.1 Expansion Threshold

Test box measures show that the speech intelligibility index of soft speech (55dBSPL LTASS) is not compromised with an expansion threshold of 50 - 55 dBSPL.

The recommended expansion threshold setting for the fixed directional microphone is 50 - 55 dBSPL .

7.3.2 Expansion Ratio

The recommended expansion ratio is 0.7 to minimize audible effect when the hearing aid moves in and out of expansion. Ratios less than 0.6 are not recommended.

7.3.3 Time Constants

The preconfigured attack and release times are 200ms and 20ms respectively for two main reasons:

1. To ensure that the noise reduction system is not activated during softer phonemes in speech (slower expansion attack time) and that the system quickly responds to the onset of speech (faster expansion release time). The typical duration of phonemic gaps between syllables in speech is about 150ms, so the expansion attack time should be longer than this to avoid distorting the speech envelope.
2. Slow time constants are in keeping with ADRO processing and are optimized to preserve the sound quality of speech.

7.4 Adaptive Feedback Canceller

Advanta's feedback canceller reduces acoustic feedback by forming an estimate of the hearing aid feedback signal and then subtracting this estimate from the hearing aid input. Therefore, the forward path of the hearing aid is not affected. Unlike adaptive notch filter approaches, Advanta's feedback canceller does not reduce the hearing aid's gain.

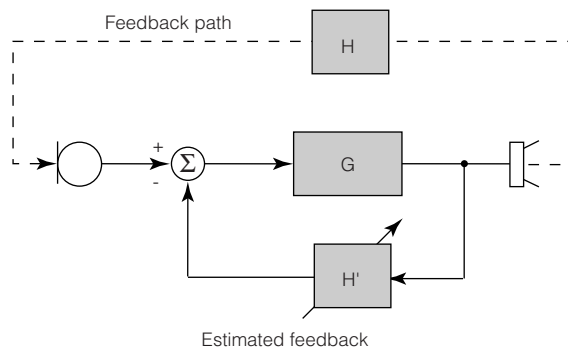

Figure 7-1: Adaptive Feedback Canceller block diagram

7.5 A/D and D/A Converters

The system's two A/D converters are 2nd-order sigma-delta modulators, which operate at a 2.048MHz sample rate. The system's two audio inputs are pre-conditioned with antialias filtering and programmable gain pre-amplifiers. These analog outputs are over sampled and modulated to produce two, 1-bit pulse density modulated (PDM) data streams. The digital PDM data is then decimated down to pulse-code modulated (PCM) digital words at the system sampling rate of 16kHz.

The D/A is comprised of a digital, 3rd-order sigma-delta modulator and an H-bridge. The modulator accepts PCM audio data from the DSP path and converts it into a 32-times over-sampled, 1-bit PDM data stream, which is then supplied to the H-bridge. The H-bridge is a specialized CMOS output driver used to convert the 1-bit data stream into a differential output voltage waveform suitable for driving low-impedance zero-biased hearing aid receivers.

7.6 HRX Head Room Expander

Advanta has an enhanced Head Room Expander (HRX) circuit, which increases the input dynamic range of Advanta without any audible artifacts. This is accomplished by dynamically adjusting the pre-amplifier's gain and the post-A/D attenuation depending on the input level.

7.7 Volume Control

An external 3-terminal volume control can be connected to Advanta. The volume control range is adjustable from 0dB to +/-18dB, with support for non-symmetrical configurations (e.g. from -5dB to +10dB).

7.8 Memory Select Switches

There are two, two-pole Memory Select switches available on Advanta, which allows the user significant flexibility in switching between configurations. These switches may be either momentary or static and are configurable to be either pull-up or pull-down.

Up to four user memories can be configured on Advanta.

7.8.1 Momentary Switch on MS

This mode uses a single momentary switch on MS (Pin 4) to change memories. Using this mode causes the part to start in Memory A and whenever the button is pressed the next valid memory is loaded. When the user is in the last valid memory, a button press causes memory A to be loaded.

Examples

If 4 valid memories ABCDABCD...

If 3 valid memories ABCABCA...

If 2 valid memories ABABA...

If 1 valid memory AAA...

7.8.2 Momentary Switch on MS, Static Switch on MS2 (jump to last memory)

This mode uses a static switch on MS2 (Pin 5) and a momentary switch on MS (Pin 4) to change memories. If the static switch is OPEN, the part starts in memory A and it behaves like momentary with the exception that memory D is not used. If the static switch on MS2 is set to HIGH, the part will automatically jump to memory D (this happens on start-up or during normal operation). In this setup, the momentary switch's state is ignored, preventing memory select beeps from occurring. When MS2 is set to OPEN, the part loads in the last selected memory. If required, a memory other than D can be used as the jump memory (including one accessible by MS).

Examples

If MS2 = OPEN and there are 4 valid memories: ABCABCA...

If MS2 = HIGH: D...

7.8.3 Static Switch on MS and MS2

This mode uses two static switches to change memories.

[Table 7-1](#) describes which memory is selected depending on the state of the switches.

In this mode it is possible to jump from any memory to any other memory simply by changing the state of both switches. If both switches are changed simultaneously then the transition is smooth, otherwise, if one switch is changed and then the other, the part transitions to an intermediate memory before reaching the final memory.

The part starts in whatever memory the switches are selected. If a memory is invalid the part defaults to memory A.

Table 7-1: Memory selected in Static Switch on MS and MS2 mode

MS	MS2	Memory
OPEN	OPEN	A
HIGH	OPEN	B (if valid, otherwise A)
OPEN	HIGH	C (if valid, otherwise A)
HIGH	HIGH	D (if valid, otherwise A)

7.8.4 Static Switch on MS, Static Switch on MS2 (jump to last memory)

This mode uses two static switches to change memories. Unlike in the previous example, this mode switches to the memory D when the static switch on MS2 is HIGH. This means that this mode uses a maximum of three memories (even if four valid memories are programmed). [Table 7-2](#) describes which memory is selected depending on the state of the switches.

Table 7-2: Memory selected in Static Switch on MS, Static Switch on MS2 (jump to last memory) mode

MS	MS2	Memory
OPEN	OPEN	A
HIGH	OPEN	B (if valid, otherwise A)
OPEN	HIGH	D
HIGH	HIGH	D

In this mode it is possible to jump from any memory to any other memory simply by changing the state of both switches. If both switches are changed simultaneously then the transition is smooth, otherwise, if one switch is changed and then the other, the part transitions to an intermediate memory before reaching the final memory.

When MS2 is set HIGH, the state of the switch on MS is ignored. This prevents memory select beeps from occurring when switching MS when MS2 is HIGH.

The part starts in whatever memory the switches are selected. If a memory is invalid, the part defaults to memory A.

If required, a memory other than D can be used as the jump memory (including one accessible via MS).

7.9 Audible Memory Change Indicator

The length of memory indicator beeps as well as the beep mode (single beep, multi-beep or beeps disabled) are configurable. In addition, each memory can have a different frequency and beep amplitude. Beeps can be non-masking (they do not block the audio path), or masking (the audio path is disabled during beeps).

7.10 Cross Fader

To minimize potential loud transients when switching between memories, Advanta uses a cross fader block. When the memory is changed, the audio signal is faded out, and after switching to the next memory, the audio signal is faded back in. The cross fader is also used during SDA programming.

7.11 SDA Communication

Advanta is programmed via the SDA pin using industry standard programming boxes. During parameter changes the main audio signal path of the hybrid is temporarily muted using the cross fader to avoid the generation of disturbing audio transients. Once the changes are complete, the main audio path is reactivated.

Any changes made during programming are lost at power-off unless they are explicitly burned to EEPROM memory.

7.12 Power Management

Advanta was designed to accommodate high power applications. AC ripple on the supply can cause instantaneous reduction of the battery's voltage, potentially disrupting the circuit's function. Advanta hybrids have a separate power supply and ground connections for the output stage. This allows hearing instrument designers to accommodate external RC filters in order to minimize any AC ripple from the supply line. Reducing this AC ripple greatly improves the stability of the circuit and prevents unwanted reset of the circuit caused by spikes on the supply line. For more information on properly designing a filter to reduce supply ripple, please refer to information note Using the GB3211 PARAGON Digital in High Power Applications Initial Design Tips, document #24561.

7.13 Power-On/Power-Off Behavior and Low Battery Indicator

During power-on, the Advanta hybrid is held in a reset state until the supply voltage (V_b) reaches a turn-on threshold. A small portion of the hybrid's internal control logic turns on and monitors the voltage to determine if the supply is stable. Once the supply is stable, the entire hybrid is activated and loads its configuration. Finally, the audio output turns on by smoothly transitioning to the expected output level.

During normal operation, when a low battery condition (below low battery threshold) is detected, the Advanta hybrid sends out a series of beeps (of configurable length and length) to indicate that the battery is low. This will repeat at a regular interval (configurable from 10 seconds to 10 hours) until the device reaches the turn-off threshold.

The low battery threshold is configurable from between 1.0V and 1.2V in 10mV increments.

If V_b drops below the turn-off threshold then the Advanta hybrid is returned to its reset state and the audio output is muted. After a reset due to a low battery or a sudden supply transient, the recovery behavior of Venture is determined by the selectable reset mode through the Calconfig application.

There are four selectable reset modes as follows:

1. Shallow-reset mode, allows the Advanta hybrid to immediately restart when the supply voltage rises above the turn-ON threshold, after a low battery shutdown or transient shutdown. The device restarts in the memory that was last active when the shut down occurred. In summary, the device functions until the supply voltage drops below the turn-OFF threshold, and recovers when the device rises above the turn-ON threshold again.
2. Deep-reset mode, does not allow the Advanta hybrid to restart after a low battery shutdown or transient shutdown. Once a shut down occurs (i.e. once the supply voltage drops below the turn-OFF threshold), the device remains off until the supply voltage drops below approximately 0.3V and subsequently rises above the turn-ON threshold. In order for the supply to drop below 0.3V, the battery should be disconnected. Upon reconnecting the battery (preferably a new battery) the supply voltage rises above the turn-ON threshold, and subject to the supply being stable, the device restarts.
3. Mixed mode, is a combination of modes 1 and 2. The device starts up in shallow-reset mode initially, and then changes over to deep reset mode after five minutes.

4. Transient reboot mode (recommended), is a more advanced combination of modes 1 and 2, plus some additional intelligence. The device starts up in shallow-reset mode initially, so that after a low battery shutdown or transient shutdown, the device immediately restarts when the supply voltage rises above the turn-ON threshold. Once the device restarts, deep-reset mode is applied and the device operates in the memory that was last active when the shut down occurred. Additionally, the maximum output level is reduced through a 2 dB reduction of the AGCo and peak clipper. This operating condition is defined as transient reboot mode. The device operates in transient reboot mode (meaning deep-reset mode and maximum output reduction are applied) while monitoring the supply voltage. If the supply voltage remains above the turn-on threshold for at least 30 seconds, the device is allowed to exit transient reboot mode. The device returns to mode and the maximum output is restored.

Generally, any low battery shutdown or transient shutdown that occurs while in shallow-reset mode (or while in the shallow-reset mode component of mixed mode or transient reboot mode) results in the Advanta hybrid restarting into the memory that was last active when the shut down occurred. The Advanta hybrid has this memory restart capability for up to three memories. A restart in any memory beyond the first three memories causes the device to restart in the initial memory, similar to the behavior when a battery is first connected. The transient reboot mode described above also applies to up to three memories. Any additional memories use the shallow-reset mode behaviour, and restarts in the initial memory after a shutdown.

7.14 Telecoil Path

The telecoil input is calibrated during the Cal/Config process. To compensate for the telecoil/microphone gain mismatch, the telecoil gain is adjusted to match the microphone gain.

8. Software Support

8.1 ADROCOM

The ADROCOM library provides a simple application programmer's interface for controlling and programming Advanta with proprietary fitting software. The ADROCOM library is a win32 dynamic link library (DLL). The ADROCOM library provides the functionality required to measure audio levels through the hearing aid, and fine-tune the hearing aid fitting. This library also provides a communications interface to the hearing aid to facilitate lower level functions such as connection, device verification, reading and writing to both volatile and non-volatile memory, and being able to stop, start and mute the hearing aid during a fitting session.

8.2 Advanta CalConfig

ADRO algorithm requires calibration of the Advanta hearing instrument before using it with any fitting software. The calibration will adjust the gain and the maximum output level of the instrument so the gain and the maximum output frequency response curves are flat, within specified tolerance, across the frequency spectrum. The calibration is done by Gennum's Advanta CalConfig program.

For more information on Advanta CalConfig Program refer to "Getting Started with Advanta Digital" information note, document 36478.

8.3 Configure™

The Configure fitting software is a a turn-key ADRO fitting solution for Advanta. Configure uses the ADROCOM library to interface with the hearing aid and provide initial fitting predictions.

Configure features a stand-alone database, which stores each client's demographic details, all fitting details and enables access to past fitting sessions.

Configure guides the clinician through an intuitive fitting procedure which achieves fast and effective fittings in as few as four steps; balancing comfort levels, adjusting the volume of the hearing aid, fine-tuning the hearing aid, and programming.

Three programs are saved to the hearing aid when using Configure. The clinician is able to select the microphone configuration in each memory, as well the settings of feedback cancellation and internal noise reduction. Fine-tuning adjustments are always made to the first program and are automatically incorporated into the second and third program.

9. Package Dimensions

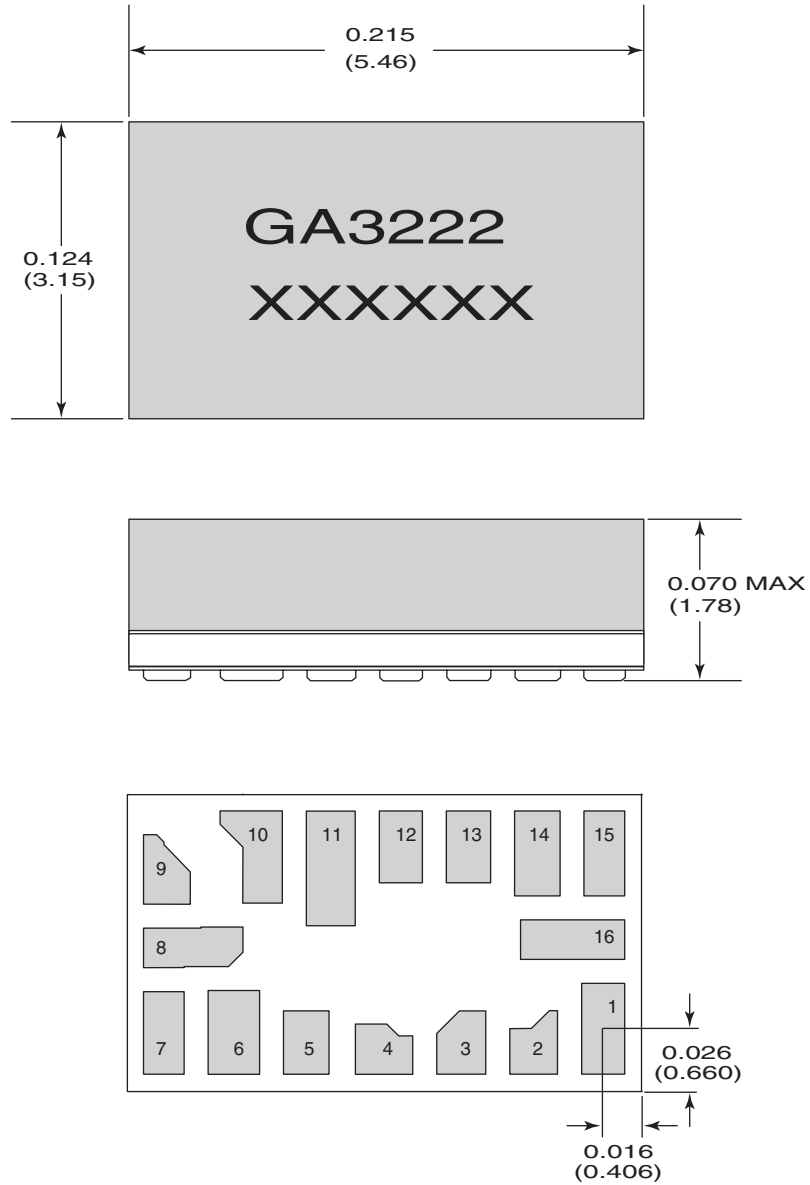

Dimension units are in inches.
 Dimensions in parentheses are in millimetres, converted from inches and include minor rounding errors.
 1.0000 inches = 25.400mm
 Dimension tolerances: ±0.005 (±0.13) unless otherwise stated.
 Work order number: XXXXXX
 This Hybrid is designed for either point-to-point manual soldering or for reflow according to Gennum's reflow process (Information Note 521-45).

Figure 9-1: Package dimensions

9.1 Pad Location

Pad No.	Pad Position		Pad Dimensions	
	X	Y	Xdim (MIL)	Ydim (MIL)
1	0	0	18	38
2	-29	-5.75	20	26.5
3	-59.25	-5.75	20.5	26.5
4	-91.5	-8.5	24	21
5	-124	-5.75	19	26.5
6	-154.25	-1.75	21.5	34.5
7	-183.5	-1.75	17	34.5
8	-171.25	33.75	41.5	16.5
9	-182.25	66.5	19.5	29
10	-147	71.5	26	39
11	-113.75	66.5	20.5	49
12	-84.5	76	18	30
13	-56.25	76	18.5	30
14	-27.25	73.25	18.5	35.5
15	0.5	73.25	17	35.5
16	-12.75	37.25	43.5	16.5
	X	Y	Xdim (mm)	Ydim (mm)
1	0	0	0.457	0.965
2	-0.737	-0.146	0.508	0.673
3	-1.505	-0.146	0.521	0.673
4	-2.324	-0.216	0.610	0.533
5	-3.150	-0.146	0.483	0.673
6	-3.918	-0.044	0.546	0.876
7	-4.661	-0.044	0.432	0.876
8	-4.350	0.857	1.054	0.419
9	-4.629	1.689	0.495	0.737
10	-3.734	1.816	0.660	0.991
11	-2.889	1.689	0.521	1.245
12	-2.146	1.930	0.457	0.762
13	-1.429	1.930	0.470	0.762
14	-0.692	1.861	0.470	0.902
15	0.013	2.007	0.432	0.902
16	-0.324	0.946	1.105	0.419

10. Revision History

Version	ECR	Date	Changes and / or Modifications
A	136253	March 2005	New document.
B	137260	October 2005	Updates.
0	138403	February 2006	Update to Preliminary Data Sheet

DOCUMENT IDENTIFICATION
PRELIMINARY DATA SHEET

The product is in a preproduction phase and specifications are subject to change without notice.

GENNUM CORPORATION

Mailing Address: P.O. Box 489, Stn. A, Burlington, Ontario, Canada L7R 3Y3
Shipping Address: 970 Fraser Drive, Burlington, Ontario, Canada L7L 5P5
Tel. +1 (905) 632-2996 Fax. +1 (905) 632-5946

GENNUM JAPAN CORPORATION

Shinjuku Green Tower Building 27F, 6-14-1, Nishi Shinjuku, Shinjuku-ku, Tokyo, 160-0023 Japan
Tel. +81 (03) 3349-5501, Fax. +81 (03) 3349-5505

GENNUM UK LIMITED

25 Long Garden Walk, Farnham, Surrey, England GU9 7HX
Tel. +44 (0)1252 747 000 Fax +44 (0)1252 726 523

Gennum Corporation assumes no liability for any errors or omissions in this document, or for the use of the circuits or devices described herein. The sale of the circuit or device described herein does not imply any patent license, and Gennum makes no representation that the circuit or device is free from patent infringement.

GENNUM and the G logo are registered trademarks of Gennum Corporation.

ADRO™ and Configure™ are trademarks of Dynamic Hearing Pty Ltd.

© Copyright 2005 Gennum Corporation. All rights reserved. Printed in Canada.

www.gennum.com