

MIP704

Silicon MOS IC

■ Features

- 3-pin intelligent power device
- Five protective functions (over-current, over-voltage, short circuit load, over heat, ESD) are integrated
- Acceptable both AC and DC power supply

■ Applications

- For automotive electric equipment

■ Absolute Maximum Ratings (Ta = 25°C)

Parameter	Symbol	Ratings	Unit
Drain to Source voltage	V_{DS}	60	V
Output peak current	I_{OP}	± 5	A
Output current	I_O	-1 to 2* ¹	A
Input voltage	V_{IN}	-0.5 to 6	V
Input current	I_{IN}	± 10	mA
Drain clamp energy	EAS	55* ²	mJ
Allowable power dissipation	P_D	1* ³	W
Operating ambient temperature	T_{opr}	-40 to +85	°C
Channel temperature	T_{ch}	150	°C
Storage temperature	T_{stg}	-55 to +150	°C

*1 Maximum load current, not the average current.

*2 L = 10mH, $I_L = 3.32A$, $V_{DD} = 30V$, 1pulse, $T_C = 85^\circ C$

*3 Mounting on the PCB (Glass epoxy board, the size of 100mm × 100mm). (Ta = 25°C)

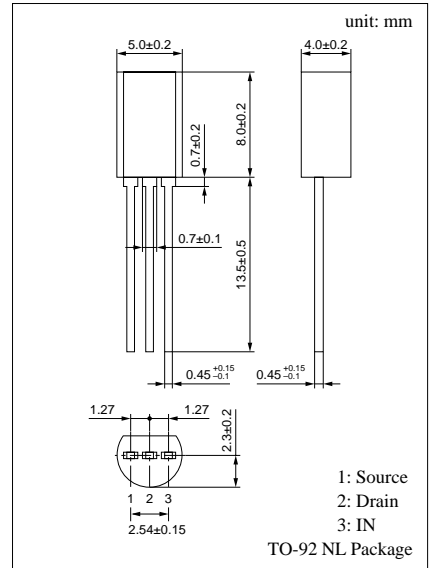

■ Block Diagram

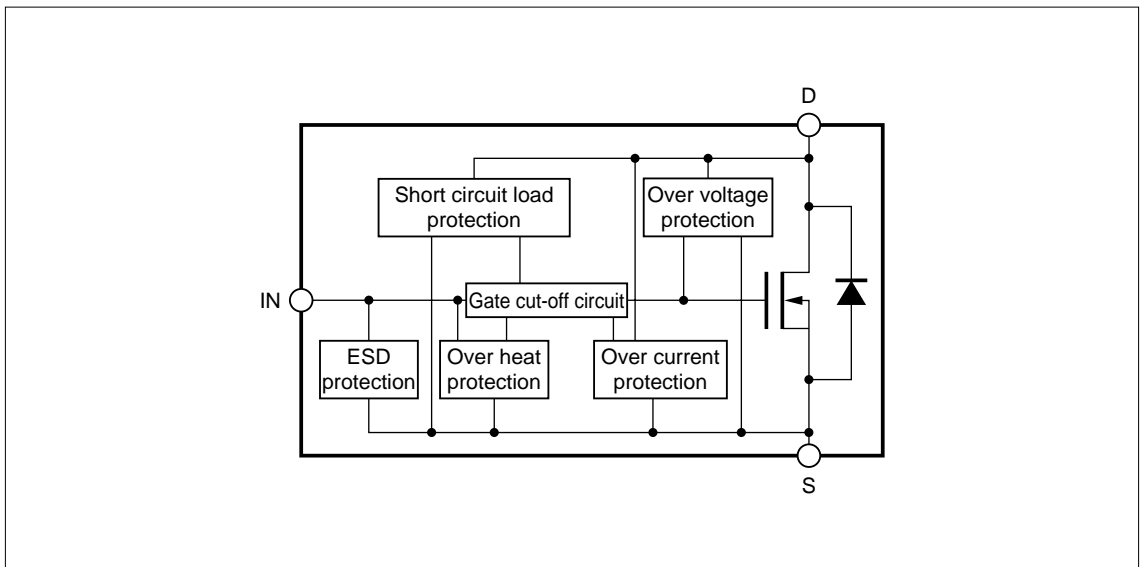

■ Electrical Characteristics ($T_C = 25 \pm 2^\circ\text{C}$)

Parameter	Symbol	Conditions	min	typ	max	Unit
Drain to Source ON-resistance	$R_{DS(on)}$	$V_{IN} = 5V, I_{DS} = 1.5A$		0.38	0.5	Ω
Drain to Source ON-voltage	$V_{DS(on)}$	$V_{IN} = 5V, I_{DS} = 1.5A$		0.57	0.75	V
Drain clamp voltage	$V_{DS(CLIP)}$	$V_{IN} = 0, I_{DS} = 3mA$	60	72		V
Drain OFF current (1)	$I_{DS(off)1}$	$V_{IN} = 0, V_{DS} = 12V$		50	80	μA
Drain OFF current (2)	$I_{DS(off)2}$	$V_{IN} = 0, V_{DS} = 16V$		65	140	μA
Input voltage (High)	$V_{IN(H)}$	$I_{DS} = 2A$	4			V
Input voltage (Low)	$V_{IN(L)}$	$I_{DS} = 1mA$			0.8	V
Input current	$I_{IN(on)}$	$V_{IN} = 5V, V_{DS} = 0$		0.15	0.5	mA
Over current protection limit	I_{OCP}	$V_{IN} = 5V, V_{DS} = 3V$	3.8	5		A
Short circuit load protection limit	$V_{DS(SHT)}$	$V_{IN} = 5V$	3	4		V

Note: The oscillation of the output current is caused when the drain voltage exceeds the short circuit load detection voltage under the ON state of output.

■ Operating condition

Parameter	Symbol	min	typ	max	Unit
Operating supply voltage	V_{DD}			40	V

■ Electrical Characteristics ($T_C = 25 \pm 2^\circ\text{C}$)

Parameter	Symbol	Conditions	min	typ	max	Unit
Over heat protection temperature	T_{SHD}	$V_{IN} = 5V$	170	205	240	$^\circ\text{C}$
Turn on delay time	$t_{d(on)}$	$V_{IN} = 5V, I_{DS} = 1.5A$		3		μs
Rise time	t_r			18		μs
Turn off delay time	$t_{d(off)}$	$V_{DD} = 12V, R_L = 8.2\Omega$		12		μs
Fall time	t_f				20	μs

Note 1: The above values of characteristics are not guaranteed values and are only references for designing.

Note 2: If the chip temperature exceeds the "Over Heat Protection Temperature", output current is shut down.