

9011, 9012 & 9091 Miniature SIP Relays

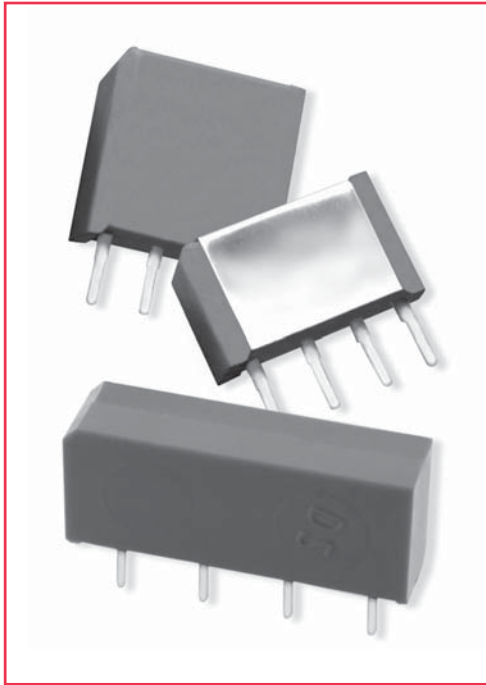

Miniature Molded SIP Reed Relays

The 9012 package dimensions are 47% smaller than standard 9000 SIPs, yet the relay retains the 10W switch ratings of its larger counterparts. The 9011 package dimensions is 65% smaller than the standard 9000 SIPs and incorporates the RI-70 switch rated at 3W. The 9091 is a compact version of the 9001 while using 40% less board space. These miniature SIP relays are ideal for use in ATE applications and other high reliability test, measurement and telecommunications applications where high board density and long life are key requirements.

Series Features

- ◆ 9012 is the smallest 10W SIP relay (.400" x .150" x .400")
- ◆ 9011 is the smallest 3W SIP relay (.400" x .150" x .265")
- ◆ 9091 is a 10W SIP relay measuring (.600" x .150" x .275")
- ◆ Magnetic shielding reduces interaction
- ◆ Optional coil suppression diode protects coil drive circuits
- ◆ UL File # E67117
- ◆ High insulation resistance $10^{12} \Omega$ minimum. ($10^{13} \Omega$ typical)
- ◆ High speed switching
- ◆ Molded thermoset body on integral lead frame design
- ◆ High reliability, hermetically sealed contacts for long life

Model 9011

Dimensions in Inches (Millimeters)

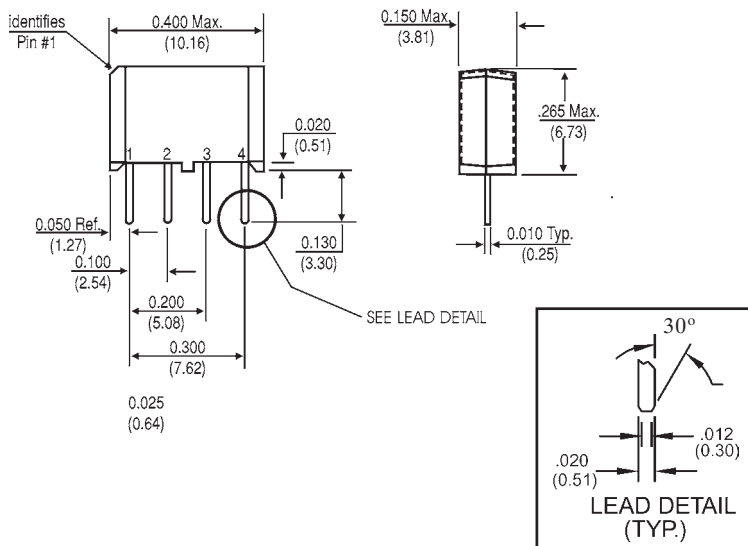

Model 9012

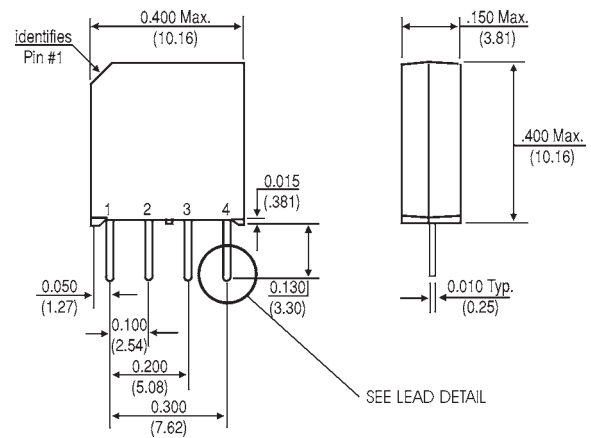

Model 9091

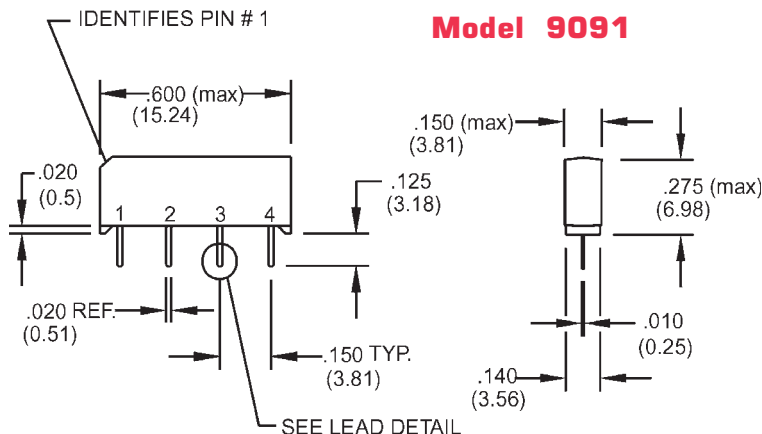

Ordering Information

Part Number	90XX-XX-1X	General Options
Model Number	9011 9012 9091	0 = No Diode 1 = Diode
Coil Voltage	05 = 5 volts 12 = 12 volts	
Magnetic Shield	(Optional on Model 9091, Std. on 9011 & 9012) 0 = No Shield 1 = Mag Shield (External 9011) Shield (Internal 9012, 9091)	

9011, 9012 & 9091 Miniature SIP Relays

Model Number			9011 ^{2,4} (3 Watt) 4 Pin SIP	9012 ^{2,4} (10 Watt) 4 Pin SIP	9091 ^{2,4} (10 Watt) 4 Pin SIP
Parameters	Test Conditions	Units			
COIL SPECS.					
Nom. Coil Voltage		VDC	5 12	5 12	5 12
Max. Coil Voltage		VDC	6.5 15.0	6.5 15.0	6.5 15.0
Coil Resistance	+/- 10%, 25° C	Ω	500 750	500 750	500 1000
Operate Voltage	Must Operate by	VDC - Max.	3.75 9.0	3.75 9.0	3.75 9.0
Release Voltage	Must Release by	VDC - Min.	0.4 1.0	0.4 1.0	0.4 1.0
CONTACT RATINGS					
Switching Voltage	Max DC/Peak AC Resist.	Volts	100	200	200
Switching Current	Max DC/Peak AC Resist.	Amps	0.250	0.5	0.5
Carry Current	Max DC/Peak AC Resist.	Amps	0.5	1.5	1.5
Contact Rating	Max DC/Peak AC Resist.	Watts	3	10	10
Life Expectancy-Typical ¹	Signal Level 1.0V, 10mA	x 10 ⁶ Ops.	250	1000	500
Static Contact Resistance (max. init.)	50mV, 10mA	Ω	0.150	0.120	0.125
Dynamic Contact Resistance (max. init.)	0.5V, 50mA at 100 Hz, 1.5 msec	Ω	0.200	0.200	0.15
RELAY SPECIFICATIONS					
Insulation Resistance (minimum)	Between all Isolated Pins at 100V, 25°C, 40% RH	Ω	10 ¹²	10 ¹²	10 ¹²
Capacitance - Typical Across Open Contacts		pF	0.7	0.7	0.1
Open Contact to Coil		pF	1.4	1.4	2.0
Dielectric Strength (minimum)	Between Contacts Contacts to Coil	VDC/peak AC VDC/peak AC	200 500	300 500	200 1500
Operate Time - including bounce - Typical	At Nominal Coil Voltage, 30 Hz Square Wave	msec.	0.35	0.35	0.5
Release Time - Typical	Zener-Diode Suppression ³	msec.	0.1	0.1	0.30

Top View:
Grid = .1"x.1" (2.54mm x 2.54mm)

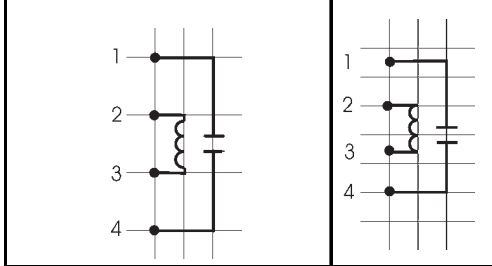

Notes:

¹Consult factory for life expectancy at other switching loads. Resistance >0.5Ω defines end of life or failure to open.

²Optional diode is connected to pin #2 (+) and pin #3(-). Correct coil polarity must be observed.

³Consists of 20V Zener-diode and 1N1002 diode in series, connected in parallel with coil.

⁴9011 external mag shield. 9012 & 9091 internal mag shield.

Environmental Ratings:

Storage Temp: 35°C to +100°C; Operating Temp: 20°C to +85°C
Solder Temp: 270°C max; 10 sec. max

The operate and release voltage and the coil resistance are specified at 25°C. These values vary by approximately 0.4%/°C as the ambient temperature varies.

Vibration: 20 G's to 2000 Hz; Shock: 50 G's