

Description

The μ PD8085A-2, μ PD8085AH, and μ PD8085AH-2 8-bit, single-chip microprocessors are 100 percent software compatible with the industry standard 8080A. They have the ability of increasing system performance of the 8080A by operating at a higher speed. Using the μ PD8085A in conjunction with its family of ICs allows the designer complete flexibility with minimum chip count. The H (HMOS) versions have lower power consumptions than the non-H versions.

Features

- Single power supply, +5 V, $\pm 10\%$
- Internal clock generation and system control
- Internal serial in/out port
- Fully TTL-compatible
- Internal four-level interrupt structure
- Multiplexed address/data bus for increased system performance
- Complete family of components for design flexibility
- Software compatible with industry standard 8080A
- Higher throughput
 - μ PD8085A-2 — 5 MHz
 - μ PD8085AH — 3 MHz
 - μ PD8085AH-2 — 5 MHz

Ordering Information

Part Number	Package Type	Max Frequency of Operation
μ PD8085AC-2	40-pin plastic DIP	5 MHz
μ PD8085AHC	40-pin plastic DIP	3 MHz
μ PD8085AHC-2	40-pin plastic DIP	5 MHz

Pin Configuration

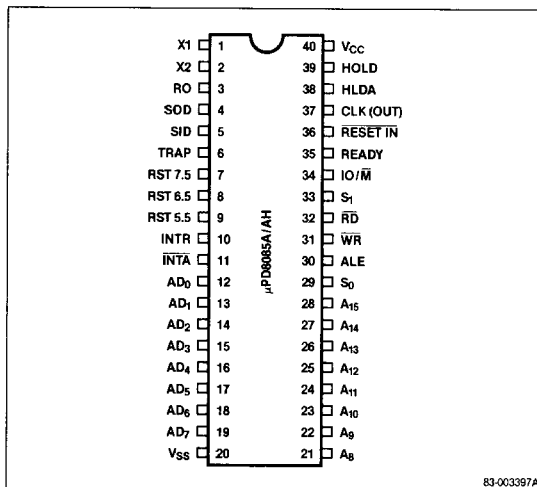

83-00397A

4

Pin Identification

No.	Symbol	Function
1, 2	X1, X2	Crystal in
3	RO	Reset out
4	SOD	Serial out data
5	SID	Serial in data
6	TRAP	Trap interrupt input
7	RST 7.5	Restart interrupts
8	RST 6.5	Restart interrupts
9	RST 5.5	Restart interrupts
10	INTR	Interrupt request in
11	INTA	Interrupt acknowledge
12-19	AD ₀ -AD ₇	Low address / data bus
20	V _{SS}	Ground
21-28	A ₈ -A ₁₅	High address bus
29, 33	S ₀ , S ₁	Status outputs
30	ALE	Address latch enable out
31, 32	WR, RD	Write / read strobes out
34	IO / M	I / O or memory indicator
35	READY	Ready input
36	RESET IN	Reset input
37	CLK	Clock out
38, 39	HLDA, HOLD	Hold acknowledge out and hold input request
40	V _{CC}	+5 V supply

Pin Functions**Crystal In**

Crystal, RC, or external clock input.

Reset Out

Acknowledges that the processor is being reset to be used as a system reset.

Serial Out Data

1-bit data out by the SIM instruction.

Serial In Data

1-bit data into ACC bit 7 by the RIM instruction.

Trap Interrupt Input

Highest priority nonmaskable restart interrupt.

Restart Interrupts

Priority restart interrupt inputs, of which 7.5 is the highest and 5.5 the lowest priority.

Interrupt Request In

A general interrupt input which stops the PC from incrementing, generates \overline{INTA} , and samples the data bus for a restart or call instruction.

Interrupt Acknowledge

An output which indicates that the processor has responded to INTR.

Low Address/Data Bus

Multiplexed low address and data bus.

Ground

Ground Reference.

High Address Bus

Nonmultiplexed high 8 bits of the address bus.

Status Outputs

Outputs which indicate data bus status: Halt, Write, Read, Fetch.

Address Latch Enable Out

A signal which indicates that the lower 8 bits of address are valid on the AD lines.

Write/Read Strobes Out

Signals out which are used as write and read strobes for memory and I/O devices.

I/O or Memory Indicator

A signal out which indicates whether \overline{RD} or \overline{WR} strobes are for I/O or memory devices.

Ready Input

An input which is used to increase the data and address bus access times (can be used for slow memory).

Reset Input

An input which is used to start the processor activity at address 0, resetting IE and HLDA flip-flops.

Clock Out

System clock output.

Hold Acknowledge Out and Hold Input Request

Used to request and indicate that the processor should relinquish the bus for DMA activity. When hold is acknowledged, \overline{RD} , \overline{WR} , IO/\overline{M} , address and data buses are all three-stated.

+5 V Supply

Power supply input.

Block Diagram

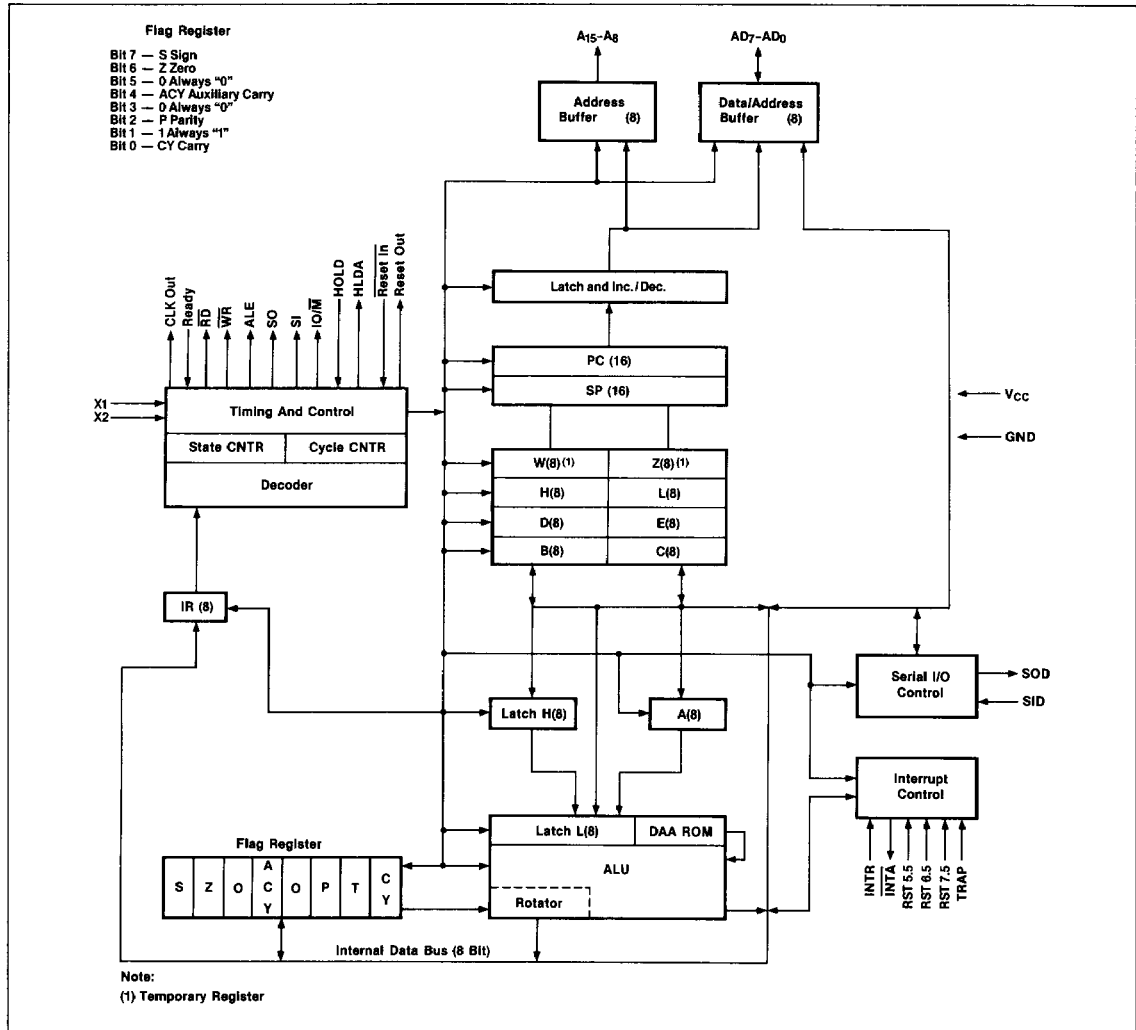

Absolute Maximum Ratings

μPD8085A-2: T_A = 25°C; V_{CC} = +5 V ± 5%

Power supply voltage, V _{DD}	-0.5 V to +7 V
Input voltage, V _I	-0.5 V to +7 V
Output voltage, V _O	-0.5 V to +7 V
Operating temperature, T _{OPR}	0°C to +70°C
Storage temperature, T _{STG}	-65°C to +150°C
Power dissipation, P _D	1.5 W

Comment: Exposing the device to stresses above those listed in Absolute Maximum Ratings could cause permanent damage. The device is not meant to be operated under conditions outside the limits described in the operational sections of this specification. Exposure to absolute maximum rating conditions for extended periods may affect device reliability.

DC Characteristics

μPD8085AH, μPD8085AH-2: T_A = 0°C to +70°C, V_{CC} = +5 V ± 10%, V_{SS} = GND

μPD8085A-2: T_A = 0°C to +70°C, V_{CC} = +5 V ± 5%, V_{SS} = GND

Parameter	Symbol	Limits			Unit	Test Conditions
		Min	Typ	Max		
Input voltage low	V _{IL}	V _{SS} -0.5		V _{SS} +0.8	V	
Input voltage high	V _{IH}	2.0		V _{CC} +0.5	V	
Output voltage low	V _{OL}			+0.45	V	I _{OL} = 2.0 mA, I _{OH} = -400 μA, (Notes 1 & 2)
Output voltage high	V _{OH}	2.4			V	I _{OH} = -400 μA, I _{OL} = 2 mA, (Notes 1 & 2)
Input leakage current	i _{LI}			± 10(1)	μA	0 V ≤ V _{IN} ≤ V _{CC}
Output leakage current	i _{LO}			± 10(1)	μA	0.45 V ≤ V _{OUT} ≤ V _{CC}
Input level low, reset	V _{ILR}	-0.5		+0.8	V	
Input level high, reset	V _{IHR}	2.4		V _{CC} +0.5	V	
Hysteresis, reset	V _{HY}	0.25			V	
X1, X2 input voltage high	V _{IHX}	4.0		V _{CC} +0.5	V	
Power supply current (V _{CC}) μPD8085A-2	I _{CC(AV)}			170	mA	t _{CY} min
μPD8085AH, μPD8085AH-2				135	mA	t _{CY} min, (Note 3)

Note:

- (1) Minus (-) designates current flow out of the device.
- (2) On all outputs.
- (3) Maximum unit test.

AC Characteristics

μPD8085A-2: T_A = 0°C to +70°C, V_{CC} = 5 V ± 5%

μPD8085AH, μPD8085AH-2: T_A = 0°C to +70°C, V_{CC} = 5 V ± 10%

Parameter	Symbol	Limits				Unit	Test Conditions
		μPD8085AH		μPD8085AH-2, μPD8085A-2			
		Min	Max	Min	Max		
CLK cycle period	t _{CYC}	320	2000	200	2000	ns	
CLK low time	t ₁	80		40		ns	
CLK high time	t ₂	120		70		ns	
CLK rise time	t _r		30		30	ns	
CLK fall time	t _f		30		30	ns	
X1 rising to CLK rising	t _{XKR}	30	120	30	100	ns	
X1 rising to CLK falling	t _{XKF}	30	150	30	110	ns	
A ₈ -A ₁₅ valid to leading edge of CONTROL	t _{AC}	270		115		ns	(Note 1)
A ₀ -A ₇ valid to leading edge of CONTROL	t _{ACL}	240		115		ns	
A ₀ -A ₁₅ valid to data input	t _{AD}		575		350	ns	
Address float after leading edge of RD (INTA)	t _{AFR}		0		0	ns	
A ₈ -A ₁₅ valid before trailing edge of ALE	t _{AL}	115		50		ns	(Note 1)
A ₀ -A ₇ valid before trailing edge of ALE	t _{ALL}	90		50		ns	
READY valid from address valid	t _{ARY}		220		100	ns	
A ₈ -A ₁₅ valid after CONTROL	t _{CA}	120		60		ns	
Width of control low (RD, WR, INTA)	t _{CC}	400		230		ns	
Trailing edge of CONTROL to leading edge of ALE	t _{CL}	50		25		ns	
Data valid to trailing edge of WR	t _{DW}	420		230		ns	
HLDA to bus enable	t _{HABE}		210		150	ns	
Bus float after HLDA	t _{HABF}		210		150	ns	
HLDA valid to trailing edge of CLK	t _{HACK}	110		40		ns	
HOLD hold time	t _{HDH}	0		0		ns	
HOLD setup time to trailing edge of CLK	t _{HDS}	170		120		ns	
INTR hold time	t _{INH}	0		0		ns	
INTR, RST, TRAP setup time to trailing edge of CLK	t _{INS}	160		150		ns	
Address hold time after ALE	t _{LA}	100		50		ns	
Trailing edge of ALE to leading edge of CONTROL	t _{LC}	130		60		ns	
ALE low time during CLK high	t _{LCK}	100		50		ns	
ALE to valid data input during read	t _{LDR}		460		270	ns	
ALE to valid data during write	t _{LDW}		200		120	ns	
ALE pulse width	t _{LL}	140		80		ns	
ALE to READY stable	t _{LRY}		110		30	ns	

AC Characteristics (cont)

μPD8085A-2: T_A = 0°C to +70°C, V_{CC} = 5 V ± 5%

μPD8085AH, μPD8085AH-2: T_A = 0°C to +70°C, V_{CC} = 5 V ± 10%

Parameter	Symbol	Limits				Unit	Test Conditions
		μPD8085AH		μPD8085AH-2, μPD8085A-2			
		Min	Max	Min	Max		
Trailing edge of RD to re-enabling of address	t _{RAE}	150		90		ns	
RD (or INTA) to valid data	t _{RD}		300		150	ns	
Trailing edge of CONTROL to leading edge of next CONTROL	t _{RV}	400		220		ns	
Data hold time after RD (INTA)	t _{RDH}	0		0		ns	(Note 7)
READY hold time	t _{RYH}	0		0		ns	
READY setup time to leading edge of CLK	t _{RYS}	110		100		ns	
Leading edge data valid after trailing edge of WR	t _{WD}	100		60		ns	
Leading edge of WR to data valid	t _{WDL}		40		20	ns	

Note:

- A₈-A₁₅ address specs apply to IO/M. S₀ and S₁ except A₈-A₁₅ are undefined during T₄-T₆ of OF cycle whereas IO/M, S₀ and S₁ are stable.
- Test conditions: t_{CYC} = 320 ns (8085AH)/200 ns (8085A-2) C_L = 150 pF
- For all output timing except where C_L = 150 pF use the following correction factors:
 25 pF, C_L = 150 pF: - 0.10 ns/pF
 150 pF, C_L = 300 pF: +0.3 ns/pF
- Output timings are measured with purely capacitive load.
- All timings are measured as the following:
 Output voltage: V_L = 0.8 V, V_H = 2.0 V
 Input voltage: 1.5 V; t_r = 20 ns
- To calculate timing specifications at other values of t_{CYC} use Bus Timing Specifications.
- Data hold time is guaranteed under all loading conditions.

Bus Timing Specifications

t_{CYC} as a Dependent

Symbol	Timing Formula		
	μPD8085AH	μPD8085A-2, μPD8085AH-2	Min/Max
t _{AL}	(1/2) t _{CY} - 45	(1/2) t _{CY} - 50	Min
t _{LA}	(1/2) t _{CY} - 60	(1/2) t _{CY} - 50	Min
t _{LL}	(1/2) t _{CY} - 20	(1/2) t _{CY} - 20	Min
t _{LCK}	(1/2) t _{CY} - 60	(1/2) t _{CY} - 50	Min
t _{LC}	(1/2) t _{CY} - 30	(1/2) t _{CY} - 40	Min
t _{AD}	(5/2 + N) t _{CY} - 225	(5/2 + N) t _{CY} - 150	Max
t _{RD}	(3/2 + N) t _{CY} - 180	(3/2 + N) t _{CY} - 150	Max
t _{RAE}	(1/2) t _{CY} - 10	(1/2) t _{CY} - 10	Min
t _{CA}	(1/2) t _{CY} - 40	(1/2) t _{CY} - 40	Min
t _{DW}	(3/2 + N) t _{CY} - 60	(3/2 + N) t _{CY} - 70	Min
t _{WD}	(1/2) t _{CY} - 60	(1/2) t _{CY} - 40	Min

Symbol	Timing Formula		
	μPD8085AH	μPD8085A-2, μPD8085AH-2	Min/Max
t _{CC}	(3/2 + N) t _{CY} - 80	(3/2 + N) t _{CY} - 70	Min
t _{CL}	(1/2) t _{CY} - 110	(1/2) t _{CY} - 75	Min
t _{ARY}	(3/2) t _{CY} - 260	(3/2) t _{CY} - 200	Max
t _{HACK}	(1/2) t _{CY} - 50	(1/2) t _{CY} - 60	Min
t _{HABF}	(1/2) t _{CY} + 50	(1/2) t _{CY} - 50	Max
t _{HABE}	(1/2) t _{CY} + 50	(1/2) t _{CY} - 50	Max
t _{AC}	(2/2) t _{CY} - 50	(2/2) t _{CY} - 85	Min
t ₁	(1/2) t _{CY} - 80	(1/2) t _{CY} - 60	Min
t ₂	(1/2) t _{CY} - 40	(1/2) t _{CY} - 30	Min
t _{RV}	(3/2) t _{CY} - 80	(3/2) t _{CY} - 80	Min
t _{LDR}	(4/2 + N) t _{CY} - 180	(4/2 + N) t _{CY} - 130	Max

Note:

- N = Number of WAIT state.

Timing Waveforms

Clock Timing Waveform

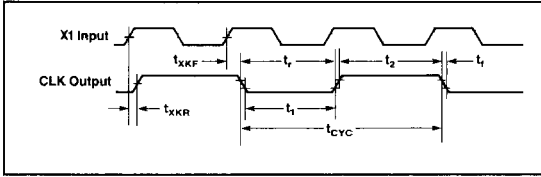

Hold Timing

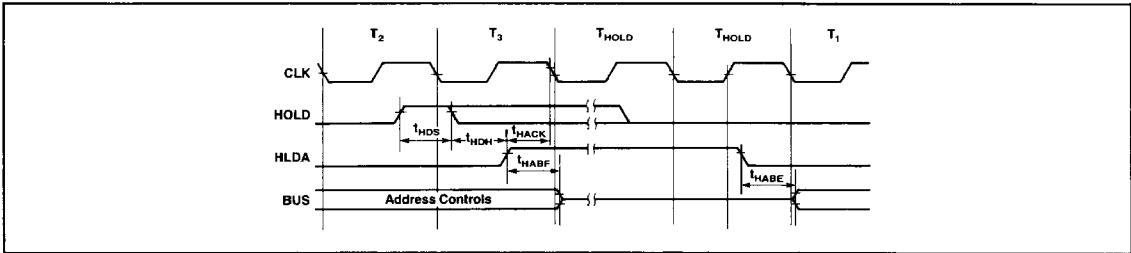

4

8085AH Bus Timing Read Operation

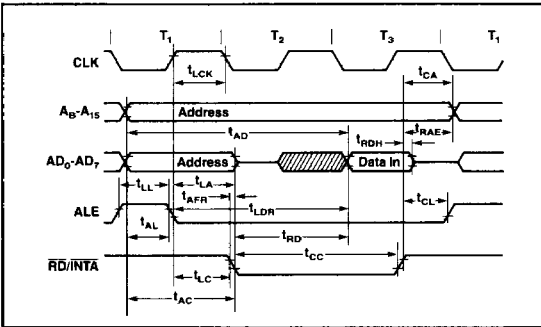

Write Operation

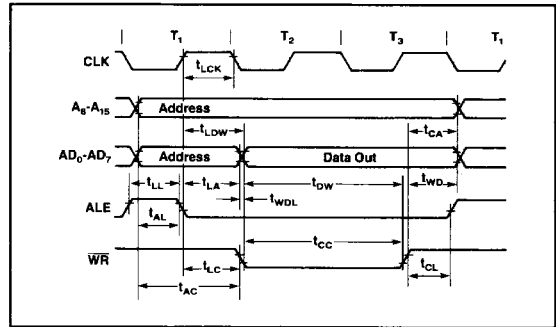

Read Operation with Wait Cycle (same Ready Timing Applies to Write Operation)

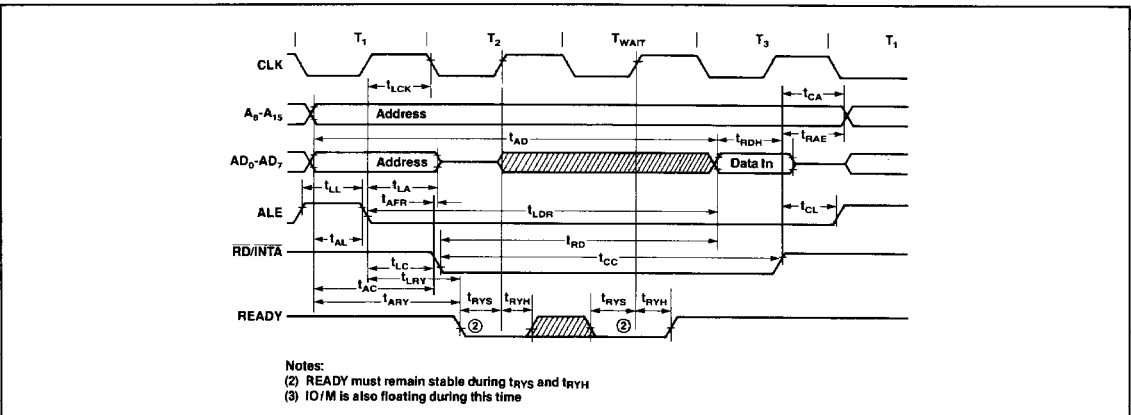

Timing Waveforms (cont)

Interrupt and Hold Timing

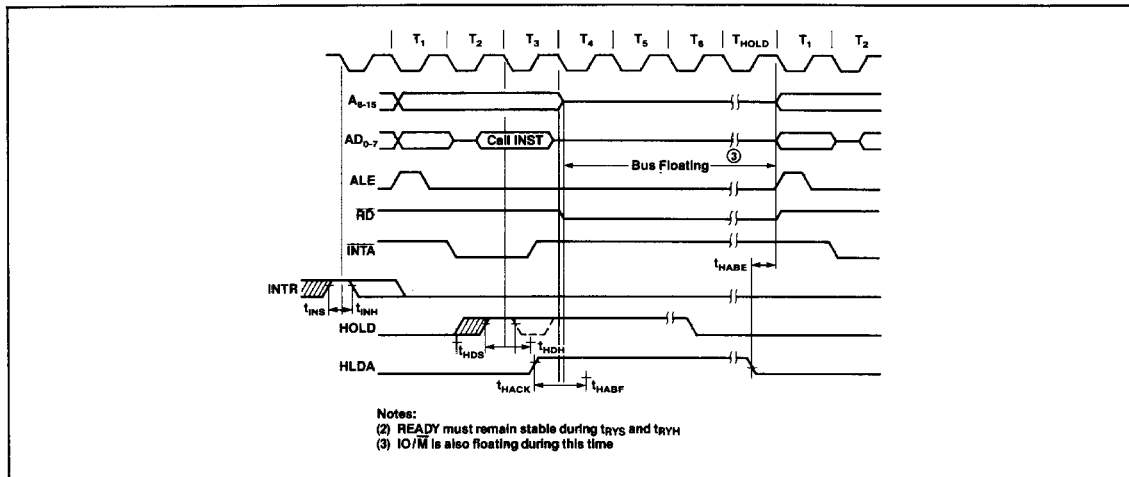

Functional Description

The μPD8085A contains six 8-bit data registers, an 8-bit accumulator, four testable flag bits, and an 8-bit parallel binary arithmetic unit. The μPD8085A also provides decimal arithmetic capability and it includes 16-bit arithmetic and immediate operators which greatly simplify memory address calculations, and high speed arithmetic operations.

The μPD8085A has a stack architecture wherein any portion of the external memory can be used as a last in/first out (LIFO) stack to store/retrieve the contents of the accumulator, the flags, or any of the data registers.

The μPD8085A also contains a 16-bit stack pointer to control the addressing of this external stack. One of the major advantages of the stack is that multiple level interrupts can easily be handled since complete system status can be saved when an interrupt occurs and then restored after the interrupt is complete. Another major advantage is that almost unlimited subroutine nesting is possible.

The μPD8085A was designed with speed and simplicity of the overall system in mind. The multiplexed address/data bus increases available pins for advanced functions in the processor and peripheral

chips while providing increased system speed and less critical timing functions. All signals to and from the μPD8085A are fully TTL-compatible.

The internal interrupt structure of the μPD8085A features 4 levels of prioritized interrupt with three levels internally maskable.

Communication on both the address lines and the data lines can be interlocked by using the HOLD input. When the hold acknowledge (HLDA) signal is issued by the processor, its operation is suspended and the address, data and control lines are forced to be in the FLOATING state. This permits other devices, such as direct memory access channels (DMA), to be connected to the address and data buses.

The μPD8085A features internal clock generation with status outputs available for advanced read/write timing and memory/IO instruction indications. The clock may be crystal controlled, RC controlled, or driven by an external signal.

On-chip serial in/out port is available and controlled by the newly added RIM and SIM instructions.

Processor State Transition Diagram

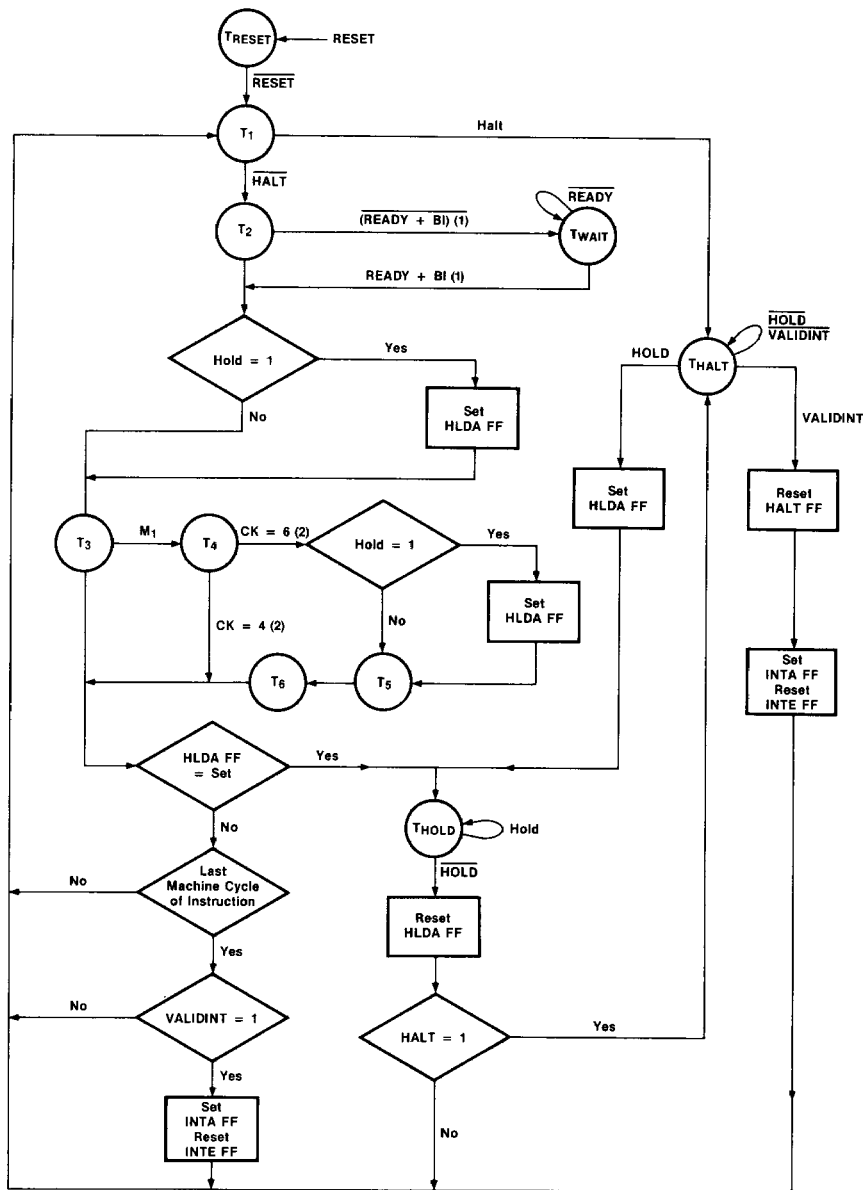

Notes:
 1. BI indicates that the bus is idle during this machine cycle.
 2. CK indicates the number of clock cycles in this machine cycle.

Clock Inputs

As stated, the timing for the μPD8085A may be generated in one of two ways: crystal, or external clock. Recommendations for these methods are shown below. Note the input frequency must be twice the internal operating frequency.

Status Outputs

The status outputs are valid during ALE time and have the following meaning:

	S ₁	S ₀
Halt	0	0
Write	0	1
Read	1	0
Fetch	1	1

These pins may be decoded to portray the processor's data bus status.

Interrupts

The μPD8085A has five interrupt pins available to the user. INTR is operationally the same as the 8080 interrupt request, three (3) internally maskable restart interrupts: RESTART 5.5, 6.5, and 7.5, and TRAP, a non-maskable restart.

Priority	Interrupt	Restart Address
Highest	TRAP	24 ₁₆
	RST 7.5	3C ₁₆
	RST 6.5	34 ₁₆
	RST 5.5	2C ₁₆
Lowest	INTR	

INTR, RST 5.5 and RST 6.5 are all level sensing inputs while RST 7.5 is set on a rising-edge. TRAP, the highest priority interrupt, is non-maskable and is set on the rising-edge or positive level. It must make a low-to-high transition and remain high to be seen, but it will not be generated again until it makes another low-to-high transition.

RC

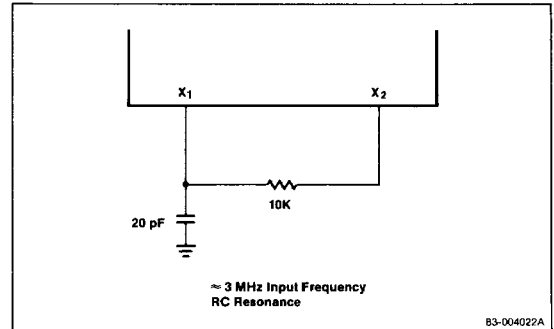

Crystal

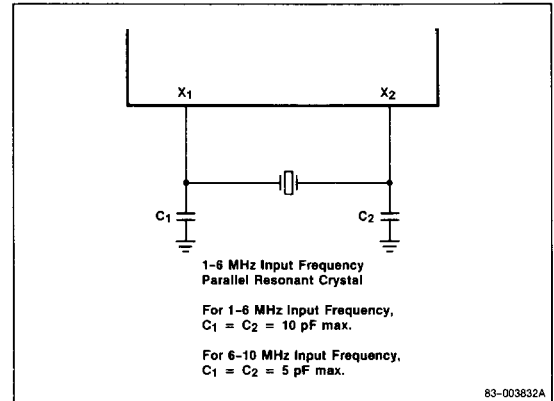

External

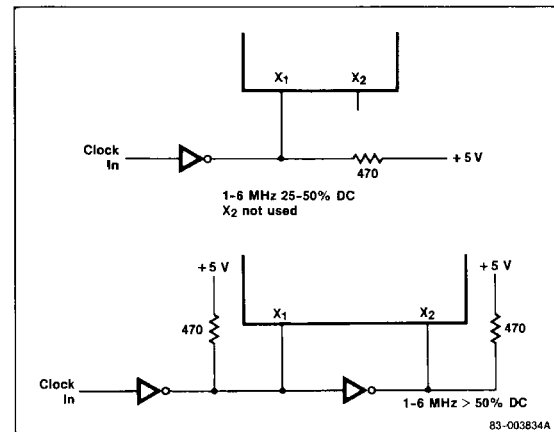

Serial I/O

Serial input and output is accomplished with two new instructions not included in the 8080: RIM and SIM. These instructions serve several purposes: serial I/O, and reading or setting the interrupt mask.

The RIM (Read Interrupt Mask) instruction is used for reading the interrupt mask and for reading serial data. After execution of the RIM instruction the ACC content is as follows:

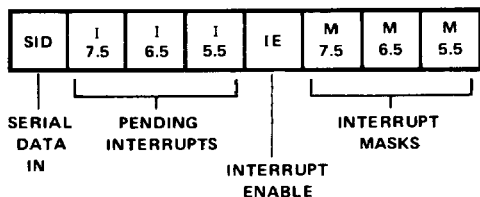

Note:

(1) After the TRAP interrupt, the RIM instruction must be executed to preserve the status of IE.

The SIM (Set Interrupt Mask) instruction is used to program the interrupt mask and to output serial data. Presetting the ACC for the SIM instruction has the following meaning:

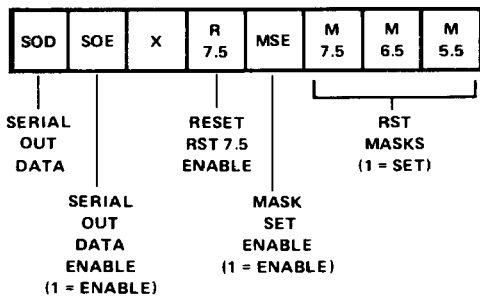

Instruction Set

The instruction set includes arithmetic and logical operators with direct, register, indirect, and immediate addressing modes.

Move, load, and store instruction groups provide the ability to move either 8 or 16 bits of data between memory, the six working registers and the accumulator using direct, register, indirect, and immediate addressing modes.

The ability to branch to different portions of the program is provided with direct, conditional, or computed jumps. Also, the ability to call and return from subroutines is provided both conditionally and unconditionally. The RESTART (or single byte call instruction) is useful for interrupt vector operation.

Conditional jumps, calls and returns execute based on the state of the four testable flags (sign, zero, parity and carry). The state of each flag is determined by the result of the last instruction executed that affected flags. (See Instruction Set Table)

The sign flag is set (high) if bit 7 of the result is a "1"; otherwise it is reset (low). The zero flag is set if the result is "0"; otherwise it is reset. The parity flag is set if the modulo 2 sum of the bits of the result is "0" (even parity); otherwise (odd parity) it is reset. The carry flag is set if the last instruction resulted in a carry or a borrow out of the most significant bit (bit 7) of the result; otherwise it is reset.

In addition to the four testable flags, the μPD8085A has another flag (ACY) that is not directly testable. It is used for multiple precision arithmetic operations with the DAA instruction. The auxiliary carry flag is set if the last instruction resulted in a carry or a borrow from bit 3 into bit 4; otherwise it is reset.

Double precision operators such as stack manipulation and double add instructions extend both the arithmetic and interrupt handling capability of the μPD8085A. The ability to increment and decrement memory, the six general registers, and the accumulator are provided as well as extended increment and decrement instructions to operate on the register pairs and stack pointer. Further capability is provided by the ability to rotate the accumulator left or right through or around the carry bit.

Input and output may be accomplished using memory addresses as I/O ports or the directly addressed I/O provided for in the μPD8085A instruction set.

Two instructions, RIM and SIM, are used for reading and setting the internal interrupt mask as well as input and output to the serial I/O port.

The special instruction group completes the μPD8085A instruction set: NOP, HALT stop processor execution; DAA provides decimal arithmetic capability; STC sets the carry flag; CMC complements it; CMA complements the contents of the accumulator; and XCHG exchanges the contents of two 16-bit register pairs directly.

Data and Instruction Formats

Data in the μPD8085A is stored as 8-bit binary integers. All data/instruction transfers to the system data bus are in the following format:

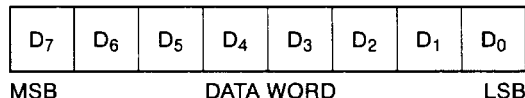

Instructions are one, two, or three bytes long. Multiple byte instructions must be stored in successive locations of program memory. The address of the first byte is used as the address of the instruction.

One Byte Instructions

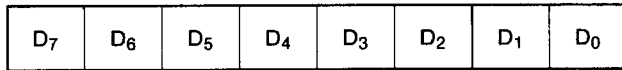

OP CODE

Typical Instructions

Register to register, memory reference, arithmetic or logical, rotate, return, push, pop, enable, or diable interrupt instructions

Two Byte Instructions

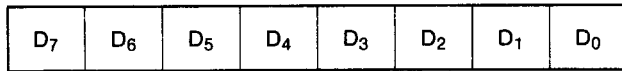

OP CODE

Immediate mode or I/O instructions

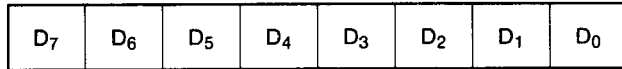

OPERAND

Three Byte Instructions

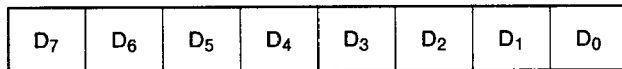

OP CODE

Jump, call or direct load and store instructions

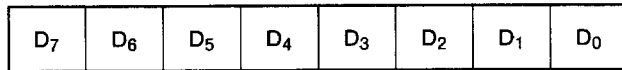

LOW ADDRESS OR OPERAND 1

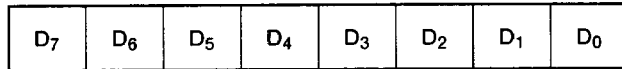

HIGH ADDRESS OR OPERAND 2

Instruction Cycle Times

One to five machine cycles (M₁-M₅) are required to execute an instruction. Each machine cycle involves the transfer of an instruction or data byte into the processor or a transfer of a data byte out of the processor (the sole exception being the double add instruction). The first one, two or three machine cycles obtain the instruction from the memory or an interrupting I/O controller. The remaining cycles are used to execute the instruction. Each machine cycle requires from three to five clock times (T₁-T₅).

Machine cycles and clock states used for each type of instruction are shown below.

Instruction Type	Machine Cycles Executed Min/Max	Clock Status Min/Max
ALU R	1	4
CMC	1	4
CMA	1	4
DAA	1	4
DCR R	1	4
DI	1	4
EI	1	4
INR R	1	4
MOV R, R	1	4
NOP	1	4
ROTATE	1	4
RIM	1	4
SIM	1	4
STC	1	4
XCHG	1	4
HLT	1	5
DCX	1	6
INX	1	6
PCHL	1	6

Instruction Type	Machine Cycles Executed Min/Max	Clock Status Min/Max
RET COND.	1/3	6/12
SPHL	1	6
ALU I	2	7
ALU M	2	7
JNC	2/3	7/10
LDAX	2	7
MVI	2	7
MOV M, R	2	7
MOV R, M	2	7
STAX	2	7
CALL COND.	2/5	9/18
DAD	3	10
DCR M	3	10
IN	3	10
INR M	3	10
JMP	3	10
LOAD PAIR	3	10
MVI M	3	10
OUT	3	10
POP	3	10
RET	3	10
PUSH	3	12
RST	3	12
LDA	4	13
STA	4	13
LHLD	5	16
SHLD	5	16
XTHL	5	16
CALL	5	18

Instruction Set

Mnemonic(s)	Description	Operation Code(2)										Flags(4)			
		D7	D6	D5	D4	D3	D2	D1	D0	Cycles(3)	Sign	Zero	Parity	Carry	
Move															
MOV d, s	Move register to register	0	1	d	d	d	d	s	s	s	4				
MOV M, s	Move register to memory	0	1	1	1	0	s	s	s	7					
MOV d, M	Move memory to register	0	1	d	d	d	1	1	0	7					
MVI d, D8	Move immediate to register	0	0	d	d	d	1	1	0	7					
MVI M, D8	Move immediate to memory	0	0	1	1	0	1	1	0	10					
Increment / Decrement															
INR d	Increment register	0	0	d	d	d	1	0	0	4					
DCR d	Decrement register	0	0	d	d	d	1	0	1	4					
INR M	Increment memory	0	0	1	1	0	1	0	0	10					
DCR M	Decrement memory	0	0	1	1	0	1	0	1	10					
ALU — Register to Accumulator															
ADD s	Add register to A	1	0	0	0	0	s	s	s	4					
ADC s	Add register to A with carry	1	0	0	0	1	s	s	s	4					
SUB s	Subtract register from A	1	0	0	1	0	s	s	s	4					
SUBB s	Subtract register from A with borrow	1	0	0	1	1	s	s	s	4					
ANA s	AND register with A	1	0	1	0	0	s	s	s	4				0	
XRA s	Exclusive OR register with A	1	0	1	0	1	s	s	s	4				0	
ORA s	OR register with A	1	0	1	1	0	s	s	s	4				0	
CMP s	Compare register with A	1	0	1	1	1	s	s	s	4					
ALU — Memory to Accumulator															
ADD M	Add memory to A	1	0	0	0	0	1	1	0	7					
ADC M	Add memory to A with carry	1	0	0	0	1	1	1	0	7					
SUB M	Subtract memory from A	1	0	0	1	0	1	1	0	7					
SBB M	Subtract memory from A with borrow	1	0	0	1	1	1	1	0	7					
ANA M	AND memory with A	1	0	1	0	0	1	1	0	7				0	
XRA M	Exclusive OR memory with A	1	0	1	0	1	1	1	0	7				0	
ORA M	OR memory with A	1	0	1	1	0	1	1	0	7				0	
CMP M	Compare memory with A	1	0	1	1	1	1	1	0	7					
ALU — Immediate to Accumulator															
ADI D8	Add immediate to A	1	1	0	0	0	1	1	0	7					
ACI D8	Add immediate to A with carry	1	1	0	0	1	1	1	0	7					

Instruction Set (cont)

Mnemonic(1)	Description	Operation Code(2)								Flags(4)				
		D7	D6	D5	D4	D3	D2	D1	D0	Cycles(3)	Sign	Zero	Parity	Carry
ALU — Immediate to Accumulator (cont)														
SUI D8	Subtract immediate from A	1	1	0	1	0	1	1	1	0	7	•	•	•
SBI D8	Subtract immediate from A with borrow	1	1	0	1	1	1	1	1	0	7	•	•	•
ANI D8	AND immediate with A	1	1	1	0	0	1	1	0	7	•	•	•	0
XRI D8	Exclusive OR immediate with A	1	1	1	0	1	1	1	1	0	7	•	•	•
ORI D8	OR immediate with A	1	1	1	1	0	1	1	1	0	7	•	•	•
CPI D8	Compare immediate with A	1	1	1	1	1	1	1	0	7	•	•	•	•
ALU — Rotate														
RLC	Rotate A left, MSB to carry (8-bit)	0	0	0	0	0	1	1	1	1	4	•		
RRC	Rotate A right, LSB to carry (8-bit)	0	0	0	0	1	1	1	1	1	4	•		
RAL	Rotate A left through carry (9-bit)	0	0	0	1	0	1	1	1	1	4	•		
RAR	Rotate A right through carry (9-bit)	0	0	0	1	1	1	1	1	1	4	•		
Jump														
JMP ADDR	Jump unconditional	1	1	0	0	0	0	1	1	10				
JNZ ADDR	Jump on not zero	1	1	0	0	0	0	1	0	7/10				
JZ ADDR	Jump on zero	1	1	0	0	1	0	1	0	7/10				
JNC ADDR	Jump on no carry	1	1	0	1	0	0	1	0	7/10				
JC ADDR	Jump on carry	1	1	0	1	1	0	1	0	7/10				
JPO ADDR	Jump on parity odd	1	1	1	0	0	0	1	0	7/10				
JPE ADDR	Jump on parity even	1	1	1	0	1	0	1	0	7/10				
JP ADDR	Jump on positive	1	1	1	1	0	0	1	0	7/10				
JM ADDR	Jump on minus	1	1	1	1	1	0	1	0	7/10				
Call														
CALL ADDR	Call unconditional	1	1	0	0	1	1	0	1	18				
CNZ ADDR	Call on not zero	1	1	0	0	0	1	0	0	9/18				
CZ ADDR	Call on zero	1	1	0	0	1	1	0	0	9/18				
CNC ADDR	Call on no carry	1	1	0	1	0	1	0	0	9/18				
CC ADDR	Call on carry	1	1	0	1	1	1	0	0	9/18				
CPO ADDR	Call on parity odd	1	1	1	0	0	1	0	0	9/18				
CPE ADDR	Call on parity even	1	1	1	0	1	1	0	0	9/18				
CP ADDR	Call on positive	1	1	1	1	0	1	0	0	9/18				
CM ADDR	Call on minus	1	1	1	1	1	1	0	0	9/18				

Instruction Set (cont)

Mnemonic(1)	Description	Operation Code(2)										Flags(4)					
		D7	D6	D5	D4	D3	D2	D1	D0	Cycles(3)	Sign	Zero	Parity	Carry			
Call (cont)																	
Return	Return	1	1	0	0	1	0	0	1	0	0	1	10				
RNZ	Return on not zero	1	1	0	0	0	0	0	0	0	0	0	6/12				
RZ	Return on zero	1	1	0	0	1	0	0	0	0	0	0	6/12				
RNC	Return on no carry	1	1	0	1	0	0	0	0	0	0	0	6/12				
RC	Return on carry	1	1	0	1	1	0	0	0	0	0	0	6/12				
RPO	Return on parity odd	1	1	1	0	0	0	0	0	0	0	0	6/12				
RPE	Return on parity even	1	1	1	0	1	0	0	0	0	0	0	6/12				
RP	Return on positive	1	1	1	1	0	0	0	0	0	0	0	6/12				
RM	Return on minus	1	1	1	1	1	0	0	0	0	0	0	6/12				
Load Register Pair																	
LXI B, D16	Load immediate register pair BC	0	0	0	0	0	0	0	0	1	0	1	10				
LXI D, D16	Load immediate register pair DE	0	0	0	1	0	0	0	0	1	0	1	10				
LXI H, D16	Load immediate register pair HL	0	0	1	0	0	0	0	0	1	0	1	10				
LXI SP, D16	Load immediate stack pointer	0	0	1	1	0	0	0	0	1	0	1	10				
Push																	
PUSH B	Push register pair BC on stack	1	1	0	0	0	1	0	1	0	1	12					
PUSH D	Push register pair DE on stack	1	1	0	1	0	1	0	1	0	1	12					
PUSH H	Push register pair HL on stack	1	1	1	0	0	1	0	1	0	1	12					
PUSH PSW	Push A and flags on stack	1	1	1	1	0	1	0	1	0	1	12					
Pop																	
POP B	Pop register pair BC off stack	1	1	0	0	0	0	0	0	1	0	1	10				
POP D	Pop register pair DE off stack	1	1	0	1	0	0	0	0	1	0	1	10				
POP H	Pop register pair HL off stack	1	1	1	0	0	0	0	0	1	0	1	10				
POP PSW	Pop A and flags off stack	1	1	1	1	0	0	0	0	1	0	1	10	•	•	•	•
Double Add																	
DAD R	Add BC to HL	0	0	0	0	1	0	0	1	0	0	1	10				•
DAD D	Add DE to HL	0	0	0	1	1	0	0	1	0	0	1	10				•
DAD H	Add HL to HL	0	0	1	0	1	0	0	1	0	0	1	10				•
DAD SP	Add stack pointer to HL	0	0	1	1	1	0	0	1	0	0	1	10				•

Instruction Set (cont)

Mnemonic(1)	Description	Operation Code(2)								Flags(4)				
		D7	D6	D5	D4	D3	D2	D1	D0	Cycles(3)	Sign	Zero	Parity	Carry
Increment Register Pair														
INX B	Increment BC	0	0	0	0	0	0	1	1	6				
INX D	Increment DE	0	0	0	1	0	0	1	1	6				
INX H	Increment HL	0	0	1	0	0	0	1	1	6				
INX SP	Increment stack pointer	0	0	1	1	0	0	1	1	6				
Decrement Register Pair														
DCX B	Decrement BC	0	0	0	0	1	0	1	1	6				
DCX D	Decrement DE	0	0	0	1	1	0	1	1	6				
DCX H	Decrement HL	0	0	1	0	1	0	1	1	6				
DCX SP	Decrement stack pointer	0	0	1	1	1	0	1	1	6				
Register Indirect														
STAX B	Store A at ADDR in BC	0	0	0	0	0	0	1	0	7				
STAX D	Store A at ADDR in DE	0	0	0	1	0	0	1	0	7				
LDAX B	Load A at ADDR in BC	0	0	0	0	1	0	1	0	7				
LDAX D	Load A at ADDR in DE	0	0	0	1	1	0	1	0	7				
Direct														
STA ADDR	Store A direct	0	0	1	1	0	0	1	0	13				
LDA ADDR	Load A direct	0	0	1	1	1	0	1	0	13				
SHLD ADDR	Store HL direct	0	0	1	0	0	0	1	0	16				
LHLD ADDR	Load HL direct	0	0	1	0	1	0	1	0	16				
Move Register Pair														
XCHG	Exchange DE and HL register pairs	1	1	1	0	1	0	1	1	4				
XTHL	Exchange top of stack and HL	1	1	1	0	0	0	1	1	16				
SPLH	HL to stack pointer	1	1	1	1	1	0	0	1	6				
PCHL	HL to program counter	1	1	1	0	1	0	0	1	6				
Input / Output														
IN A	Input	1	1	0	1	1	0	1	1	10				
OUT A	Output	1	1	0	1	0	0	1	1	10				
EI	Enable interrupts	1	1	1	1	1	0	1	1	4				
DI	Disable interrupts	1	1	1	1	0	0	1	1	4				
RIM	Read interrupt mask	0	0	1	0	0	0	0	0	4				
SIM	Set interrupt mask	0	0	1	1	0	0	0	0	4				
RST A	Restart	1	1	A	A	A	1	1	1	12				

Instruction Set (cont)

Miscellaneous	Mnemonic(1)	Description	Operation Code(2)										Flags(4)											
			D ₇	D ₆	D ₅	D ₄	D ₃	D ₂	D ₁	D ₀	Cycles(3)	Sign	Zero	Parity	Carry									
	CMA	Complement A	0	0	1	0	1	1	1	1	1	1	1	1	1	1	1	1	1	1	1	1	1	1
	STC	Set carry	0	0	1	1	0	1	1	1	1	1	1	1	1	1	1	1	1	1	1	1	1	1
	CMC	Complement carry	0	0	1	1	1	1	1	1	1	1	1	1	1	1	1	1	1	1	1	1	1	1
	DAA	Decimal adjust A	0	0	1	0	0	1	1	1	1	1	1	1	1	1	1	1	1	1	1	1	1	1
	NOP	No operation	0	0	0	0	0	0	0	0	0	0	0	0	0	0	0	0	0	0	0	0	0	0
	HLT	Halt	0	1	1	1	1	0	1	0	1	1	0	1	0	1	0	1	0	1	0	1	0	1

Note:

- (1) Operand symbols used
 A = 8-bit address or expression
 s = source register
 d = destination register
 PSW = Processor status word
 SP = Stack pointer
 D8 = 8-bit data quantity, expression, or constant, always B₂ of instruction
 D16 = 16-bit data quantity, expression, or constant, always B₃B₂ of instruction
 ADDR = 16-bit memory address expression
- (2) odd or sss = 000-B, 001-C, 010-D, 011-E, 100-H, 101-L, 110-Memory, 111-A
- (3) Two possible cycle times (7/10) indicate instruction cycles dependent on condition flags.
- (4) • = flag affected
 = flag not affected
 0 = flag reset
 1 = flag set

μPD8085A Family Minimum System Configuration

A minimum computer system consisting of a processor, ROM, RAM, and I/O can be built with only 3 40-pin

packs. This system is shown with its address, data, control buses and I/O ports.

Three Pack Computer System

