

CMOS 8-Bit Microcontroller

TMP87PH40AN, TMP87PH40AF, TMP87PM40AN, TMP87PM40AF

The 87PH40A is a One-Time PROM microcontroller with low-power 128 K bits (16 Kbytes) electrically programmable read only memory for the 87C840/CC40/CH40 system evaluation. The 87PM40A is a One-time PROM microcontroller with low-power 256 K bits (32 Kbytes) electrically programmable read only memory for the 87CK40A/M40A system evaluation. The 87PH40A/PM40A are pin compatible with the 87C840/CC40/CH40/CK40A/CM40A. The operations possible with the 87C840/CC40/CH40/CK40A/CM40A can be performed by writing programs to PROM. The 87PH40A/PM40A can write and verify in the same way as the TC57256AD using an adaptor socket BM1136/BM1137 and an EPROM programmer.

Part No	OTP	RAM	Package	Adapter socket
TMP87PH40AN	16 K x 8-bit	512 x 8-bit	P-SDIP64-750-1.78	BM1136
TMP87PH40AF			P-QFP64-1420-1.00A	BM1137
TMP87PM40AN	32 K x 8-bit	1K x 8-bit	P-SDIP64-750-1.78	BM1136
TMP87PM40AF			P-QFP64-1420-1.00A	BM1137

Pin Assignments (Top View) - (1)

P-SDIP64-750-1.78

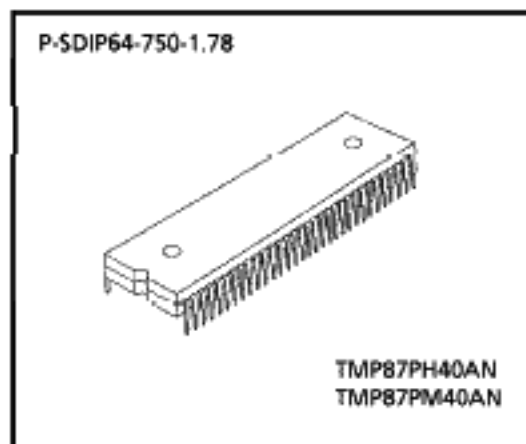
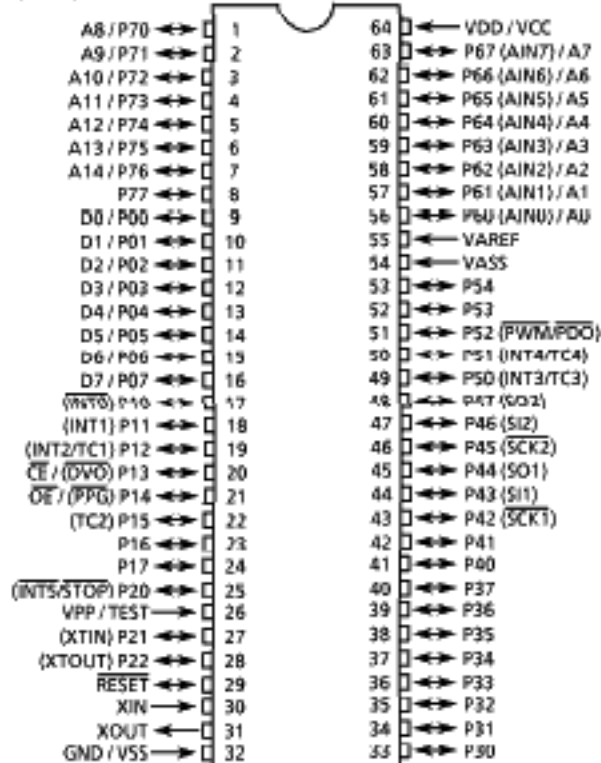

980910EBP1

- For a discussion of how the reliability of microcontrollers can be predicted, please refer to Section 1.3 of the chapter entitled Quality and Reliability Assurance/Handling Precautions.
- TOSHIBA is continually working to improve the quality and the reliability of its products. Nevertheless, semiconductor devices in general can malfunction or fail due to their inherent electrical sensitivity and vulnerability to physical stress. It is the responsibility of the buyer, when utilizing TOSHIBA products, to observe standards of safety, and to avoid situations in which a malfunction or failure of a TOSHIBA product could cause loss of human life, bodily injury or damage to property. In developing your designs, please ensure that TOSHIBA products are used within specified operating ranges as set forth in the most recent products specifications. Also, please keep in mind the precautions and conditions set forth in the TOSHIBA Semiconductor Reliability Handbook.
- The products described in this document are subject to the foreign exchange and foreign trade laws.
- The information contained herein is presented only as a guide for the applications of our products. No responsibility is assumed by TOSHIBA CORPORATION for any infringements of intellectual property or other rights of the third parties which may result from its use. No license is granted by implication or otherwise under any intellectual property or other rights of TOSHIBA CORPORATION or others.
- The information contained herein is subject to change without notice.

Pin Assignments (Top View) - (2)

P-QFP64-1420-1.00A

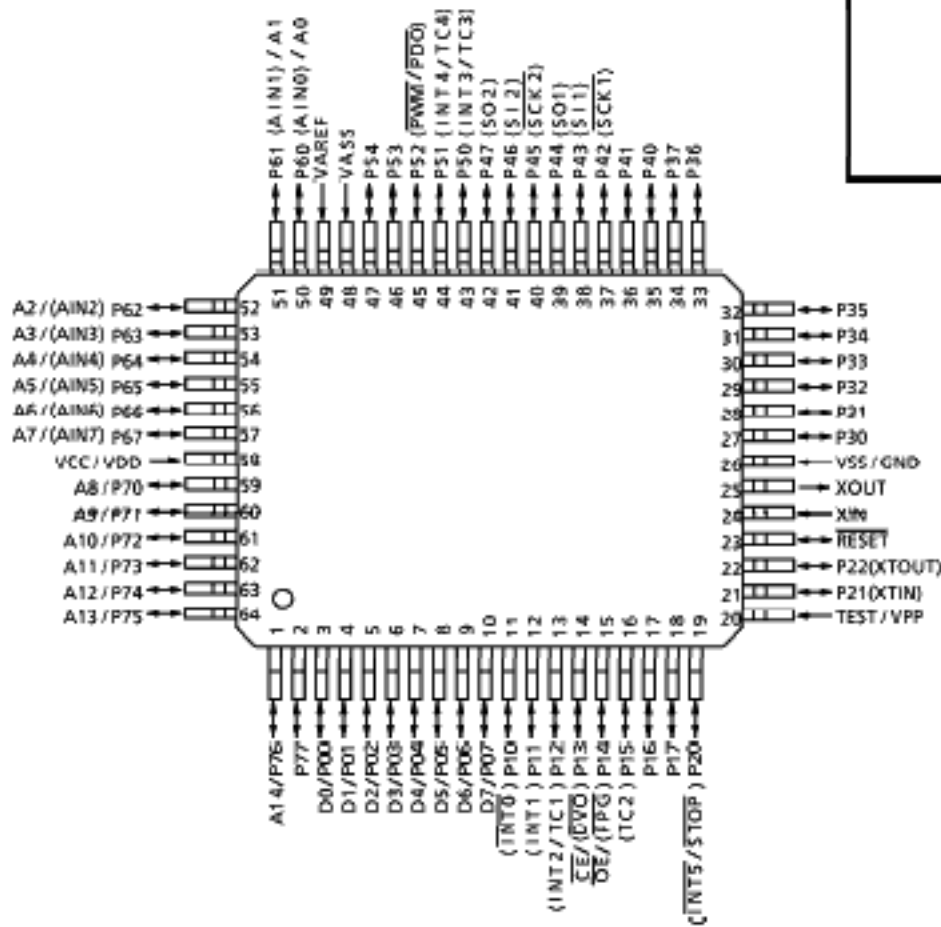
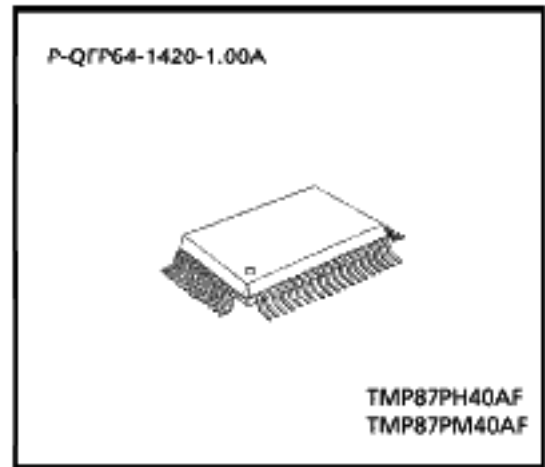

Pin Function

The 87PH40A/PM40A have two modes: MCU and PROM.

(1) MCU mode

In this mode, the 87PH40A/PM40A are pin compatible with the 87C840/CC40/CH40/CK40A/CM40A (fix the TEST pin at low level).

(2) PROM mode

Pin Name (PROM mode)	Input/Output	Functions	Pin Name (MCU mode)
A14 to A8	Input	PROM address inputs	P76 to P70
A7 to A0			P67 to P60
D7 to D0	I/O	PROM data input/outputs	P07 to P00
\overline{CE}	Input	Chip enable signal input (active low)	P13
\overline{OE}		Output enable signal input (active low)	P14
VPP	Power supply	+ 12.5V / 5V (Program supply voltage)	TEST
VCC		+ 5V	VDD
GND		0V	VSS
P37 to P30	I/O	Pull-up with resistance for input processing	PROM mode setting pins. Be fixed at high level.
P47 to P40			
P54 to P50			
P11		PROM mode setting pins. Be fixed at low level.	
P21			
P77			
P17 to P15			
P12, P10			
P22, P20			
RESET			
XIN	Input	Connect an 8MHz oscillator to stabilize the internal state.	
XOUT	Output		
VAREF	Power Supply	0 V (GND)	
VASS			

Operational Description

The following explains the 87PH40A/PM40A hardware configuration and operation. The configuration and functions of the 87PH40A are the same as those of the 87C840/CC40/CH40, 87PM40A are the same as those of the 87CK40A/CM40A, except in that a one-time PROM is used instead of an on-chip mask ROM.

The 87PH40A/PM40A are placed in the single-clock mode during reset. To use the dual-clock mode, the low-frequency oscillator should be turned on by executing [SET (SYSCR2). XTEN] instruction at the beginning of the program.

1. Operating Mode

The 87PH40A/PM40A have two modes: MCU and PROM.

1.1 MCU Mode

The MCU mode is activated by fixing the TEST / VPP pin at low level.

In the MCU mode, operation is the same as with the 87C840/CC40/CH40/CK40A/CM40A (the TEST / VPP pin cannot be used open because it has no built-in pull-down resistance).

1.1.1 Program Memory

The 87PH40A has a 16 K × 8-bit (addresses C000_H to FFFF_H in the MCU mode, addresses 4000_H to 7FFF_H in the PROM mode), the 87PM40A has a 32 K × 8-bit (address 8000_H to FFFF_H in the MCU mode, address 0000_H to 7FFF_H in the PROM mode) of program memory (OTP).

To use the 87PH40A/PM40A as the system evaluation for the 87C840/CC40/CH40/CK40A/CM40A, the program should be written to the program memory area as shown in Figure 1-1.

Electrical Characteristics

Absolute Maximum Ratings

 $(V_{SS} = 0V)$

Parameter	Symbol	Conditions	Ratings	Unit
Supply Voltage	V_{DD}		- 0.3 to 7	V
Program Voltage	V_{PP}	TEST / V_{PP} pin	- 0.3 to 13.0	V
Input Voltage	V_{IN}		- 0.3 to $V_{DD} + 0.3$	V
Output Voltage	V_{OUT1}	Except sink open drain pin, but include P2 and RESET	- 0.3 to $V_{DD} + 0.3$	V
	V_{OUT2}	Sink open drain pin except port P2, RESET	- 0.3 to 10	
Output Current (Per 1 pin)	I_{OUT1}	Ports P0, P1, P2, P4, P5, P6, P7	3.2	mA
	I_{OUT2}	Port P3	30	
Output Current (Total)	ΣI_{OUT1}	Ports P0, P1, P2, P4, P5, P6, P7	120	mA
	ΣI_{OUT2}	Port P3	120	
Power Dissipation [$T_{opr} = 70^{\circ}C$]	PD	TMP87PH40AN/PM40AN	600	mW
		TMP87PH40AF/PM40AF	350	
Soldering Temperature (time)	T_{sld}		260 (10s)	$^{\circ}C$
Storage Temperature	T_{stg}		- 55 to 125	$^{\circ}C$
Operating Temperature	T_{opr}		- 30 to 70	$^{\circ}C$

Note: The absolute maximum ratings are rated values which must not be exceeded during operation, even for an instant. Any one of the ratings must not be exceeded. If any absolute maximum rating is exceeded, a device may break down or its performance may be degraded, causing it to catch fire or explode resulting in injury to the user. Thus, when designing products which include this device, ensure that no absolute maximum rating value will ever be exceeded.

Recommended Operating Conditions

 $(V_{SS} = 0V, T_{opr} = -30 \text{ to } 70^{\circ}C)$

Parameter	Symbol	Pins	Conditions	Min	Max	Unit	
Supply Voltage	V_{DD}		$f_c = 8 \text{ MHz}$	NORMAL1, 2 mode	4.5	6.0	V
				IDLE1, 2 mode			
			$f_c = 4.2 \text{ MHz}$	NORMAL1, 2 mode	2.7		
				IDLE1, 2 mode			
			$f_s = 32.768 \text{ kHz}$	SLOW mode	2.0		
SLEEP mode							
Input High Voltage	V_{IH1}	Except hysteresis input	$V_{DD} \geq 4.5 \text{ V}$	$V_{DD} \times 0.70$	V_{DD}	V	
	V_{IH2}	Hysteresis input		$V_{DD} \times 0.75$			
	V_{IH3}			$V_{DD} < 4.5 \text{ V}$			$V_{DD} \times 0.90$
Input Low Voltage	V_{IL1}	Except hysteresis input	$V_{DD} \geq 4.5 \text{ V}$	0	$V_{DD} \times 0.30$	V	
	V_{IL2}	Hysteresis input			$V_{DD} \times 0.25$		
	V_{IL3}				$V_{DD} < 4.5 \text{ V}$		$V_{DD} \times 0.10$
Clock Frequency	f_c	XIN, XOUT	$V_{DD} = 4.5 \text{ to } 6 \text{ V}$	0.4	8.0	MHz	
			$V_{DD} = 2.7 \text{ to } 6 \text{ V}$		4.2		
	f_s	XTIN, XTOUT		30.0	34.0	kHz	

Note 1: The recommended operating conditions for a device are operating conditions under which it can be guaranteed that the device will operate as specified. If the device is used under operating conditions other than the recommended operating conditions (supply voltage, operating temperature range, specified AC/DC values etc.), malfunction may occur. Thus, when designing products which include this device, ensure that the recommended operating conditions for the device are always adhered to.

Note 2: Clock frequency f_c ; Supply voltage range is specified in NORMAL mode and IDLE mode.

D.C. Characteristics

 $(V_{SS} = 0\text{ V}, T_{opr} = -30\text{ to }70^{\circ}\text{C})$

Parameter	Symbol	Pins	Conditions	Min	Typ.	Max	Unit	
Hysteresis Voltage	V_{HS}	Hysteresis inputs	$V_{DD} = 5.0\text{ V}$	-	0.9	-	V	
Input Current	I_{IN1}	TEST	$V_{DD} = 5.5\text{ V}$ $V_{IN} = 5.5\text{ V}/0\text{ V}$	-	-	± 2	μA	
	I_{IN2}	Open drain ports and tri-state ports						
	I_{IN3}	RESET, STOP						
Input Resistance	R_{IN2}	RESET		100	220	450	k Ω	
Output Leakage Current	I_{LO1}	Open drain ports	$V_{DD} = 5.5\text{ V}, V_{OUT} = 5.5\text{ V}$	-	-	2	μA	
	I_{LO2}	Tri-state ports	$V_{DD} = 5.5\text{ V}, V_{OUT} = 5.5\text{ V}/0\text{ V}$	-	-	± 2		
Output High Voltage	V_{OH2}	Tri-state ports	$V_{DD} = 4.5\text{ V}, I_{OH} = -0.7\text{ mA}$	4.1	-	-	V	
Output Low Voltage	V_{OL}	Except XOUT and port P3	$V_{DD} = 4.5\text{ V}, I_{OL} = 1.6\text{ mA}$	-	-	0.4	V	
Output Low Current	I_{OL3}	Port P3	$V_{DD} = 4.5\text{ V}, V_{OL} = 1.0\text{ V}$	-	20	-	mA	
Supply Current in NORMAL 1, 2 mode	I_{DD}		$V_{DD} = 5.5\text{ V}$ $f_c = 8\text{ MHz}$	87PH40A	-	9	14	mA
Supply Current in IDLE 1, 2 mode				87PM40A	-	12	18	
Supply Current in SLOW mode			$V_{DD} = 3.0\text{ V}$ $f_s = 32.768\text{ kHz}$	87PH40A	-	4	6	μA
Supply Current in SLEEP mode				87PM40A	-	4.5	6	
Supply Current in STOP mode			$V_{DD} = 5.5\text{ V}$ $V_{IN} = 5.3\text{ V}/0.2\text{ V}$	-	-	15	30	μA
Supply Current in STOP mode				-	-	0.5	10	

Note 1: Typical values show those at $T_{opr} = 25^{\circ}\text{C}$.

Note 2: Input Current I_{IN1}, I_{IN3} ; The current through pull-up or pull-down resistor is not included.

Note 3: I_{DD} ; Except for I_{REF}

A / D Conversion Characteristics

 $(V_{SS} = 0\text{ V}, V_{DD} = 2.7\text{ to }5.5\text{ V}, T_{opr} = -30\text{ to }70^{\circ}\text{C})$

Parameter	Symbol	Conditions	Min	Typ.	Max	Unit
Analog Reference Voltage	V_{AREF}	$V_{AREF} - V_{ASS} \geq 2.5\text{ V}$	2.7	-	V_{DD}	V
	V_{ASS}		V_{SS}	-	1.5	
Analog Input Voltage	V_{AIN}		V_{ASS}	-	V_{AREF}	V
Analog Supply Current	I_{REF}	$V_{AREF} = 5.5\text{ V}, V_{ASS} = 0.0\text{ V}$	-	0.5	1.0	mA
Nonlinearity Error		$V_{DD} = 5.0\text{ V}, V_{SS} = 0.0\text{ V}$ $V_{AREF} = 5.000\text{ V}$ $V_{ASS} = 0.000\text{ V}$	-	-	± 1	LSB
Zero Point Error		or $V_{DD} = 2.7\text{ V}, V_{SS} = 0.0\text{ V}$ $V_{AREF} = 2.700\text{ V}$ $V_{ASS} = 0.000\text{ V}$	-	-	± 1	
Full Scale Error			-	-	± 1	
Total Error			-	-	± 2	

Note: The above errors has no quantizing error.

A.C. Characteristics		$(V_{SS} = 0\text{ V}, V_{DD} = 4.5\text{ to }6.0\text{ V}, T_{opr} = -30\text{ to }70^{\circ}\text{C})$				
Parameter	Symbol	Conditions	Min	Typ.	Max	Unit
Machine Cycle Time	t_{cy}	In NORMAL1, 2 modes	0.5	-	10	μs
		In IDLE1, 2 modes				
		In SLOW mode	117.6	-	133.3	
		In SLEEP mode				
High Level Clock Pulse Width	t_{WCH}	For external clock operation (XIN input), $f_c = 8\text{ MHz}$	50	-	-	ns
Low Level Clock Pulse Width	t_{WCL}					
High Level Clock Pulse Width	t_{WSH}	For external clock operation (XTIN input), $f_s = 32.768\text{ kHz}$	14.7	-	-	μs
Low Level Clock Pulse Width	t_{WSL}					

Recommended Oscillating Conditions		$(V_{SS} = 0\text{ V}, V_{DD} = 4.5\text{ to }6.0\text{ V}, T_{opr} = -30\text{ to }70^{\circ}\text{C})$				
Parameter	Oscillator	Oscillation Frequency	Recommended Oscillator		Recommended Constant	
					C_1	C_2
High-frequency Oscillation	Ceramic Resonator	8 MHz	KYOCERA	KBR8.0M	30pF	30pF
		4 MHz	KYOCERA	KBR4.0M5		
	Crystal Oscillator	8 MHz	TOYOCOM	210B 8.0000	20pF	20pF
		4 MHz	TOYOCOM	204B 4.0000		
Low-frequency Oscillation	Crystal Oscillator	32.768 kHz	NDK	MX-38T	15pF	15pF

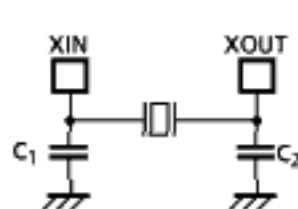

(1) High-frequency Oscillation

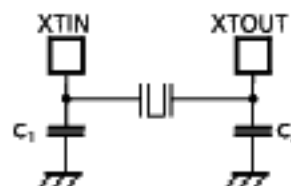

(2) Low-frequency Oscillation

Note: When used in high electric field such as a picture tube, the package is recommended to be electrically shielded to maintain a regular operation.

D.C./A.C. Characteristics (PROM mode) ($V_{SS} = 0V$)(1) Read Operation ($T_{opr} = -30$ to $70^{\circ}C$)

Parameter	Symbol	Conditions	Min	Typ.	Max	Unit
Input High Voltage	V_{IH4}		$V_{CC} \times 0.7$	–	V_{CC}	V
Input Low Voltage	V_{IL4}		0	–	$V_{CC} \times 0.12$	V
Power Supply Voltage	V_{CC}		4.75	5.00	5.25	V
Program Power Supply Voltage	V_{PP}		$V_{CC} - 0.6$	V_{CC}	$V_{CC} + 0.6$	
Address Access Time	t_{ACC}	$V_{CC} = 5.0 \pm 0.25V$	–	$1.5t_{cyc} + 300$	–	ns

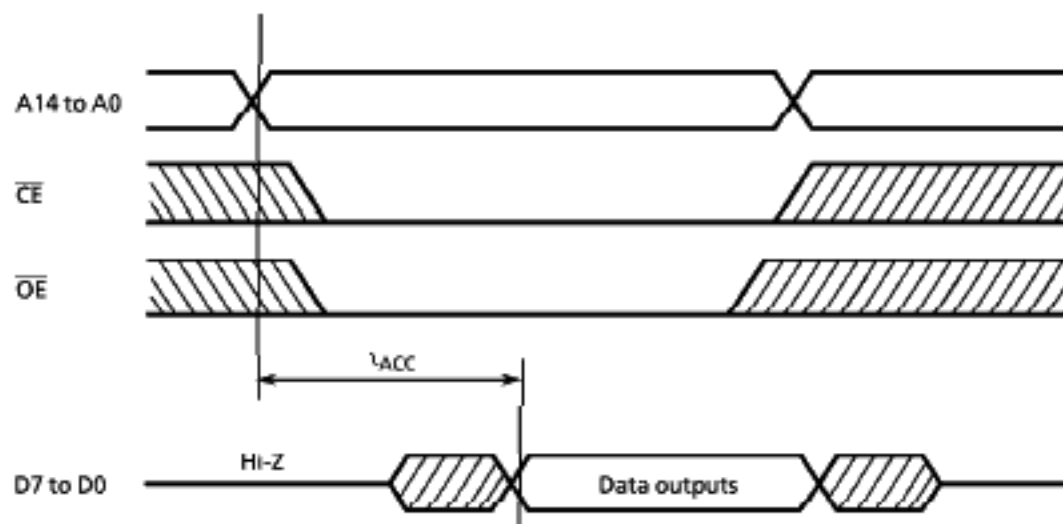
Note: $t_{cyc} = 500$ ns at 8 MHz

Timing Waveforms of Read Operation

(2) Program Operation (High-Speed Write Mode - I) ($T_{opr} = 25 \pm 5^{\circ}C$)

Parameter	Symbol	Conditions	Min	Typ.	Max	Unit
Input High Voltage	V_{IH4}		$V_{CC} \times 0.7$	–	V_{CC}	V
Input Low Voltage	V_{IL4}		0	–	$V_{CC} \times 0.12$	V
Power Supply Voltage	V_{CC}		5.75	6.0	6.25	V
Program Power Supply Voltage	V_{PP}		12.0	12.5	13.0	V
Initial Program Pulse Width	t_{PW}	$V_{CC} = 6.0 V \pm 0.25 V$, $V_{PP} = 12.5 \pm 0.25 V$	0.95	1.0	1.05	ms

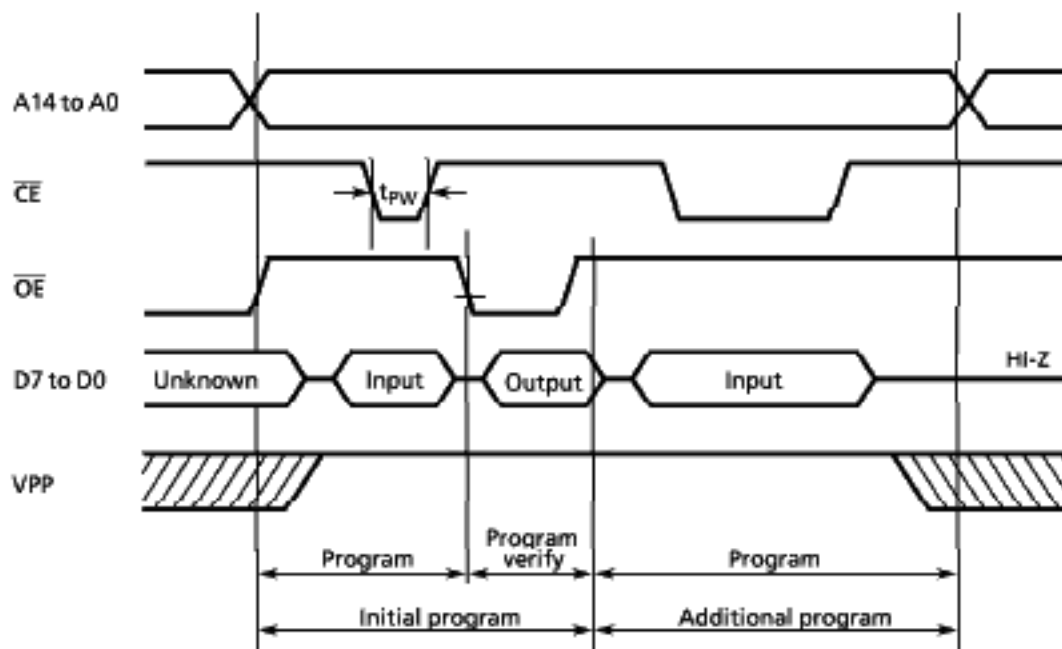

Timing Waveforms of Programming Operation

Note 1: When V_{CC} power supply is turned on or after, V_{PP} must be increased.

When V_{CC} power supply is turned off or before, V_{PP} must be decreased.

Note 2: The device must not be set to the EPROM programmer or picked up from it under applying the program voltage ($12.5\text{ V} \pm 0.5\text{ V}$) to the V_{PP} pin as the device is damaged.

Note 3: Be sure to execute the recommended programming mode with the recommended programming adaptor. If a mode or an adaptor except the above, the misoperation sometimes occurs.

(3) Program Operation (High speed write mode - II) ($T_{op} = 25 \pm 5^{\circ}\text{C}$)

Parameter	Symbol	Conditions	Min	Typ.	Max	Unit
Input High Voltage	V_{IH4}		$V_{CC} \times 0.7$	-	V_{CC}	V
Input Low Voltage	V_{IL4}		0	-	$V_{CC} \times 0.12$	V
Supply Voltage	V_{CC}		6.00	6.25	6.50	V
Program Supply Voltage	V_{PP}		12.50	12.75	13.0	V
Initial Program Pulse Width	t_{PW}	$V_{CC} = 6.25 \text{ V} \pm 0.25 \text{ V}$, $V_{PP} = 12.75 \text{ V} \pm 0.25 \text{ V}$	0.095	0.1	0.105	ms

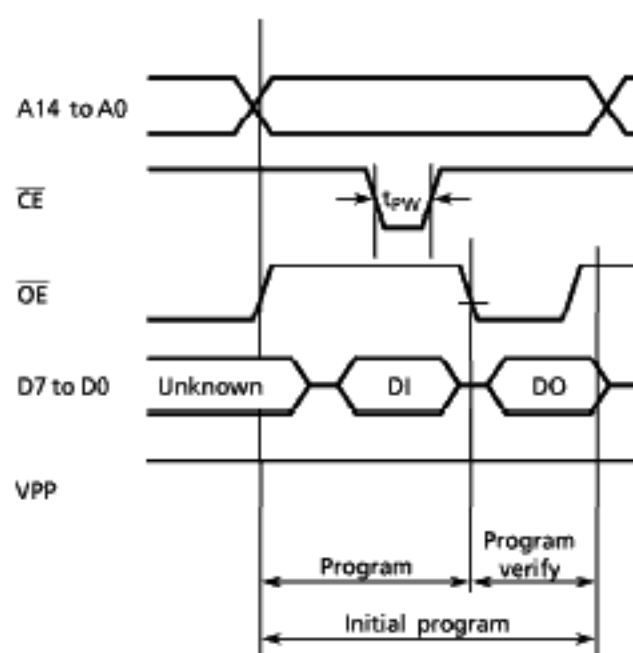

Note: DO ; Data output (I0 to I7)
DI ; Data input (I0 to I7)

Note 1: When V_{CC} power supply is turned on or after, V_{PP} must be increased.

When V_{CC} power supply is turned off or before, V_{PP} must be decreased.

Note 2: The device must not be set to the EPROM programmer or picked up from it under applying the program voltage ($12.75 \text{ V} \pm 0.25 \text{ V}$) to the V_{PP} pin as the device is damaged.

Note 3: Be sure to execute the recommended programming mode with the recommended programming adaptor. If a mode or an adaptor except the above, the misoperation sometimes occurs.