

TOSHIBA Bipolar Linear Integrated Circuit Silicon Monolithic

TA2157F, TA2157FN

Digital Servo Head Amp for CD System

TA2157F/FN is a digital servo head amp for a 3-beam pickup used in CD systems.

Gain for RF signal generation amp can be freely set, supporting CD-RW.

Combining with single-chip processor TC94A14F/FA/FB, a CMOS digital servo, makes configuring CD systems simple.

Features

- Low power dissipation digital servo head amp
- Built-in amplifier for generating reference voltage (VRO)
- Built-in auto laser power control (APC) amplifier
- Built-in RF amplifier
- Built-in RF signal automatic gain control (AGC) amplifier
- Built-in gain change circuit for CD-RW
- Built-in focus error and tracking error signal amplifiers
- Built-in track count signal amplifier
- Normal-, double-, and $\times 4$ -speed operation
- 24-pin mini flat package

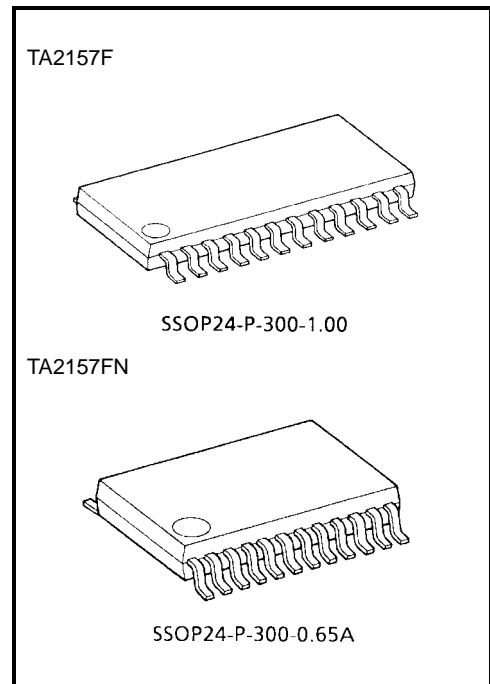

Weight

SSOP24-P-300-1.00: 0.3 g (typ.)

SSOP24-P-300-0.65A: 0.17 g (typ.)

Block Diagram

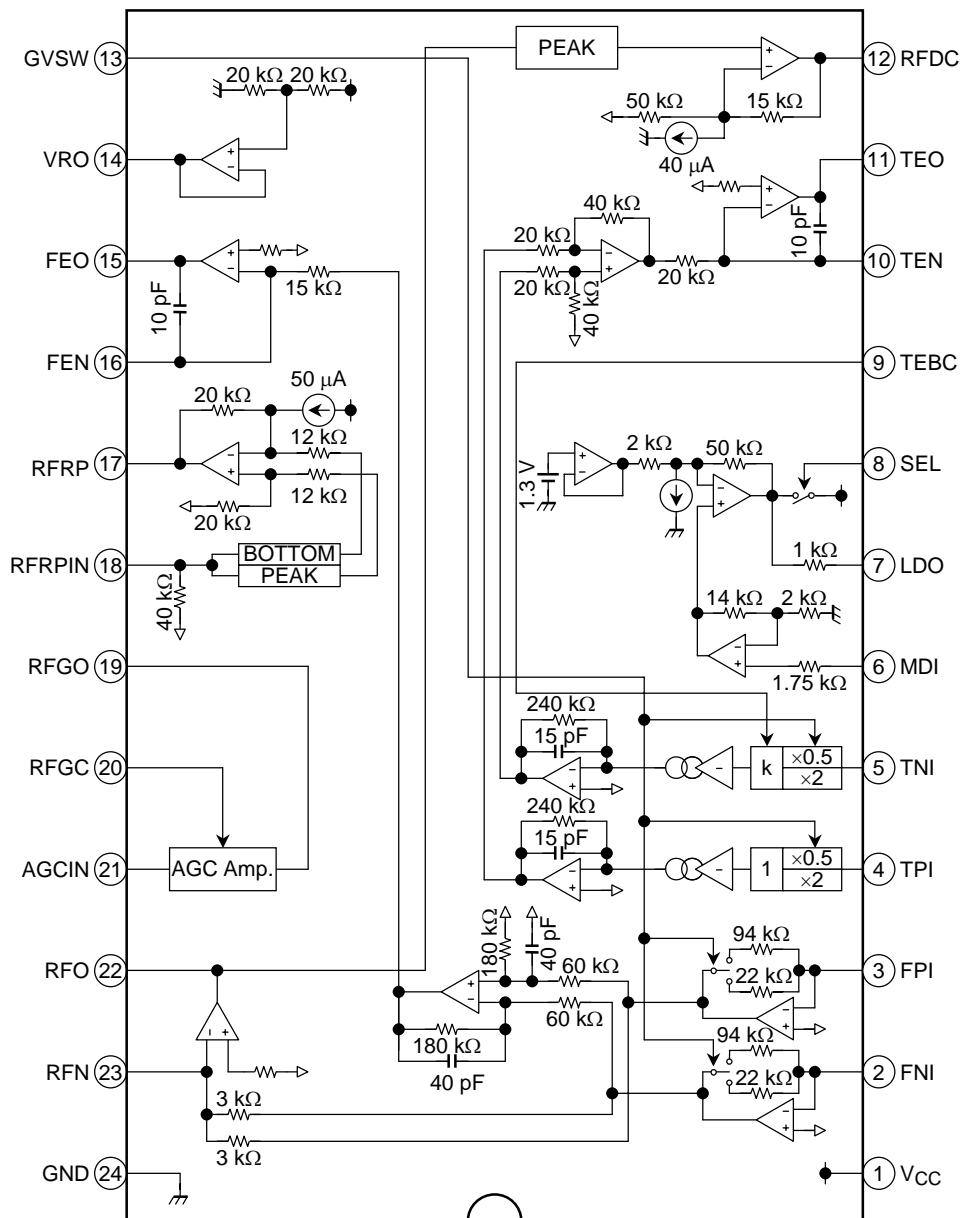

PIN V _{CTRL}	SEL (APC SW)	TEB (TE BAL)	RFGC (AGC Gain)	GVSW
V _{CC}	APC ON	-50%	+12dB	Normal mode (0dB)
HiZ	APC ON	0%	+6dB	Normal mode (0dB)
GND	APC OFF (LDO = H)	+50%	0dB	CD-RW mode (+12dB)

Pin Function

Pin No.	Symbol	I/O	Function Description	Internal Circuit												
1	V _{CC}	—	3.3 V power supply pin	—												
2	FNI	I	Main-beam amp input pin													
3	FPI	I	Main-beam amp input pin													
4	TPI	I	Sub-beam amp input pin													
5	TNI	I	Sub-beam amp input pin													
6	MDI	I	Monitor photo diode amp input pin													
7	LDO	O	Laser diode amp output pin	<p>ON: LD-OFF OFF: LD-ON</p>												
8	SEL	I	APC circuit ON/OFF control signal, laser diode (LDO) control signal input or bottom/peak detection frequency change pin.	<table border="1"> <thead> <tr> <th>SEL</th> <th>APC Circuit</th> <th>LDO</th> </tr> </thead> <tbody> <tr> <td>GND</td> <td>OFF</td> <td>Connected to V_{CC} through 1 kΩ resistor</td> </tr> <tr> <td>HiZ</td> <td>ON</td> <td>Control signal output</td> </tr> <tr> <td>V_{CC}</td> <td>ON</td> <td>Control signal output</td> </tr> </tbody> </table>	SEL	APC Circuit	LDO	GND	OFF	Connected to V _{CC} through 1 kΩ resistor	HiZ	ON	Control signal output	V _{CC}	ON	Control signal output
SEL	APC Circuit	LDO														
GND	OFF	Connected to V _{CC} through 1 kΩ resistor														
HiZ	ON	Control signal output														
V _{CC}	ON	Control signal output														

Pin No.	Symbol	I/O	Function Description	Internal Circuit						
9	TEBC	I	Tracking error balance adjustment signal input pin Adjusts TE signal balance by eliminating carrier component from PWM signal (3-state output, PWM carrier = 88.2 kHz) output from TC94A14F/FA/FB TEBC pin using RC-LPF and inputting DC. TEBC input voltage: GND~V _{CC}							
10	TEN	I	Tracking error signal generation amp negative-phase input pin							
11	TEO	O	Tracking error signal generation amp output pin. Combining TEO signal and RFRP signal with TC94A14F/FA/FB configures tracking search system.							
12	RFDC	O	RF signal peak detection output pin							
13	GVSW	I	AGC/FE/TE amp gain change pin <table border="1" style="margin-left: auto; margin-right: auto;"> <thead> <tr> <th>GVSW</th> <th>Mode</th> </tr> </thead> <tbody> <tr> <td>GND</td> <td>CD-RW</td> </tr> <tr> <td>V_{CC}</td> <td>Normal</td> </tr> </tbody> </table>	GVSW	Mode	GND	CD-RW	V _{CC}	Normal	
GVSW	Mode									
GND	CD-RW									
V _{CC}	Normal									

Pin No.	Symbol	I/O	Function Description	Internal Circuit
14	VRO	O	Reference voltage (VRO) output pin <ul style="list-style-type: none"> VRO = 1/2 V_{CC} when V_{CC} = 3.3 V 	
15	FEO	O	Focus error signal generation amp output pin	
16	FEN	I	Focus error signal generation amp negative-phase input pin	
17	RFRP	O	Signal amp output pin for track count Combining RFRP signal and TEO signal with TC94A14F/FA/FB configures tracking search system.	
18	RFRPIN	I	Signal generation amp input pin for track count	

Pin No.	Symbol	I/O	Function Description	Internal Circuit
19	RFGO	O	RF signal amplitude adjustment amp output pin	
20	RFGC	I	RF amplitude adjustment control signal input pin Adjusts RF signal amplitude by eliminating carrier component from PWM signal (3-state output, PWM carrier = 88.2 kHz) output from TC94A14F/FA/FB RFGC pin using RC-LPF and inputting DC. • RFGC input voltage : GND~V _{CC}	
21	AGCIN	I	RF signal amplitude adjustment amp input pin	
22	RFO	O	RF signal generation amp output pin	
23	RFN	I	RF signal generation amp input pin	
24	GND	—	GND pin	—

Maximum Ratings (Ta = 25°C)

Characteristics		Symbol	Rating	Unit
Supply voltage		V _{CC}	5	V
Power dissipation	TA2157F	P _D	600	mW
	TA2157FN		500	
Operating temperature		T _{opr}	-40 ~ +85	°C
Storage temperature		T _{stg}	-55 ~ +150	°C

Note 1: TA2157F: Derated above 25°C in the proportion 4.76 mW/°C.

TA2157FN: Derated above 25°C in the proportion 4 mW/°C.

Electrical Characteristics (unless otherwise specified, V_{CC} = 3.3 V, V_{RO} = 1.65 V, Ta = 25°C, R_{FGC} = V_{RO}, G_{VS}W = V_{CC})

Characteristics		Symbol	Test Circuit	Test Condition	Min	Typ.	Max	Unit	
Power supply	Assured power supply voltage	V _{CC}	—	—	3.0	3.3	3.6	V	
	Power supply current (normal mode)	I _{CC1}	—	SEL = HiZ TEBC = HiZ RFGC = HiZ	G _{VS} W = V _{CC}	13	19	25	mA
	Power supply current (CD-RW mode)	I _{CC2}			G _{VS} W = GND	12	18	24	
Reference voltage	Reference voltage	V _{RO}	—	When V _{CC} = 3.3 V	1.55	1.65	1.75	V	
	Output current	I _{OH}	—	ΔV = -0.1 V	3	—	—	mA	
	Input current	I _{OL}	—	ΔV = +0.1 V	3	—	—		
APC MD → LDO	Voltage gain	G _{VAPC}	—	f = 1 kHz	—	200	—	V/V	
	Operating reference voltage	V _{MDI}	—	V _{LDO} = V _{CC} - 1.3 V	170	178	186	mV	
	LD off voltage	V _{LDOP}	—	V _{CC} reference, SEL = GND	-0.75	-0.7	—	V	
	Input bias current	I _{IAPC}	—	V _{MDI} = 178 mV	-200	-50	0	nA	
RF FPI (FNI) → RFO	Transfer resistance 1 (normal mode)	R _{t1RF}	—	f = 100 kHz R _f = 12 kΩ	G _{VS} W = V _{CC}	74	85	95	kΩ
	Transfer resistance 2 (CD-RW mode)	R _{t2RF}			G _{VS} W = GND	325	370	414	
	Frequency characteristic 1 (normal mode)	f _{C1RF}	—	-3dB point R _f = 12 kΩ	G _{VS} W = V _{CC}	—	13	—	MHz
	Frequency characteristic 2 (CD-RW mode)	f _{C2RF}			G _{VS} W = GND	—	8	—	
	Output slew rate	S _{RRF}	—	C _{RFO} = 20 pF	—	35	—	V/μs	
	Upper limit output voltage	V _{OHRF}	—	GND reference	—	2.2	2.4	—	V
	Lower limit output voltage	V _{OLRF}			—	0.2	0.4		
	Permissive load resistance	R _{LMRF}	—	—	—	5	10	—	kΩ

Characteristics		Symbol	Test Circuit	Test Condition	Min	Typ.	Max	Unit	
AGC AGCI → RFGO	Voltage gain 1	G _{V1AG}	—	f = 1 MHz	RFGC = GND	-1.5	-0.5	0.5	dB
	Voltage gain 2	G _{V2AG}			RFGC = HiZ	5.5	6.5	7.5	
	Voltage gain 3	G _{V3AG}			RFGC = V _{CC}	12	13.5	15	
	Frequency characteristic 1	f _{C1AG}	—	-3dB point	RFGC = GND	—	15	—	MHz
	Frequency characteristic 2	f _{C2AG}			RFGC = HiZ	—	15	—	
	Frequency characteristic 3	f _{C3AG}			RFGC = V _{CC}	—	15	—	
	Output slew rate	SR _{AG}	—	C _{RFO} = 20 pF		—	25	—	V/μs
	Upper limit output voltage	V _{OHAG}	—	GND reference		2.2	2.4	—	V
	Lower limit output voltage	V _{OLAG}				—	0.2	0.4	
	Permissible load resistance	R _{LMAG}	—	—		5	10	—	kΩ
FE FPI (FNI) → FEO	Transfer resistance 1 (normal mode)	R _{t1FE}	—	f = 1 kHz R _{FIN} = 47 kΩ R _{FEFB} = 33 kΩ	G _{VSW} = V _{CC}	127	145	162	kΩ
	Transfer resistance 2 (CD-RW mode)	R _{t2FE}			G _{VSW} = GND	545	620	694	
	Gain balance 1 (normal mode)	GB _{1FE}	—	G _{VSW} = V _{CC} , ΔR _{t1FE}		-1	0	+1	dB
	Gain balance 2 (CD-RW mode)	GB _{2FE}		G _{VSW} = GND, ΔR _{t2FE}		-1	0	+1	
	Frequency characteristic 1 (normal mode)	f _{C1FE}	—	-3dB point R _{FEFB} = 33 kΩ	G _{VSW} = V _{CC}	—	20	—	kHz
	Frequency characteristic 2 (CD-RW mode)	f _{C2FE}			G _{VSW} = GND	—	20	—	
	Output offset voltage 1 (normal mode)	V _{OS1FE}	—	VRO reference FPI/FNI open	G _{VSW} = V _{CC}	-50	0	+50	mV
	Output offset voltage 2 (CD-RW mode)	V _{OS2FE}			G _{VSW} = GND	-100	0	+100	
	Upper limit output voltage	V _{OHFE}	—	GND reference		2.9	3.1	—	V
	Lower limit output voltage	V _{OLFE}				—	0.1	0.3	
	Permissible load resistance	R _{LMFE}	—	—		5	10	—	kΩ

Characteristics		Symbol	Test Circuit	Test Condition	Min	Typ.	Max	Unit		
TE TPI (TNI) → TEO	Transfer resistance 1 (normal mode)	Rt1TE	—	f = 1 kHz TE _{RFB} = 39 kΩ RTIN = 47 kΩ TEBC = HiZ	GVSW = V _{CC}	411	468	525	kΩ	
	Transfer resistance 2 (CD-RW mode)	Rt2TE		GVSW = GND	1647	1872	2092			
	Gain balance adjustment width	H (DA)	ΔRt1	—	GVSW = V _{CC}	TEBC = GND	+40	+50	+60	%
		L (DA)	ΔRt2			TEBC = V _{CC}	-60	-50	-40	
	Gain balance 1 (normal mode)	GB1TE	—	GVSW = V _{CC} , ΔRt1FE		-1	0	+1	dB	
	Gain balance 2 (CD-RW mode)	GB2TE		GVSW = GND, ΔRt2FE		-1	0	+1		
	Frequency characteristic 1 (normal mode)	f _{C1TE}	—	-3dB point R _{TEFB} = 39 kΩ	GVSW = V _{CC}	—	40	—	kHz	
	Frequency characteristic 2 (CD-RW mode)	f _{C2TE}			GVSW = GND	—	40	—		
	Output offset voltage 1 (normal mode)	V _{OS1TE}	—	VRO reference TPI/TNI open	GVSW = V _{CC}	-50	0	+50	mV	
	Output offset voltage 2 (CD-RW mode)	V _{OS2TE}			GVSW = GND	-150	0	+150		
	Upper limit output voltage	V _{OHTE}	—	GND reference		2.9	3.1	—	V	
	Lower limit output voltage	V _{OLTE}				—	0.1	0.3		
	Permissible load resistance	R _{LMTE}	—	—		5	10	—	kΩ	
RFDC FNI (FPI) → RFDC	Detection frequency	f _{DC}	—	-3dB point at low-frequency with output amplitude = 0dB when RFO = 1.2 V _{pp} /350 kHz in relation to V _{OP1DC}	—	15	—	kHz		
	Operating reference voltage 1	V _{OP1DC}	—	FNI/FPI open, VRO reference, RFN-V _{cc} = 47 kΩ	-0.15	0	0.15	V		
	Operating reference voltage 2	V _{OP2DC}		VRO reference, RFO = 1.2 V _{pp} /350 kHz RFN-V _{cc} = 47 kΩ	0.6	0.75	0.9			
	Upper limit output voltage	V _{OHDC}	—	GND reference		2.9	3.1	—	V	
	Lower limit output voltage	V _{OLDC}				—	0.3	0.5		
	Permissible load resistance	R _{LMDC}	—	—		5	10	—	kΩ	
RFRP RFRPIN → RFRP	Voltage gain	G _{VRP}	—	AMP gain after detection	—	4.4	—	dB		
	Detection frequency	f _{CRP}	—	-3dB point at low-frequency with output amplitude = 0dB when RFO = 1.2 V _{pp} /700 kHz in relation to V _{OP1RP}	—	35	—	kHz		
	Detection time constant	T _{RP}	—	1.2 V _{pp} /5 kHz square wave (C _{in} > 1 μF)	—	37	—	V/ms		
	Operating reference voltage 1	V _{OP1RP}	—	VRO reference, no input	-1.0	-0.85	-0.7	V		
	Operating reference voltage 2	V _{OP2RP}		VRO reference, RFO = 700 kHz, 1.2 V _{pp}	0.7	0.85	1.0			
	Upper limit output voltage	V _{OHRP}	—	GND reference		2.9	3.1	—	V	
	Permissible load resistance	R _{LMRP}	—	—		5	10	—	kΩ	

Note 2: (DA) : Normal mode

Note 3: If the IC is used abnormally (ex, wrongly mounted), it may be damaged or destroyed.

Test Methods (supplementary)

Note: Due to the relation with RFRP detection frequency, use feed search (track cross speed) at 80 kHz or less.

1. Test method for RFRP detection frequency characteristic and detection time constant

(1) Detection frequency

Set to 0dB the maximum output amplitude of the RFRP pin in relation to the operating reference voltage 1 (V_{OP1RP}) when the sine wave shown in the figure below is input via a capacitor ($C_{in} > 1 \mu F$) to the RFRPIN pin and specify a frequency whose amplitude is $-3dB$.

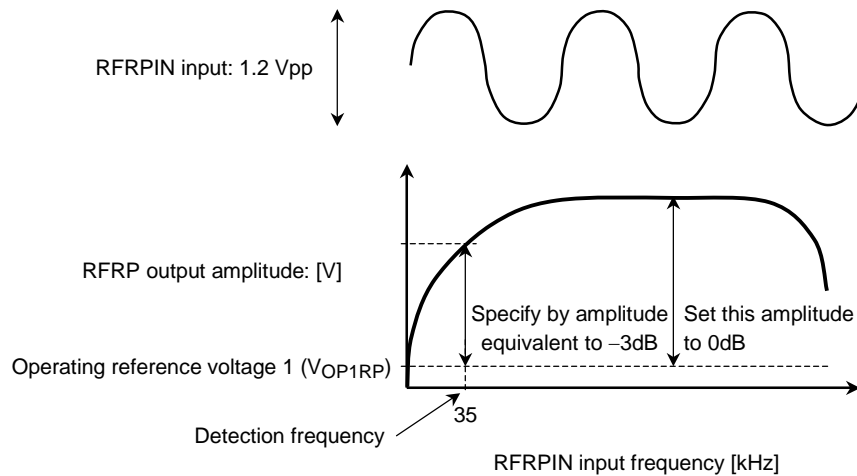

(2) Detection time constant

Specify the time constant for peak and bottom detection frequencies when the square wave shown in the figure below is input via a capacitor ($C_{in} > 1 \mu F$) to the RFRPIN pin at the slew rate of the RFRP pin output sawtooth wave.

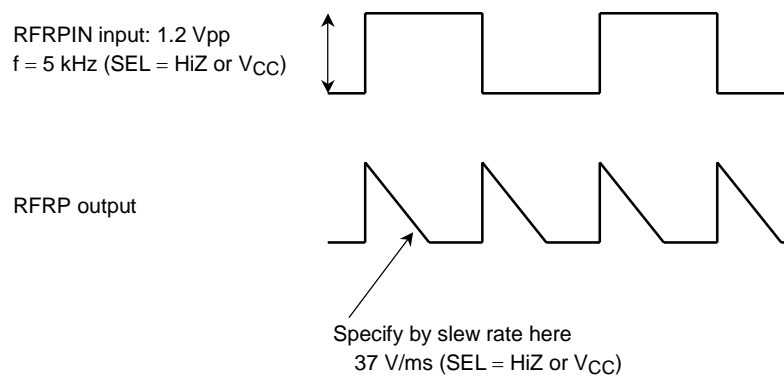

Test Circuit

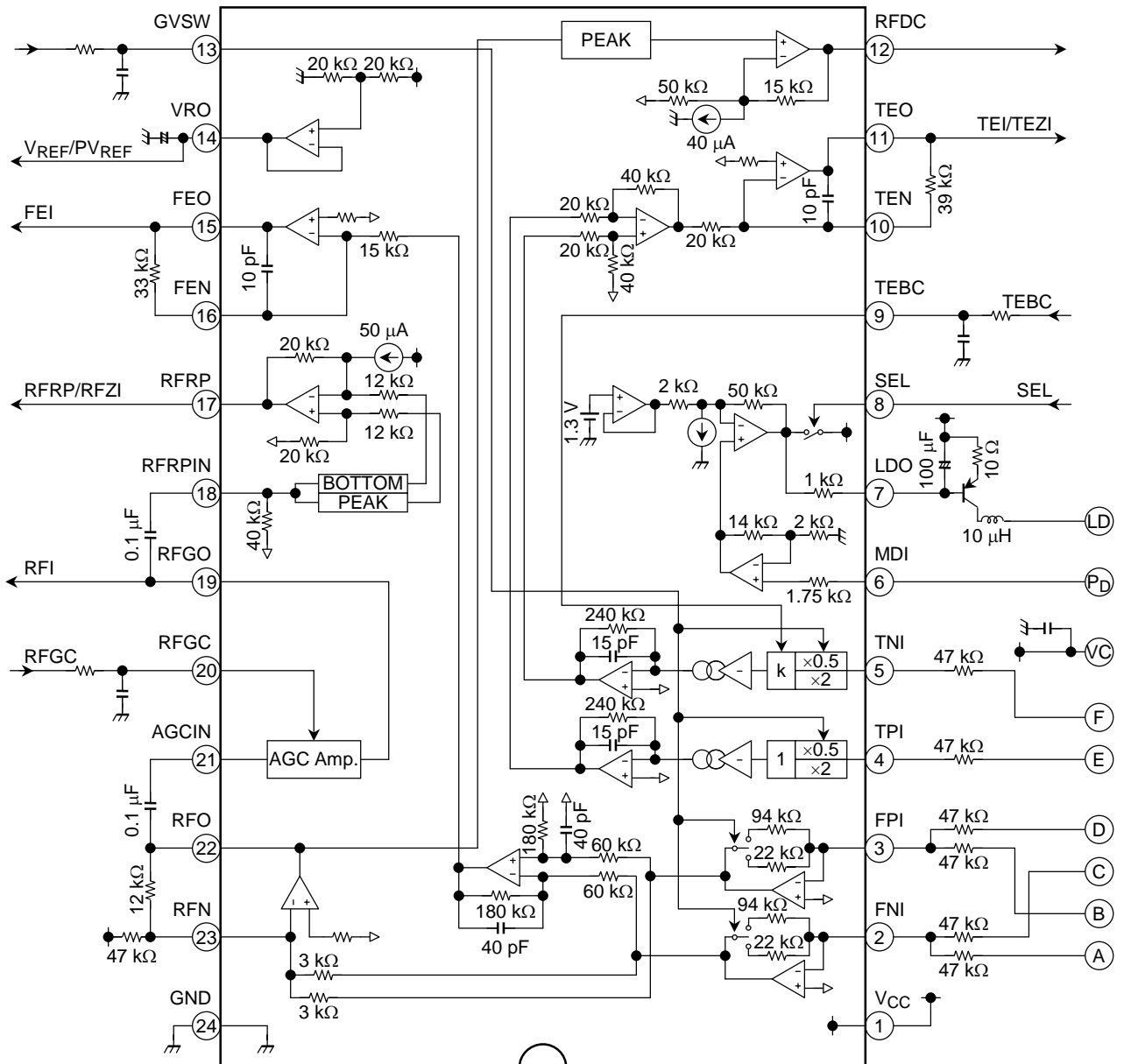

Package Dimensions

SSOP24-P-300-1.00

Unit : mm

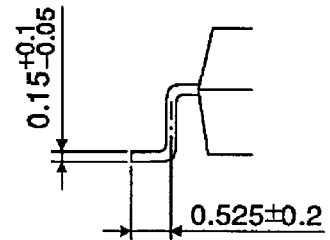
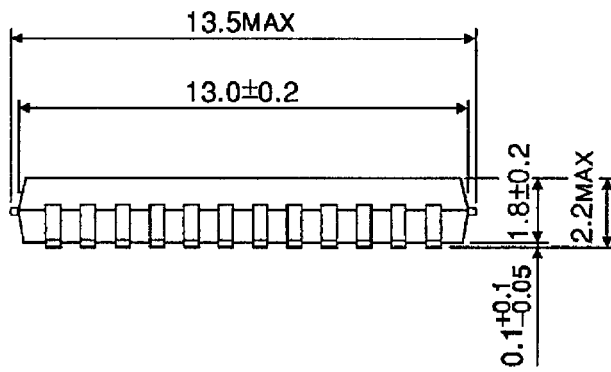
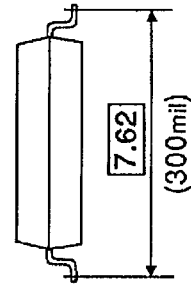
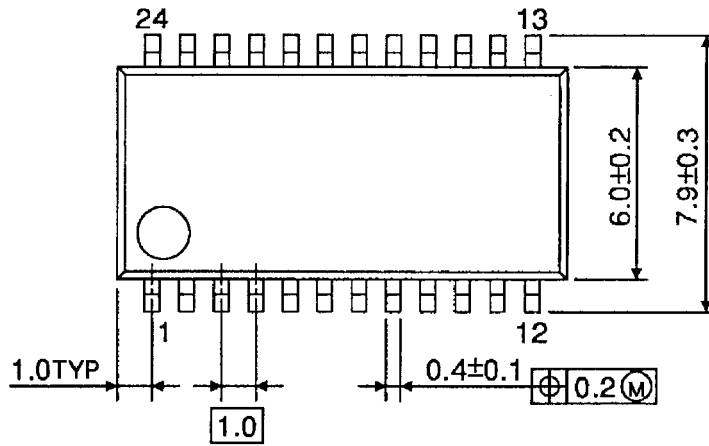

Weight: 0.3 g (typ.)

Package Dimensions

SSOP24-P-300-0.65A

Unit : mm

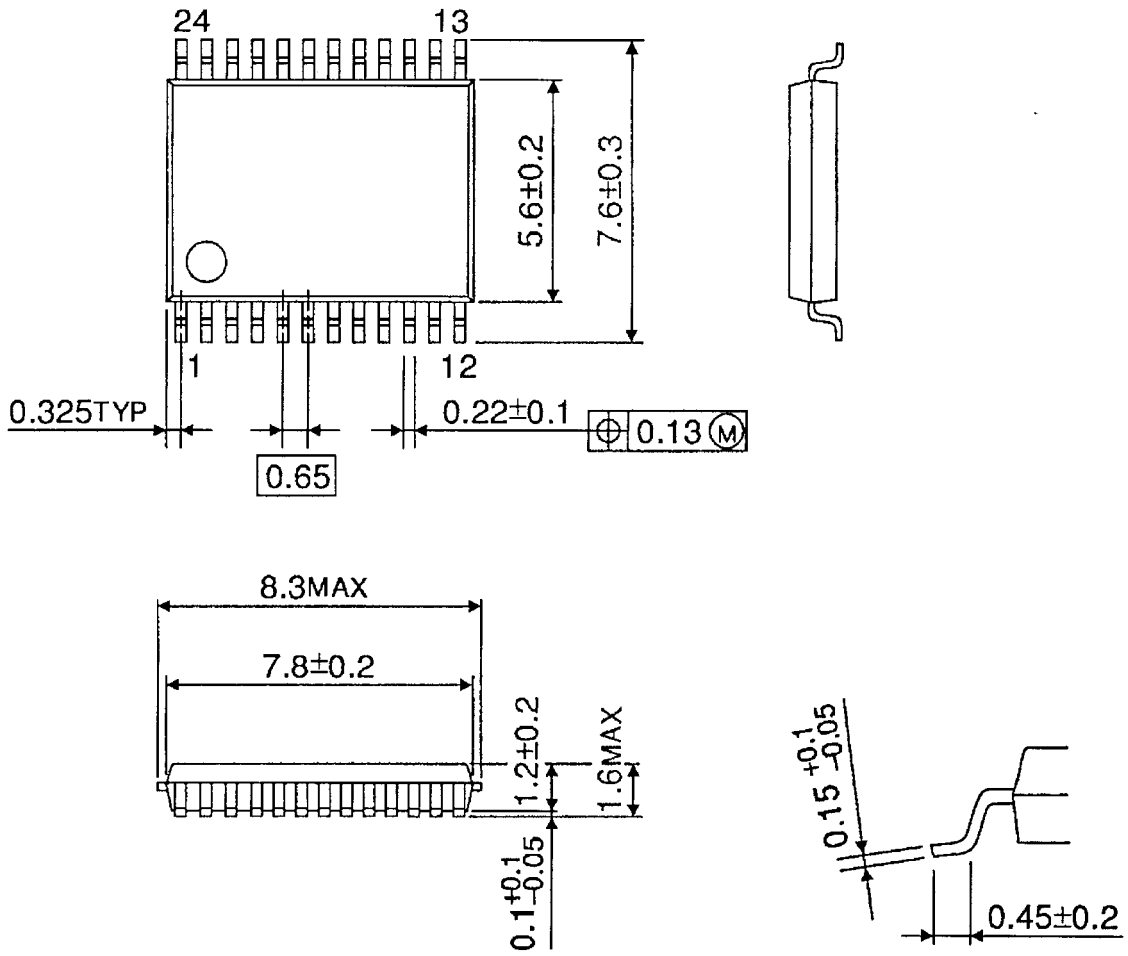

Weight: 0.17 g (typ.)

RESTRICTIONS ON PRODUCT USE

000707EBA

- TOSHIBA is continually working to improve the quality and reliability of its products. Nevertheless, semiconductor devices in general can malfunction or fail due to their inherent electrical sensitivity and vulnerability to physical stress. It is the responsibility of the buyer, when utilizing TOSHIBA products, to comply with the standards of safety in making a safe design for the entire system, and to avoid situations in which a malfunction or failure of such TOSHIBA products could cause loss of human life, bodily injury or damage to property.
In developing your designs, please ensure that TOSHIBA products are used within specified operating ranges as set forth in the most recent TOSHIBA products specifications. Also, please keep in mind the precautions and conditions set forth in the "Handling Guide for Semiconductor Devices," or "TOSHIBA Semiconductor Reliability Handbook" etc..
- The TOSHIBA products listed in this document are intended for usage in general electronics applications (computer, personal equipment, office equipment, measuring equipment, industrial robotics, domestic appliances, etc.). These TOSHIBA products are neither intended nor warranted for usage in equipment that requires extraordinarily high quality and/or reliability or a malfunction or failure of which may cause loss of human life or bodily injury ("Unintended Usage"). Unintended Usage include atomic energy control instruments, airplane or spaceship instruments, transportation instruments, traffic signal instruments, combustion control instruments, medical instruments, all types of safety devices, etc.. Unintended Usage of TOSHIBA products listed in this document shall be made at the customer's own risk.
- The products described in this document are subject to the foreign exchange and foreign trade laws.
- The information contained herein is presented only as a guide for the applications of our products. No responsibility is assumed by TOSHIBA CORPORATION for any infringements of intellectual property or other rights of the third parties which may result from its use. No license is granted by implication or otherwise under any intellectual property or other rights of TOSHIBA CORPORATION or others.
- The information contained herein is subject to change without notice.

Copyright Each Manufacturing Company.

All Datasheets cannot be modified without permission.

This datasheet has been download from :

www.AllDataSheet.com

100% Free DataSheet Search Site.

Free Download.

No Register.

Fast Search System.

www.AllDataSheet.com