

Sep. 15, '99

No. 3284LTD-1308-1

# HITACHI

## LIQUID CRYSTAL DISPLAY MODULE TECHNICAL DATA

### SX25S003-ZZA

(NOTE)

1. This document may, wholly or partially, be subject to change without notice.
2. All rights are reserved ; No one is permitted to reproduce or duplicate, in any form, the whole or part of this document without Hitachi's permission.
3. No one is permitted to explain contents of this document to third parties without Hitachi's permission.
4. Hitachi will not be held responsible for any damage to the user that may result from accidents or any other reasons during operation of the user's unit according to this document, any previous reports or oral discussions.
5. Circuitry and other examples described herein are meant merely to indicate the characteristics and performance of Hitachi's products. Hitachi assumes no responsibility for any intellectual property claims or other problems that may result from applications based on the examples described herein.
6. No license is granted by implication or otherwise under any patents or other rights of any third party or Hitachi, Ltd.
7. LIFE SUPPORT APPLICATIONS : Hitachi's products are not authorized for use in LIFE SUPPORT SYSTEMS.

RECORD OF REVISION

Date	Sheet No.	Summary

### 3. MECHANICAL DATA

(1) Part Name	SX25S003-ZZA
(2) Module Size	236.0(W) mm × 168.0(H) mm × 7.9 max (D) mm
(3) Display Size	Diagonal size 25cm (10.0")
(4) Dot Pitch	0.0845(W) mm × 0.2535(H) mm
(5) Number of Dots	800 × 3 (R,G,B)(W) × 600 (H) dots
(6) Duty	1/300
(7) LCD	Film type (negative type)
(8) View ing Direction	12 O'clock
(9) Backlight	Cold Cathode Fluorescent Lamp (CFL) × 2
(10) Weight	(442)g typ
(11) Pow er Supply Voltage	3.3V only
(12) Touch Panel	Resistance Type

#### 4. ABSOLUTE MAXIMUM RATINGS

##### 4. 1 ELECTRICAL ABSOLUTE MAXIMUM RATINGS (LCM)

VSS=0V:Standard

ITEM	SYMBOL	MIN	MAX	UNIT	COMMENT
Power Supply for Logic	VDD-VSS	0	4.6	V	
Contrast Adjustment Voltage	VCON-VSS	0	VDD	V	
Input Voltage	$V_i$	-0.3	VDD+0.3	V	Note 1
Input Current	$i_i$	0	1	A	
Static Electricity	-	-	-	-	Note 2

Note 1  $\overline{\text{DISP OFF}}$ , FLM, CL1, CL2, UD0-UD7, LD0-LD7

Note 2 Make certain you are grounded when handling LCM

##### 4. 2 ELECTRICAL ABSOLUTE MAXIMUM RATINGS (TOUCH PANEL)

ITEM	SPECIFICATION	NOTE
Voltage	(7VDC) (max)	
Current	(25mA) (max)	

##### 4. 3 ENVIRONMENTAL ABSOLUTE MAXIMUM RATINGS

ITEM	OPERATING		STORAGE		COMMENT
	MIN	MAX	MIN	MAX	
Ambient Temperature	5°C	40°C	-20°C	60°C	Note 2, 3
Humidity	Note 1		Note 1		Without condensation
Vibration	-	2.45 m/s <sup>2</sup> (0.25G)	-	11.76 m/s <sup>2</sup> (1.2G) Note 5	Note 4
Shock	-	29.4 m/s <sup>2</sup> (3G)	-	490 m/s <sup>2</sup> (50G) Note 5	XYZ directions 11ms
Corrosive Gas	Not Acceptable		Not Acceptable		

Note 1  $T_a \leq 40^\circ\text{C}$  : 85%RH max.

$T_a > 40^\circ\text{C}$  : Absolute humidity must be lower than the humidity of 85%RH at 40°C.

Note 2  $T_a$  at -20°C ----- <48h, at 60°C ----- <168h

Note 3 Background color changes slightly depending on ambient temperature.  
This phenomenon is reversible.

Note 4 5Hz~100Hz (Except resonance frequency)

Note 5 This module should be operated normally after finish the test.

Note 6 When LCM is operated at 5°C, the life time of CFL will be reduced.  
Need to make sure of value of IL and characteristics of inverter.  
Also the response time at 5°C will be slower.

## 5. ELECTRICAL CHARACTERISTICS

### 5. 1 ELECTRICAL CHARACTERISTICS OF LCD

VSS=0V

ITEM	SYMBOL	CONDITION	MIN	TYP	MAX	UNIT
Power Supply Voltage	VDD	VDD-VSS=3.3V	3.15	3.30	3.45	V
Contrast Adjustment Voltage (Note 1)	VCON	-	1.2	-	2.4	V
Input Voltage for Logic Circuits (Note 2)	Vi	"H" level	0.8VDD	-	VDD	V
		"L" level	0	-	0.2VDD	
Power Supply Current (Note 3)(Note 6)	IDD	VDD-VSS=3.3V	-	120	200	mA
Input Leak Current	I <sub>con</sub> (Note4)	V <sub>con</sub> =0.8~2.8V	-	-	(20)	μA
	I <sub>in</sub> (Note2)	V <sub>in</sub> =VDDorVSS	-	-	±1.0	
Contrast Adjustment Voltage (Note 7)	V <sub>con</sub>	T <sub>a</sub> = 5°C, φ=0°	1.2	-	-	V
		T <sub>a</sub> =25°C, φ=0°	1.5	1.9	2.3	
		T <sub>a</sub> =40°C, φ=0°	-	-	2.4	
Frame Frequency (Note 5)	fFLM	-	70	120	130	Hz

(Note 1) In proportion as the VCON voltage decrease the brightness will increase.

(Note 2) DISP OFF, FLM, CL1, CL2, UD0~UD7, LD0~LD7

(Note 3) fFLM=120Hz, T<sub>a</sub>=25°C, Display pattern:Checker pattern.

(Note 4) VCON

(Note 5) Need to make sure of flickering and rippling of display when setting the Frame Frequency in your set.

(Note 6) Rush Current of Power ON : 0.8A × 10ms

(Note 7) The Contrast Adjustment Voltage is specified as 1.9±0.4V under the condition, when an optimum contrast is obtained by naked eyes as the "Q" test pattern.

fFLM=120Hz, 1/313Duty

## 5. 2 ELECTRICAL CHARACTERISTICS OF TOUCH PANEL

### 5.2.1 OPERATING CONDITION

ITEM	SPECIFICATION
Operating Voltage	5VDC
Operating Current	10~25mA

### 5.2.2 ELECTRICAL CHARACTERISTICS

ITEM		SPECIFICATION	NOTE
Resistance betw een terminal	X1-X2	350~900Ω	
	Y1-Y2	250~550Ω	
Insulance Resistance	X-Y	10MΩ min	Operating Voltage :25VDC
Linearity	X	1.5% max	See Note 1
	Y	1.5% max	
Chattering		10msec max	

### 5.2.3 MECHANICAL CHARACTERISTICS

ITEM	SPECIFICATION	NOTE
Pen input pressure	0.05N~0.5N	
Surface hardness	2H min	JIS K 5400

### 5.2.4 OPTICAL CHARACTERISTICS

ITEM	SPECIFICATION	NOTE
Transparency	81% typ	

Note 1 : Test Methode and Conditions

The difference ("e") between the theoretical output voltage and the actual output voltage when pressure is applied to any point within the valid area must be as indicated below.

$$e \leq \text{applied voltage} \times 0.03 (\pm 0.015)$$

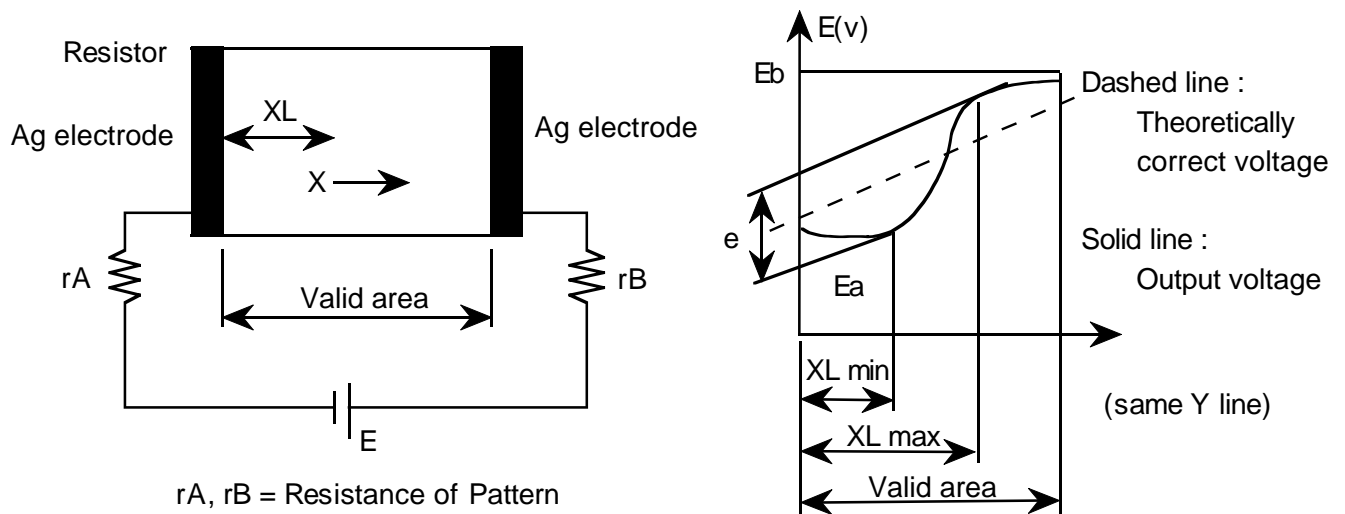

rA, rB = Resistance of Pattern

### 5. 3 ELECTRICAL CHARACTERISTICS OF BACKLIGHT

ITEM	SYMBOL	MIN	TYP	MAX	UNIT	NOTE
Lamp Voltage	VL	-	(500)	-	Vrms	Ta=25°C
Frequency	fL	50	60	-	kHz	
Lamp Current (1Lamp) (Note6)	IL	3.5 (Note 2)	5	5.5 (Note 2)	mA	Ta=25°C
Starting discharge Voltage	VS (Note 2)	(1500)	-	-	Vrms	Ta=5°C

- (Note 1) Please design your lamp driving circuit (inverter) according to the above specifications, and inform Hitachi of it.
- (Note 2) Starting discharge voltage is increased when LCM is operating at lower temperature. Please check the characteristics of your inverter before applying to your set.
- (Note 3) Average life time of CFL will be decreased when LCM is operating at lower temperature.
- (Note 4) Under lower driving frequency of an inverter, a certain backlight system (CFL & CFL reflection sheet) may generate a sound noise. Before designing the inverter, please consider the driving frequency and the noise.
- (Note 5) When ICL is used over 5.5mA, it may cause uneven contrast near CFL location, due to heat dispersion from CFL.

6. OPTICAL CHARACTERISTICS

6.1 OPTICAL CHARACTERISTICS OF LCD

Ta=25°C (Backlight On)

ITEM		SYMBOL	CONDITION	MIN	TYP	MAX	UNIT	NOTE
Viewing area		$\phi 2-\phi 1$	$\theta=0^\circ, K \geq 2.0$	-	(40)	-	deg	1),2)
Contrast ratio		K	$\phi=0^\circ, \theta=0^\circ$	25	50	-	-	3),5),6)
Response time (rise)		tr	$\phi=0^\circ, \theta=0^\circ$	-	170	225	ms	4)
Response time (fall)		tf	$\phi=0^\circ, \theta=0^\circ$	-	130	225	ms	4)
Color tone (Primary Color)	Red	x	$\phi=0^\circ, \theta=0^\circ$	0.48	0.53	0.58	-	7)
		y		0.25	0.30	0.35	-	
	Green	x		0.26	0.31	0.36	-	
		y		0.46	0.51	0.56	-	
	Blue	x		0.11	0.16	0.21	-	
		y		0.09	0.14	0.19	-	
	White	x		0.26	0.31	0.36	-	
		y		0.27	0.32	0.37	-	

(Measurement condition : Hitachi standard)

Note 1)~7) : See next page.



Note 1. Definition of  $\theta$  and  $\phi$

(Normal)

Viewing direction

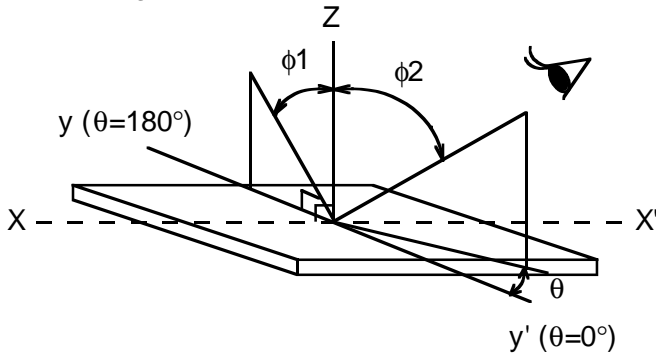

Note 3. Definition of contrast "K"

$$K = \frac{\text{Brightness on selected area (B1)}}{\text{Brightness on non-selected area (B2)}}$$

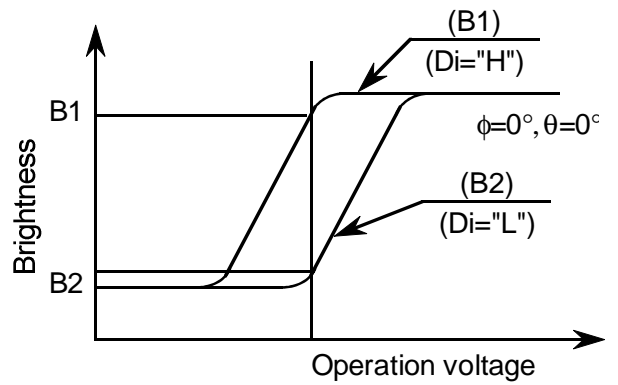

Note 2. Definition of view ing angle  $\phi_1$  and  $\phi_2$

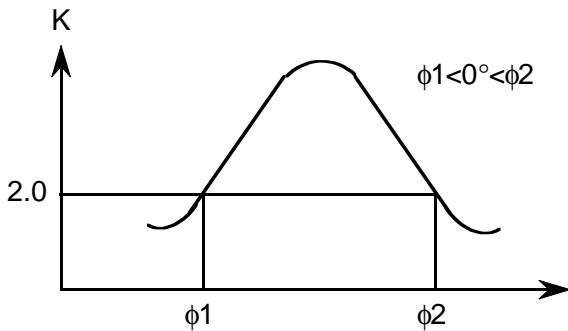

Contrast ratio K vs view ing angle  $\phi$

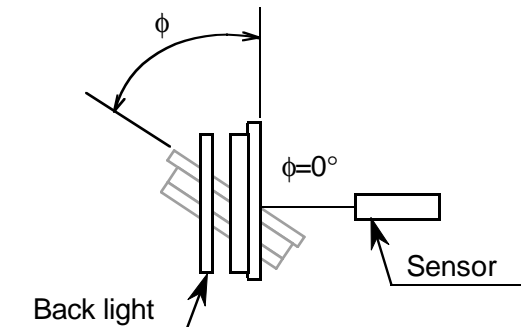

Sensor : BM-7 or correspondence equipment

Note 4. Definition of optical response time

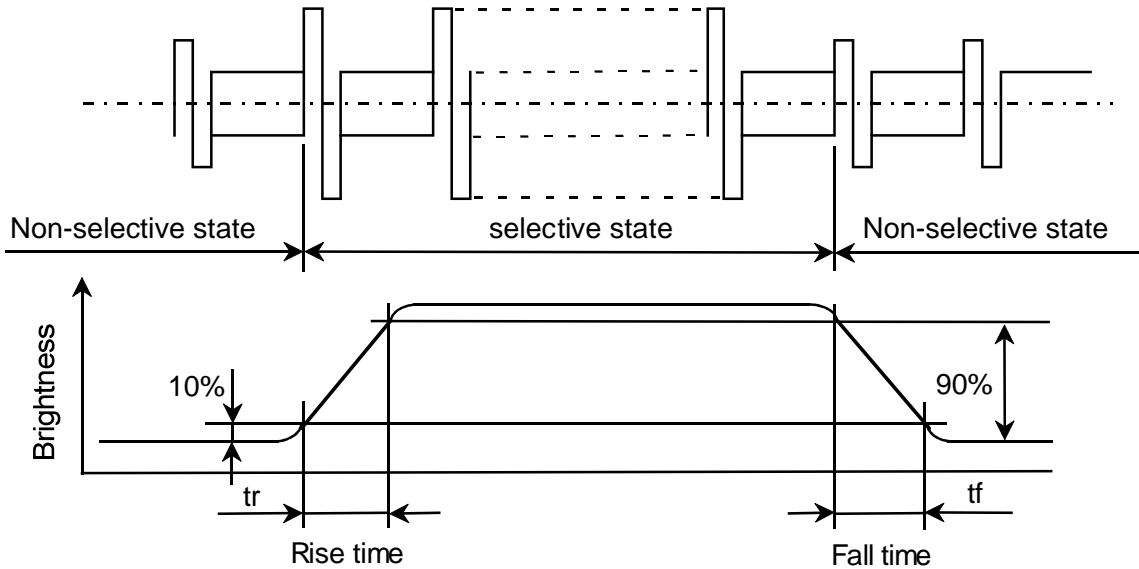

Note 5. Hitachi will not do 100% inspection for minimum value. Minimum value is for reference.

Note 6. Hitachi will do sampling inspection for minimum value.

Note. 7 The LCD driving voltage should be adjusted at the voltage where the peak contrast is obtained.

## 6.2 OPTICAL CHARACTERISTICS OF BACKLIGHT

ITEM	MIN	TYP	MAX	UNIT	NOTE
Brightness	112	160	-	cd/m <sup>2</sup>	IL=5.0mA Note 1),2)
Rise Time	-	5	-	Minute	IL=5.0mA Brightness 80%
Brightness Uniformity	-	-	±30	%	Undermentioned Note 1),4)

(Measurement condition : Hitachi standard)

CFL : INITIAL, Ta=25°C

Display data should be all "ON"

The LCD driving voltage should be adjusted at the voltage where the peak contrast is obtained, when set pattern is all "Q".

(Note 1) Measurement after 10 minutes from CFL operating.

Average value of 5 points (Note 3).

(Note 2) Brightness control : 100%

(Note 3) Measurement of the following 5 places on the display.

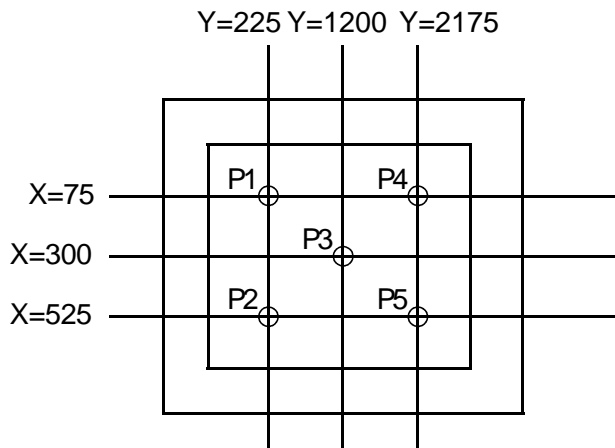

(Note 4) Definition of the brightness tolerance.

$$\left( \frac{\text{Max brightness or Min brightness} - \text{Average brightness}}{\text{Average brightness}} \right) \times 100$$

# 7. BLOCK DIAGRAM

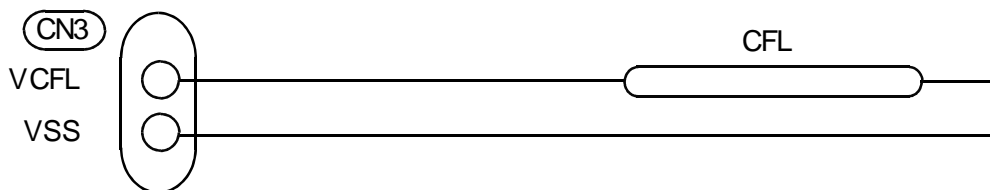
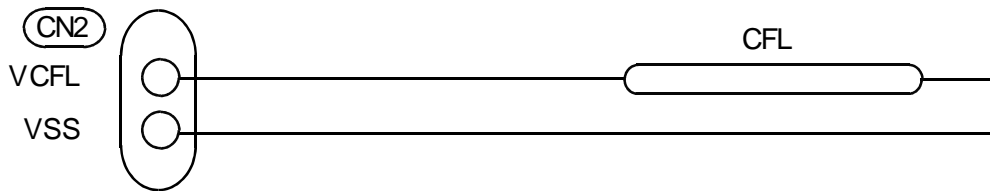
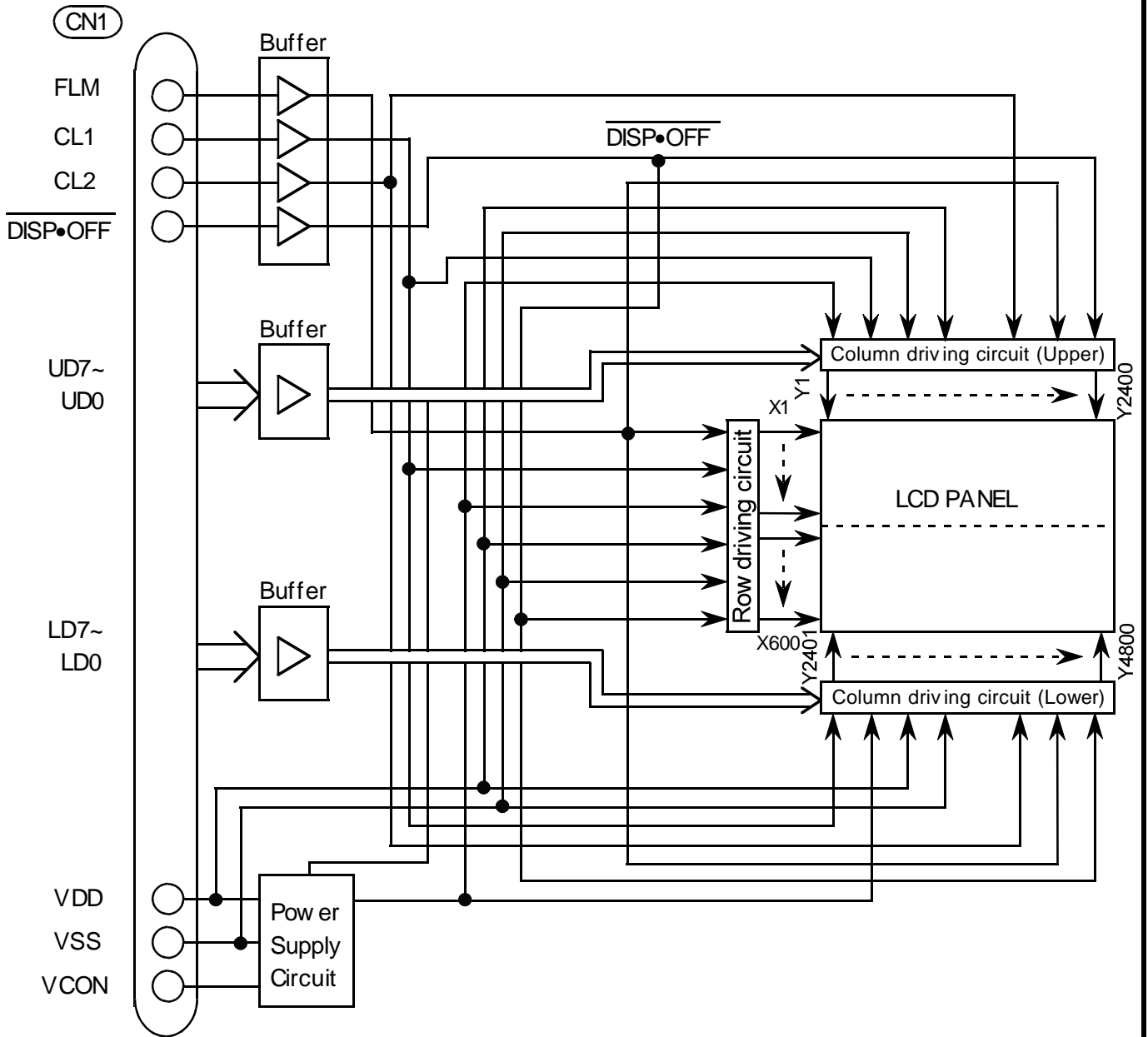

# 8. INTERFACE TIMING CHART

## 8.1 TIMING CHART

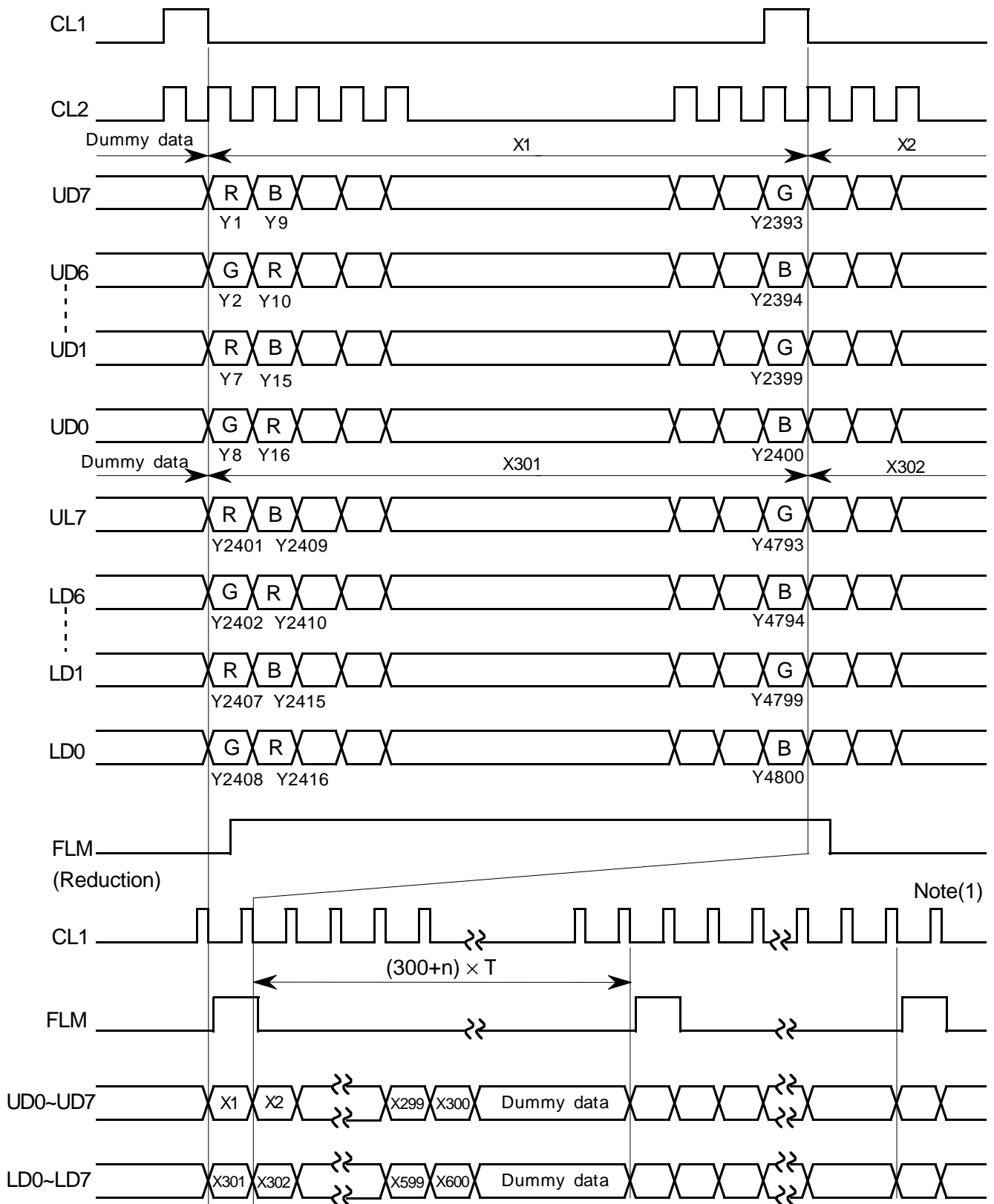

Note(1) : The interval of CL1 pulse must be same including the vertical blanking period.

## 8.2 INTERFACE TIMING SPECIFICATION

VDD=3.3±0.15V, VSS=0V, Vcon=1.2~2.4V, Ta=+5°C~+40°C

ITEM	SYMBOL	MIN	TYP	MAX	UNIT
CL1 pulse width "H"	tWHCL1	150	—	—	ns
Clock cycle time	tCYC	50	—	—	ns
CL2 pulse width	tWCL2	15	—	—	ns
Clock set up time	tSCL1	110	—	—	ns
Clock hold time	tHCL1	110	—	—	ns
Clock rise fall time	tr, tf	—	—	50	ns
Data set up time	tDSU	10	—	—	ns
Data hold time	tDH	10	—	—	ns
"FLM" set up time	tFS	120	—	—	ns
"FLM" hold time	tFH	300	—	—	ns
Set up time	tFSD	120	—	—	ns
Hold time	tFHD	120	—	—	ns

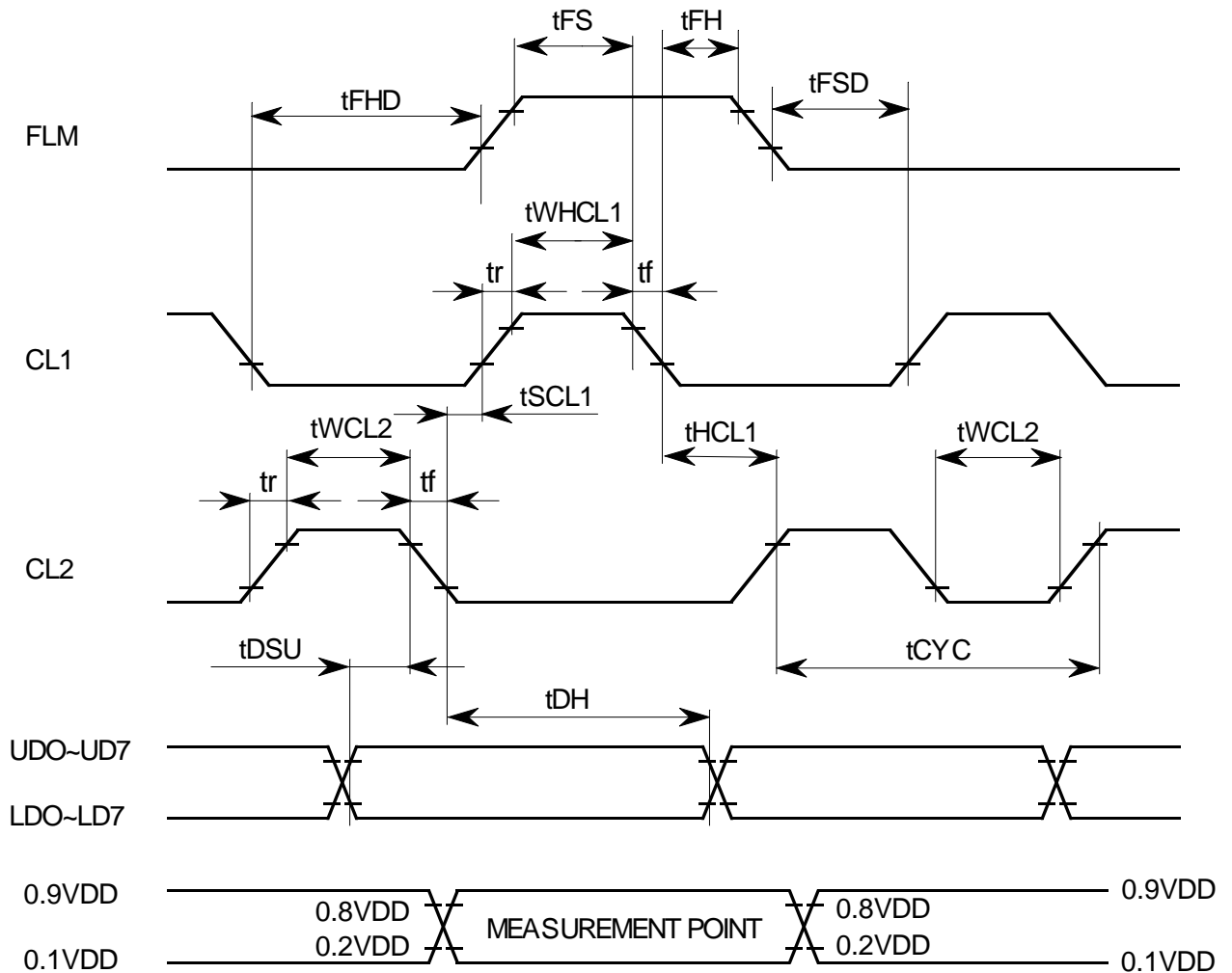

### 8.3 POWER ON / OFF SEQUENCE

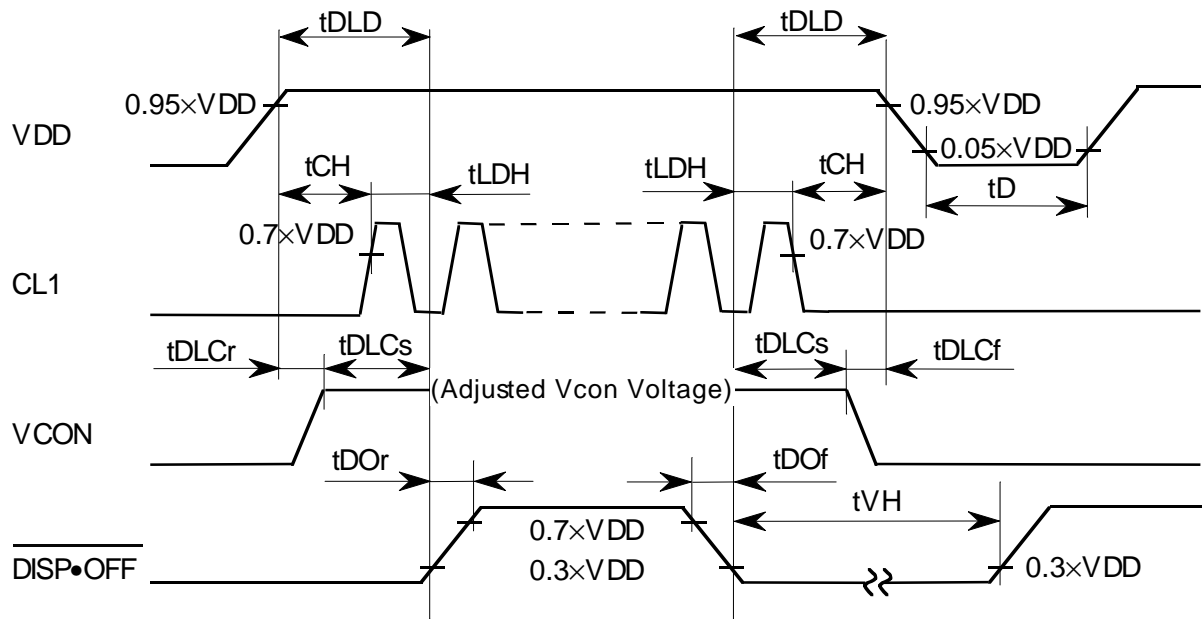

SYMBOL	MIN	MAX	UNIT	COMMENT
tDLD	100		ms	(Note 1)
tCH	0	200	ms	
tLDH	20		ms	
tDOr		100	ns	(Note 2)
tDOF		100	ns	
tDLCr	0		ms	
tDLCf	0		ms	(Note 2, 3)
tDLCs	0		ms	
tVH	200		ms	(Note 4)

(Note 1) Please keep the specified sequence because wrong sequence may cause permanent damage to the LCD panel.

(Note 2) Hitachi recommends you to use DISP•OFF function.  
Display quality may deteriorate if you don't use DISP•OFF function.

(Note 3)  $1.2 \leq V_{con} \leq 2.4V$   
Vcon voltage should be set up to adjusted voltage before DISP•OFF signal arises.  
Otherwise, when DISP•OFF signal arises, adjusted contrast image may not be generated.

(Note 4) Please keep the specified sequence of DISP•OFF signal because if the tVH is short enough, LCD panel may not be restarted.

### 8.4 POWER SUPPLY FOR LCM

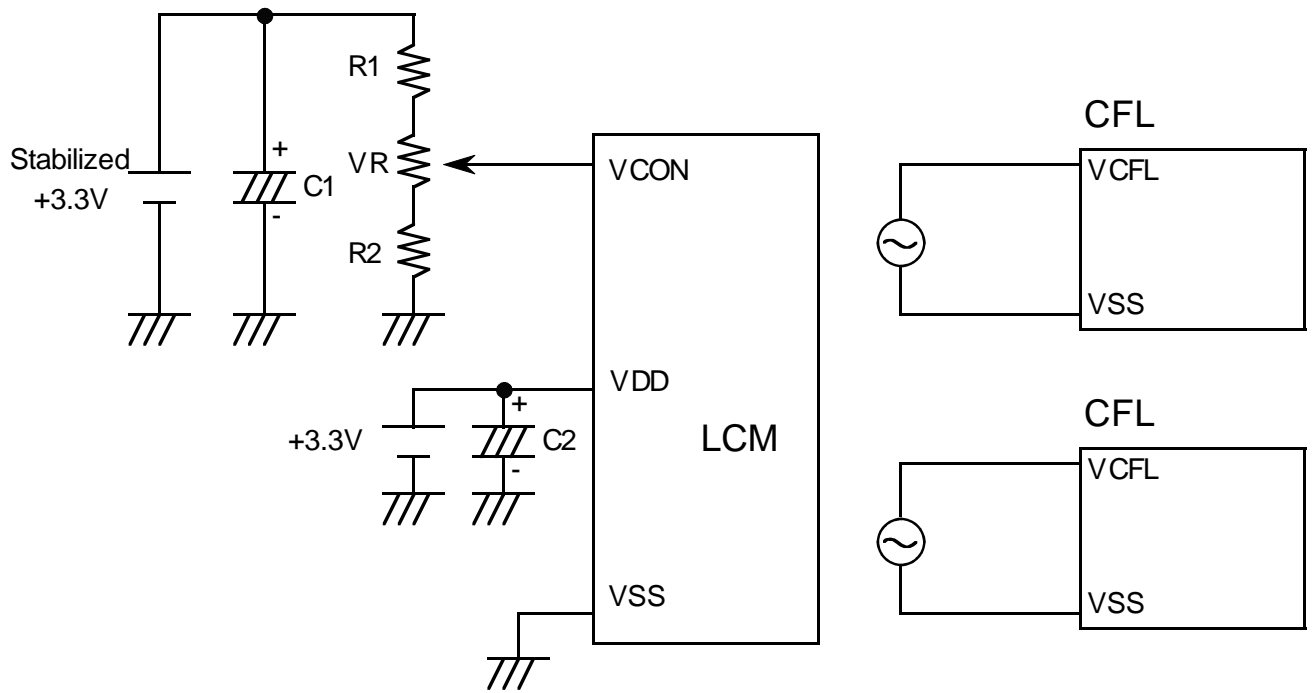

$$R1 + VR + R2 \leq 10k\Omega$$

8.5 INPUT DATA ALLOCATION TABLE

Data Signal	U D 7	U D 6	U D 5	U D 4	U D 3	U D 2	U D 1	U D 0	U D 7	U D 6	U D 5	U D 4	-----	U D 4	U D 3	U D 2	U D 1	U D 0	
Y	1	2	3	4	5	6	7	8	9	10	11	12	-----	2	2	2	2	2	
X														3	3	3	3	4	
		9	9	9	9	9	9	9	9	9	9	9		6	7	8	9	0	
		6	7	8	9	0	0	0	0	0	0	0							
UPPER PANEL	1	R	G	B	R	G	B	R	G	B	R	G	B	-----	G	B	R	G	B
	2	R	G	B	R	G	B	R	G	B	R	G	B	-----	G	B	R	G	B
	3	R	G	B	R	G	B	R	G	B	R	G	B	-----	G	B	R	G	B
	4	R	G	B	R	G	B	R	G	B	R	G	B	-----	G	B	R	G	B
	5	R	G	B	R	G	B	R	G	B	R	G	B	-----	G	B	R	G	B
	⋮	⋮	⋮	⋮	⋮	⋮	⋮	⋮	⋮	⋮	⋮	⋮	⋮		⋮	⋮	⋮	⋮	⋮
	298	R	G	B	R	G	B	R	G	B	R	G	B	-----	G	B	R	G	B
	299	R	G	B	R	G	B	R	G	B	R	G	B	-----	G	B	R	G	B
	300	R	G	B	R	G	B	R	G	B	R	G	B	-----	G	B	R	G	B
	301	R	G	B	R	G	B	R	G	B	R	G	B	-----	G	B	R	G	B
302	R	G	B	R	G	B	R	G	B	R	G	B	-----	G	B	R	G	B	
303	R	G	B	R	G	B	R	G	B	R	G	B	-----	G	B	R	G	B	
304	R	G	B	R	G	B	R	G	B	R	G	B	-----	G	B	R	G	B	
305	R	G	B	R	G	B	R	G	B	R	G	B	-----	G	B	R	G	B	
⋮	⋮	⋮	⋮	⋮	⋮	⋮	⋮	⋮	⋮	⋮	⋮	⋮		⋮	⋮	⋮	⋮	⋮	
598	R	G	B	R	G	B	R	G	B	R	G	B	-----	G	B	R	G	B	
599	R	G	B	R	G	B	R	G	B	R	G	B	-----	G	B	R	G	B	
600	R	G	B	R	G	B	R	G	B	R	G	B	-----	G	B	R	G	B	
X	2	2	2	2	2	2	2	2	2	2	2	2		4	4	4	4	4	
	4	4	4	4	4	4	4	4	4	4	4	4		7	7	7	7	8	
	0	0	0	0	0	0	0	0	0	0	1	1	1	-----	9	9	9	9	0
Y	1	2	3	4	5	6	7	8	9	0	1	2		6	7	8	9	0	
Data Signal	L D 7	L D 6	L D 5	L D 4	L D 3	L D 2	L D 1	L D 0	L D 7	L D 6	L D 5	L D 4	-----	L D 4	L D 3	L D 2	L D 1	L D 0	

R : RED  
G : GREEN  
B : BLUE



## 8.6 INTERNAL PIN CONNECTION

CN1 Molex : SD-52974-040\* (Suitable Connector : Molex SD-53729-040\*)

PIN No.	SIGNAL	LEVEL	FUNCTION
1	GND	-	GND
2	CL2	H→L	Data Shift
3	GND	-	GND
4	GND	-	GND
5	CL1	H→L	Data Latch
6	FLM	H	First Line Marker
7	GND	-	GND
8	GND	-	GND
9	VDD	-	Power Supply for LCD
10	$\overline{\text{DISP}} \bullet \text{OFF}$	H/L	H : ON / L : OFF
11	GND	-	GND
12	GND	-	GND
13	GND	-	GND
14	LD7	H/L	Display Data (Lower Column)
15	LD6		
16	LD5		
17	LD4		
18	LD3		
19	LD2		
20	LD1		
21	LD0		
22	GND	-	GND
23	GND	-	GND
24	GND	-	GND
25	UD0	H/L	Display Data (Upper Column)
26	UD1		
27	UD2		
28	UD3		
29	UD4		
30	UD5		
31	UD6		
32	UD7		
33	GND	-	GND
34	GND	-	GND
35	GND	-	GND
36	VDD	-	Power Supply for LCD
37	VDD	-	Power Supply for LCD
38	VCON	-	Contrast Adjust
39	N.C	-	
40	GND	-	GND

CN2 JST : BHSR-02VS-1 (Suitable Connector : JST SM02B-BHSS-1)

PIN No.	SIGNAL	LEVEL	FUNCTION
1	VCFL	A C	Power Supply for CFL
2	VSS	-	GND for CFL

CN3 JST : BHSR-02VS-1 (Suitable Connector : JST SM02B-BHSS-1)

PIN No.	SIGNAL	LEVEL	FUNCTION
1	VCFL	A C	Power Supply for CFL
2	VSS	-	GND for CFL

## 10. PRECAUTION IN DESIGN

### 10.1 MOUNTING PRECAUTION

Please mount the LCD Module using mounting holes arranged in 4 corners, and please pay attention to the follow ings.

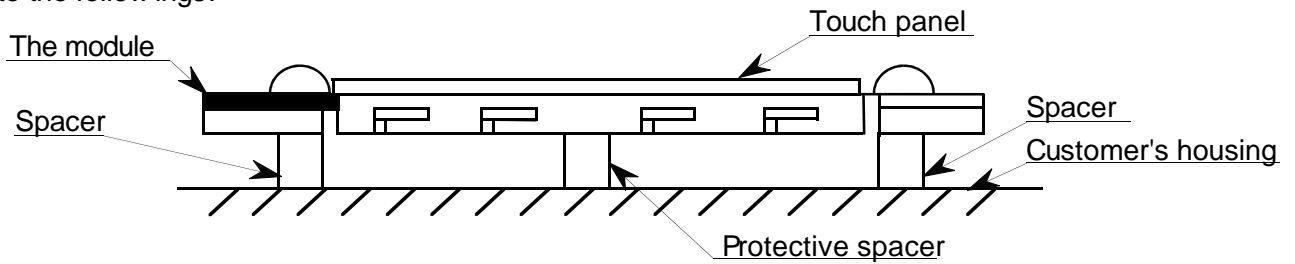

Example of mounting

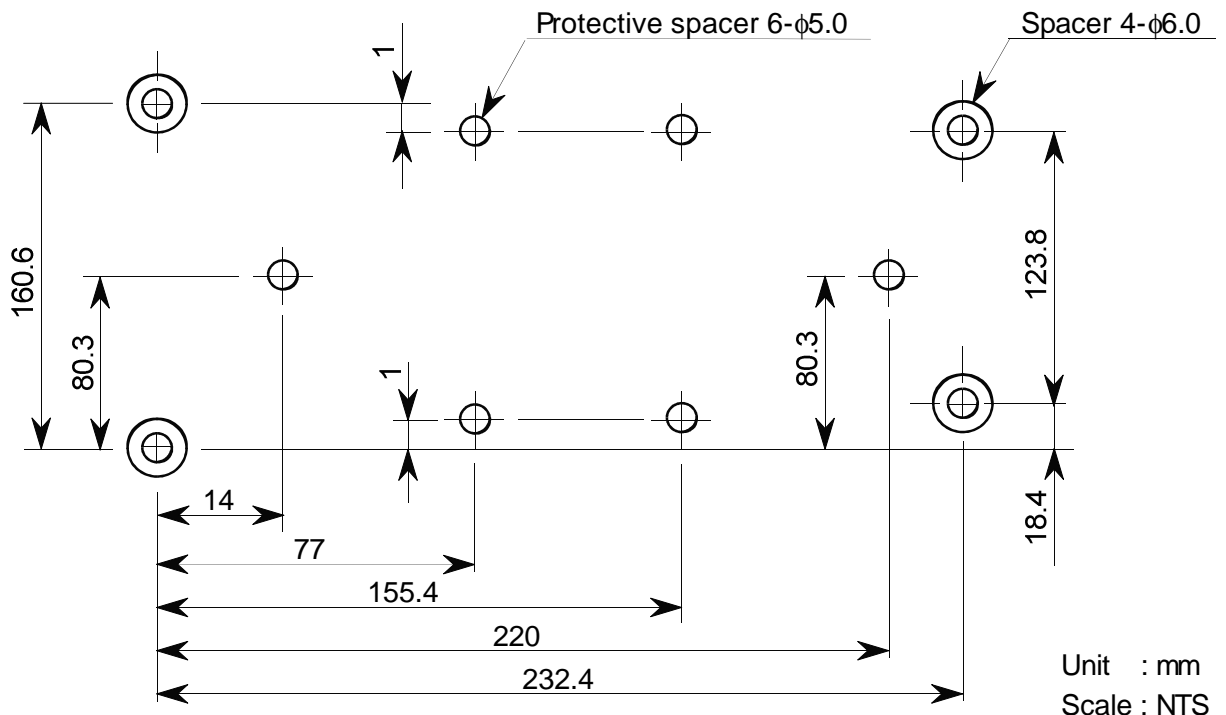

Location of spacers

- (1) To prevent the module cover from being pressed, the distance between the module and the fitting plate, which means the length of the spacers, should be shorter than 1.0mm.
- (2) We recommend you to use protective spacers in order to protect the module from any kinds of shocks to your set.
- (3) There are some parts (CFL, LSI, etc) on edge of our module. Please be careful with handling when you assemble (without any stress).
- (4) When you insert the connector to our module, please be careful with inserting it without slant.

- (5) We recommend you to use the spacer or the Adhesive Tape in order to prevent coming off the suitable connector.

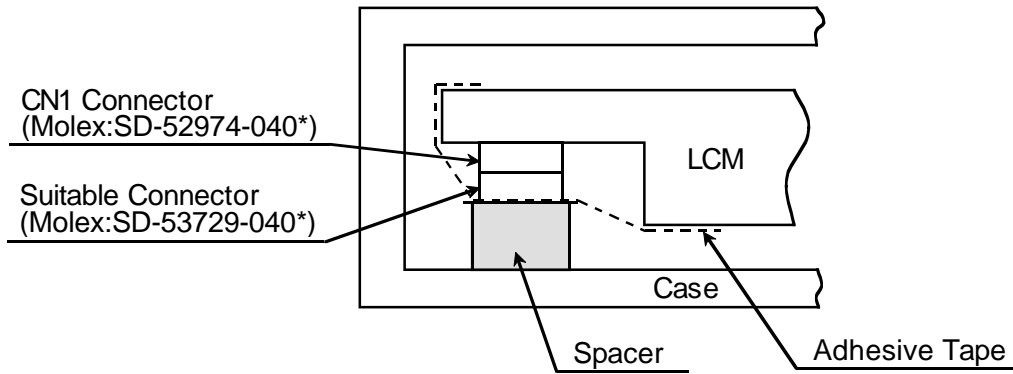

- (6) For the module to be used at upright position, the case shall have a structure where the touch panel screen does not shift with its own weight.
- (7) When assembling the touch panel and your case, please refer to the figure below.

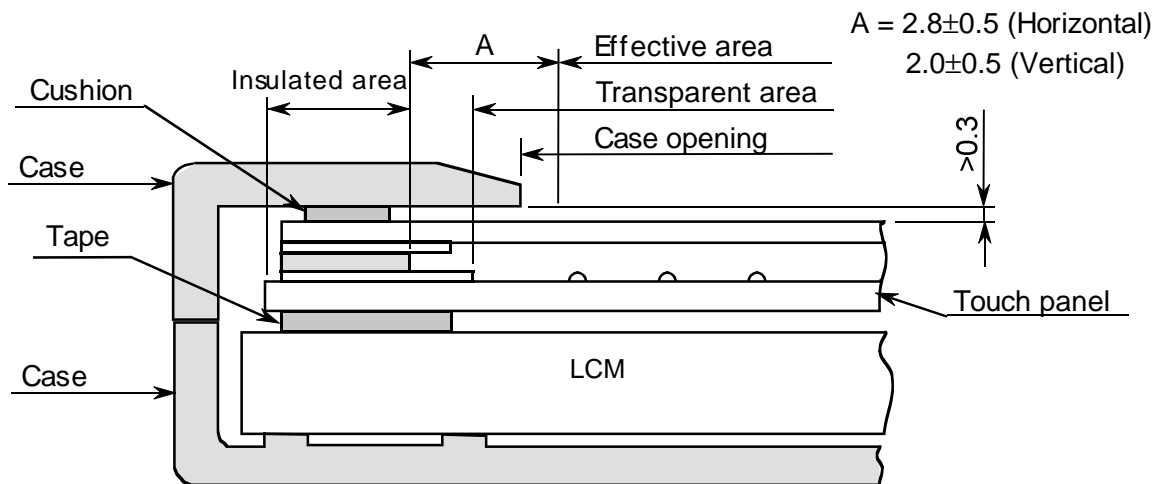

- (8) The clearance between the touch panel and the case shall be designed so that the case edge never presses the input screen when it is deformed by heat or other causes.
- (9) The case shall be designed not to touch the tail portion (FPC for touch panel).
- (10) The boundary space between the effective area and the insulated area is unstable. Touching this area may effect the operation of the touch panel. The case must be designed so that it does not touch the boundary space.