

SR CONNECTOR

Disconnectable insulation displacement connectors

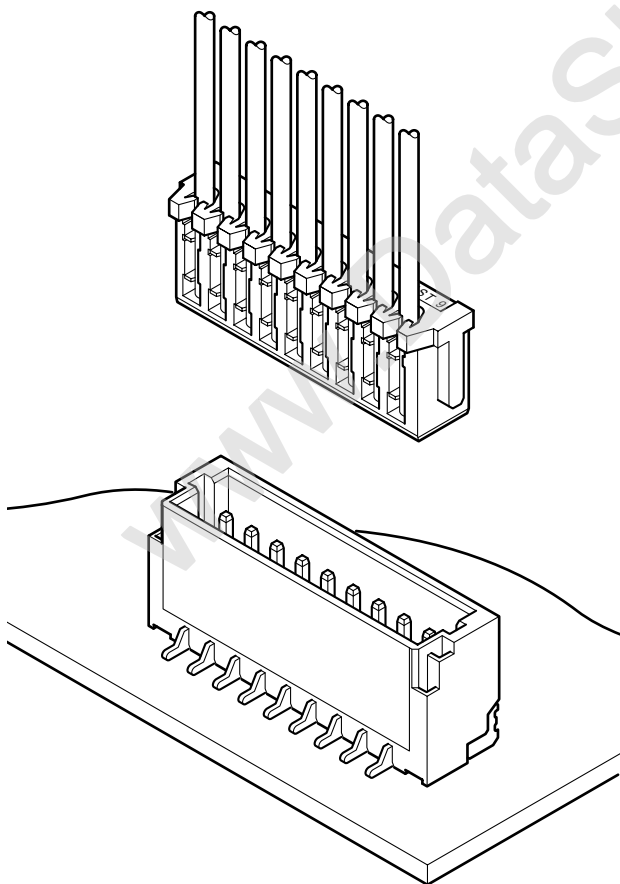
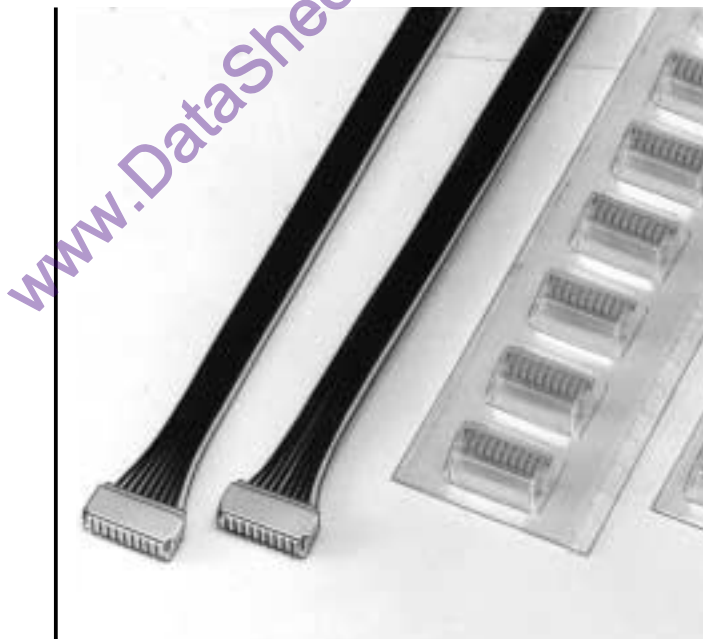

Features

• Ultra-compact insulation displacement connector

1.0mm (.039") pitch and only 3.0mm (.118") high (side entry type). This connector is only about 61% as large as the smallest conventional (JST) IDC designs.

• Header designed for vacuum pick and place robotics

Although this shrouded header has locking features for its mating receptacle, there are no holes in the header shroud that would adversely effect vacuum gripping equipment. Since there is enough flat surface for secure vacuum gripping, this miniature surface mount connector is versatile for designers and economic for manufacturing.

• Twin U-slot insulation displacement section

The insulation displacement section connected to each wire consists of two tin-plated slots (twin U-slots), which ensures reliable connection.

• 3-point grip construction

The 3-point insulation grip feature and the strain relief ensure a firm grip on terminated wires and protection of the insulation displacement connection from possible damage.

Specifications

- Current rating: 0.7A DC
- Voltage rating: 50V DC
- Temperature range: -25°C to +85°C (including temperature rise in applying electrical current)
- Contact resistance: Initial value/20m Ω max.
After environmental testing/40m Ω max.
- Insulation resistance: 100M Ω min.
- Withstanding voltage: 500V AC/minute
- Applicable wire: AWG #30
Conductor/7 strands,
tin-coated annealed copper
Insulation O.D./0.56mm (.022")

* Contact JST for details.

Standards

- Recognized E60389
- ↑ Certified LR20812

SR CONNECTOR

Receptacle

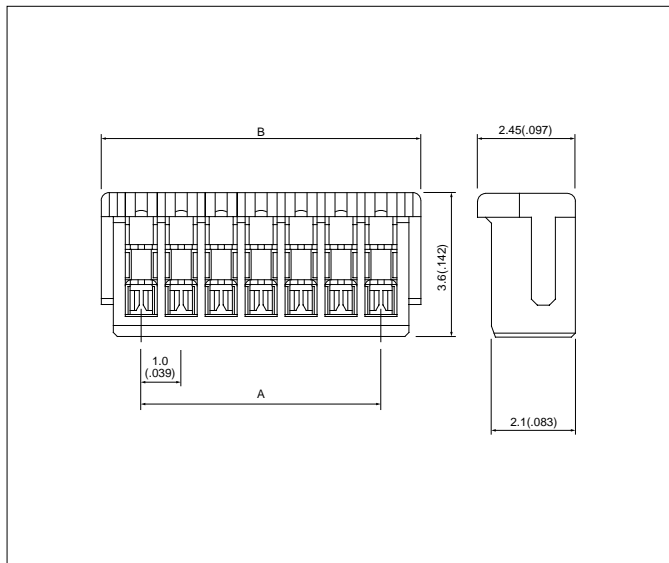

Circuits	Model No.	Dimensions mm(in.)		Q'ty / box
		A	B	
2	02SR-3S	1.0(.039)	3.0(.118)	3,000
3	03SR-3S	2.0(.079)	4.0(.157)	3,000
4	04SR-3S	3.0(.118)	5.0(.197)	3,000
5	05SR-3S	4.0(.157)	6.0(.236)	2,000
6	06SR-3S	5.0(.197)	7.0(.276)	2,000
7	07SR-3S	6.0(.236)	8.0(.315)	2,000
8	08SR-3S	7.0(.276)	9.0(.354)	2,000
9	09SR-3S	8.0(.315)	10.0(.394)	2,000
10	10SR-3S	9.0(.354)	11.0(.433)	2,000
11	11SR-3S	10.0(.394)	12.0(.472)	2,000
12	12SR-3S	11.0(.433)	13.0(.512)	2,000
13	13SR-3S	12.0(.472)	14.0(.551)	2,000
14	14SR-3S	13.0(.512)	15.0(.591)	2,000

Material and Finish

Contact: Phosphor bronze, tin-plated
Housing: Polyamide 66, UL94V-0, natural (ivory)

Shrouded header

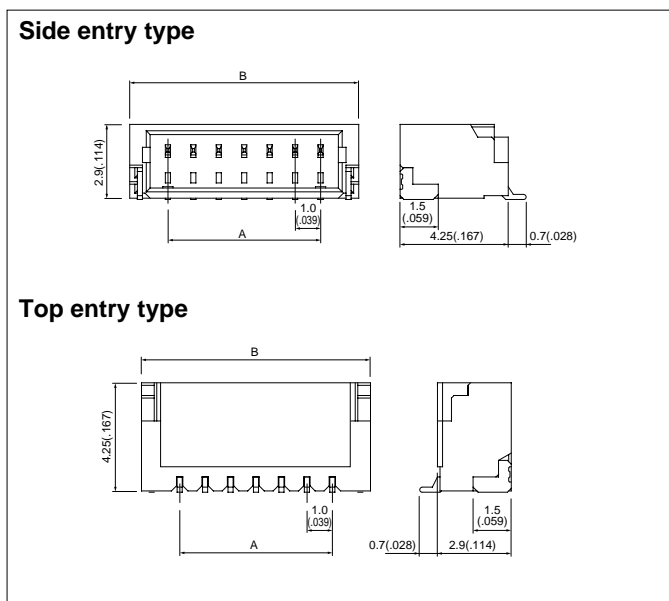

Circuits	Top entry type	Side entry type	Dimensions mm(in.)		Q'ty / reel	
			A	B	Top entry type	Side entry type
2	BM02B-SRSS-TB	SM02B-SRSS-TB	1.0(.039)	4.0(.157)	1,500	3,000
3	BM03B-SRSS-TB	SM03B-SRSS-TB	2.0(.079)	5.0(.197)	1,500	3,000
4	BM04B-SRSS-TB	SM04B-SRSS-TB	3.0(.118)	6.0(.236)	1,500	3,000
5	BM05B-SRSS-TB	SM05B-SRSS-TB	4.0(.157)	7.0(.276)	1,500	3,000
6	BM06B-SRSS-TB	SM06B-SRSS-TB	5.0(.197)	8.0(.315)	1,500	3,000
7	BM07B-SRSS-TB	SM07B-SRSS-TB	6.0(.236)	9.0(.354)	1,500	3,000
8	BM08B-SRSS-TB	SM08B-SRSS-TB	7.0(.276)	10.0(.394)	1,500	3,000
9	BM09B-SRSS-TB	SM09B-SRSS-TB	8.0(.315)	11.0(.433)	1,500	3,000
10	BM10B-SRSS-TB	SM10B-SRSS-TB	9.0(.354)	12.0(.472)	1,500	3,000
11	BM11B-SRSS-TB	SM11B-SRSS-TB	10.0(.394)	13.0(.512)	1,500	3,000
12	BM12B-SRSS-TB	SM12B-SRSS-TB	11.0(.433)	14.0(.551)	1,500	3,000
13	BM13B-SRSS-TB	SM13B-SRSS-TB	12.0(.472)	15.0(.591)	1,500	3,000
14	BM14B-SRSS-TB	SM14B-SRSS-TB	13.0(.512)	16.0(.630)	1,500	3,000

Material and Finish

Contact: Copper alloy, copper-undercoated, tin/lead plated
Wafer: Polyamide, UL94V-0, natural (ivory)
Solder tab: Brass, copper-undercoated, tin/lead plated

- Note: 1. The products listed above are supplied on embossed-tape.
2. Contact JST for the top entry type headers with suction cap.

PC board layout (viewed from component side) and Assembly layout

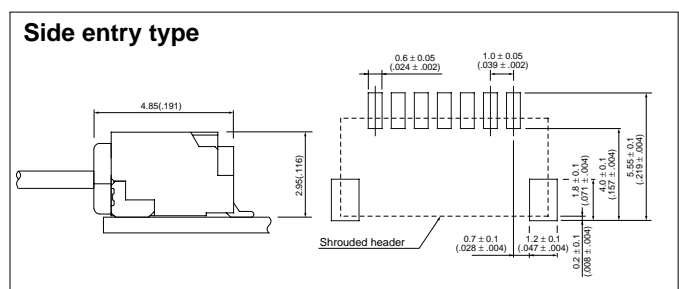
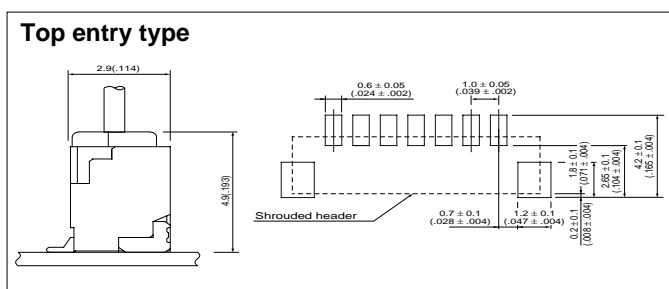

- Note: 1. Tolerances are non-cumulative: $\pm 0.05\text{mm} (\pm .002")$ for all centers.
2. Dimensions above should serve as a guideline. Contact JST for details.

Taping specifications

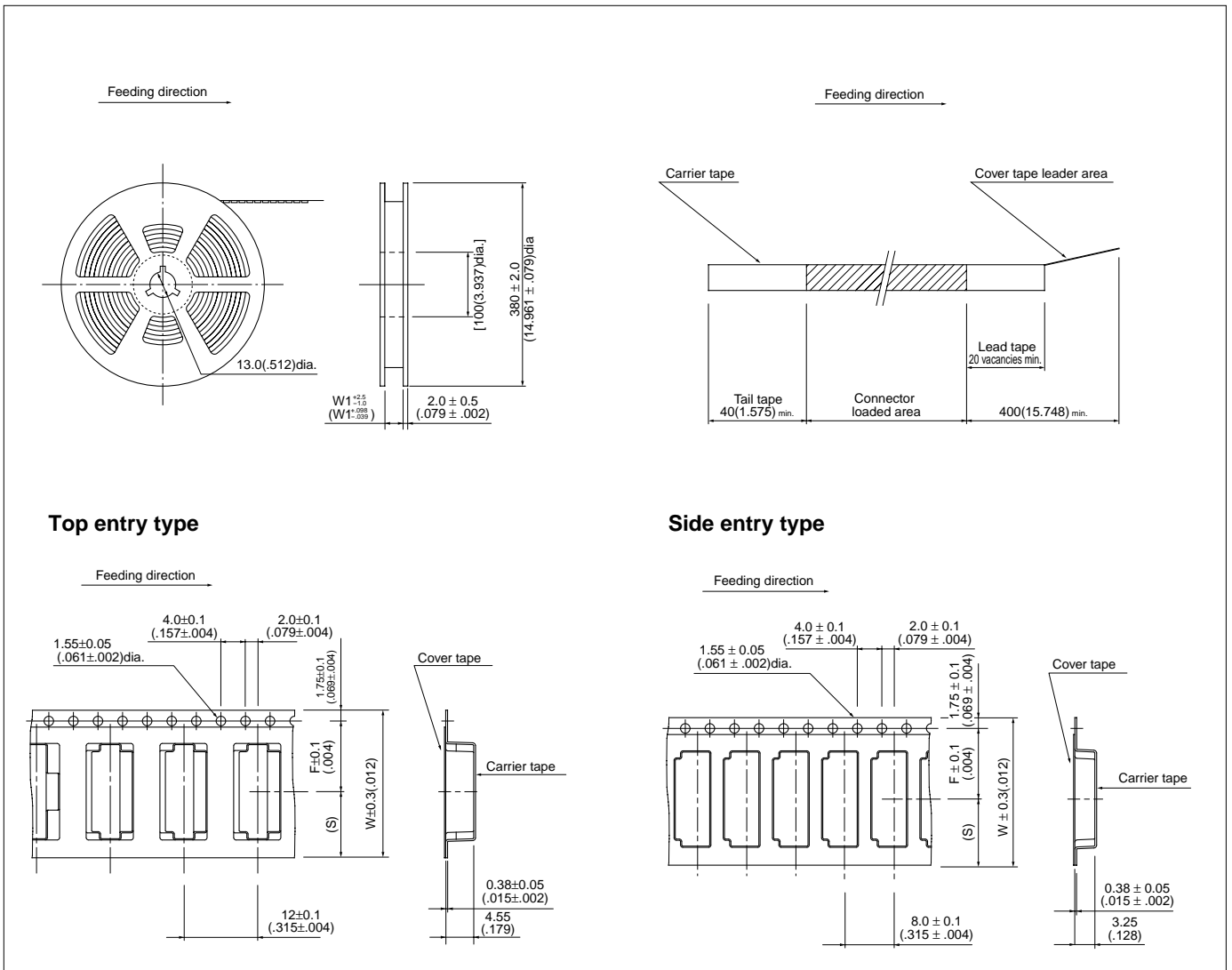

Circuits	Taping dimensions mm(in.)						Reel dimensions mm(in.)		Q'ty / reel	
	F		S		W		W1		Top entry type	Side entry type
	Top entry type	Side entry type	Top entry type	Side entry type	Top entry type	Side entry type	Top entry type	Side entry type		
2 to 3	5.5(.217)	5.5(.217)	4.75(.187)	4.75(.187)	12(.472)	12(.472)	13.5(.531)	13.5(.531)	1,500	3,000
4	7.5(.295)	5.5(.217)	6.75(.266)	4.75(.187)	16(.630)	12(.472)	17.5(.689)	13.5(.531)	1,500	3,000
5 to 7	7.5(.295)	7.5(.295)	6.75(.266)	6.75(.266)	16(.630)	16(.630)	17.5(.689)	17.5(.689)	1,500	3,000
8	11.5(.453)	7.5(.295)	10.75(.423)	6.75(.266)	24(.945)	16(.630)	25.5(1.004)	17.5(.689)	1,500	3,000
9 to 14	11.5(.453)	11.5(.453)	10.75(.423)	10.75(.423)	24(.945)	24(.945)	25.5(1.004)	25.5(1.004)	1,500	3,000

Note:

- Specifications conform to JIS C 0806. The tape width, connector recess hole dimensions, etc. are determined by the number of circuits and external shape of the connector to be loaded.
- Specifications are subject to change without prior notice.