

# Am29DLI6xD

Data Sheet



July 2003

The following document specifies Spansion memory products that are now offered by both Advanced Micro Devices and Fujitsu. Although the document is marked with the name of the company that originally developed the specification, these products will be offered to customers of both AMD and Fujitsu.

## Continuity of Specifications

There is no change to this datasheet as a result of offering the device as a Spansion product. Any changes that have been made are the result of normal datasheet improvement and are noted in the document revision summary, where supported. Future routine revisions will occur when appropriate, and changes will be noted in a revision summary.

## Continuity of Ordering Part Numbers

AMD and Fujitsu continue to support existing part numbers beginning with "Am" and "MBM". To order these products, please use only the Ordering Part Numbers listed in this document.

## For More Information

Please contact your local AMD or Fujitsu sales office for additional information about Spansion memory solutions.

Publication Number 21533 Revision E Amendment +3 Issue Date February 25, 2004



**THIS PAGE LEFT INTENTIONALLY BLANK.**



# Am29DL16xD

16 Megabit (2 M x 8-Bit/1 M x 16-Bit)

CMOS 3.0 Volt-only, Simultaneous Operation Flash Memory

## DISTINCTIVE CHARACTERISTICS

### ARCHITECTURAL ADVANTAGES

#### ■ Simultaneous Read/Write operations

- Data can be continuously read from one bank while executing erase/program functions in other bank
- Zero latency between read and write operations

#### ■ Multiple bank architectures

- Four devices available with different bank sizes (refer to Table 2)

#### ■ SecSi™ (Secured Silicon) Sector

- Current version of device has 64 Kbytes; future versions will have 256 bytes
- *Factory locked and identifiable*: 16 bytes available for secure, random factory Electronic Serial Number; verifiable as factory locked through autoselect function. ExpressFlash option allows entire sector to be available for factory-secured data
- *Customer lockable*: Can be read, programmed, or erased just like other sectors. Once locked, data cannot be changed

#### ■ Zero Power Operation

- Sophisticated power management circuits reduce power consumed during inactive periods to nearly zero

#### ■ Package options

- 48-ball Very Thin Profile Fine-pitch BGA
- 48-ball Fine-pitch BGA
- 64-ball Fortified BGA
- 48-pin TSOP

#### ■ Top or bottom boot block

#### ■ Manufactured on 0.23 µm process technology

- Compatible with Am29DL16xC devices

#### ■ Compatible with JEDEC standards

- Pinout and software compatible with single-power-supply flash standard

### PERFORMANCE CHARACTERISTICS

#### ■ High performance

- Access time as fast 70 ns
- Program time: 7 µs/word typical utilizing Accelerate function

#### ■ Ultra low power consumption (typical values)

- 2 mA active read current at 1 MHz

- 10 mA active read current at 5 MHz
- 200 nA in standby or automatic sleep mode

#### ■ Minimum 1 million write cycles guaranteed per sector

#### ■ 20 Year data retention at 125°C

- Reliable operation for the life of the system

### SOFTWARE FEATURES

#### ■ Data Management Software (DMS)

- AMD-supplied software manages data programming and erasing, enabling EEPROM emulation
- Eases sector erase limitations

#### ■ Supports Common Flash Memory Interface (CFI)

#### ■ Erase Suspend/Erase Resume

- Suspends erase operations to allow programming in same bank

#### ■ Data# Polling and Toggle Bits

- Provides a software method of detecting the status of program or erase cycles

#### ■ Unlock Bypass Program command

- Reduces overall programming time when issuing multiple program command sequences

### HARDWARE FEATURES

#### ■ Any combination of sectors can be erased

#### ■ Ready/Busy# output (RY/BY#)

- Hardware method for detecting program or erase cycle completion

#### ■ Hardware reset pin (RESET#)

- Hardware method of resetting the internal state machine to reading array data

#### ■ WP#/ACC input pin

- Write protect (WP#) function allows protection of two outermost boot sectors, regardless of sector protect status
- Acceleration (ACC) function accelerates program timing

#### ■ Sector protection

- Hardware method of locking a sector, either in-system or using programming equipment, to prevent any program or erase operation within that sector
- Temporary Sector Unprotect allows changing data in protected sectors in-system

## GENERAL DESCRIPTION

The Am29DL16xD family consists of 16 megabit, 3.0 volt-only flash memory devices, organized as 1,048,576 words of 16 bits each or 2,097,152 bytes of 8 bits each. Word mode data appears on DQ0–DQ15; byte mode data appears on DQ0–DQ7. The device is designed to be programmed in-system with the standard 3.0 volt  $V_{CC}$  supply, and can also be programmed in standard EPROM programmers.

The device is available with an access time of 70, 90, or 120 ns. The devices are offered in 48-pin TSOP, 48-ball Fine-pitch BGA, 48-ball Very Thin Profile Fine-pitch BGA, and 64-ball Fortified BGA packages. Standard control pins—chip enable (CE#), write enable (WE#), and output enable (OE#)—control normal read and write operations, and avoid bus contention issues.

The device requires only a **single 3.0 volt power supply** for both read and write functions. Internally generated and regulated voltages are provided for the program and erase operations.

### Simultaneous Read/Write Operations with Zero Latency

The Simultaneous Read/Write architecture provides **simultaneous operation** by dividing the memory space into two banks. The device can improve overall system performance by allowing a host system to program or erase in one bank, then immediately and simultaneously read from the other bank, with zero latency. This releases the system from waiting for the completion of program or erase operations.

The Am29DL16xD devices uses multiple bank architectures to provide flexibility for different applications. Four devices are available with these bank sizes:

Device	Bank 1	Bank 2
DL161	0.5 Mb	15.5 Mb
DL162	2 Mb	14 Mb
DL163	4 Mb	12 Mb
DL164	8 Mb	8 Mb

### Am29DL16xD Features

The **SecSi™** (Secured Silicon) Sector is an extra sector capable of being permanently locked by AMD or customers. The **SecSi Sector Indicator Bit** (DQ7) is permanently set to a 1 if the part is **factory locked**, and set to a 0 if **customer lockable**. This way, customer lockable parts can never be used to replace a factory locked part. **Current version of device has 64 Kbytes; future versions will have only 256 bytes. This should be considered during system design.**

Factory locked parts provide several options. The SecSi Sector may store a secure, random 16 byte ESN (Electronic Serial Number), customer code (programmed through AMD's ExpressFlash service), or

both. Customer Lockable parts may utilize the SecSi Sector as bonus space, reading and writing like any other flash sector, or may permanently lock their own code there.

**DMS (Data Management Software)** allows systems to easily take advantage of the advanced architecture of the simultaneous read/write product line by allowing removal of EEPROM devices. DMS will also allow the system software to be simplified, as it will perform all functions necessary to modify data in file structures, as opposed to single-byte modifications. To write or update a particular piece of data (a phone number or configuration data, for example), the user only needs to state which piece of data is to be updated, and where the updated data is located in the system. This is an advantage compared to systems where user-written software must keep track of the old data location, status, logical to physical translation of the data onto the Flash memory device (or memory devices), and more. Using DMS, user-written software does not need to interface with the Flash memory directly. Instead, the user's software accesses the Flash memory by calling one of only six functions. AMD provides this software to simplify system design and software integration efforts.

The device offers complete compatibility with the **JEDEC single-power-supply Flash command set standard**. Commands are written to the command register using standard microprocessor write timings. Reading data out of the device is similar to reading from other Flash or EPROM devices.

The host system can detect whether a program or erase operation is complete by using the device **status bits**: RY/BY# pin, DQ7 (Data# Polling) and DQ6/DQ2 (toggle bits). After a program or erase cycle has been completed, the device automatically returns to reading array data.

The **sector erase architecture** allows memory sectors to be erased and reprogrammed without affecting the data contents of other sectors. The device is fully erased when shipped from the factory.

**Hardware data protection** measures include a low  $V_{CC}$  detector that automatically inhibits write operations during power transitions. The **hardware sector protection** feature disables both program and erase operations in any combination of the sectors of memory. This can be achieved in-system or via programming equipment.

The device offers two power-saving features. When addresses have been stable for a specified amount of time, the device enters the **automatic sleep mode**. The system can also place the device into the **standby mode**. Power consumption is greatly reduced in both modes.

## TABLE OF CONTENTS

<b>Product Selector Guide</b> .....	<b>5</b>	Sector Erase Command Sequence .....	26
<b>Block Diagram</b> .....	<b>5</b>	Erase Suspend/Erase Resume Commands .....	27
<b>Connection Diagrams</b> .....	<b>6</b>	Figure 4. Erase Operation .....	27
Special Package Handling Instructions .....	8	Command Definitions .....	28
<b>Pin Description</b> .....	<b>9</b>	Table 14. Am29DL16xD Command Definitions .....	28
<b>Logic Symbol</b> .....	<b>9</b>	<b>Write Operation Status</b> .....	<b>29</b>
<b>Ordering Information</b> .....	<b>10</b>	DQ7: Data# Polling .....	29
<b>Device Bus Operations</b> .....	<b>11</b>	Figure 5. Data# Polling Algorithm .....	29
Table 1. Am29DL16xD Device Bus Operations .....	11	RY/BY#: Ready/Busy# .....	30
Word/Byte Configuration .....	11	DQ6: Toggle Bit I .....	30
Requirements for Reading Array Data .....	11	Figure 6. Toggle Bit Algorithm .....	30
Writing Commands/Command Sequences .....	12	DQ2: Toggle Bit II .....	31
Accelerated Program Operation .....	12	Reading Toggle Bits DQ6/DQ2 .....	31
Autoselect Functions .....	12	DQ5: Exceeded Timing Limits .....	31
Simultaneous Read/Write Operations with Zero Latency .....	12	DQ3: Sector Erase Timer .....	31
Standby Mode .....	12	Table 15. Write Operation Status .....	32
Automatic Sleep Mode .....	12	<b>Absolute Maximum Ratings</b> .....	<b>33</b>
RESET#: Hardware Reset Pin .....	13	Figure 7. Maximum Negative Overshoot Waveform .....	33
Output Disable Mode .....	13	Figure 8. Maximum Positive Overshoot Waveform .....	33
Table 2. Am29DL16xD Device Bank Divisions .....	13	<b>Operating Ranges</b> .....	<b>33</b>
Table 3. Sector Addresses for Top Boot Sector Devices .....	14	<b>DC Characteristics</b> .....	<b>34</b>
Table 4. SecSi™ Sector Addresses for Top Boot Devices .....	14	Figure 9. I <sub>CC1</sub> Current vs. Time (Showing Active and Automatic Sleep Currents).....	35
Table 5. Sector Addresses for Bottom Boot Sector Devices .....	15	Figure 10. Typical I <sub>CC1</sub> vs. Frequency.....	35
Table 6. SecSi™ Addresses for Bottom Boot Devices .....	15	<b>Test Conditions</b> .....	<b>36</b>
Autoselect Mode .....	16	Figure 11. Test Setup .....	36
Table 7. Am29DL16xD Autoselect Codes, (High Voltage Method) .....	16	Table 16. Test Specifications .....	36
Sector/Sector Block Protection and Unprotection .....	17	Key To Switching Waveforms .....	36
Table 8. Top Boot Sector/Sector Block Addresses for Protection/Unprotection .....	17	Figure 12. Input Waveforms and Measurement Levels.....	36
Table 9. Bottom Boot Sector/Sector Block Addresses for Protection/Unprotection .....	17	<b>AC Characteristics</b> .....	<b>37</b>
Write Protect (WP#) .....	18	Figure 13. Read Operation Timings.....	37
Temporary Sector/Sector Block Unprotect .....	18	Figure 14. Reset Timings.....	38
Figure 1. Temporary Sector Unprotect Operation.....	18	Word/Byte Configuration (BYTE#) .....	39
Figure 2. In-System Sector/Sector Block Protection and Unprotection Algorithms.....	19	Figure 15. BYTE# Timings for Read Operations .....	39
SecSi™ (Secured Silicon) Sector Flash Memory Region .....	20	Figure 16. BYTE# Timings for Write Operations .....	39
Factory Locked: SecSi Sector Programmed and Protected At the Factory .....	20	Erase and Program Operations .....	40
Customer Lockable: SecSi Sector NOT Programmed or Protected At the Factory .....	20	Figure 17. Program Operation Timings .....	41
Hardware Data Protection .....	20	Figure 18. Accelerated Program Timing Diagram .....	41
Low VCC Write Inhibit .....	21	Figure 19. Chip/Sector Erase Operation Timings .....	42
Write Pulse “Glitch” Protection .....	21	Figure 20. Back-to-back Read/Write Cycle Timings .....	43
Logical Inhibit .....	21	Figure 21. Data# Polling Timings (During Embedded Algorithms) .....	43
Power-Up Write Inhibit .....	21	Figure 22. Toggle Bit Timings (During Embedded Algorithms) .....	44
Figure 3. Program Operation .....	26	Figure 23. DQ2 vs. DQ6 .....	44
Chip Erase Command Sequence .....	26	Temporary Sector/Sector Block Unprotect .....	45
<b>Common Flash Memory Interface (CFI)</b> .....	<b>21</b>	Figure 24. Temporary Sector/Sector Block Unprotect Timing Diagram .....	45
Table 10. CFI Query Identification String.....	21	Figure 25. Sector/Sector Block Protect and Unprotect Timing Diagram .....	46
Table 11. System Interface String.....	22	Alternate CE# Controlled Erase and Program Operations .....	47
Table 12. Device Geometry Definition .....	22	Figure 26. Alternate CE# Controlled Write (Erase/Program) Operation Timings .....	48
Table 13. Primary Vendor-Specific Extended Query .....	23	<b>Erase And Programming Performance</b> .....	<b>49</b>
<b>Command Definitions</b> .....	<b>24</b>	<b>Latchup Characteristics</b> .....	<b>49</b>
Reading Array Data .....	24	<b>Package and Pin Capacitance</b> .....	<b>49</b>
Reset Command .....	24	<b>Data Retention</b> .....	<b>49</b>
Autoselect Command Sequence .....	24	FBC048—48-Ball Fine-Pitch Ball Grid Array 8 x 9 mm package .....	50
Enter SecSi™ Sector/Exit SecSi Sector Command Sequence .....	25	LAA064—64-Ball Fortified Ball Grid Array, 13 x 11 mm package .....	51
Byte/Word Program Command Sequence .....	25	TS 048—48-Pin Standard TSOP .....	52
Unlock Bypass Command Sequence .....	25	VBF048—48-Ball Very Thin Profile Fine-Pitch Ball Grid Array .....	53
Figure 3. Program Operation .....	26	<b>Revision Summary</b> .....	<b>54</b>

## PRODUCT SELECTOR GUIDE

Part Number		Am29DL16xD		
Speed Option	Standard Voltage Range: $V_{CC} = 2.7\text{--}3.6\text{ V}$	70	90	120
Max Access Time (ns)		70	90	120
CE# Access (ns)		70	90	120
OE# Access (ns)		30	40	50

## BLOCK DIAGRAM

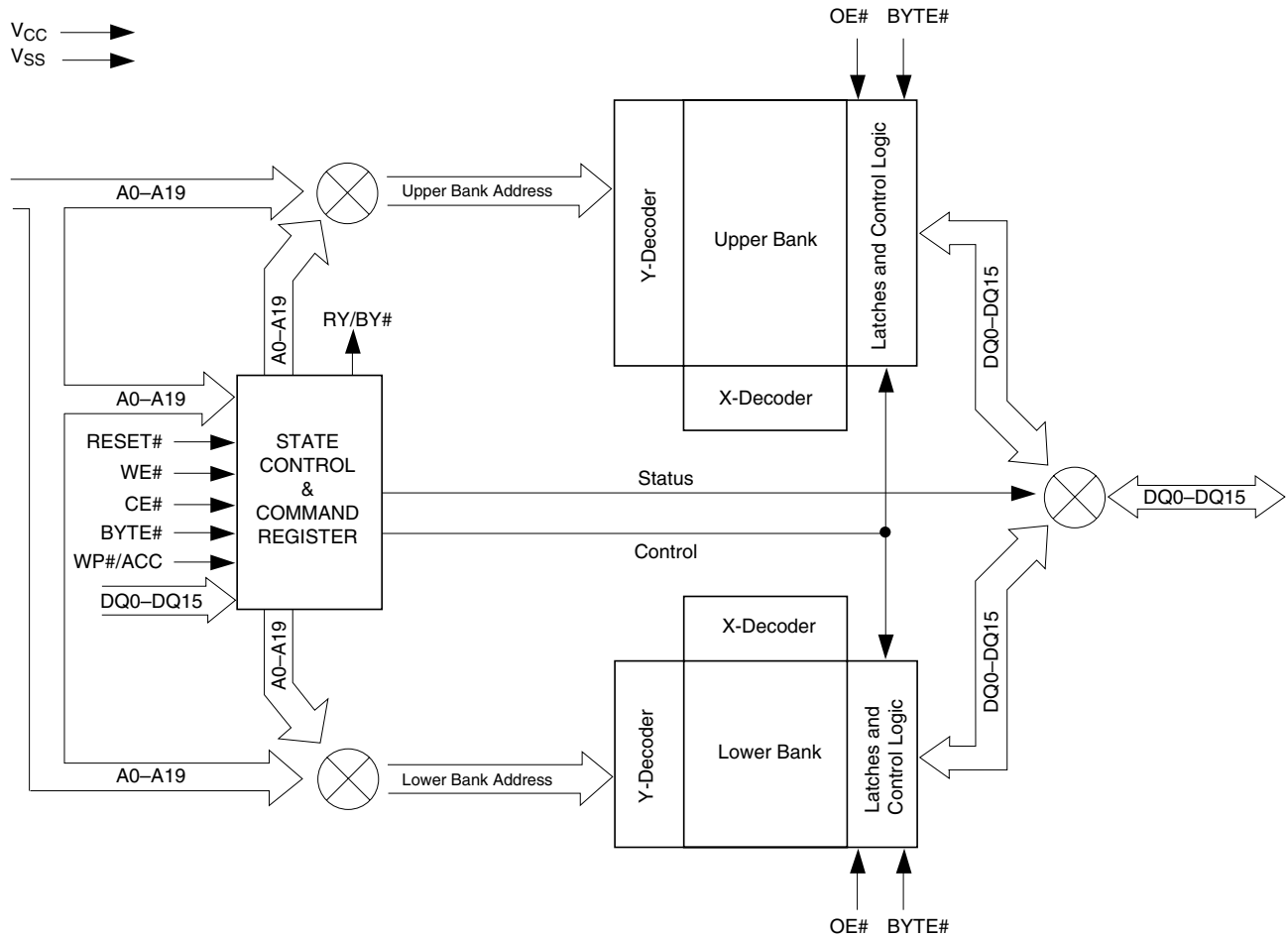

## CONNECTION DIAGRAMS

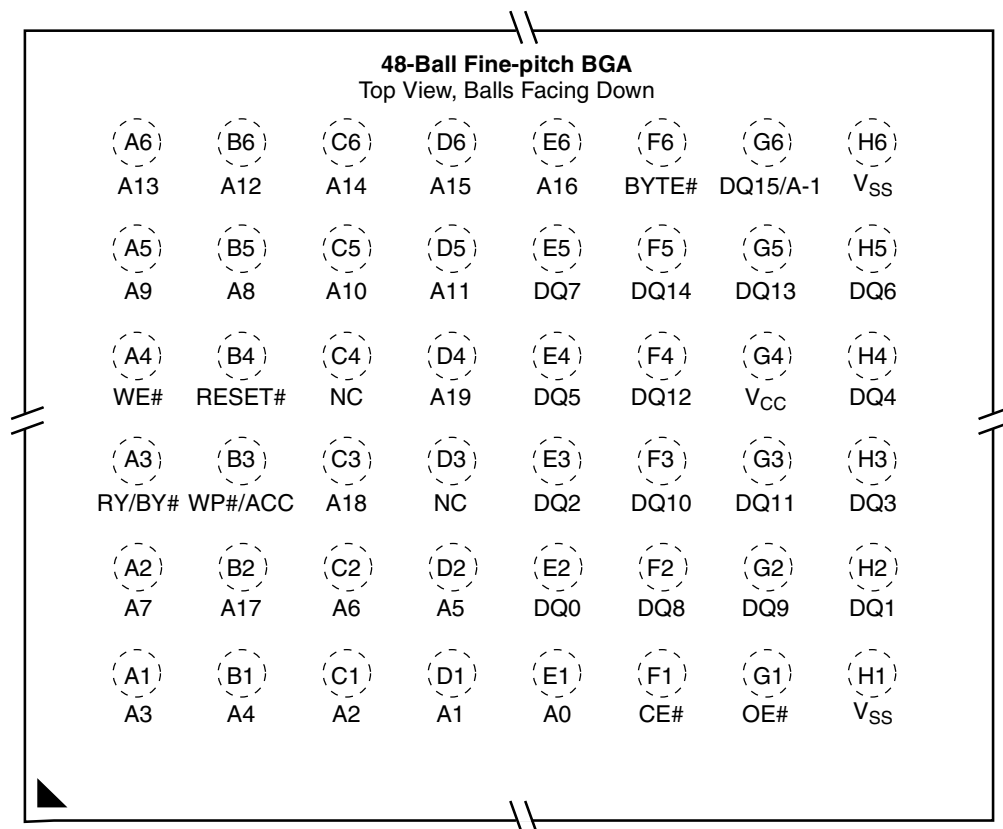
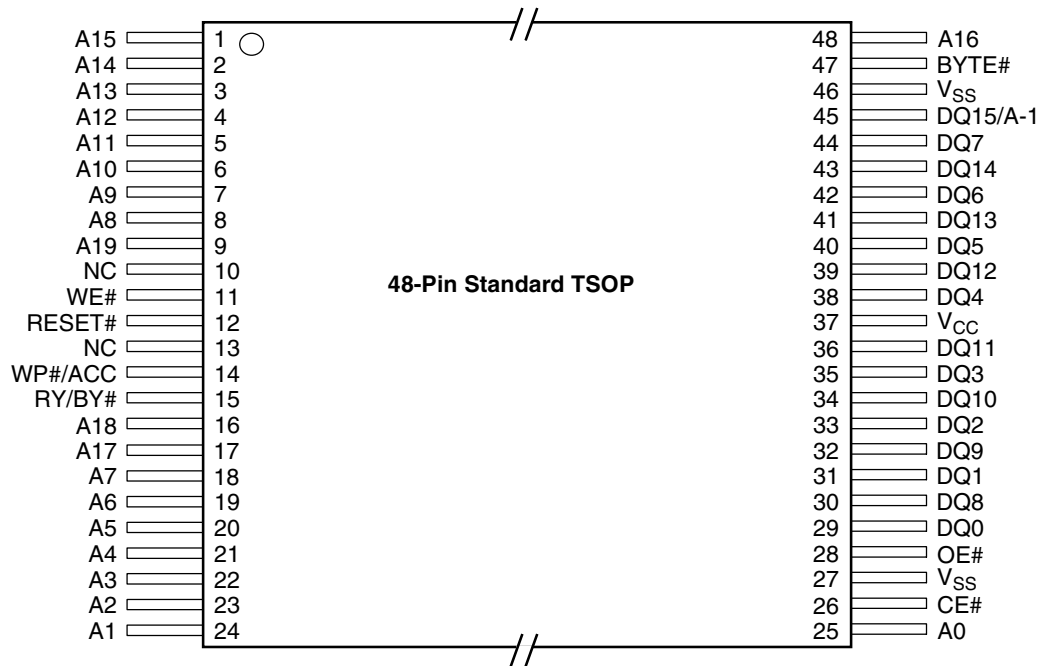

CONNECTION DIAGRAMS

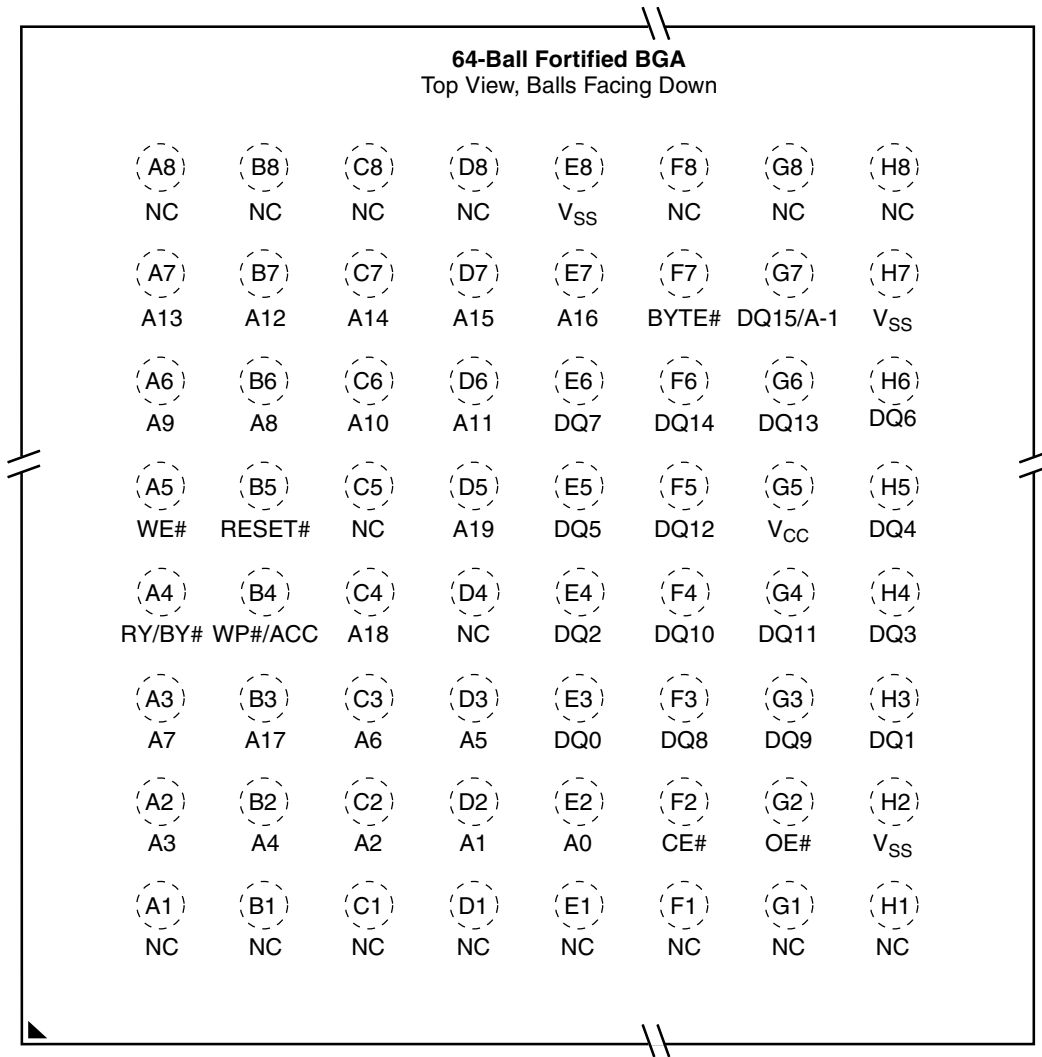



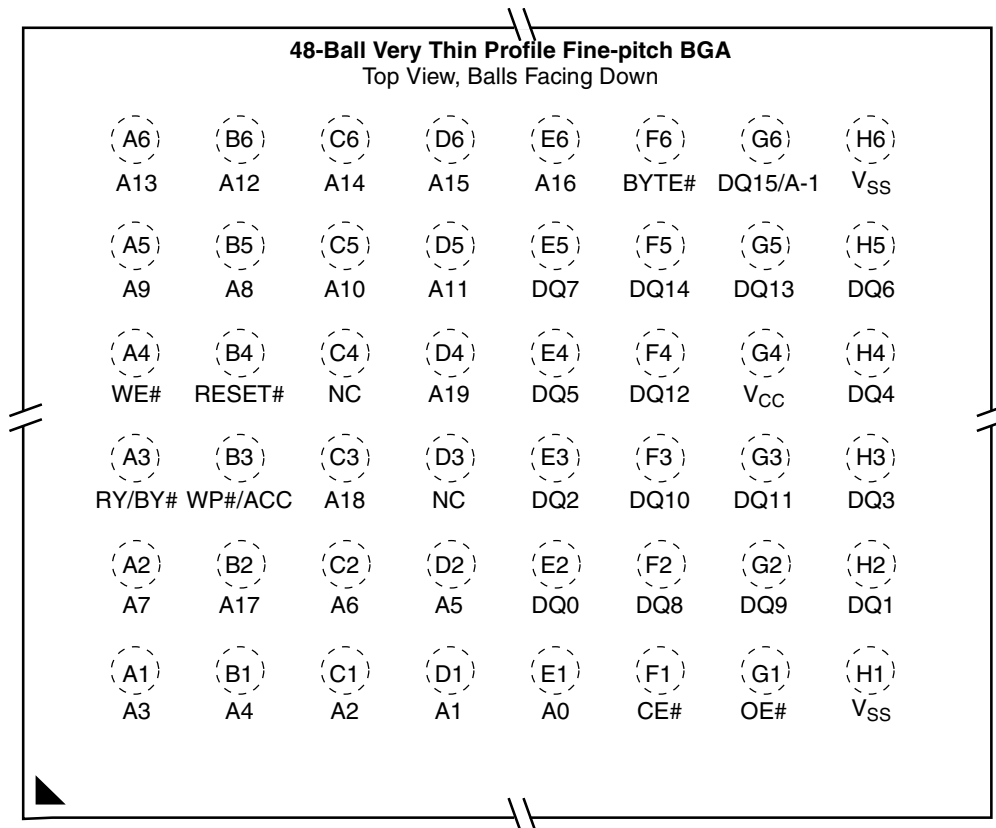

### Special Package Handling Instructions

Special handling is required for Flash Memory products in molded packages (BGA, TSOP, SO, PLCC, PDIP). The package and/or data integrity may be compromised if the package body is exposed to temperatures above 150°C for prolonged periods of time.

## PIN DESCRIPTION

A0–A19	= 20 Addresses
DQ0–DQ14	= 15 Data Inputs/Outputs
DQ15/A-1	= DQ15 (Data Input/Output, word mode), A-1 (LSB Address Input, byte mode)
CE#	= Chip Enable
OE#	= Output Enable
WE#	= Write Enable
WP#/ACC	= Hardware Write Protect/ Acceleration Pin
RESET#	= Hardware Reset Pin, Active Low
BYTE#	= Selects 8-bit or 16-bit mode
RY/BY#	= Ready/Busy Output
V <sub>CC</sub>	= 3.0 volt-only single power supply (see Product Selector Guide for speed options and voltage supply tolerances)
V <sub>SS</sub>	= Device Ground
NC	= Pin Not Connected Internally

## LOGIC SYMBOL

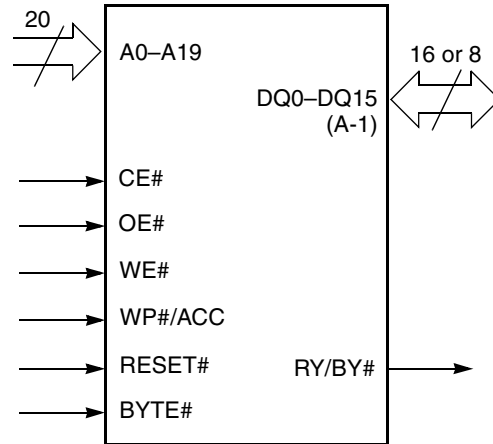

## ORDERING INFORMATION

### Standard Products

AMD standard products are available in several packages and operating ranges. The order number (Valid Combination) is formed by a combination of the following:

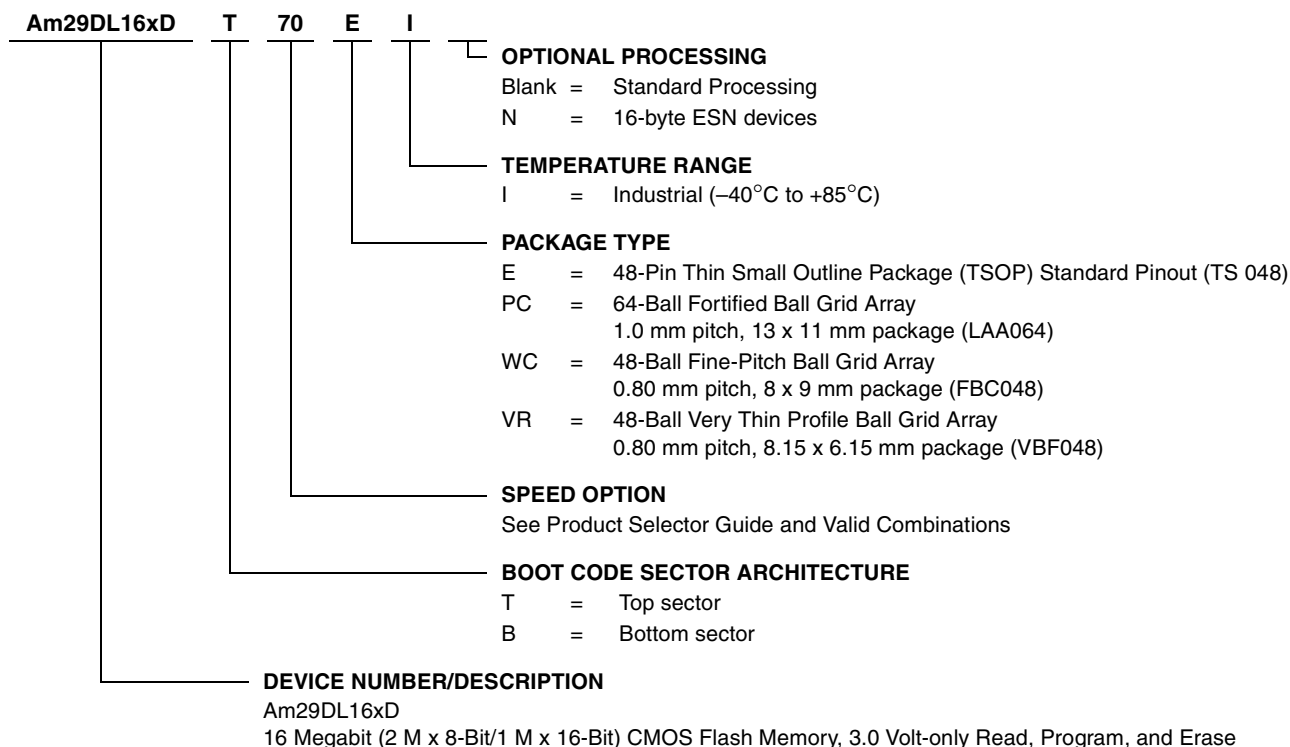

Valid Combinations for TSOP Packages	
Order Number	
AM29DL161DT70, AM29DL161DB70	EI
AM29DL162DT70, AM29DL162DB70	
AM29DL163DT70, AM29DL163DB70	
AM29DL164DT70, AM29DL164DB70	
AM29DL161DT90, AM29DL161DB90	
AM29DL162DT90, AM29DL162DB90	
AM29DL163DT90, AM29DL163DB90	
AM29DL164DT90, AM29DL164DB90	
AM29DL161DT120, AM29DL161DB120	
AM29DL162DT120, AM29DL162DB120	
AM29DL163DT120, AM29DL163DB120	
AM29DL164DT120, AM29DL164DB120	

Valid Combinations for FBGA Packages			
Order Number		Package Marking	
AM29DL161DT70, AM29DL161DB70	PCI, WCI, VRI	D161DT70, D161DB70	PI, VI, UI
AM29DL162DT70, AM29DL162DB70		D162DT70, D162DB70	
AM29DL163DT70, AM29DL163DB70		D163DT70, D163DB70	
AM29DL164DT70, AM29DL164DB70		D164DT70, D164DB70	
AM29DL161DT90, AM29DL161DB90		D161DT90, D161DB90	
AM29DL162DT90, AM29DL162DB90		D162DT90, D162DB90	
AM29DL163DT90, AM29DL163DB90		D163DT90, D163DB90	
AM29DL164DT90, AM29DL164DB90		D164DT90, D164DB90	
AM29DL161DT120, AM29DL161DB120		D161DT12, D161DB12	
AM29DL162DT120, AM29DL162DB120		D162DT12, D162DB12	
AM29DL163DT120, AM29DL163DB120		D163DT12, D163DB12	
AM29DL164DT120, AM29DL164DB120		D164DT12, D164DB12	

**Note:** Ordering numbers containing PCI are identified on device packages with PI. The same applies to WCI and VI, as well as VRI and UI.

#### Valid Combinations

Valid Combinations list configurations planned to be supported in volume for this device. Consult the local AMD sales office to confirm availability of specific valid combinations and to check on newly released combinations.

## DEVICE BUS OPERATIONS

This section describes the requirements and use of the device bus operations, which are initiated through the internal command register. The command register itself does not occupy any addressable memory location. The register is a latch used to store the commands, along with the address and data information needed to execute the command. The contents of

the register serve as inputs to the internal state machine. The state machine outputs dictate the function of the device. Table 1 lists the device bus operations, the inputs and control levels they require, and the resulting output. The following subsections describe each of these operations in further detail.

**Table 1. Am29DL16xD Device Bus Operations**

Operation	CE#	OE#	WE#	RESET#	WP#/ACC	Addresses (Note 2)	DQ0– DQ7	DQ8–DQ15	
								BYTE# = V <sub>IH</sub>	BYTE# = V <sub>IL</sub>
Read	L	L	H	H	L/H	A <sub>IN</sub>	D <sub>OUT</sub>	D <sub>OUT</sub>	DQ8–DQ14 = High-Z, DQ15 = A-1
Write	L	H	L	H	(Note 3)	A <sub>IN</sub>	D <sub>IN</sub>	D <sub>IN</sub>	
Standby	V <sub>CC</sub> ± 0.3 V	X	X	V <sub>CC</sub> ± 0.3 V	H	X	High-Z	High-Z	High-Z
Output Disable	L	H	H	H	L/H	X	High-Z	High-Z	High-Z
Reset	X	X	X	L	L/H	X	High-Z	High-Z	High-Z
Sector Protect (Note 2)	L	H	L	V <sub>ID</sub>	L/H	SA, A6 = L, A1 = H, A0 = L	D <sub>IN</sub>	X	X
Sector Unprotect (Note 2)	L	H	L	V <sub>ID</sub>	(Note 3)	SA, A6 = H, A1 = H, A0 = L	D <sub>IN</sub>	X	X
Temporary Sector Unprotect	X	X	X	V <sub>ID</sub>	(Note 3)	A <sub>IN</sub>	D <sub>IN</sub>	D <sub>IN</sub>	High-Z

**Legend:** L = Logic Low = V<sub>IL</sub>, H = Logic High = V<sub>IH</sub>, V<sub>ID</sub> = 8.5–12.5 V, V<sub>IH</sub> = 9.0 ± 0.5 V, X = Don't Care, SA = Sector Address, A<sub>IN</sub> = Address In, D<sub>IN</sub> = Data In, D<sub>OUT</sub> = Data Out

### Notes:

- Addresses are A19:A0 in word mode (BYTE# = V<sub>IH</sub>), A19:A-1 in byte mode (BYTE# = V<sub>IL</sub>).
- The sector protect and sector unprotect functions may also be implemented via programming equipment. See the "Sector/Sector Block Protection and Unprotection" section.
- If WP#/ACC = V<sub>IL</sub>, the two outermost boot sectors remain protected. If WP#/ACC = V<sub>IH</sub>, the two outermost boot sector protection depends on whether they were last protected or unprotected using the method described in "Sector/Sector Block Protection and Unprotection". If WP#/ACC = V<sub>IH</sub>, all sectors will be unprotected.

## Word/Byte Configuration

The BYTE# pin controls whether the device data I/O pins operate in the byte or word configuration. If the BYTE# pin is set at logic '1', the device is in word configuration, DQ0–DQ15 are active and controlled by CE# and OE#.

If the BYTE# pin is set at logic '0', the device is in byte configuration, and only data I/O pins DQ0–DQ7 are active and controlled by CE# and OE#. The data I/O pins DQ8–DQ14 are tri-stated, and the DQ15 pin is used as an input for the LSB (A-1) address function.

## Requirements for Reading Array Data

To read array data from the outputs, the system must drive the CE# and OE# pins to V<sub>IL</sub>. CE# is the power control and selects the device. OE# is the output control and gates array data to the output pins. WE# should remain at V<sub>IH</sub>. The BYTE# pin determines whether the device outputs array data in words or bytes.

The internal state machine is set for reading array data upon device power-up, or after a hardware reset. This ensures that no spurious alteration of the memory content occurs during the power transition. No command is necessary in this mode to obtain array data. Standard microprocessor read cycles that assert valid

addresses on the device address inputs produce valid data on the device data outputs. Each bank remains enabled for read access until the command register contents are altered.

See “Requirements for Reading Array Data” for more information. Refer to the AC Read-Only Operations table for timing specifications and to Figure 13 for the timing diagram.  $I_{CC1}$  in the DC Characteristics table represents the active current specification for reading array data.

## Writing Commands/Command Sequences

To write a command or command sequence (which includes programming data to the device and erasing sectors of memory), the system must drive WE# and CE# to  $V_{IL}$ , and OE# to  $V_{IH}$ .

For program operations, the BYTE# pin determines whether the device accepts program data in bytes or words. Refer to “Word/Byte Configuration” for more information.

The device features an **Unlock Bypass** mode to facilitate faster programming. Once a bank enters the Unlock Bypass mode, only two write cycles are required to program a word or byte, instead of four. The “Word/Byte Configuration” section has details on programming data to the device using both standard and Unlock Bypass command sequences.

An erase operation can erase one sector, multiple sectors, or the entire device. Tables 3–6 indicate the address space that each sector occupies. The device address space is divided into two banks: Bank 1 contains the boot/parameter sectors, and Bank 2 contains the larger, code sectors of uniform size. A “bank address” is the address bits required to uniquely select a bank. Similarly, a “sector address” is the address bits required to uniquely select a sector.

$I_{CC2}$  in the DC Characteristics table represents the active current specification for the write mode. The AC Characteristics section contains timing specification tables and timing diagrams for write operations.

## Accelerated Program Operation

The device offers accelerated program operations through the ACC function. This is one of two functions provided by the WP#/ACC pin. This function is primarily intended to allow faster manufacturing throughput at the factory.

If the system asserts  $V_{HH}$  on this pin, the device automatically enters the aforementioned Unlock Bypass mode, temporarily unprotects any protected sectors, and uses the higher voltage on the pin to reduce the time required for program operations. The system would use a two-cycle program command sequence as required by the Unlock Bypass mode. Removing

$V_{HH}$  from the WP#/ACC pin returns the device to normal operation. Note that the WP#/ACC pin must not be at  $V_{HH}$  for operations other than accelerated programming, or device damage may result. In addition, the WP#/ACC pin must not be left floating or unconnected; inconsistent behavior of the device may result.

## Autoselect Functions

If the system writes the autoselect command sequence, the device enters the autoselect mode. The system can then read autoselect codes from the internal register (which is separate from the memory array) on DQ7–DQ0. Standard read cycle timings apply in this mode. Refer to the Autoselect Mode and Autoselect Command Sequence sections for more information.

## Simultaneous Read/Write Operations with Zero Latency

This device is capable of reading data from one bank of memory while programming or erasing in the other bank of memory. An erase operation may also be suspended to read from or program to another location within the same bank (except the sector being erased). Figure 20 shows how read and write cycles may be initiated for simultaneous operation with zero latency.  $I_{CC6}$  and  $I_{CC7}$  in the DC Characteristics table represent the current specifications for read-while-program and read-while-erase, respectively.

## Standby Mode

When the system is not reading or writing to the device, it can place the device in the standby mode. In this mode, current consumption is greatly reduced, and the outputs are placed in the high impedance state, independent of the OE# input.

The device enters the CMOS standby mode when the CE# and RESET# pins are both held at  $V_{CC} \pm 0.3$  V. (Note that this is a more restricted voltage range than  $V_{IH}$ .) If CE# and RESET# are held at  $V_{IH}$ , but not within  $V_{CC} \pm 0.3$  V, the device will be in the standby mode, but the standby current will be greater. The device requires standard access time ( $t_{CE}$ ) for read access when the device is in either of these standby modes, before it is ready to read data.

If the device is deselected during erasure or programming, the device draws active current until the operation is completed.

$I_{CC3}$  in the DC Characteristics table represents the standby current specification.

## Automatic Sleep Mode

The automatic sleep mode minimizes Flash device energy consumption. The device automatically enables this mode when addresses remain stable for  $t_{ACC} +$

30 ns. The automatic sleep mode is independent of the CE#, WE#, and OE# control signals. Standard address access timings provide new data when addresses are changed. While in sleep mode, output data is latched and always available to the system.  $I_{CC4}$  in the DC Characteristics table represents the automatic sleep mode current specification.

### RESET#: Hardware Reset Pin

The RESET# pin provides a hardware method of resetting the device to reading array data. When the RESET# pin is driven low for at least a period of  $t_{RP}$ , the device immediately terminates any operation in progress, tristates all output pins, and ignores all read/write commands for the duration of the RESET# pulse. The device also resets the internal state machine to reading array data. The operation that was interrupted should be reinitiated once the device is ready to accept another command sequence, to ensure data integrity.

Current is reduced for the duration of the RESET# pulse. When RESET# is held at  $V_{SS} \pm 0.3$  V, the device draws CMOS standby current ( $I_{CC4}$ ). If RESET# is held at  $V_{IL}$  but not within  $V_{SS} \pm 0.3$  V, the standby current will be greater.

The RESET# pin may be tied to the system reset circuitry. A system reset would thus also reset the Flash memory, enabling the system to read the boot-up firmware from the Flash memory.

If RESET# is asserted during a program or erase operation, the RY/BY# pin remains a “0” (busy) until the internal reset operation is complete, which requires a time of  $t_{READY}$  (during Embedded Algorithms). The system can thus monitor RY/BY# to determine whether the reset operation is complete. If RESET# is asserted when a program or erase operation is not executing (RY/BY# pin is “1”), the reset operation is completed within a time of  $t_{READY}$  (not during Embedded Algorithms). The system can read data  $t_{RH}$  after the RESET# pin returns to  $V_{IH}$ .

Refer to the AC Characteristics tables for RESET# parameters and to Figure 14 for the timing diagram.

### Output Disable Mode

When the OE# input is at  $V_{IH}$ , output from the device is disabled. The output pins are placed in the high impedance state.

**Table 2. Am29DL16xD Device Bank Divisions**

Device Part Number	Bank 1		Bank 2	
	Megabits	Sector Sizes	Megabits	Sector Sizes
Am29DL161D	0.5 Mbit	Eight 8 Kbyte/4 Kword	15.5 Mbit	Thirty-one 64 Kbyte/32 Kword
Am29DL162D	2 Mbit	Eight 8 Kbyte/4 Kword, three 64 Kbyte/32 Kword	14 Mbit	Twenty-eight 64 Kbyte/32 Kword
Am29DL163D	4 Mbit	Eight 8 Kbyte/4 Kword, seven 64 Kbyte/32 Kword	12 Mbit	Twenty-four 64 Kbyte/32 Kword
Am29DL164D	8 Mbit	Eight 8 Kbyte/4 Kword, fifteen 64 Kbyte/32 Kword	8 Mbit	Sixteen 64 Kbyte/32 Kword

**Table 3. Sector Addresses for Top Boot Sector Devices**

Am29DL164DT	Am29DL163DT	Am29DL162DT	Am29DL161DT	Sector	Sector Address A19–A12	Sector Size (Kbytes/Kwords)	(x8) Address Range	(x16) Address Range
Bank 2	Bank 2	Bank 2	Bank 2	SA0	00000xxx	64/32	000000h-00FFFFh	00000h-07FFFh
				SA1	00001xxx	64/32	010000h-01FFFFh	08000h-0FFFFh
				SA2	00010xxx	64/32	020000h-02FFFFh	10000h-17FFFh
				SA3	00011xxx	64/32	030000h-03FFFFh	18000h-1FFFFh
				SA4	00100xxx	64/32	040000h-04FFFFh	20000h-27FFFh
				SA5	00101xxx	64/32	050000h-05FFFFh	28000h-2FFFFh
				SA6	00110xxx	64/32	060000h-06FFFFh	30000h-37FFFh
				SA7	00111xxx	64/32	070000h-07FFFFh	38000h-3FFFFh
				SA8	01000xxx	64/32	080000h-08FFFFh	40000h-47FFFh
				SA9	01001xxx	64/32	090000h-09FFFFh	48000h-4FFFFh
				SA10	01010xxx	64/32	0A0000h-0AFFFFh	50000h-57FFFh
				SA11	01011xxx	64/32	0B0000h-0BFFFFh	58000h-5FFFFh
				SA12	01100xxx	64/32	0C0000h-0CFFFFh	60000h-67FFFh
				SA13	01101xxx	64/32	0D0000h-0DFFFFh	68000h-6FFFFh
				SA14	01110xxx	64/32	0E0000h-0EFFFFh	70000h-77FFFh
				SA15	01111xxx	64/32	0F0000h-0FFFFFh	78000h-7FFFFh
				Bank 1	Bank 1	Bank 1	Bank 1	SA16
SA17	10001xxx	64/32	110000h-11FFFFh					88000h-8FFFFh
SA18	10010xxx	64/32	120000h-12FFFFh					90000h-97FFFh
SA19	10011xxx	64/32	130000h-13FFFFh					98000h-9FFFFh
SA20	10100xxx	64/32	140000h-14FFFFh					A0000h-A7FFFh
SA21	10101xxx	64/32	150000h-15FFFFh					A8000h-AFFFFh
SA22	10110xxx	64/32	160000h-16FFFFh					B0000h-B7FFFh
SA23	10111xxx	64/32	170000h-17FFFFh					B8000h-BFFFFh
SA24	11000xxx	64/32	180000h-18FFFFh					C0000h-C7FFFh
SA25	11001xxx	64/32	190000h-19FFFFh					C8000h-CFFFFh
SA26	11010xxx	64/32	1A0000h-1AFFFFh					D0000h-D7FFFh
SA27	11011xxx	64/32	1B0000h-1BFFFFh					D8000h-DFFFFh
SA28	11100xxx	64/32	1C0000h-1CFFFFh					E0000h-E7FFFh
SA29	11101xxx	64/32	1D0000h-1DFFFFh					E8000h-EFFFFh
SA30	11110xxx	64/32	1E0000h-1EFFFFh					F0000h-F7FFFh
SA31	11111000	8/4	1F0000h-1F1FFFh					F8000h-F8FFFh
SA32	11111001	8/4	1F2000h-1F3FFFh					F9000h-F9FFFh
SA33	11111010	8/4	1F4000h-1F5FFFh	FA000h-FAFFFh				
SA34	11111011	8/4	1F6000h-1F7FFFh	FB000h-FBFFFh				
SA35	11111100	8/4	1F8000h-1F9FFFh	FC000h-FCFFFh				
SA36	11111101	8/4	1FA000h-1FBFFFh	FD000h-FDFFFh				
SA37	11111110	8/4	1FC000h-1FDFFFh	FE000h-FEFFFh				
SA38	11111111	8/4	1FE000h-1FFFFFh	FF000h-FFFFFh				

**Note:** The address range is A19:A-1 in byte mode (BYTE#=V<sub>IL</sub>) or A19:A0 in word mode (BYTE#=V<sub>IH</sub>). The bank address bits are A19–A15 for Am29DL161DT, A19–A17 for Am29DL162DT, A19 and A18 for Am29DL163DT, and A19 for Am29DL164DT.

**Table 4. SecSi™ Sector Addresses for Top Boot Devices**

Device	Sector Address A19–A12	Sector Size	(x8) Address Range	(x16) Address Range
Am29DL16xDT	11111xxx	64/32	1F0000h-1FFFFFh	F8000h-FFFFFh

**Table 5. Sector Addresses for Bottom Boot Sector Devices**

Am29DL164DB	Am29DL163DB	Am29DL162DB	Am29DL161DB	Sector	Sector Address A19–A12	Sector Size (Kbytes/Kwords)	(x8) Address Range	(x16) Address Range	
Bank 1	Bank 1	Bank 1	Bank 1	SA0	00000000	8/4	000000h-001FFFh	00000h-00FFFh	
				SA1	00000001	8/4	002000h-003FFFh	01000h-01FFFh	
				SA2	00000010	8/4	004000h-005FFFh	02000h-02FFFh	
				SA3	00000011	8/4	006000h-007FFFh	03000h-03FFFh	
				SA4	00000100	8/4	008000h-009FFFh	04000h-04FFFh	
				SA5	00000101	8/4	00A000h-00BFFFh	05000h-05FFFh	
				SA6	00000110	8/4	00C000h-00DFFFh	06000h-06FFFh	
	SA7	00000111	8/4	00E000h-00FFFFh	07000h-07FFFh				
	Bank 2	Bank 2	Bank 2	Bank 2	SA8	00001XXX	64/32	010000h-01FFFFh	08000h-0FFFFh
					SA9	00010XXX	64/32	020000h-02FFFFh	10000h-17FFFh
					SA10	00011XXX	64/32	030000h-03FFFFh	18000h-1FFFFh
					SA11	00100XXX	64/32	040000h-04FFFFh	20000h-27FFFh
					SA12	00101XXX	64/32	050000h-05FFFFh	28000h-2FFFFh
					SA13	00110XXX	64/32	060000h-06FFFFh	30000h-37FFFh
					SA14	00111XXX	64/32	070000h-07FFFFh	38000h-3FFFFh
					SA15	01000XXX	64/32	080000h-08FFFFh	40000h-47FFFh
					SA16	01001XXX	64/32	090000h-09FFFFh	48000h-4FFFFh
					SA17	01010XXX	64/32	0A0000h-0AFFFFh	50000h-57FFFh
					SA18	01011XXX	64/32	0B0000h-0BFFFFh	58000h-5FFFFh
SA19					01100XXX	64/32	0C0000h-0CFFFFh	60000h-67FFFh	
SA20		01101XXX	64/32	0D0000h-0DFFFFh	68000h-6FFFFh				
SA21		01110XXX	64/32	0E0000h-0EFFFFh	70000h-77FFFh				
SA22		01111XXX	64/32	0F0000h-0FFFFFh	78000h-7FFFFh				
SA23		10000XXX	64/32	100000h-10FFFFh	80000h-87FFFh				
SA24		10001XXX	64/32	110000h-11FFFFh	88000h-8FFFFh				
SA25		10010XXX	64/32	120000h-12FFFFh	90000h-97FFFh				
SA26		10011XXX	64/32	130000h-13FFFFh	98000h-9FFFFh				
SA27		10100XXX	64/32	140000h-14FFFFh	A0000h-A7FFFh				
SA28		10101XXX	64/32	150000h-15FFFFh	A8000h-AFFFFh				
SA29		10110XXX	64/32	160000h-16FFFFh	B0000h-B7FFFh				
SA30		10111XXX	64/32	170000h-17FFFFh	B8000h-BFFFFh				
SA31		11000XXX	64/32	180000h-18FFFFh	C0000h-C7FFFh				
SA32		11001XXX	64/32	190000h-19FFFFh	C8000h-CFFFFh				
SA33		11010XXX	64/32	1A0000h-1AFFFFh	D0000h-D7FFFh				
SA34		11011XXX	64/32	1B0000h-1BFFFFh	D8000h-DFFFFh				
SA35		11100XXX	64/32	1C0000h-1CFFFFh	E0000h-E7FFFh				
SA36		11101XXX	64/32	1D0000h-1DFFFFh	E8000h-EFFFFh				
SA37		11110XXX	64/32	1E0000h-1EFFFFh	F0000h-F7FFFh				
SA38		11111XXX	64/32	1F0000h-1FFFFFh	F8000h-FFFFFh				

**Note:** The address range is A19:A-1 in byte mode (BYTE#=V<sub>IL</sub>) or A19:A0 in word mode (BYTE#=V<sub>IH</sub>). The bank address bits are A19–A15 for Am29DL161DB, A19–A17 for Am29DL162DB, A19 and A18 for Am29DL163DB, and A19 for Am29DL164DB.

**Table 6. SecSi™ Addresses for Bottom Boot Devices**

Device	Sector Address A19–A12	Sector Size	(x8) Address Range	(x16) Address Range
Am29DL16xDB	00000XXX	64/32	000000h-00FFFFh	00000h-07FFFh



## Autoselect Mode

The autoselect mode provides manufacturer and device identification, and sector protection verification, through identifier codes output on DQ7–DQ0. This mode is primarily intended for programming equipment to automatically match a device to be programmed with its corresponding programming algorithm. However, the autoselect codes can also be accessed in-system through the command register.

When using programming equipment, the autoselect mode requires  $V_{ID}$  (8.5 V to 12.5 V) on address pin A9. Address pins A6, A1, and A0 must be as shown in

Table 7. In addition, when verifying sector protection, the sector address must appear on the appropriate highest order address bits (see Tables 3–6). Table 7 shows the remaining address bits that are don't care. When all necessary bits have been set as required, the programming equipment may then read the corresponding identifier code on DQ7–DQ0.

To access the autoselect codes in-system, the host system can issue the autoselect command via the command register, as shown in Table 14. This method does not require  $V_{ID}$ . Refer to the Autoselect Command Sequence section for more information.

**Table 7. Am29DL16xD Autoselect Codes, (High Voltage Method)**

Description	CE#	OE#	WE#	A19 to A12	A11 to A10	A9	A8 to A7	A6	A5 to A2	A1	A0	DQ8 to DQ15		DQ7 to DQ0
												BYTE# = $V_{IH}$	BYTE# = $V_{IL}$	
Manufacturer ID: AMD	L	L	H	BA	X	$V_{ID}$	X	L	X	L	L	X	X	01h
Device ID: Am29DL161D	L	L	H	BA	X	$V_{ID}$	X	L	X	L	H	22h	X	36h (T), 39h (B)
Device ID: Am29DL162D	L	L	H	BA	X	$V_{ID}$	X	L	X	L	H	22h	X	2Dh (T), 2Eh (B)
Device ID: Am29DL163D	L	L	H	BA	X	$V_{ID}$	X	L	X	L	H	22h	X	28h (T), 2Bh (B)
Device ID: Am29DL164D	L	L	H	BA	X	$V_{ID}$	X	L	X	L	H	22h	X	33h (T), 35h (B)
Sector Protection Verification	L	L	H	SA	X	$V_{ID}$	X	L	X	H	L	X	X	01h (protected), 00h (unprotected)
SecSi™ Indicator Bit (DQ7)	L	L	H	BA	X	$V_{ID}$	X	L	X	H	H	X	X	81h (factory locked), 01h (not factory locked)

**Legend:** T = Top Boot Block, B = Bottom Boot Block, L = Logic Low =  $V_{IL}$ , H = Logic High =  $V_{IH}$ , BA = Bank Address, SA = Sector Address, X = Don't care.

## Sector/Sector Block Protection and Unprotection

(Note: For the following discussion, the term “sector” applies to both sectors and sector blocks. A sector block consists of two or more adjacent sectors that are protected or unprotected at the same time (see Tables 8 and 9).

**Table 8. Top Boot Sector/Sector Block Addresses for Protection/Unprotection**

Sector / Sector Block	A19–A12	Sector / Sector Block Size
SA0	00000XXX	64 Kbytes
SA1-SA3	00001XXX, 00010XXX, 00011XXX	192 (3x64) Kbytes
SA4-SA7	001XXXXX	256 (4x64) Kbytes
SA8-SA11	010XXXXX	256 (4x64) Kbytes
SA12-SA15	011XXXXX	256 (4x64) Kbytes
SA16-SA19	100XXXXX	256 (4x64) Kbytes
SA20-SA23	101XXXXX	256 (4x64) Kbytes
SA24-SA27	110XXXXX	256 (4x64) Kbytes
SA28-SA30	11100XXX, 11101XXX, 11110XXX	192 (3x64) Kbytes
SA31	11111000	8 Kbytes
SA32	11111001	8 Kbytes
SA33	11111010	8 Kbytes
SA34	11111011	8 Kbytes
SA35	11111100	8 Kbytes
SA36	11111101	8 Kbytes
SA37	11111110	8 Kbytes
SA38	11111111	8 Kbytes

**Table 9. Bottom Boot Sector/Sector Block Addresses for Protection/Unprotection**

Sector / Sector Block	A19–A12	Sector / Sector Block Size
SA38	11111XXX	64 Kbytes
SA37-SA35	11110XXX, 11101XXX, 11100XXX	192 (3x64) Kbytes
SA34-SA31	110XXXXX	256 (4x64) Kbytes
SA30-SA27	101XXXXX	256 (4x64) Kbytes
SA26-SA23	100XXXXX	256 (4x64) Kbytes
SA22-SA19	011XXXXX	256 (4x64) Kbytes
SA18-SA15	010XXXXX	256 (4x64) Kbytes
SA14-SA11	001XXXXX	256 (4x64) Kbytes
SA10-SA8	00001XXX, 00010XXX, 00011XXX	192 (3x64) Kbytes
SA7	00000111	8 Kbytes
SA6	00000110	8 Kbytes
SA5	00000101	8 Kbytes
SA4	00000100	8 Kbytes
SA3	00000011	8 Kbytes
SA2	00000010	8 Kbytes
SA1	00000001	8 Kbytes
SA0	00000000	8 Kbytes

The hardware sector protection feature disables both program and erase operations in any sector. The hardware sector unprotection feature re-enables both program and erase operations in previously protected sectors. Sector protection and unprotection can be implemented via two methods.

The primary method requires  $V_{ID}$  on the RESET# pin only, and can be implemented either in-system or via programming equipment. Figure 2 shows the algorithms and Figure 25 shows the timing diagram. This method uses standard microprocessor bus cycle timing. For sector unprotect, all unprotected sectors must first be protected prior to the first sector unprotect write cycle.

The sector unprotect algorithm unprotects all sectors in parallel. All previously protected sectors must be individually re-protected. To change data in protected sectors efficiently, the temporary sector unprotect function is available. See “Temporary Sector/Sector Block Unprotect”.

The alternate method intended only for programming equipment requires  $V_{ID}$  on address pin A9 and OE#. This method is compatible with programmer routines written for earlier 3.0 volt-only AMD flash devices. Publication number 22243 contains further details; contact an AMD representative to request a copy.

The device is shipped with all sectors unprotected. AMD offers the option of programming and protecting sectors at its factory prior to shipping the device

through AMD's ExpressFlash™ Service. Contact an AMD representative for details.

It is possible to determine whether a sector is protected or unprotected. See the Autoselect Mode section for details.

### Write Protect (WP#)

The Write Protect function provides a hardware method of protecting certain boot sectors without using  $V_{ID}$ . This function is one of two provided by the WP#/ACC pin.

If the system asserts  $V_{IL}$  on the WP#/ACC pin, the device disables program and erase functions in the two "outermost" 8 Kbyte boot sectors independently of whether those sectors were protected or unprotected using the method described in "Sector/Sector Block Protection and Unprotection". The two outermost 8 Kbyte boot sectors are the two sectors containing the lowest addresses in a bottom-boot-configured device, or the two sectors containing the highest addresses in a top-boot-configured device.

If the system asserts  $V_{IH}$  on the WP#/ACC pin, the device reverts to whether the two outermost 8 Kbyte boot sectors were last set to be protected or unprotected. That is, sector protection or unprotection for these two sectors depends on whether they were last protected or unprotected using the method described in "Sector/Sector Block Protection and Unprotection".

Note that the WP#/ACC pin must not be left floating or unconnected; inconsistent behavior of the device may result.

### Temporary Sector/Sector Block Unprotect

(Note: For the following discussion, the term "sector" applies to both sectors and sector blocks. A sector block consists of two or more adjacent sectors that are protected or unprotected at the same time (see Tables 8 and 9).

This feature allows temporary unprotection of previously protected sectors to change data in-system. The Sector Unprotect mode is activated by setting the RESET# pin to  $V_{ID}$  (8.5 V – 12.5 V). During this mode, formerly protected sectors can be programmed or erased by selecting the sector addresses. Once  $V_{ID}$  is removed from the RESET# pin, all the previously protected sectors are protected again. Figure 1 shows the algorithm, and Figure 24 shows the timing diagrams, for this feature.

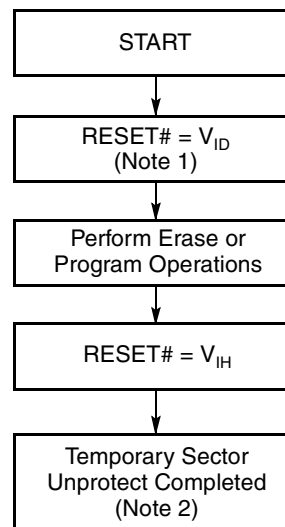

#### Notes:

1. All protected sectors unprotected (If WP#/ACC =  $V_{IL}$ , outermost boot sectors will remain protected).
2. All previously protected sectors are protected once again.

Figure 1. Temporary Sector Unprotect Operation

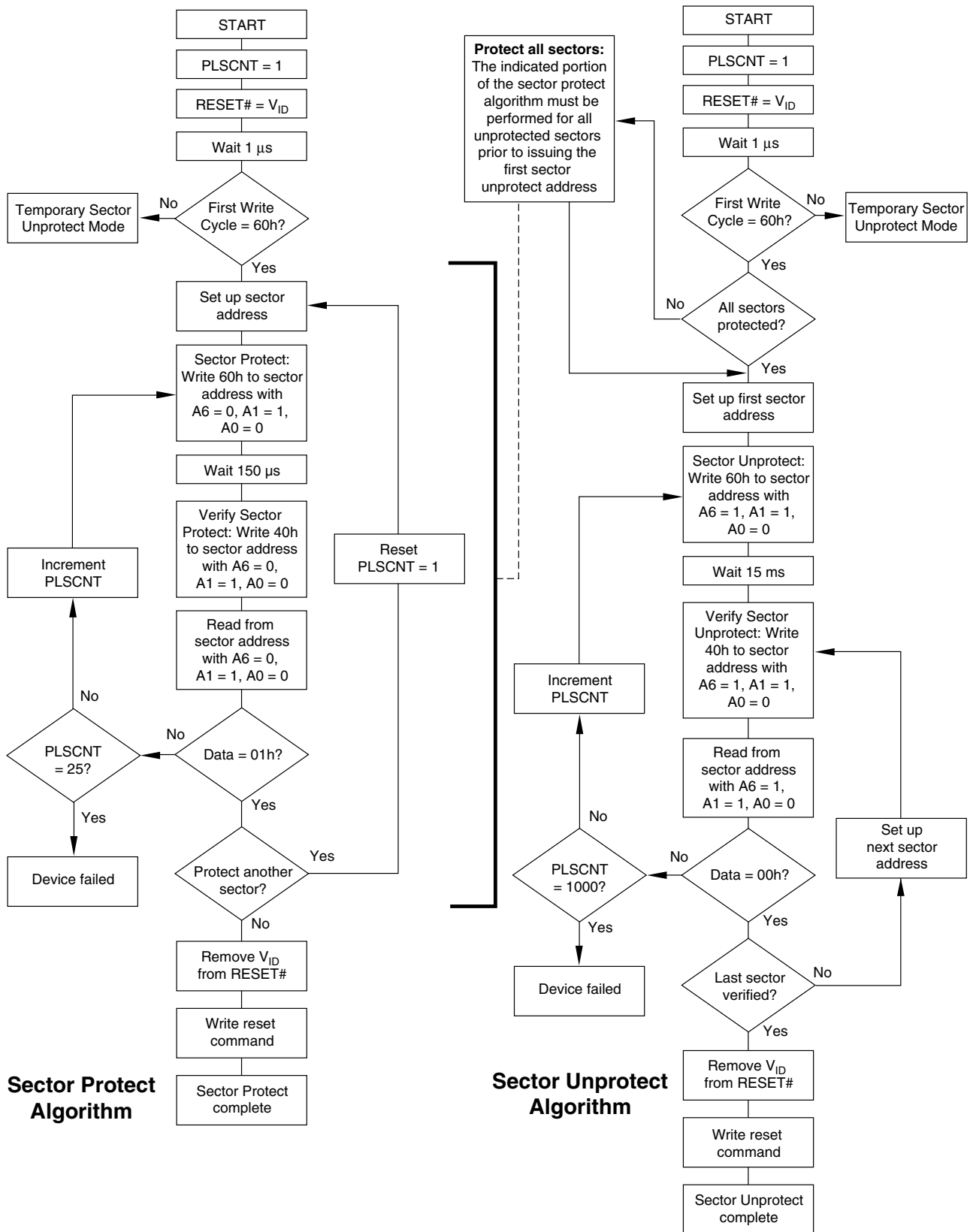

Note: The term "sector" in the figure applies to both sectors and sector blocks.

Figure 2. In-System Sector/Sector Block Protection and Unprotection Algorithms

## SecSi™ (Secured Silicon) Sector Flash Memory Region

The SecSi (Secured Silicon) Sector feature provides a Flash memory region that enables permanent part identification through an Electronic Serial Number (ESN). The SecSi Sector uses an Indicator Bit (DQ7) to indicate whether or not the sector is locked when shipped from the factory. This bit is permanently set at the factory and cannot be changed, which prevents cloning of a factory locked part. This ensures the security of the ESN once the product is shipped to the field. **Current version of device has 64 Kbytes; future versions will have only 256 bytes. This should be considered during system design.**

AMD offers the device with the SecSi Sector either factory locked or customer lockable. The factory-locked version is always protected when shipped from the factory, and has the SecSi Sector Indicator Bit permanently set to a “1.” The customer-lockable version is shipped with the unprotected, allowing customers to utilize the that sector in any manner they choose. The customer-lockable version has the SecSi Sector Indicator Bit permanently set to a “0.” Thus, the SecSi Sector Indicator Bit prevents customer-lockable devices from being used to replace devices that are factory locked.

The system accesses the SecSi Sector through a command sequence (see “Enter SecSi Sector/Exit SecSi Sector Command Sequence”). After the system has written the Enter SecSi Sector command sequence, it may read the SecSi Sector by using the addresses normally occupied by the boot sectors. This mode of operation continues until the system issues the Exit SecSi Sector command sequence, or until power is removed from the device. On power-up, or following a hardware reset, the device reverts to sending commands to the boot sectors.

### Factory Locked: SecSi Sector Programmed and Protected At the Factory

In a factory locked device, the SecSi Sector is protected when the device is shipped from the factory. The SecSi Sector cannot be modified in any way. The device is available preprogrammed with one of the following:

- A random, secure ESN only
- Customer code through the ExpressFlash service
- Both a random, secure ESN and customer code through the ExpressFlash service.

In devices that have an ESN, a Bottom Boot device will have the 16-byte ESN in the lowest addressable memory area at addresses 00000h–00007h in word mode (or 000000h–00000Fh in byte mode). In the Top Boot device the starting address of the ESN will be at the

bottom of the lowest 8 Kbyte boot sector at addresses F8000h–F8007h in word mode (or 1F0000h–1F000Fh in byte mode).

Customers may opt to have their code programmed by AMD through the AMD ExpressFlash service. AMD programs the customer’s code, with or without the random ESN. The devices are then shipped from AMD’s factory with the SecSi Sector permanently locked. Contact an AMD representative for details on using AMD’s ExpressFlash service.

### Customer Lockable: SecSi Sector NOT Programmed or Protected At the Factory

If the security feature is not required, the SecSi Sector can be treated as an additional Flash memory space, expanding the size of the available Flash array. **Current version of device has 64 Kbytes; future versions will have only 256 bytes. This should be considered during system design.** The SecSi Sector can be read, programmed, and erased as often as required. (*Note that in upcoming versions of this device, the SecSi Sector erase function will not be available.*) Note that the accelerated programming (ACC) and unlock bypass functions are not available when programming the SecSi Sector.

The SecSi Sector area can be protected using one of the following procedures:

- Write the three-cycle Enter SecSi Sector Region command sequence, and then follow the in-system sector protect algorithm as shown in Figure 2, except that *RESET#* may be at either  $V_{IH}$  or  $V_{ID}$ . This allows in-system protection of the without raising any device pin to a high voltage. Note that this method is only applicable to the SecSi Sector.
- Write the three-cycle Enter SecSi Sector Region command sequence, and then use the alternate method of sector protection described in the “Sector/Sector Block Protection and Unprotection”.

Once the SecSi Sector is locked and verified, the system must write the Exit SecSi Sector Region command sequence to return to reading and writing the remainder of the array.

The SecSi Sector protection must be used with caution since, once protected, there is no procedure available for unprotecting the SecSi Sector area and none of the bits in the SecSi Sector memory space can be modified in any way.

### Hardware Data Protection

The command sequence requirement of unlock cycles for programming or erasing provides data protection against inadvertent writes (refer to Table 14 for command definitions). In addition, the following hardware data protection measures prevent accidental erasure or programming, which might otherwise be caused by

spurious system level signals during  $V_{CC}$  power-up and power-down transitions, or from system noise.

#### Low $V_{CC}$ Write Inhibit

When  $V_{CC}$  is less than  $V_{LKO}$ , the device does not accept any write cycles. This protects data during  $V_{CC}$  power-up and power-down. The command register and all internal program/erase circuits are disabled, and the device resets to reading array data. Subsequent writes are ignored until  $V_{CC}$  is greater than  $V_{LKO}$ . The system must provide the proper signals to the control pins to prevent unintentional writes when  $V_{CC}$  is greater than  $V_{LKO}$ .

#### Write Pulse “Glitch” Protection

Noise pulses of less than 5 ns (typical) on OE#, CE# or WE# do not initiate a write cycle.

#### Logical Inhibit

Write cycles are inhibited by holding any one of OE# =  $V_{IL}$ , CE# =  $V_{IH}$  or WE# =  $V_{IH}$ . To initiate a write cycle, CE# and WE# must be a logical zero while OE# is a logical one.

#### Power-Up Write Inhibit

If WE# = CE# =  $V_{IL}$  and OE# =  $V_{IH}$  during power up, the device does not accept commands on the rising edge of WE#. The internal state machine is automatically reset to reading array data on power-up.

## COMMON FLASH MEMORY INTERFACE (CFI)

The Common Flash Interface (CFI) specification outlines device and host system software interrogation handshake, which allows specific vendor-specified software algorithms to be used for entire families of devices. Software support can then be device-independent, JEDEC ID-independent, and forward- and backward-compatible for the specified flash device families. Flash vendors can standardize their existing interfaces for long-term compatibility.

This device enters the CFI Query mode when the system writes the CFI Query command, 98h, to address 55h in word mode (or address AAh in byte mode), any time the device is ready to read array data. The system can read CFI information at the addresses given in Tables 10–13. To terminate reading CFI data, the system must write the reset command.

The system can also write the CFI query command when the device is in the autoselect mode. The device enters the CFI query mode, and the system can read CFI data at the addresses given in Tables 10–13. The system must write the reset command to return the device to the autoselect mode.

For further information, please refer to the CFI Specification and CFI Publication 100, available via the World Wide Web at <http://www.amd.com/products/nvd/overview/cfi.html>. Alternatively, contact an AMD representative for copies of these documents.

**Table 10. CFI Query Identification String**

Addresses (Word Mode)	Addresses (Byte Mode)	Data	Description
10h 11h 12h	20h 22h 24h	0051h 0052h 0059h	Query Unique ASCII string “QRY”
13h 14h	26h 28h	0002h 0000h	Primary OEM Command Set
15h 16h	2Ah 2Ch	0040h 0000h	Address for Primary Extended Table
17h 18h	2Eh 30h	0000h 0000h	Alternate OEM Command Set (00h = none exists)
19h 1Ah	32h 34h	0000h 0000h	Address for Alternate OEM Extended Table (00h = none exists)

Table 11. System Interface String

Addresses (Word Mode)	Addresses (Byte Mode)	Data	Description
1Bh	36h	0027h	V <sub>CC</sub> Min. (write/erase) D7–D4: volt, D3–D0: 100 millivolt
1Ch	38h	0036h	V <sub>CC</sub> Max. (write/erase) D7–D4: volt, D3–D0: 100 millivolt
1Dh	3Ah	0000h	V <sub>PP</sub> Min. voltage (00h = no V <sub>PP</sub> pin present)
1Eh	3Ch	0000h	V <sub>PP</sub> Max. voltage (00h = no V <sub>PP</sub> pin present)
1Fh	3Eh	0004h	Typical timeout per single byte/word write 2 <sup>N</sup> μs
20h	40h	0000h	Typical timeout for Min. size buffer write 2 <sup>N</sup> μs (00h = not supported)
21h	42h	000Ah	Typical timeout per individual block erase 2 <sup>N</sup> ms
22h	44h	0000h	Typical timeout for full chip erase 2 <sup>N</sup> ms (00h = not supported)
23h	46h	0005h	Max. timeout for byte/word write 2 <sup>N</sup> times typical
24h	48h	0000h	Max. timeout for buffer write 2 <sup>N</sup> times typical
25h	4Ah	0004h	Max. timeout per individual block erase 2 <sup>N</sup> times typical
26h	4Ch	0000h	Max. timeout for full chip erase 2 <sup>N</sup> times typical (00h = not supported)

Table 12. Device Geometry Definition

Addresses (Word Mode)	Addresses (Byte Mode)	Data	Description
27h	4Eh	0015h	Device Size = 2 <sup>N</sup> byte
28h 29h	50h 52h	0002h 0000h	Flash Device Interface description (refer to CFI publication 100)
2Ah 2Bh	54h 56h	0000h 0000h	Max. number of bytes in multi-byte write = 2 <sup>N</sup> (00h = not supported)
2Ch	58h	0002h	Number of Erase Block Regions within device
2Dh 2Eh 2Fh 30h	5Ah 5Ch 5Eh 60h	0007h 0000h 0020h 0000h	Erase Block Region 1 Information (refer to the CFI specification or CFI publication 100)
31h 32h 33h 34h	62h 64h 66h 68h	001Eh 0000h 0000h 0001h	Erase Block Region 2 Information
35h 36h 37h 38h	6Ah 6Ch 6Eh 70h	0000h 0000h 0000h 0000h	Erase Block Region 3 Information
39h 3Ah 3Bh 3Ch	72h 74h 76h 78h	0000h 0000h 0000h 0000h	Erase Block Region 4 Information



**Table 13. Primary Vendor-Specific Extended Query**

Addresses (Word Mode)	Addresses (Byte Mode)	Data	Description
40h 41h 42h	80h 82h 84h	0050h 0052h 0049h	Query-unique ASCII string "PRI"
43h	86h	0031h	Major version number, ASCII
44h	88h	0031h	Minor version number, ASCII
45h	8Ah	0000h	Address Sensitive Unlock (Bits 1-0) 0 = Required, 1 = Not Required Silicon Revision Number (Bits 7-2)
46h	8Ch	0002h	Erase Suspend 0 = Not Supported, 1 = To Read Only, 2 = To Read & Write
47h	8Eh	0001h	Sector Protect 0 = Not Supported, X = Number of sectors in per group
48h	90h	0001h	Sector Temporary Unprotect 00 = Not Supported, 01 = Supported
49h	92h	0004h	Sector Protect/Unprotect scheme 04 = 29LV800 mode
4Ah	94h	00XXh (See Note)	Simultaneous Operation 00 = Not Supported, X= Number of Sectors in Bank 2 (Uniform Bank)
4Bh	96h	0000h	Burst Mode Type 00 = Not Supported, 01 = Supported
4Ch	98h	0000h	Page Mode Type 00 = Not Supported, 01 = 4 Word Page, 02 = 8 Word Page
4Dh	9Ah	0085h	ACC (Acceleration) Supply Minimum 00h = Not Supported, D7-D4: Volt, D3-D0: 100 mV
4Eh	9Ch	0095h	ACC (Acceleration) Supply Maximum 00h = Not Supported, D7-D4: Volt, D3-D0: 100 mV
4Fh	9Eh	000Xh	Top/Bottom Boot Sector Flag 02h = Bottom Boot Device, 03h = Top Boot Device

*Note:*

*The number of sectors in Bank 2 is device dependent.*

*Am29DL161 = 1Fh*

*Am29DL162 = 1Ch*

*Am29DL163 = 18h*

*Am29DL164 = 10h*



## COMMAND DEFINITIONS

Writing specific address and data commands or sequences into the command register initiates device operations. Table 14 defines the valid register command sequences. *Writing **incorrect address and data values** or writing them in the **improper sequence** may place the device in an unknown state. A reset command is then required to return the device to reading array data.*

All addresses are latched on the falling edge of WE# or CE#, whichever happens later. All data is latched on the rising edge of WE# or CE#, whichever happens first. Refer to the AC Characteristics section for timing diagrams.

### Reading Array Data

The device is automatically set to reading array data after device power-up. No commands are required to retrieve data. Each bank is ready to read array data after completing an Embedded Program or Embedded Erase algorithm.

After the device accepts an Erase Suspend command, the corresponding bank enters the erase-suspend-read mode, after which the system can read data from any non-erase-suspended sector within the same bank. After completing a programming operation in the Erase Suspend mode, the system may once again read array data with the same exception. See the Erase Suspend/Erase Resume Commands section for more information.

The system *must* issue the reset command to return a bank to the read (or erase-suspend-read) mode if DQ5 goes high during an active program or erase operation, or if the bank is in the autoselect mode. See the next section, Reset Command, for more information.

See also Requirements for Reading Array Data in the Device Bus Operations section for more information. The Read-Only Operations table provides the read parameters, and Figure 13 shows the timing diagram.

### Reset Command

Writing the reset command resets the banks to the read or erase-suspend-read mode. Address bits are don't cares for this command.

The reset command may be written between the sequence cycles in an erase command sequence before erasing begins. This resets the bank to which the system was writing to reading array data. Once erasure begins, however, the device ignores reset commands until the operation is complete.

The reset command may be written between the sequence cycles in a program command sequence before programming begins. This resets the bank to which the system was writing to reading array data. If

the program command sequence is written to a bank that is in the Erase Suspend mode, writing the reset command returns that bank to the erase-suspend-read mode. Once programming begins, however, the device ignores reset commands until the operation is complete.

The reset command may be written between the sequence cycles in an autoselect command sequence. Once in the autoselect mode, the reset command must be written to return to reading array data. If a bank entered the autoselect mode while in the Erase Suspend mode, writing the reset command returns that bank to the erase-suspend-read mode.

If DQ5 goes high during a program or erase operation, writing the reset command returns the banks to reading array data (or erase-suspend-read mode if that bank was in Erase Suspend).

### Autoselect Command Sequence

The autoselect command sequence allows the host system to access the manufacturer and device codes, and determine whether or not a sector is protected. Table 14 shows the address and data requirements. This method is an alternative to that shown in Table 7, which is intended for PROM programmers and requires  $V_{ID}$  on address pin A9. The autoselect command sequence may be written to an address within a bank that is either in the read or erase-suspend-read mode. The autoselect command may not be written while the device is actively programming or erasing in the other bank.

The autoselect command sequence is initiated by first writing two unlock cycles. This is followed by a third write cycle that contains the bank address and the autoselect command. The bank then enters the autoselect mode. The system may read at any address within the same bank any number of times without initiating another autoselect command sequence:

- A read cycle at address (BA)XX00h (where BA is the bank address) returns the manufacturer code.
- A read cycle at address (BA)XX01h in word mode (or (BA)XX02h in byte mode) returns the device code.
- A read cycle to an address containing a sector address (SA) within the same bank, and the address 02h on A7–A0 in word mode (or the address 04h on A6–A-1 in byte mode) returns 01h if the sector is protected, or 00h if it is unprotected. (Refer to Tables 3–6 for valid sector addresses).

The system must write the reset command to return to reading array data (or erase-suspend-read mode if the bank was previously in Erase Suspend).

## Enter SecSi™ Sector/Exit SecSi Sector Command Sequence

The system can access the SecSi Sector region by issuing the three-cycle Enter SecSi Sector command sequence. The device continues to access the SecSi Sector region until the system issues the four-cycle Exit SecSi Sector command sequence. The Exit SecSi Sector command sequence returns the device to normal operation. Table 14 shows the address and data requirements for both command sequences. See also “SecSi Sector Flash Memory Region” for further information. Note that a hardware reset ( $\text{RESET}\# = V_{IL}$ ) will reset the device to reading array data.

## Byte/Word Program Command Sequence

The system may program the device by word or byte, depending on the state of the BYTE# pin. Programming is a four-bus-cycle operation. The program command sequence is initiated by writing two unlock write cycles, followed by the program set-up command. The program address and data are written next, which in turn initiate the Embedded Program algorithm. The system is *not* required to provide further controls or timings. The device automatically provides internally generated program pulses and verifies the programmed cell margin. Table 14 shows the address and data requirements for the byte program command sequence.

When the Embedded Program algorithm is complete, that bank then returns to reading array data and addresses are no longer latched. The system can determine the status of the program operation by using DQ7, DQ6, or RY/BY#. Refer to the Write Operation Status section for information on these status bits.

Any commands written to the device during the Embedded Program Algorithm are ignored. Note that a **hardware reset** immediately terminates the program operation. The program command sequence should be reinitiated once that bank has returned to reading array data, to ensure data integrity.

Programming is allowed in any sequence and across sector boundaries. **A bit cannot be programmed from “0” back to a “1.”** Attempting to do so may cause that bank to set  $\text{DQ5} = 1$ , or cause the DQ7 and

DQ6 status bits to indicate the operation was successful. However, a succeeding read will show that the data is still “0.” Only erase operations can convert a “0” to a “1.”

## Unlock Bypass Command Sequence

The unlock bypass feature allows the system to program bytes or words to a bank faster than using the standard program command sequence. The unlock bypass command sequence is initiated by first writing two unlock cycles. This is followed by a third write cycle containing the unlock bypass command, 20h. The device then enters the unlock bypass mode. A two-cycle unlock bypass program command sequence is all that is required to program in this mode. The first cycle in this sequence contains the unlock bypass program command, A0h; the second cycle contains the program address and data. Additional data is programmed in the same manner. This mode dispenses with the initial two unlock cycles required in the standard program command sequence, resulting in faster total programming time. Table 14 shows the requirements for the command sequence.

During the unlock bypass mode, only the Unlock Bypass Program and Unlock Bypass Reset commands are valid. To exit the unlock bypass mode, the system must issue the two-cycle unlock bypass reset command sequence. The device then returns to reading array data.

The device offers accelerated program operations through the WP#/ACC pin. When the system asserts  $V_{HH}$  on the WP#/ACC pin, the device automatically enters the Unlock Bypass mode. The system may then write the two-cycle Unlock Bypass program command sequence. The device uses the higher voltage on the WP#/ACC pin to accelerate the operation. Note that the WP#/ACC pin must not be at  $V_{HH}$  any operation other than accelerated programming, or device damage may result. In addition, the WP#/ACC pin must not be left floating or unconnected; inconsistent behavior of the device may result.

Figure 3 illustrates the algorithm for the program operation. Refer to the Erase and Program Operations table in the AC Characteristics section for parameters, and Figure 17 for timing diagrams.

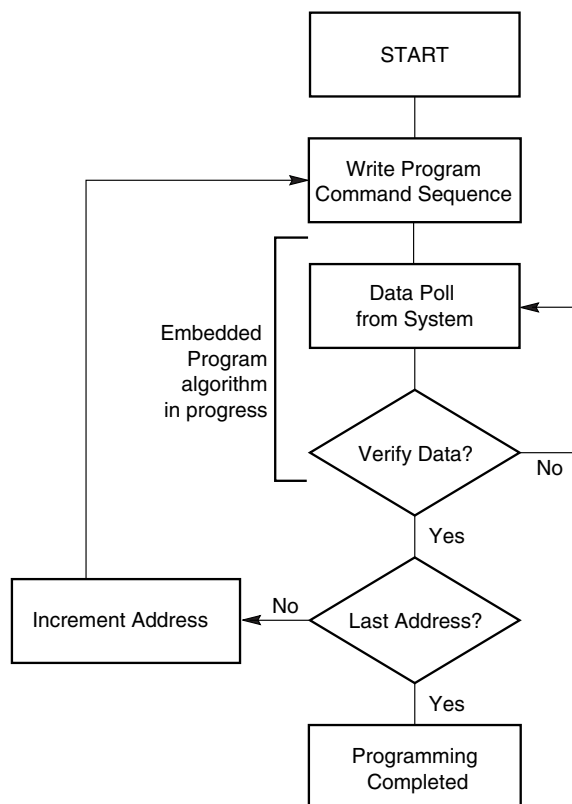

**Note:** See Table 14 for program command sequence.

**Figure 3. Program Operation**

## Chip Erase Command Sequence

Chip erase is a six bus cycle operation. The chip erase command sequence is initiated by writing two unlock cycles, followed by a set-up command. Two additional unlock write cycles are then followed by the chip erase command, which in turn invokes the Embedded Erase algorithm. The device does *not* require the system to preprogram prior to erase. The Embedded Erase algorithm automatically preprograms and verifies the entire memory for an all zero data pattern prior to electrical erase. The system is not required to provide any controls or timings during these operations. Table 14 shows the address and data requirements for the chip erase command sequence.

When the Embedded Erase algorithm is complete, that bank returns to reading array data and addresses are no longer latched. The system can determine the status of the erase operation by using DQ7, DQ6, DQ2, or RY/BY#. Refer to the Write Operation Status section for information on these status bits.

Any commands written during the chip erase operation are ignored. However, note that a **hardware reset** im-

mediately terminates the erase operation. If that occurs, the chip erase command sequence should be reinitiated once that bank has returned to reading array data, to ensure data integrity.

Figure 4 illustrates the algorithm for the erase operation. Refer to the Erase and Program Operations tables in the AC Characteristics section for parameters, and Figure 19 section for timing diagrams.

## Sector Erase Command Sequence

Sector erase is a six bus cycle operation. The sector erase command sequence is initiated by writing two unlock cycles, followed by a set-up command. Two additional unlock cycles are written, and are then followed by the address of the sector to be erased, and the sector erase command. Table 14 shows the address and data requirements for the sector erase command sequence.

The device does *not* require the system to preprogram prior to erase. The Embedded Erase algorithm automatically programs and verifies the entire memory for an all zero data pattern prior to electrical erase. The system is not required to provide any controls or timings during these operations.

After the command sequence is written, a sector erase time-out of 50  $\mu$ s occurs. During the time-out period, additional sector addresses and sector erase commands within the bank may be written. Loading the sector erase buffer may be done in any sequence, and the number of sectors may be from one sector to all sectors. The time between these additional cycles must be less than 50  $\mu$ s, otherwise erasure may begin. Any sector erase address and command following the exceeded time-out may or may not be accepted. It is recommended that processor interrupts be disabled during this time to ensure all commands are accepted. The interrupts can be re-enabled after the last Sector Erase command is written. **Any command other than Sector Erase or Erase Suspend during the time-out period resets that bank to reading array data.** The system must rewrite the command sequence and any additional addresses and commands.

The system can monitor DQ3 to determine if the sector erase timer has timed out (See the section on DQ3: Sector Erase Timer.). The time-out begins from the rising edge of the final WE# pulse in the command sequence.

When the Embedded Erase algorithm is complete, the bank returns to reading array data and addresses are no longer latched. Note that while the Embedded Erase operation is in progress, the system can read data from the non-erasing bank. The system can determine the status of the erase operation by reading DQ7, DQ6, DQ2, or RY/BY# in the erasing bank.

Refer to the Write Operation Status section for information on these status bits.

Once the sector erase operation has begun, only the Erase Suspend command is valid. All other commands are ignored. However, note that a **hardware reset** immediately terminates the erase operation. If that occurs, the sector erase command sequence should be reinitiated once that bank has returned to reading array data, to ensure data integrity.

Figure 4 illustrates the algorithm for the erase operation. Refer to the Erase and Program Operations tables in the AC Characteristics section for parameters, and Figure 19 section for timing diagrams.

### Erase Suspend/Erase Resume Commands

The Erase Suspend command, B0h, allows the system to interrupt a sector erase operation and then read data from, or program data to, any sector not selected for erasure. The bank address is required when writing this command. This command is valid only during the sector erase operation, including the 50  $\mu$ s time-out period during the sector erase command sequence. The Erase Suspend command is ignored if written during the chip erase operation or Embedded Program algorithm.

When the Erase Suspend command is written during the sector erase operation, the device requires a maximum of 20  $\mu$ s to suspend the erase operation. However, when the Erase Suspend command is written during the sector erase time-out, the device immediately terminates the time-out period and suspends the erase operation.

After the erase operation has been suspended, the bank enters the erase-suspend-read mode. The system can read data from or program data to any sector not selected for erasure. (The device “erase suspends” all sectors selected for erasure.) Reading at any address within erase-suspended sectors produces status information on DQ7–DQ0. The system can use DQ7, or DQ6 and DQ2 together, to determine if a sector is actively erasing or is erase-suspended. Refer to the Write Operation Status section for information on these status bits.

After an erase-suspended program operation is complete, the bank returns to the erase-suspend-read mode. The system can determine the status of the

program operation using the DQ7 or DQ6 status bits, just as in the standard Byte Program operation. Refer to the Write Operation Status section for more information.

In the erase-suspend-read mode, the system can also issue the autoselect command sequence. Refer to the Autoselect Mode and Autoselect Command Sequence sections for details.

To resume the sector erase operation, the system must write the Erase Resume command. The bank address of the erase-suspended bank is required when writing this command. Further writes of the Resume command are ignored. Another Erase Suspend command can be written after the chip has resumed erasing.

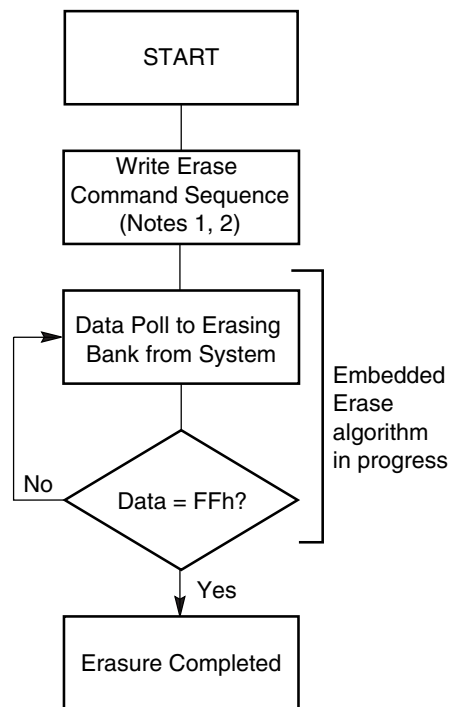

**Notes:**

1. See Table 14 for erase command sequence.
2. See the section on DQ3 for information on the sector erase timer.

**Figure 4. Erase Operation**

## Command Definitions

**Table 14. Am29DL16xD Command Definitions**

Command Sequence (Note 1)			Cycles	Bus Cycles (Notes 2–5)												
				First		Second		Third		Fourth		Fifth		Sixth		
				Addr	Data	Addr	Data	Addr	Data	Addr	Data	Addr	Data	Addr	Data	
Read (Note 6)			1	RA	RD											
Reset (Note 7)			1	XXX	F0											
Autoselect (Note 8)	Manufacturer ID	Word	4	555	AA	2AA	55	(BA)555	90	(BA)X00	01					
		Byte	4	AAA	AA	555	55	(BA)AAA	90	(BA)X01	(see Table 7)					
	Device ID	Word	4	555	AA	2AA	55	(BA)555	90	(BA)X01	(see Table 7)					
		Byte	4	AAA	AA	555	55	(BA)AAA	90	(BA)X02	(see Table 7)					
	SecSi™ Factory Protect (Note 9)	Word	4	555	AA	2AA	55	(BA)555	90	(BA)X03	81/01					
		Byte	4	AAA	AA	555	55	(BA)AAA	90	(BA)X06	81/01					
	Sector Protect Verify (Note 10)	Word	4	555	AA	2AA	55	(BA)555	90	(SA)X02	00/01					
		Byte	4	AAA	AA	555	55	(BA)AAA	90	(SA)X04	00/01					
Enter SecSi Sector Region		Word	3	555	AA	2AA	55	555	88							
		Byte	3	AAA	AA	555	55	AAA	88							
Exit SecSi Sector Region		Word	4	555	AA	2AA	55	555	90	XXX	00					
		Byte	4	AAA	AA	555	55	AAA	90	XXX	00					
Program		Word	4	555	AA	2AA	55	555	A0	PA	PD					
		Byte	4	AAA	AA	555	55	AAA	A0	PA	PD					
Unlock Bypass		Word	3	555	AA	2AA	55	555	20							
		Byte	3	AAA	AA	555	55	AAA	20							
Unlock Bypass Program (Note 11)			2	XXX	A0	PA	PD									
Unlock Bypass Reset (Note 12)			2	XXX	90	XXX	00									
Chip Erase		Word	6	555	AA	2AA	55	555	80	555	AA	2AA	55	555	10	
		Byte	6	AAA	AA	555	55	AAA	80	AAA	AA	555	55	AAA	10	
Sector Erase		Word	6	555	AA	2AA	55	555	80	555	AA	2AA	55	SA	30	
		Byte	6	AAA	AA	555	55	AAA	80	AAA	AA	555	55	SA	30	
Erase Suspend (Note 13)			1	BA	B0											
Erase Resume (Note 14)			1	BA	30											
CFI Query (Note 15)		Word	1	55	98											
		Byte	1	AA	98											

**Legend:**

X = Don't care

RA = Address of the memory location to be read.

RD = Data read from location RA during read operation.

PA = Address of the memory location to be programmed. Addresses latch on the falling edge of the WE# or CE# pulse, whichever happens later.

PD = Data to be programmed at location PA. Data latches on the rising edge of WE# or CE# pulse, whichever happens first.

SA = Address of the sector to be verified (in autoselect mode) or erased. Address bits A19–A12 uniquely select any sector.

BA = Address of the bank that is being switched to autoselect mode, is in bypass mode, or is being erased.

**Notes:**

- See Table 1 for description of bus operations.
- All values are in hexadecimal.
- Except for the read cycle and the fourth cycle of the autoselect command sequence, all bus cycles are write cycles.
- Data bits DQ15–DQ8 are don't care in command sequences, except for RD and PD.
- Unless otherwise noted, address bits A19–A11 are don't cares.
- No unlock or command cycles required when bank is reading array data.
- The Reset command is required to return to reading array data (or to the erase-suspend-read mode if previously in Erase Suspend) when a bank is in the autoselect mode, or if DQ5 goes high (while the bank is providing status information).
- The fourth cycle of the autoselect command sequence is a read cycle. The system must provide the bank address to obtain the manufacturer ID, device ID, or SecSi Sector factory protect information. Data bits DQ15–DQ8 are don't care. See the Autoselect Command Sequence section for more information.
- The data is 81h for factory locked and 01h for not factory locked.
- The data is 00h for an unprotected sector/sector block and 01h for a protected sector/sector block.
- The Unlock Bypass command is required prior to the Unlock Bypass Program command.
- The Unlock Bypass Reset command is required to return to reading array data when the bank is in the unlock bypass mode.
- The system may read and program in non-erasing sectors, or enter the autoselect mode, when in the Erase Suspend mode. The Erase Suspend command is valid only during a sector erase operation, and requires the bank address.
- The Erase Resume command is valid only during the Erase



## WRITE OPERATION STATUS

The device provides several bits to determine the status of a program or erase operation: DQ2, DQ3, DQ5, DQ6, and DQ7. Table 15 and the following subsections describe the function of these bits. DQ7 and DQ6 each offer a method for determining whether a program or erase operation is complete or in progress. The device also provides a hardware-based output signal, RY/BY#, to determine whether an Embedded Program or Erase operation is in progress or has been completed.

### DQ7: Data# Polling

The Data# Polling bit, DQ7, indicates to the host system whether an Embedded Program or Erase algorithm is in progress or completed, or whether a bank is in Erase Suspend. Data# Polling is valid after the rising edge of the final WE# pulse in the command sequence.

During the Embedded Program algorithm, the device outputs on DQ7 the complement of the datum programmed to DQ7. This DQ7 status also applies to programming during Erase Suspend. When the Embedded Program algorithm is complete, the device outputs the datum programmed to DQ7. The system must provide the program address to read valid status information on DQ7. If a program address falls within a protected sector, Data# Polling on DQ7 is active for approximately 1  $\mu$ s, then that bank returns to reading array data.

During the Embedded Erase algorithm, Data# Polling produces a “0” on DQ7. When the Embedded Erase algorithm is complete, or if the bank enters the Erase Suspend mode, Data# Polling produces a “1” on DQ7. The system must provide an address within any of the sectors selected for erasure to read valid status information on DQ7.

After an erase command sequence is written, if all sectors selected for erasing are protected, Data# Polling on DQ7 is active for approximately 100  $\mu$ s, then the bank returns to reading array data. If not all selected sectors are protected, the Embedded Erase algorithm erases the unprotected sectors, and ignores the selected sectors that are protected. However, if the system reads DQ7 at an address within a protected sector, the status may not be valid.

Just prior to the completion of an Embedded Program or Erase operation, DQ7 may change asynchronously with DQ0–DQ6 while Output Enable (OE#) is asserted low. That is, the device may change from providing status information to valid data on DQ7. Depending on when the system samples the DQ7 output, it may read the status or valid data. Even if the device has com-

pleted the program or erase operation and DQ7 has valid data, the data outputs on DQ0–DQ6 may be still invalid. Valid data on DQ0–DQ7 will appear on successive read cycles.

Table 15 shows the outputs for Data# Polling on DQ7. Figure 5 shows the Data# Polling algorithm. Figure 21 in the AC Characteristics section shows the Data# Polling timing diagram.

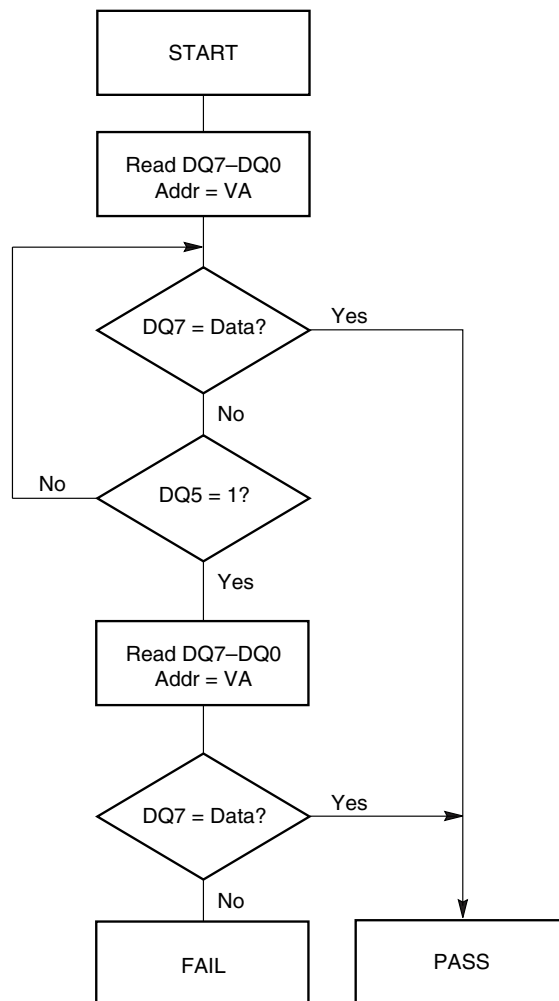

**Notes:**

1. VA = Valid address for programming. During a sector erase operation, a valid address is any sector address within the sector being erased. During chip erase, a valid address is any non-protected sector address.
2. DQ7 should be rechecked even if DQ5 = “1” because DQ7 may change simultaneously with DQ5.

**Figure 5. Data# Polling Algorithm**

## R<sub>Y</sub>/B<sub>Y</sub>#: Ready/Busy#

The R<sub>Y</sub>/B<sub>Y</sub># is a dedicated, open-drain output pin which indicates whether an Embedded Algorithm is in progress or complete. The R<sub>Y</sub>/B<sub>Y</sub># status is valid after the rising edge of the final WE# pulse in the command sequence. Since R<sub>Y</sub>/B<sub>Y</sub># is an open-drain output, several R<sub>Y</sub>/B<sub>Y</sub># pins can be tied together in parallel with a pull-up resistor to V<sub>CC</sub>.

If the output is low (Busy), the device is actively erasing or programming. (This includes programming in the Erase Suspend mode.) If the output is high (Ready), the device is reading array data, the standby mode, or one of the banks is in the erase-suspend-read mode.

Table 15 shows the outputs for R<sub>Y</sub>/B<sub>Y</sub>#.

## DQ6: Toggle Bit I

Toggle Bit I on DQ6 indicates whether an Embedded Program or Erase algorithm is in progress or complete, or whether the device has entered the Erase Suspend mode. Toggle Bit I may be read at any address, and is valid after the rising edge of the final WE# pulse in the command sequence (prior to the program or erase operation), and during the sector erase time-out.

During an Embedded Program or Erase algorithm operation, successive read cycles to any address cause DQ6 to toggle. The system may use either OE# or CE# to control the read cycles. When the operation is complete, DQ6 stops toggling.

After an erase command sequence is written, if all sectors selected for erasing are protected, DQ6 toggles for approximately 100 μs, then returns to reading array data. If not all selected sectors are protected, the Embedded Erase algorithm erases the unprotected sectors, and ignores the selected sectors that are protected.

The system can use DQ6 and DQ2 together to determine whether a sector is actively erasing or is erase-suspended. When the device is actively erasing (that is, the Embedded Erase algorithm is in progress), DQ6 toggles. When the device enters the Erase Suspend mode, DQ6 stops toggling. However, the system must also use DQ2 to determine which sectors are erasing or erase-suspended. Alternatively, the system can use DQ7 (see the subsection on DQ7: Data# Polling).

If a program address falls within a protected sector, DQ6 toggles for approximately 1 μs after the program command sequence is written, then returns to reading array data.

DQ6 also toggles during the erase-suspend-program mode, and stops toggling once the Embedded Program algorithm is complete.

Table 15 shows the outputs for Toggle Bit I on DQ6. Figure 6 shows the toggle bit algorithm. Figure 22 in the “AC Characteristics” section shows the toggle bit timing diagrams. Figure 23 shows the differences between DQ2 and DQ6 in graphical form. See also the subsection on DQ2: Toggle Bit II.

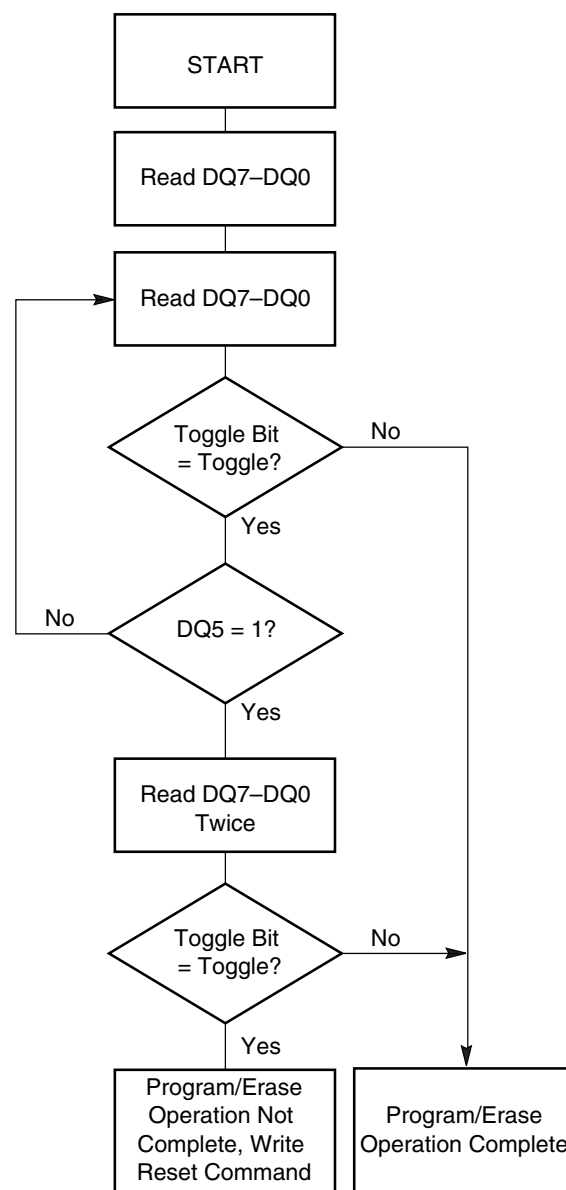

**Note:** The system should recheck the toggle bit even if DQ5 = “1” because the toggle bit may stop toggling as DQ5 changes to “1.” See the subsections on DQ6 and DQ2 for more information.

Figure 6. Toggle Bit Algorithm

## DQ2: Toggle Bit II

The “Toggle Bit II” on DQ2, when used with DQ6, indicates whether a particular sector is actively erasing (that is, the Embedded Erase algorithm is in progress), or whether that sector is erase-suspended. Toggle Bit II is valid after the rising edge of the final WE# pulse in the command sequence.

DQ2 toggles when the system reads at addresses within those sectors that have been selected for erasure. (The system may use either OE# or CE# to control the read cycles.) But DQ2 cannot distinguish whether the sector is actively erasing or is erase-suspended. DQ6, by comparison, indicates whether the device is actively erasing, or is in Erase Suspend, but cannot distinguish which sectors are selected for erasure. Thus, both status bits are required for sector and mode information. Refer to Table 15 to compare outputs for DQ2 and DQ6.

Figure 6 shows the toggle bit algorithm in flowchart form, and the section “DQ2: Toggle Bit II” explains the algorithm. See also the DQ6: Toggle Bit I subsection. Figure 22 shows the toggle bit timing diagram. Figure 23 shows the differences between DQ2 and DQ6 in graphical form.

## Reading Toggle Bits DQ6/DQ2

Refer to Figure 6 for the following discussion. Whenever the system initially begins reading toggle bit status, it must read DQ7–DQ0 at least twice in a row to determine whether a toggle bit is toggling. Typically, the system would note and store the value of the toggle bit after the first read. After the second read, the system would compare the new value of the toggle bit with the first. If the toggle bit is not toggling, the device has completed the program or erase operation. The system can read array data on DQ7–DQ0 on the following read cycle.

However, if after the initial two read cycles, the system determines that the toggle bit is still toggling, the system also should note whether the value of DQ5 is high (see the section on DQ5). If it is, the system should then determine again whether the toggle bit is toggling, since the toggle bit may have stopped toggling just as DQ5 went high. If the toggle bit is no longer toggling, the device has successfully completed the program or erase operation. If it is still toggling, the device did not complete the operation successfully, and the system must write the reset command to return to reading array data.

The remaining scenario is that the system initially determines that the toggle bit is toggling and DQ5 has not gone high. The system may continue to monitor the toggle bit and DQ5 through successive read cy-

cles, determining the status as described in the previous paragraph. Alternatively, it may choose to perform other system tasks. In this case, the system must start at the beginning of the algorithm when it returns to determine the status of the operation (top of Figure 6).

## DQ5: Exceeded Timing Limits

DQ5 indicates whether the program or erase time has exceeded a specified internal pulse count limit. Under these conditions DQ5 produces a “1,” indicating that the program or erase cycle was not successfully completed.

The device may output a “1” on DQ5 if the system tries to program a “1” to a location that was previously programmed to “0.” **Only an erase operation can change a “0” back to a “1.”** Under this condition, the device halts the operation, and when the timing limit has been exceeded, DQ5 produces a “1.”

Under both these conditions, the system must write the reset command to return to reading array data (or to the erase-suspend-read mode if a bank was previously in the erase-suspend-program mode).

## DQ3: Sector Erase Timer

After writing a sector erase command sequence, the system may read DQ3 to determine whether or not erasure has begun. (The sector erase timer does not apply to the chip erase command.) If additional sectors are selected for erasure, the entire time-out also applies after each additional sector erase command. When the time-out period is complete, DQ3 switches from a “0” to a “1.” If the time between additional sector erase commands from the system can be assumed to be less than 50  $\mu$ s, the system need not monitor DQ3. See also the Sector Erase Command Sequence section.

After the sector erase command is written, the system should read the status of DQ7 (Data# Polling) or DQ6 (Toggle Bit I) to ensure that the device has accepted the command sequence, and then read DQ3. If DQ3 is “1,” the Embedded Erase algorithm has begun; all further commands (except Erase Suspend) are ignored until the erase operation is complete. If DQ3 is “0,” the device will accept additional sector erase commands. To ensure the command has been accepted, the system software should check the status of DQ3 prior to and following each subsequent sector erase command. If DQ3 is high on the second status check, the last command might not have been accepted.

Table 15 shows the status of DQ3 relative to the other status bits.



Table 15. Write Operation Status

Status		DQ7 (Note 2)	DQ6	DQ5 (Note 1)	DQ3	DQ2 (Note 2)	RY/BY#	
Standard Mode	Embedded Program Algorithm	DQ7#	Toggle	0	N/A	No toggle	0	
	Embedded Erase Algorithm	0	Toggle	0	1	Toggle	0	
Erase Suspend Mode	Erase-Suspend-Read	Erase Suspended Sector	1	No toggle	0	N/A	Toggle	1
		Non-Erase Suspended Sector	Data	Data	Data	Data	Data	1
	Erase-Suspend-Program	DQ7#	Toggle	0	N/A	N/A	0	

**Notes:**

1. DQ5 switches to '1' when an Embedded Program or Embedded Erase operation has exceeded the maximum timing limits. Refer to the section on DQ5 for more information.
2. DQ7 and DQ2 require a valid address when reading status information. Refer to the appropriate subsection for further details.
3. When reading write operation status bits, the system must always provide the bank address where the Embedded Algorithm is in progress. The device outputs array data if the system addresses a non-busy bank.

## ABSOLUTE MAXIMUM RATINGS

Storage Temperature

Plastic Packages . . . . . -65°C to +150°C

Ambient Temperature

with Power Applied. . . . . -65°C to +125°C

Voltage with Respect to Ground

$V_{CC}$  (Note 1) . . . . . -0.5 V to +4.0 V

A9, OE#, and RESET#  
(Note 2). . . . . -0.5 V to +12.5 V

WP#/ACC . . . . . -0.5 V to +10.5 V

All other pins (Note 1) . . . . . -0.5 V to  $V_{CC}$  +0.5 V

Output Short Circuit Current (Note 3) . . . . . 200 mA

**Notes:**

1. Minimum DC voltage on input or I/O pins is -0.5 V. During voltage transitions, input or I/O pins may overshoot  $V_{SS}$  to -2.0 V for periods of up to 20 ns. Maximum DC voltage on input or I/O pins is  $V_{CC}$  +0.5 V. See Figure 7. During voltage transitions, input or I/O pins may overshoot to  $V_{CC}$  +2.0 V for periods up to 20 ns. See Figure 8.
2. Minimum DC input voltage on pins A9, OE#, RESET#, and WP#/ACC is -0.5 V. During voltage transitions, A9, OE#, WP#/ACC, and RESET# may overshoot  $V_{SS}$  to -2.0 V for periods of up to 20 ns. See Figure 7. Maximum DC input voltage on pin A9 is +12.5 V which may overshoot to +14.0 V for periods up to 20 ns. Maximum DC input voltage on WP#/ACC is +9.5 V which may overshoot to +12.0 V for periods up to 20 ns.
3. No more than one output may be shorted to ground at a time. Duration of the short circuit should not be greater than one second.

Stresses above those listed under “Absolute Maximum Ratings” may cause permanent damage to the device. This is a stress rating only; functional operation of the device at these or any other conditions above those indicated in the operational sections of this data sheet is not implied. Exposure of the device to absolute maximum rating conditions for extended periods may affect device reliability.

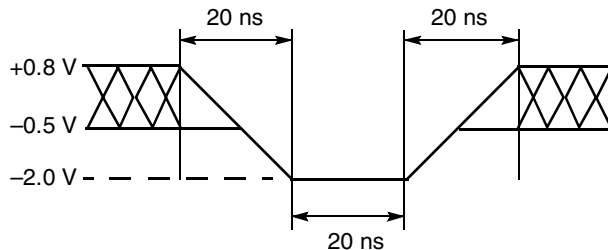

**Figure 7. Maximum Negative Overshoot Waveform**

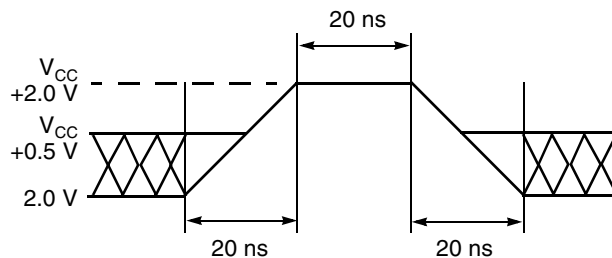

**Figure 8. Maximum Positive Overshoot Waveform**

## OPERATING RANGES

**Industrial (I) Devices**

Ambient Temperature ( $T_A$ ) . . . . . -40°C to +85°C

**$V_{CC}$  Supply Voltages**

$V_{CC}$  for standard voltage range . . . . . 2.7 V to 3.6 V

Operating ranges define those limits between which the functionality of the device is guaranteed.

## DC CHARACTERISTICS

### CMOS Compatible

Parameter Symbol	Parameter Description	Test Conditions	Min	Typ	Max	Unit
$I_{LI}$	Input Load Current	$V_{IN} = V_{SS}$ to $V_{CC}$ , $V_{CC} = V_{CC\ max}$			$\pm 1.0$	$\mu A$
$I_{LIT}$	A9 Input Load Current	$V_{CC} = V_{CC\ max}$ ; A9 = 12.5 V			35	$\mu A$
$I_{LO}$	Output Leakage Current	$V_{OUT} = V_{SS}$ to $V_{CC}$ , $V_{CC} = V_{CC\ max}$			$\pm 1.0$	$\mu A$
$I_{CC1}$	$V_{CC}$ Active Read Current (Notes 1, 2)	CE# = $V_{IL}$ , OE# = $V_{IH}$ , Byte Mode	5 MHz	10	16	mA
			1 MHz	2	4	
		CE# = $V_{IL}$ , OE# = $V_{IH}$ , Word Mode	5 MHz	10	16	
			1 MHz	2	4	
$I_{CC2}$	$V_{CC}$ Active Write Current (Notes 2, 3)	CE# = $V_{IL}$ , OE# = $V_{IH}$ , WE# = $V_{IL}$		15	30	mA
$I_{CC3}$	$V_{CC}$ Standby Current (Note 2)	CE#, RESET# = $V_{CC} \pm 0.3$ V		0.2	5	$\mu A$
$I_{CC4}$	$V_{CC}$ Reset Current (Note 2)	RESET# = $V_{SS} \pm 0.3$ V		0.2	5	$\mu A$
$I_{CC5}$	Automatic Sleep Mode (Notes 2, 4)	$V_{IH} = V_{CC} \pm 0.3$ V; $V_{IL} = V_{SS} \pm 0.3$ V		0.2	5	$\mu A$
$I_{CC6}$	$V_{CC}$ Active Read-While-Program Current (Notes 1, 2)	CE# = $V_{IL}$ , OE# = $V_{IH}$	Byte	21	45	mA
			Word	21	45	
$I_{CC7}$	$V_{CC}$ Active Read-While-Erase Current (Notes 1, 2)	CE# = $V_{IL}$ , OE# = $V_{IH}$	Byte	21	45	mA
			Word	21	45	
$I_{CC8}$	$V_{CC}$ Active Program-While-Erase-Suspended Current (Notes 2, 5)	CE# = $V_{IL}$ , OE# = $V_{IH}$		17	35	mA
$I_{ACC}$	ACC Accelerated Program Current, Word or Byte	CE# = $V_{IL}$ , OE# = $V_{IH}$	ACC pin	5	10	mA
			$V_{CC}$ pin	15	30	mA
$V_{IL}$	Input Low Voltage		-0.5		0.8	V
$V_{IH}$	Input High Voltage		$0.7 \times V_{CC}$		$V_{CC} + 0.3$	V
$V_{HH}$	Voltage for WP#/ACC Sector Protect/Unprotect and Program Acceleration	$V_{CC} = 3.0$ V $\pm$ 10%	8.5		9.5	V
$V_{ID}$	Voltage for Autoselect and Temporary Sector Unprotect	$V_{CC} = 3.0$ V $\pm$ 10%	8.5		12.5	V
$V_{OL}$	Output Low Voltage	$I_{OL} = 4.0$ mA, $V_{CC} = V_{CC\ min}$			0.45	V
$V_{OH1}$	Output High Voltage	$I_{OH} = -2.0$ mA, $V_{CC} = V_{CC\ min}$	$0.85 V_{CC}$			V
$V_{OH2}$		$I_{OH} = -100$ $\mu A$ , $V_{CC} = V_{CC\ min}$	$V_{CC} - 0.4$			
$V_{LKO}$	Low $V_{CC}$ Lock-Out Voltage (Note 5)		2.3		2.5	V

#### Notes:

1. The  $I_{CC}$  current listed is typically less than 2 mA/MHz, with OE# at  $V_{IH}$ .
2. Maximum  $I_{CC}$  specifications are tested with  $V_{CC} = V_{CC\ max}$ .
3.  $I_{CC}$  active while Embedded Erase or Embedded Program is in progress.
4. Automatic sleep mode enables the low power mode when addresses remain stable for  $t_{ACC} + 30$  ns. Typical sleep mode current is 200 nA.
5. Not 100% tested.

DC CHARACTERISTICS

Zero-Power Flash

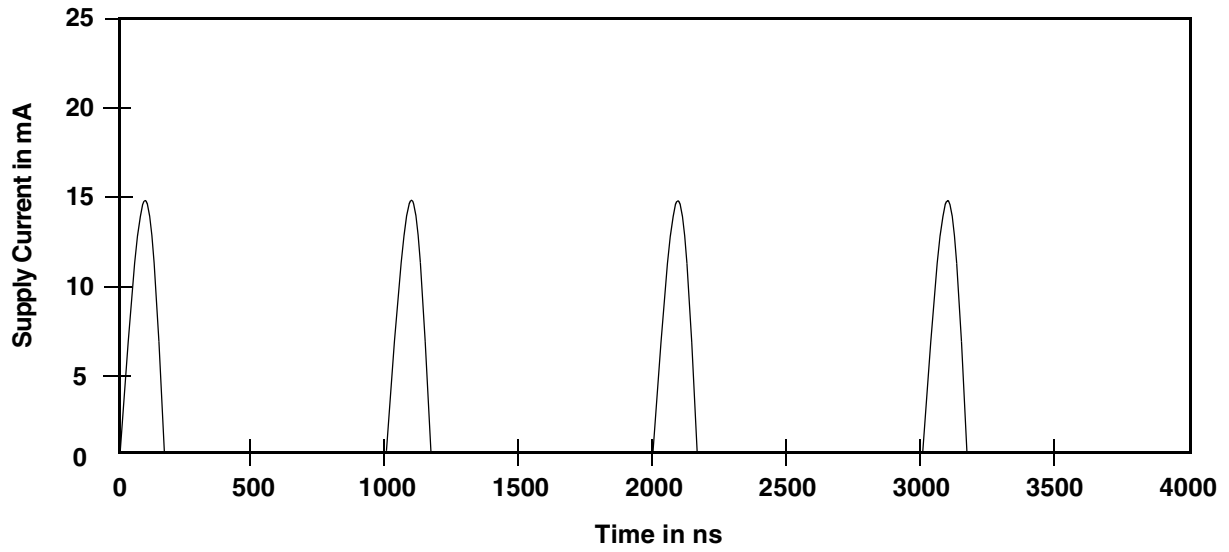

Note: Addresses are switching at 1 MHz

Figure 9.  $I_{CC1}$  Current vs. Time (Showing Active and Automatic Sleep Currents)

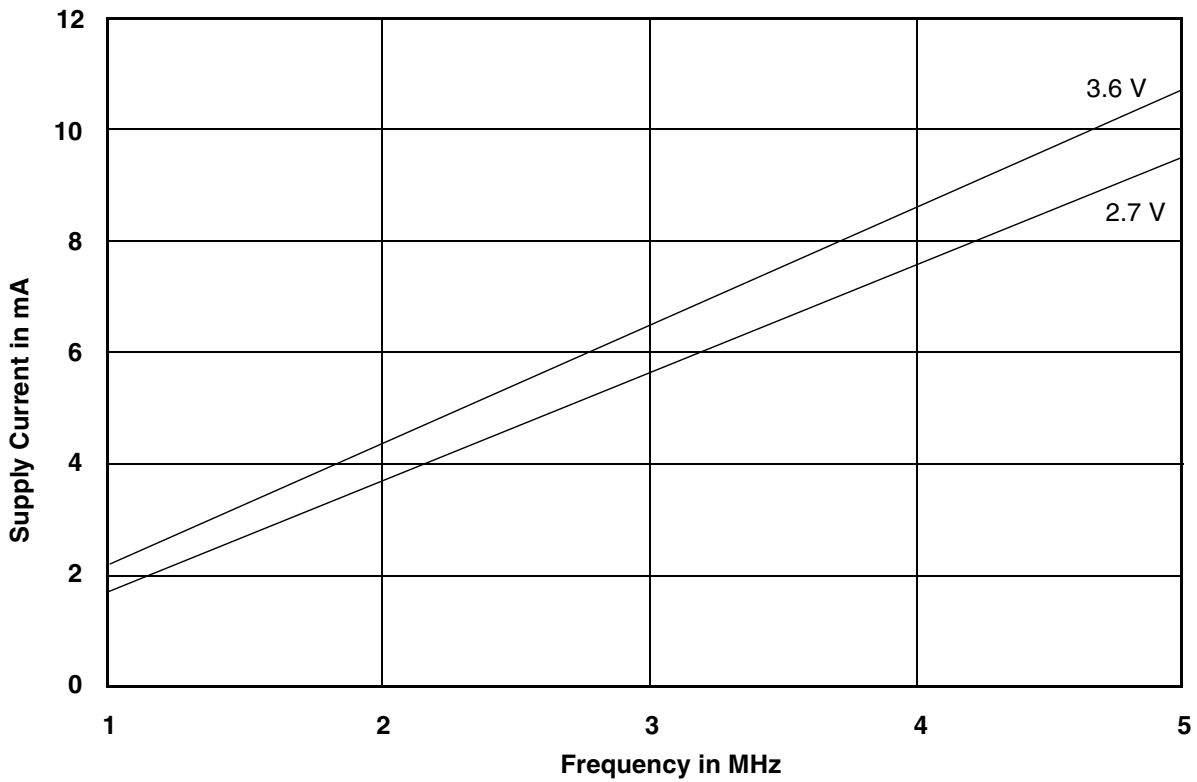

Note:  $T = 25^{\circ}C$

Figure 10. Typical  $I_{CC1}$  vs. Frequency

## TEST CONDITIONS

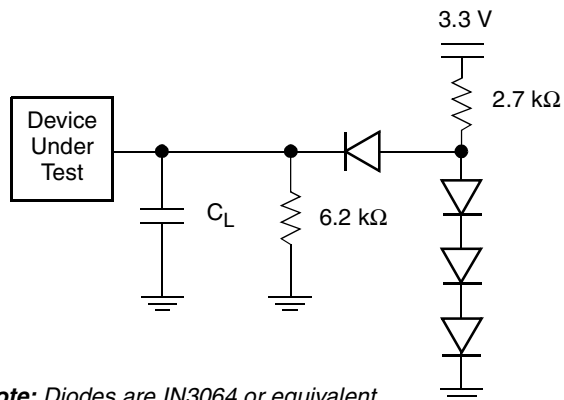

Note: Diodes are IN3064 or equivalent

Figure 11. Test Setup

Table 16. Test Specifications

Test Condition	70, 80	90, 120	Unit
Output Load	1 TTL gate		
Output Load Capacitance, $C_L$ (including jig capacitance)	30	100	pF
Input Rise and Fall Times	5		ns
Input Pulse Levels	0.0–3.0		V
Input timing measurement reference levels	1.5		V
Output timing measurement reference levels	1.5		V

## Key To Switching Waveforms

WAVEFORM	INPUTS	OUTPUTS
		Steady
		Changing from H to L
		Changing from L to H
	Don't Care, Any Change Permitted	Changing, State Unknown
	Does Not Apply	Center Line is High Impedance State (High Z)

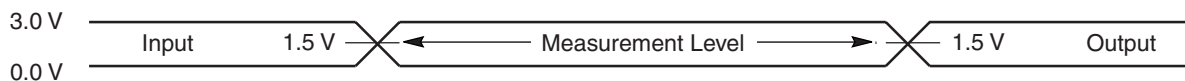

Figure 12. Input Waveforms and Measurement Levels

## AC CHARACTERISTICS

### Read-Only Operations

Parameter		Description	Test Setup		Speed Options				Unit
JEDEC	Std				70	80	90	120	
$t_{AVAV}$	$t_{RC}$	Read Cycle Time (Note 1)		Min	70	80	90	120	ns
$t_{AVQV}$	$t_{ACC}$	Address to Output Delay	CE#, OE# = $V_{IL}$	Max	70	80	90	120	ns
$t_{ELQV}$	$t_{CE}$	Chip Enable to Output Delay	OE# = $V_{IL}$	Max	70	80	90	120	ns
$t_{GLQV}$	$t_{OE}$	Output Enable to Output Delay		Max	30	30	40	50	ns
$t_{EHQZ}$	$t_{DF}$	Chip Enable to Output High Z (Notes 1, 3)		Max	16	16	16	16	ns
$t_{GHQZ}$	$t_{DF}$	Output Enable to Output High Z (Notes 1, 3)		Max	16	16	16	16	ns
$t_{AXQX}$	$t_{OH}$	Output Hold Time From Addresses, CE# or OE#, Whichever Occurs First		Min	0				ns
	$t_{OEh}$	Output Enable Hold Time (Note 1)	Read	Min	0				ns
			Toggle and Data# Polling	Min	10				ns

**Notes:**

1. Not 100% tested.
2. See Figure 11 and Table 16 for test specifications.
3. Measurements performed by placing a 50-ohm termination on the data pin with a bias of  $V_{CC}/2$ . The time from OE# high to the data bus driven to  $V_{CC}/2$  is taken as  $t_{DF}$

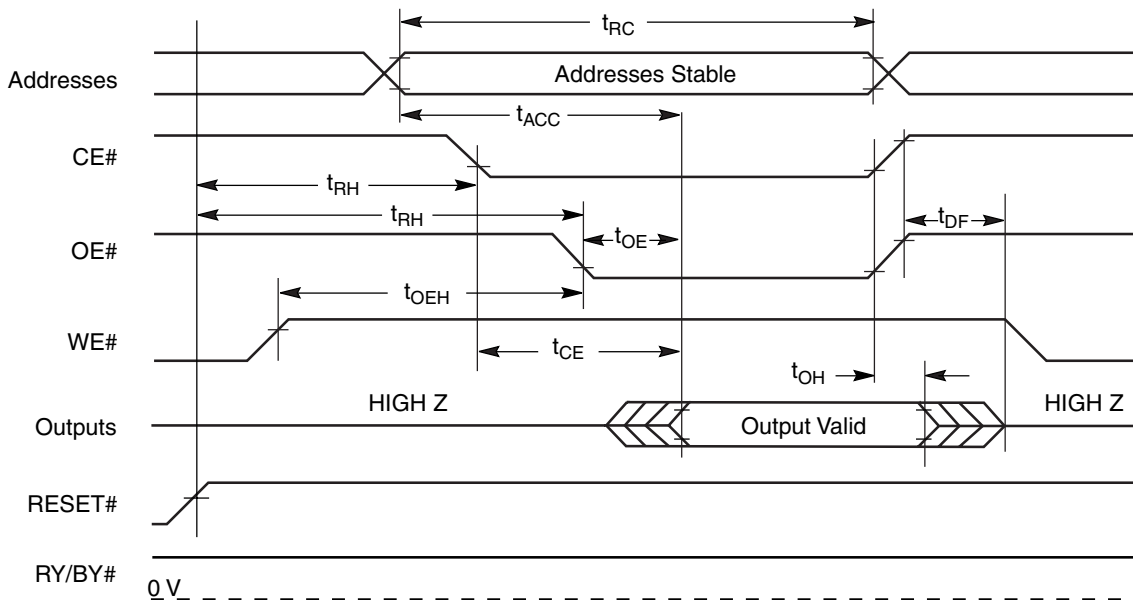

Figure 13. Read Operation Timings

## AC CHARACTERISTICS

### Hardware Reset (RESET#)

Parameter		Description		All Speed Options	Unit
JEDEC	Std				
	$t_{Ready}$	RESET# Pin Low (During Embedded Algorithms) to Read Mode (See Note)	Max	20	$\mu s$
	$t_{Ready}$	RESET# Pin Low (NOT During Embedded Algorithms) to Read Mode (See Note)	Max	500	ns
	$t_{RP}$	RESET# Pulse Width	Min	500	ns
	$t_{RH}$	Reset High Time Before Read (See Note)	Min	50	ns
	$t_{RPD}$	RESET# Low to Standby Mode	Min	20	$\mu s$
	$t_{RB}$	RY/BY# Recovery Time	Min	0	ns

**Note:** Not 100% tested.

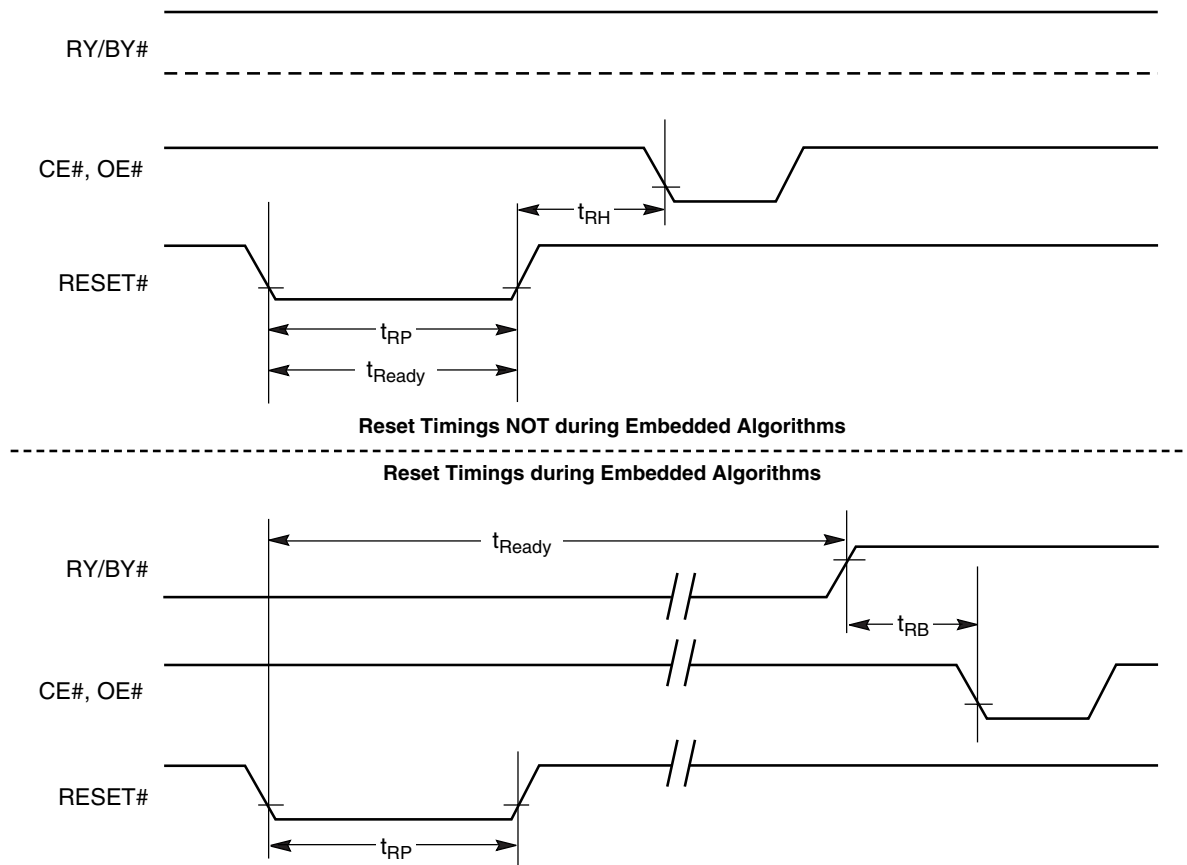

Figure 14. Reset Timings

AC CHARACTERISTICS

Word/Byte Configuration (BYTE#)

Parameter		Description		Speed Options				Unit
JEDEC	Std			70	80	90	120	
	$t_{ELFL}/t_{ELFH}$	CE# to BYTE# Switching Low or High	Max	5				ns
	$t_{FLOZ}$	BYTE# Switching Low to Output HIGH Z	Max	25	25	30	30	ns
	$t_{FHQV}$	BYTE# Switching High to Output Active	Min	70	80	90	120	ns

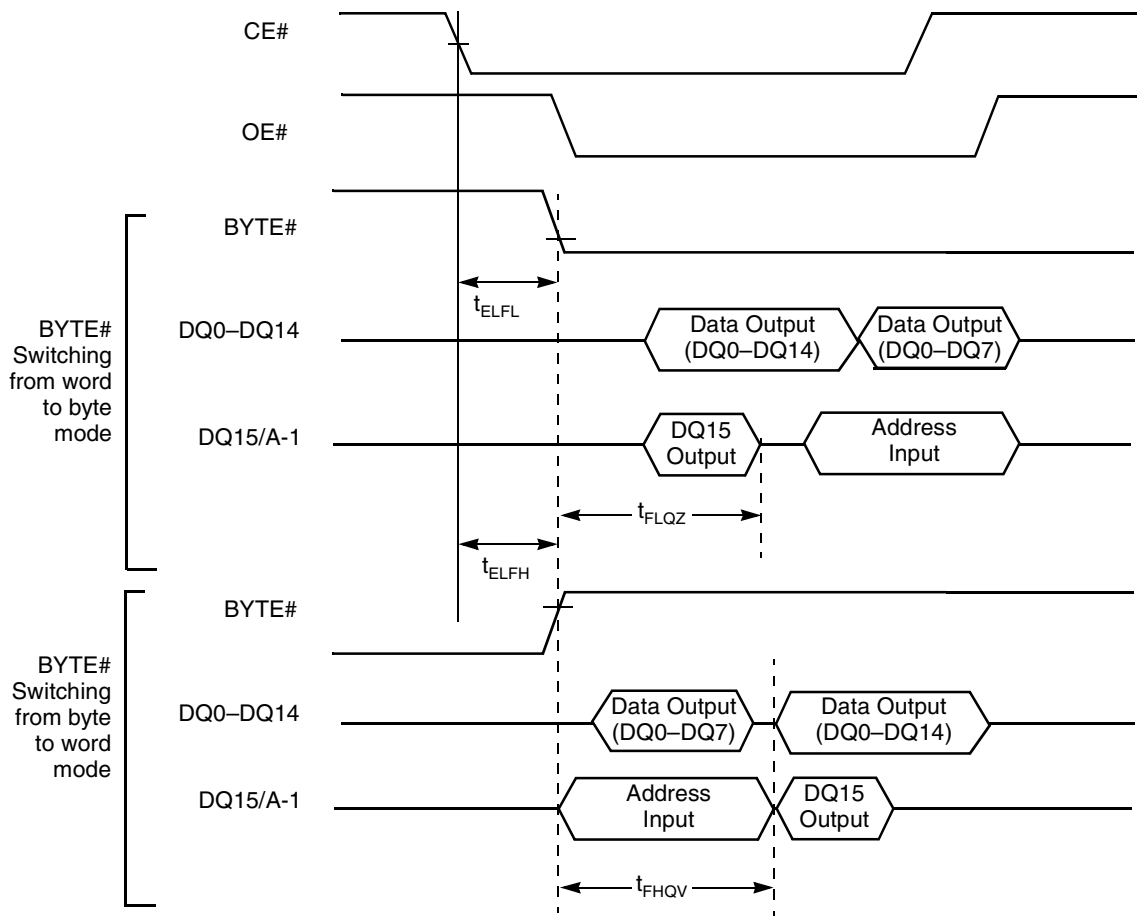
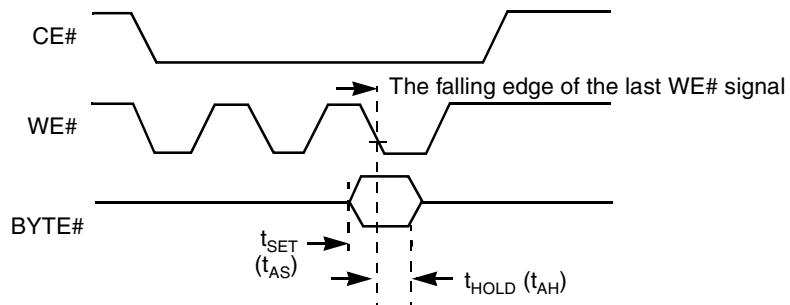

Figure 15. BYTE# Timings for Read Operations



Note: Refer to the Erase/Program Operations table for  $t_{AS}$  and  $t_{AH}$  specifications.

Figure 16. BYTE# Timings for Write Operations



## AC CHARACTERISTICS

### Erase and Program Operations

Parameter		Description		Speed Options				Unit
JEDEC	Std			70	80	90	120	
$t_{AVAV}$	$t_{WC}$	Write Cycle Time (Note 1)	Min	70	80	90	120	ns
$t_{AVWL}$	$t_{AS}$	Address Setup Time	Min	0				ns
	$t_{ASO}$	Address Setup Time to OE# low during toggle bit polling	Min	15	15	15	15	ns
$t_{WLAX}$	$t_{AH}$	Address Hold Time	Min	45	45	45	50	ns
	$t_{AHT}$	Address Hold Time From CE# or OE# high during toggle bit polling	Min	0				ns
$t_{DVWH}$	$t_{DS}$	Data Setup Time	Min	35	35	45	50	ns
$t_{WHDX}$	$t_{DH}$	Data Hold Time	Min	0				ns
	$t_{OEPH}$	Output Enable High during toggle bit polling	Min	20	20	20	20	ns
$t_{GHWL}$	$t_{GHWL}$	Read Recovery Time Before Write (OE# High to WE# Low)	Min	0				ns
$t_{ELWL}$	$t_{CS}$	CE# Setup Time	Min	0				ns
$t_{WHEH}$	$t_{CH}$	CE# Hold Time	Min	0				ns
$t_{WLWH}$	$t_{WP}$	Write Pulse Width	Min	30	30	35	50	ns
$t_{WHDL}$	$t_{WPH}$	Write Pulse Width High	Min	30	30	30	30	ns
	$t_{SR/W}$	Latency Between Read and Write Operations	Min	0				ns
$t_{WHWH1}$	$t_{WHWH1}$	Programming Operation (Note 2)	Byte	Typ				$\mu$ s
			Word	Typ				
$t_{WHWH1}$	$t_{WHWH1}$	Accelerated Programming Operation, Word or Byte (Note 2)	Typ	4				$\mu$ s
$t_{WHWH2}$	$t_{WHWH2}$	Sector Erase Operation (Note 2)	Typ	0.7				sec
	$t_{VCS}$	$V_{CC}$ Setup Time (Note 1)	Min	50				$\mu$ s
	$t_{RB}$	Write Recovery Time from RY/BY#	Min	0				ns
	$t_{BUSY}$	Program/Erase Valid to RY/BY# Delay	Min	90				ns

#### Notes:

1. Not 100% tested.
2. See the "Erase And Programming Performance" section for more information.

AC CHARACTERISTICS

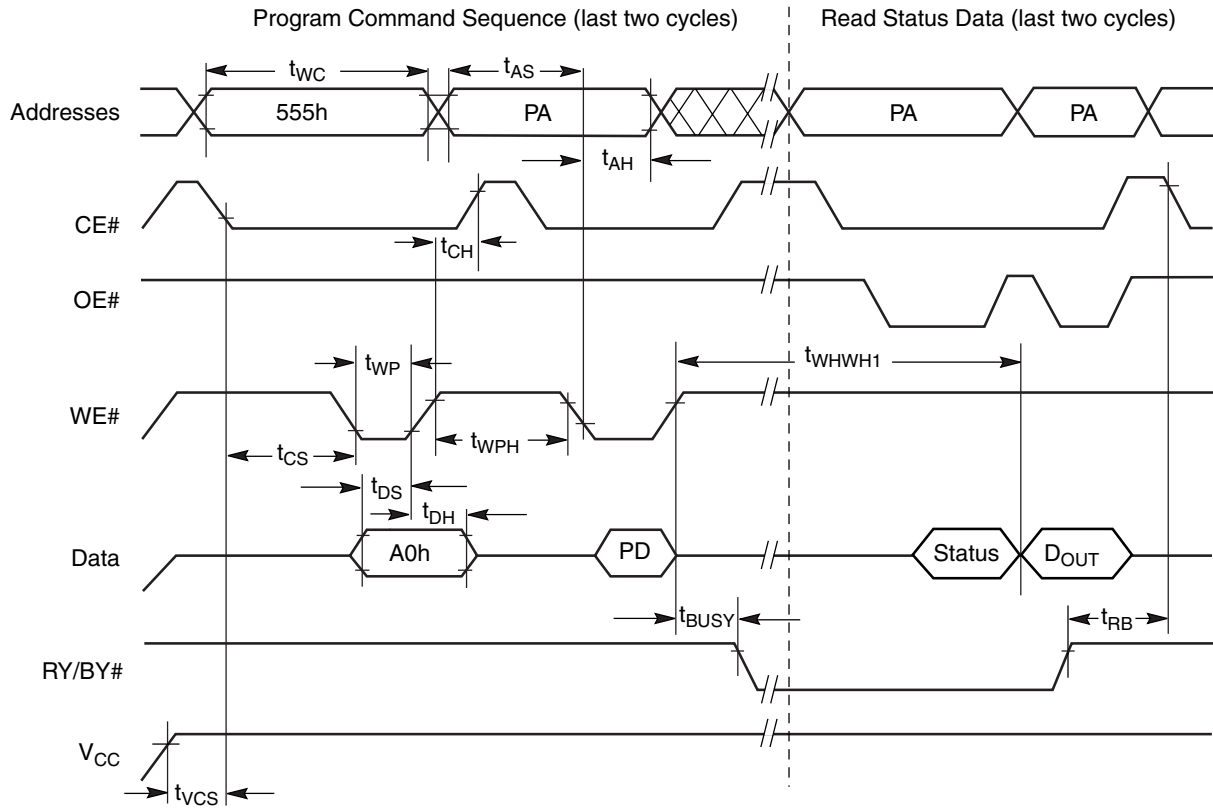

Notes:

1. PA = program address, PD = program data,  $D_{OUT}$  is the true data at the program address.
2. Illustration shows device in word mode.

Figure 17. Program Operation Timings

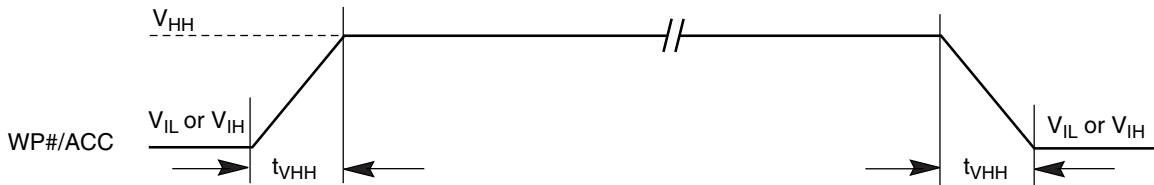
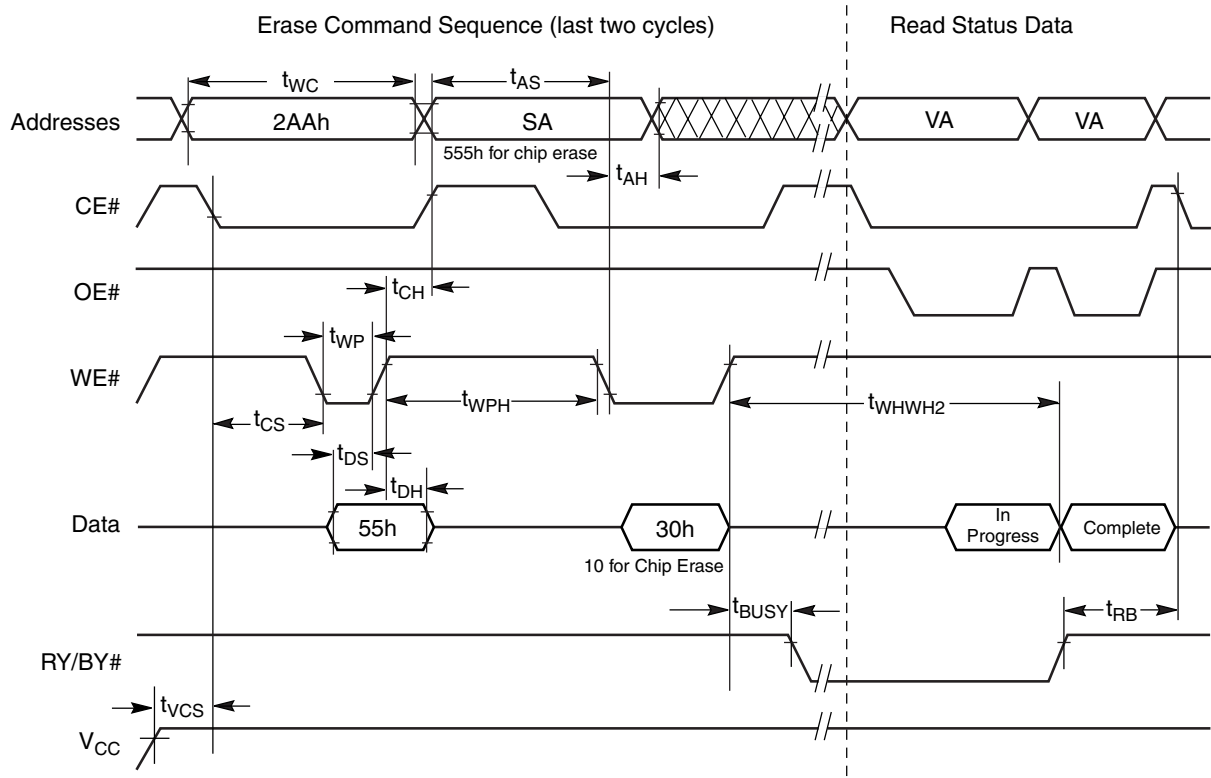

Figure 18. Accelerated Program Timing Diagram

## AC CHARACTERISTICS



**Notes:**

1. SA = sector address (for Sector Erase), VA = Valid Address for reading status data (see "Write Operation Status").
2. These waveforms are for the word mode.

**Figure 19. Chip/Sector Erase Operation Timings**

AC CHARACTERISTICS

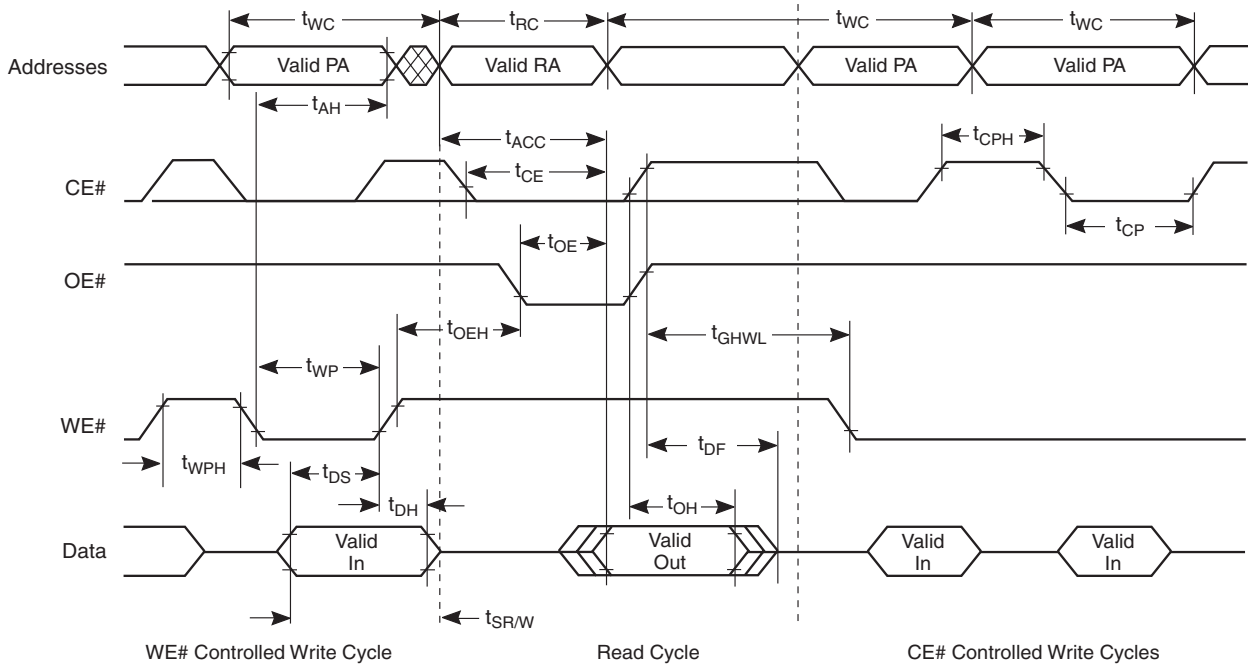
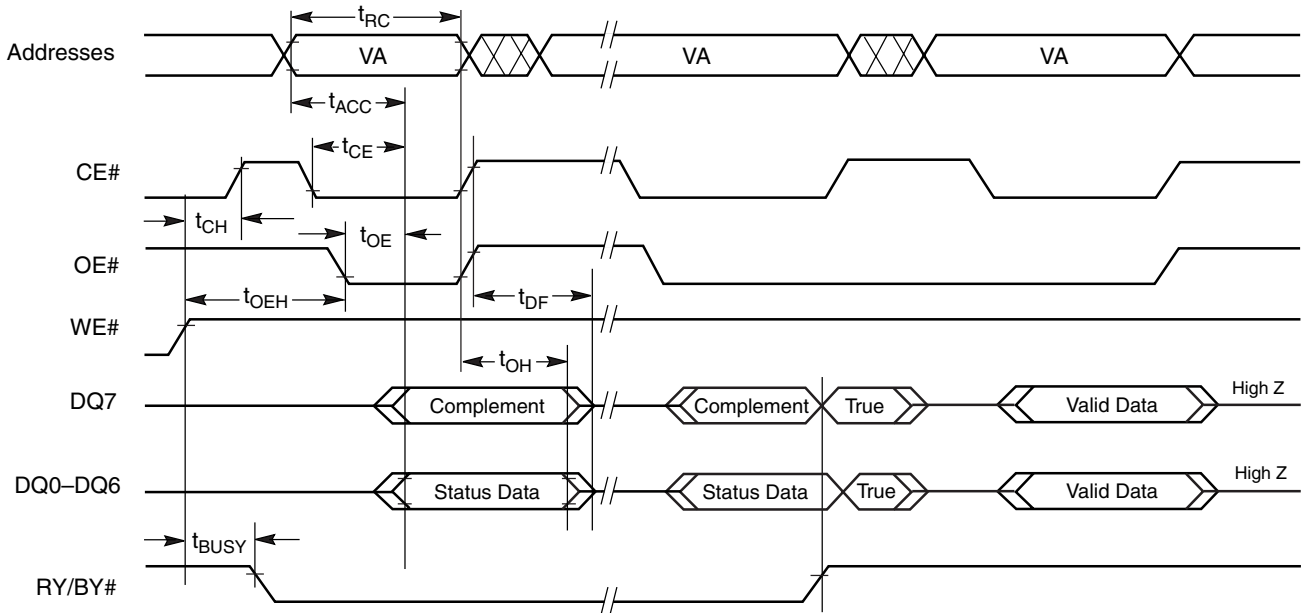

Figure 20. Back-to-back Read/Write Cycle Timings



Note: VA = Valid address. Illustration shows first status cycle after command sequence, last status read cycle, and array data read cycle.

Figure 21. Data# Polling Timings (During Embedded Algorithms)

AC CHARACTERISTICS

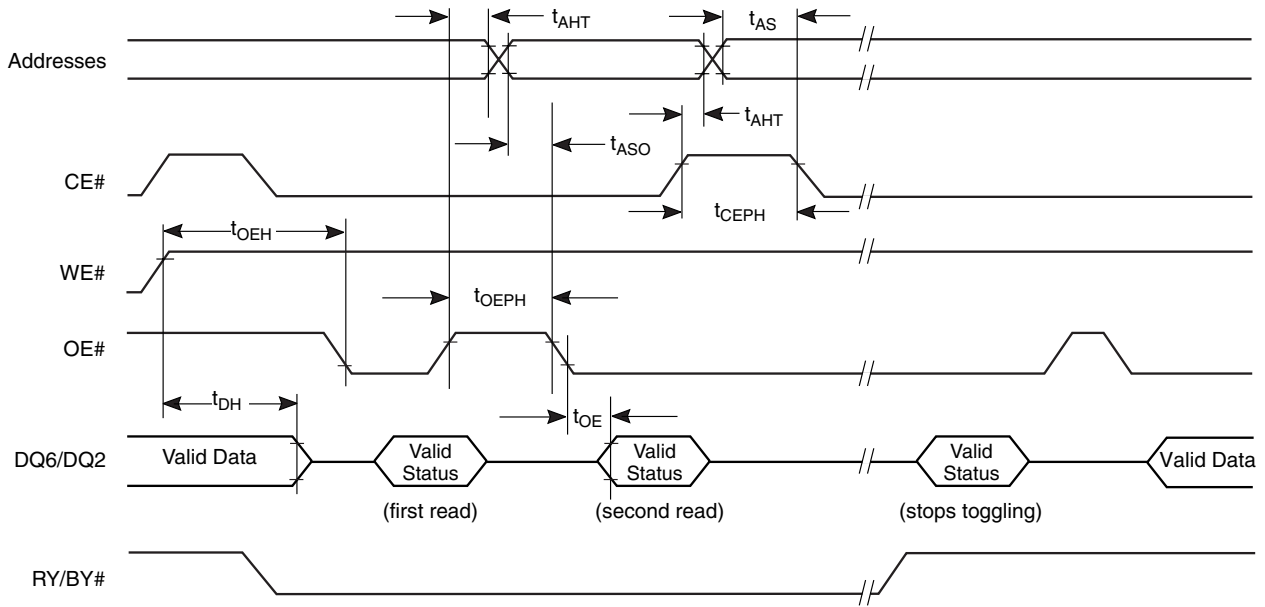

**Note:** VA = Valid address; not required for DQ6. Illustration shows first two status cycle after command sequence, last status read cycle, and array data read cycle

Figure 22. Toggle Bit Timings (During Embedded Algorithms)

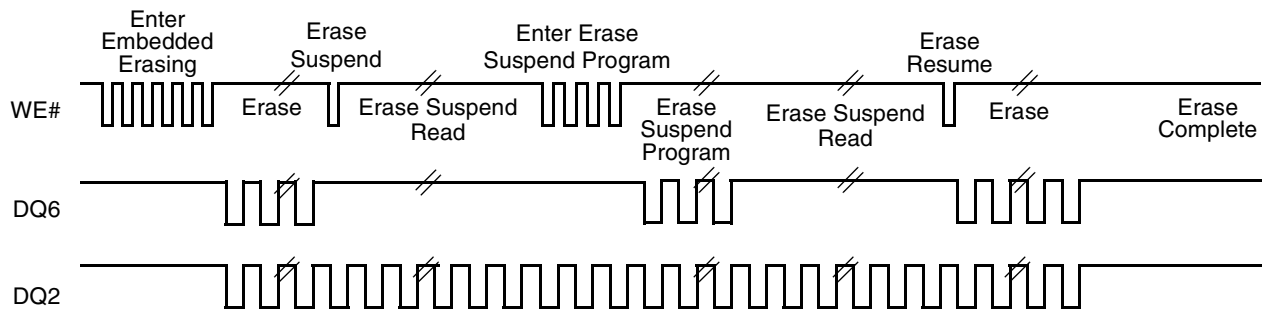

**Note:** DQ2 toggles only when read at an address within an erase-suspended sector. The system may use OE# or CE# to toggle DQ2 and DQ6.

Figure 23. DQ2 vs. DQ6

AC CHARACTERISTICS

Temporary Sector/Sector Block Unprotect

Parameter		Description		All Speed Options	Unit
JEDEC	Std				
	$t_{VIDR}$	$V_{ID}$ Rise and Fall Time (See Note)	Min	500	ns
	$t_{VHH}$	$V_{HH}$ Rise and Fall Time (See Note)	Min	250	ns
	$t_{RSP}$	RESET# Setup Time for Temporary Sector/Sector Block Unprotect	Min	4	$\mu$ s
	$t_{RRB}$	RESET# Hold Time from RY/BY# High for Temporary Sector/Sector Block Unprotect	Min	4	$\mu$ s

Note: Not 100% tested.

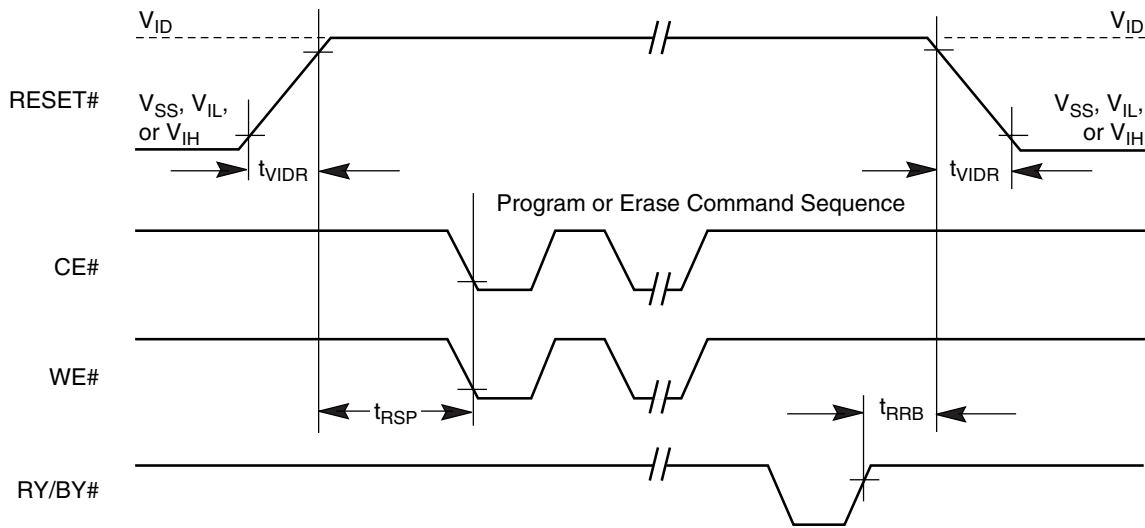
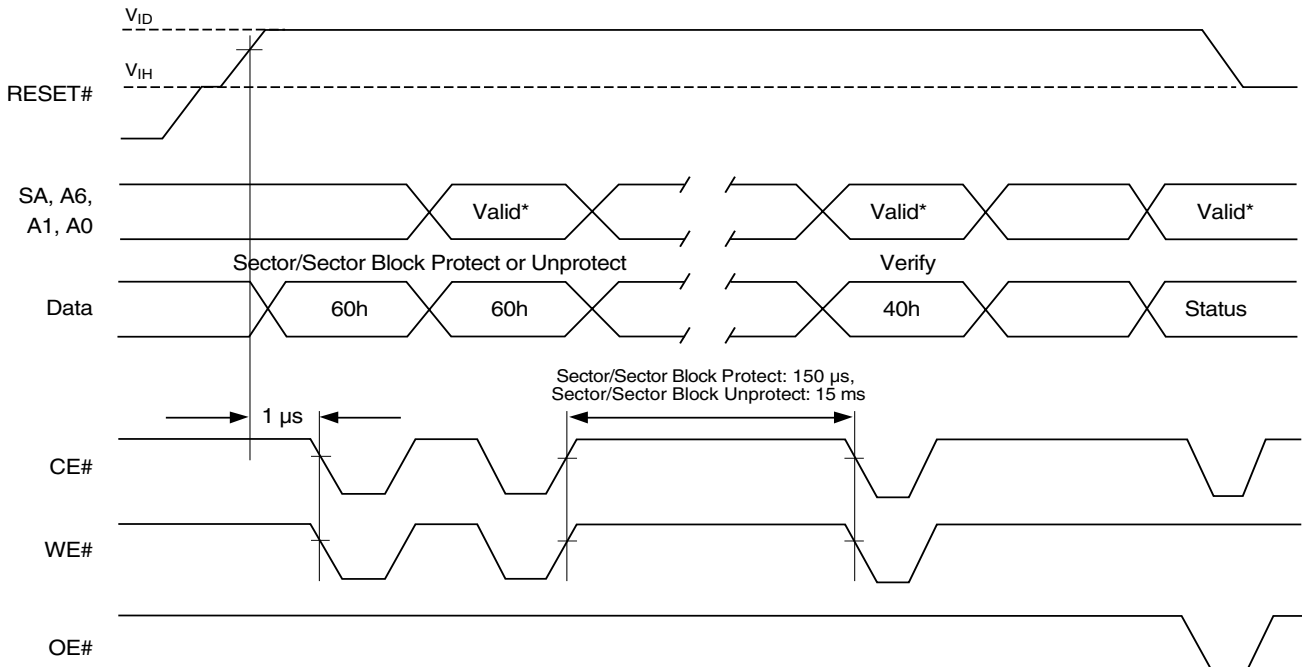

Figure 24. Temporary Sector/Sector Block Unprotect Timing Diagram

AC CHARACTERISTICS



\* For sector protect, A6 = 0, A1 = 1, A0 = 0. For sector unprotect, A6 = 1, A1 = 1, A0 = 0.

**Figure 25. Sector/Block Protect and Unprotect Timing Diagram**

## AC CHARACTERISTICS

### Alternate CE# Controlled Erase and Program Operations

Parameter		Description		Speed Options				Unit
JEDEC	Std			70	80	90	120	
$t_{AVAV}$	$t_{WC}$	Write Cycle Time (Note 1)	Min	70	80	90	120	ns
$t_{AVWL}$	$t_{AS}$	Address Setup Time	Min	0				ns
$t_{ELAX}$	$t_{AH}$	Address Hold Time	Min	45	45	45	50	ns
$t_{DVEH}$	$t_{DS}$	Data Setup Time	Min	35	35	45	50	ns
$t_{EHDx}$	$t_{DH}$	Data Hold Time	Min	0				ns
$t_{GHLE}$	$t_{GHLE}$	Read Recovery Time Before Write (OE# High to WE# Low)	Min	0				ns
$t_{WLEL}$	$t_{WS}$	WE# Setup Time	Min	0				ns
$t_{EHWH}$	$t_{WH}$	WE# Hold Time	Min	0				ns
$t_{ELEH}$	$t_{CP}$	CE# Pulse Width	Min	30	30	45	50	ns
$t_{EHEL}$	$t_{CPH}$	CE# Pulse Width High	Min	30	30	30	30	ns
$t_{WHWH1}$	$t_{WHWH1}$	Programming Operation (Note 2)	Byte	Typ				$\mu$ s
			Word	Typ				
$t_{WHWH1}$	$t_{WHWH1}$	Accelerated Programming Operation, Word or Byte (Note 2)	Typ	4				$\mu$ s
$t_{WHWH2}$	$t_{WHWH2}$	Sector Erase Operation (Note 2)	Typ	0.7				sec

**Notes:**

1. Not 100% tested.
2. See the "Erase And Programming Performance" section for more information.



AC CHARACTERISTICS

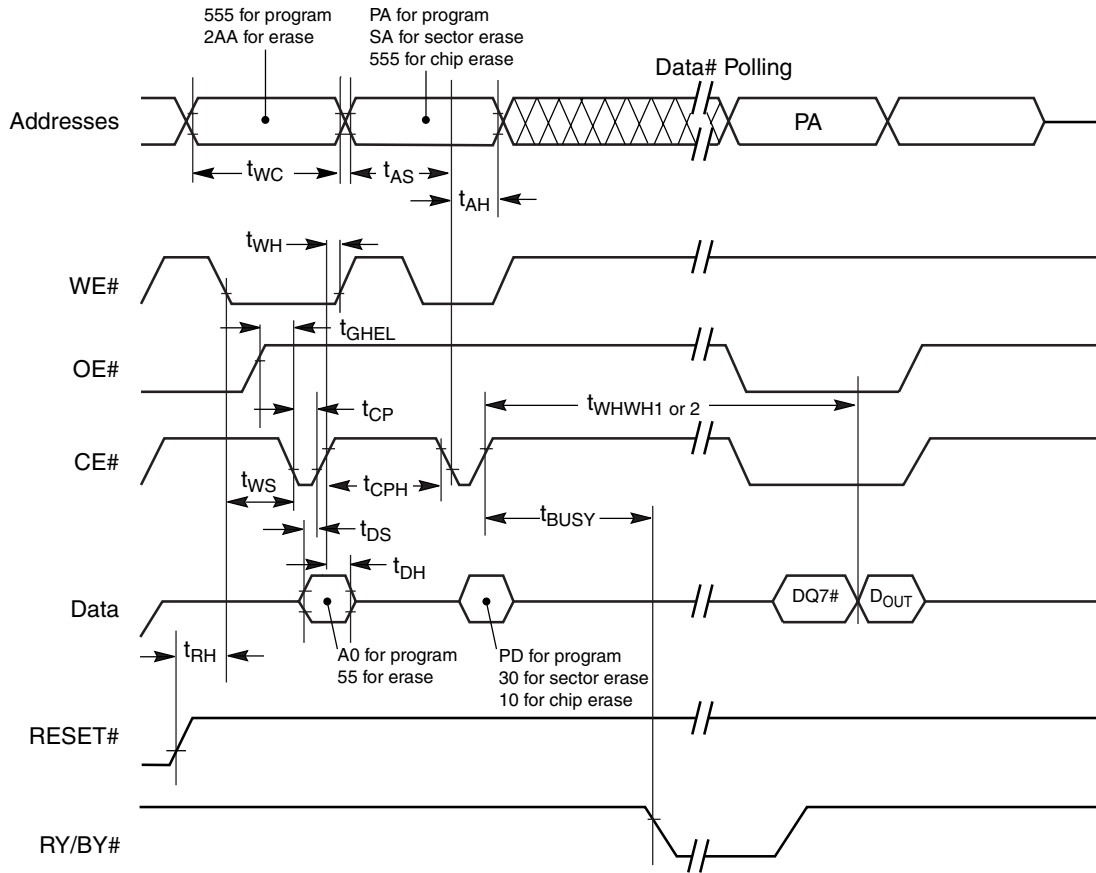

**Notes:**

1. Figure indicates last two bus cycles of a program or erase operation.
2. PA = program address, SA = sector address, PD = program data.
3. DQ7# is the complement of the data written to the device. D<sub>OUT</sub> is the data written to the device.
4. Waveforms are for the word mode.

**Figure 26. Alternate CE# Controlled Write (Erase/Program) Operation Timings**

## ERASE AND PROGRAMMING PERFORMANCE

Parameter	Typ (Note 1)	Max (Note 2)	Unit	Comments
Sector Erase Time	0.7	15	sec	Excludes 00h programming prior to erasure (Note 4)
Chip Erase Time	27		sec	
Byte Program Time	5	150	$\mu$ s	Excludes system level overhead (Note 5)
Word Program Time	7	210	$\mu$ s	
Accelerated Byte/Word Program Time	4	120	$\mu$ s	
Chip Program Time (Note 3)	Byte Mode	9	sec	
	Word Mode	6		

### Notes:

1. Typical program and erase times assume the following conditions: 25°C, 3.0 V  $V_{CC}$ , 1,000,000 cycles. Additionally, programming typicals assume checkerboard pattern.
2. Under worst case conditions of 90°C,  $V_{CC} = 2.7$  V, 1,000,000 cycles.
3. The typical chip programming time is considerably less than the maximum chip programming time listed, since most bytes program faster than the maximum program times listed.
4. In the pre-programming step of the Embedded Erase algorithm, all bytes are programmed to 00h before erasure.
5. System-level overhead is the time required to execute the two- or four-bus-cycle sequence for the program command. See Table 14 for further information on command definitions.
6. The device has a minimum erase and program cycle endurance of 1,000,000 cycles.

## LATCHUP CHARACTERISTICS

Description	Min	Max
Input voltage with respect to $V_{SS}$ on all pins except I/O pins (including A9, OE#, and RESET#)	-1.0 V	12.5 V
Input voltage with respect to $V_{SS}$ on all I/O pins	-1.0 V	$V_{CC} + 1.0$ V
$V_{CC}$ Current	-100 mA	+100 mA

**Note:** Includes all pins except  $V_{CC}$ . Test conditions:  $V_{CC} = 3.0$  V, one pin at a time.

## PACKAGE AND PIN CAPACITANCE

Parameter Symbol	Parameter Description	Test Setup	Typ	Max	Unit	
$C_{IN}$	Input Capacitance	$V_{IN} = 0$	TSOP/SO	6	7.5	pF
			BGA	4.2	5	pF
$C_{OUT}$	Output Capacitance	$V_{OUT} = 0$	TSOP/SO	8.5	12	pF
			BGA	5.4	6.5	pF
$C_{IN2}$	Control Pin Capacitance	$V_{IN} = 0$	TSOP/SO	7.5	9	pF
			BGA	3.9	4.7	pF

### Notes:

1. Sampled, not 100% tested.
2. Test conditions  $T_A = 25^\circ\text{C}$ ,  $f = 1.0$  MHz.

## DATA RETENTION

Parameter Description	Test Conditions	Min	Unit
Minimum Pattern Data Retention Time	150°C	10	Years
	125°C	20	Years

# PHYSICAL DIMENSIONS

## FBC048—48-Ball Fine-Pitch Ball Grid Array 8 x 9 mm package

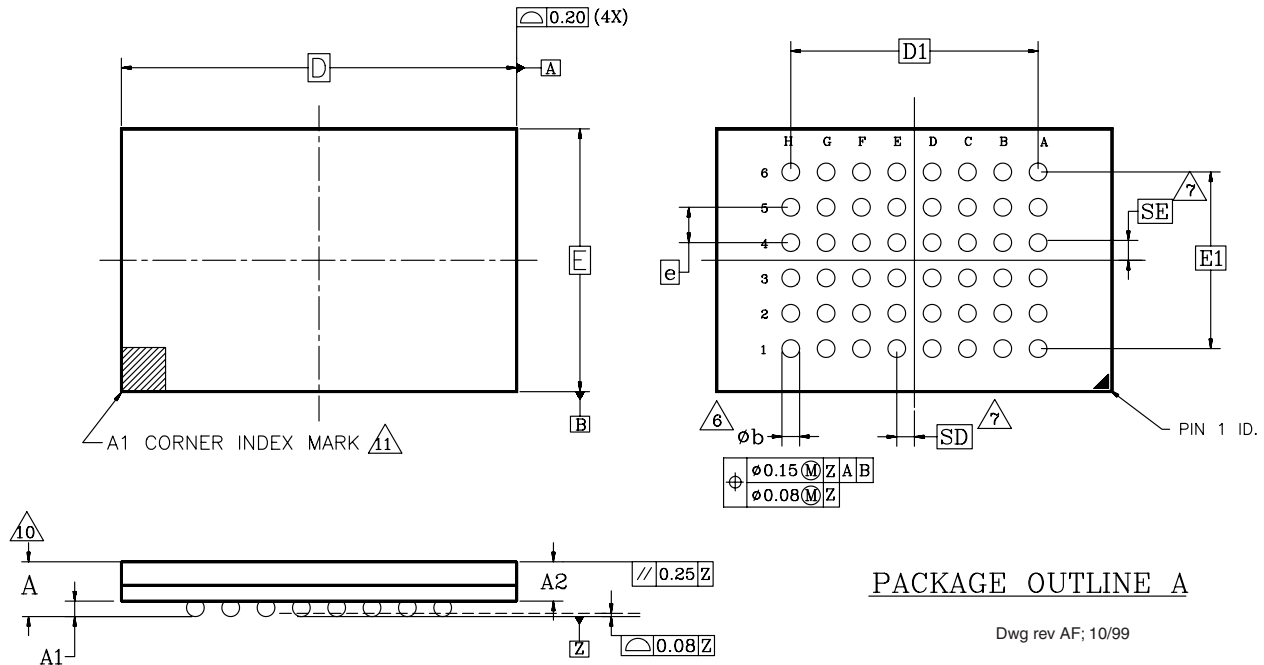

PACKAGE	FBC 048			NOTE
JEDEC	N/A			
	8.00mmx9.00mm PACKAGE			
SYMBOL	MIN	NOM	MAX	NOTE
A	—	—	1.20	OVERALL THICKNESS
A1	0.20	—	—	BALL HEIGHT
A2	0.84	—	0.94	BODY THICKNESS
D	9.00 BSC			BODY SIZE
E	8.00 BSC			BODY SIZE
D1	5.60 BSC			BALL FOOTPRINT
E1	4.00 BSC			BALL FOOTPRINT
MD	8			ROW MATRIX SIZE D DIRECTION
ME	6			ROW MATRIX SIZE E DIRECTION
N	48			TOTAL BALL COUNT
b	0.25	0.30	0.35	BALL DIAMETER
e	0.80 BSC			BALL PITCH
SD/SE	0.40 BSC			SOLDER BALL PLACEMENT

### NOTES:

- DIMENSIONING AND TOLERANCING PER ASME Y14.5M-1994.
- ALL DIMENSIONS ARE IN MILLIMETERS.
- BALL POSITION DESIGNATION PER JESD 95-1, SPP-010.
- [e] REPRESENTS THE SOLDER BALL GRID PITCH.
- SYMBOL "MD" IS THE BALL ROW MATRIX SIZE IN THE "D" DIRECTION. SYMBOL "ME" IS THE BALL COLUMN MATRIX SIZE IN THE "E" DIRECTION. N IS THE MAXIMUM NUMBER OF SOLDER BALLS FOR MATRIX SIZE MD x ME.
- DIMENSION "b" IS MEASURED AT THE MAXIMUM BALL DIAMETER IN A PLANE PARALLEL TO DATUM Z.
- SD AND SE ARE MEASURED WITH RESPECT TO DATUMS A AND B AND DEFINE THE POSITION OF THE CENTER SOLDER BALL IN THE OUTER ROW. WHEN THERE IS AN ODD NUMBER OF SOLDER BALLS IN THE OUTER ROW PARALLEL TO THE D OR E DIMENSION, RESPECTIVELY, SD OR SE = 0.000 WHEN THERE IS AN EVEN NUMBER OF SOLDER BALLS IN THE OUTER ROW, SD OR SE =  $e/2$
- "x" IN THE PACKAGE VARIATIONS DENOTES PART IS UNDER QUALIFICATION.
- "+" IN THE PACKAGE DRAWING INDICATE THE THEORETICAL CENTER OF DEPOPULATED BALLS.
- FOR PACKAGE THICKNESS A IS THE CONTROLLING DIMENSION.
- A1 CORNER TO BE IDENTIFIED BY CHAMFER, INK MARK, METALLIZED MARKINGS INDENTION OR OTHER MEANS.

# PHYSICAL DIMENSIONS

## LAA064—64-Ball Fortified Ball Grid Array, 13 x 11 mm package

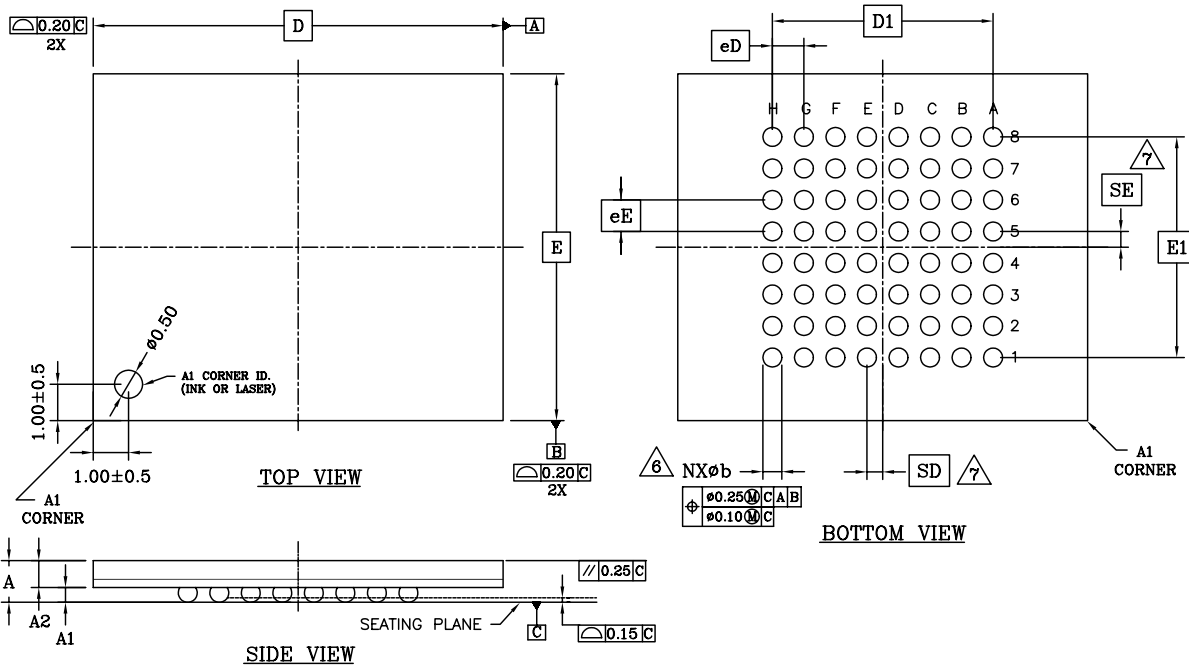

PACKAGE	LAA 064			
JEDEC	N/A			
	13.00x11.00 mm PACKAGE			
SYMBOL	MIN.	NOM.	MAX.	NOTE
A	—	—	1.40	PROFILE HEIGHT
A1	0.40	—	—	STANDOFF
A2	0.60	—	—	BODY THICKNESS
D	13.00 BSC.			BODY SIZE
E	11.00 BSC.			BODY SIZE
D1	7.00 BSC.			MATRIX FOOTPRINT
E1	7.00 BSC.			MATRIX FOOTPRINT
MD	8			MATRIX SIZE D DIRECTION
ME	8			MATRIX SIZE E DIRECTION
N	64			BALL COUNT
φb	0.50	0.60	0.70	BALL DIAMETER
eD	1.00 BSC.			BALL PITCH - D DIRECTION
eE	1.00 BSC.			BALL PITCH - E DIRECTION
SD/SE	0.50 BSC.			SOLDER BALL PLACEMENT
	A1-AB, K1-K8			DEPOPULATED SOLDER BALLS

### NOTES:

- DIMENSIONING AND TOLERANCING METHODS PER ASME Y14.5M-1994 .
- ALL DIMENSIONS ARE IN MILLIMETERS .
- BALL POSITION DESIGNATION PER JESD 95-1, SPP-010 (EXCEPT AS NOTED).
- [e] REPRESENTS THE SOLDER BALL GRID PITCH .
- SYMBOL "MD" IS THE BALL MATRIX SIZE IN THE "D" DIRECTION.  
SYMBOL "ME" IS THE BALL COLUMN MATRIX SIZE IN THE "E" DIRECTION.  
N IS THE NUMBER OF POPULATED SOLDER BALL POSITIONS FOR MATRIX SIZE MD X ME.
- △6 DIMENSION "b" IS MEASURED AT THE MAXIMUM BALL DIAMETER IN A PLANE PARALLEL TO DATUM "C".
- △7 SD AND SE ARE MEASURED WITH RESPECT TO DATUMS A AND B AND DEFINE THE POSITION OF THE CENTER SOLDER BALL IN THE OUTER ROW.  
WHEN THERE IS AN ODD NUMBER OF SOLDER BALLS IN THE OUTER ROW, SD OR SE = 0.000.  
WHEN THERE IS AN EVEN NUMBER OF SOLDER BALLS IN THE OUTER ROW, SD OR SE =  $\frac{e}{2}$
- "X" IN THE PACKAGE VARIATIONS DENOTES PART IS UNDER QUALIFICATION.
- "+" INDICATES THE THEORETICAL CENTER OF DEPOPULATED BALLS.

# PHYSICAL DIMENSIONS

## TS 048—48-Pin Standard TSOP

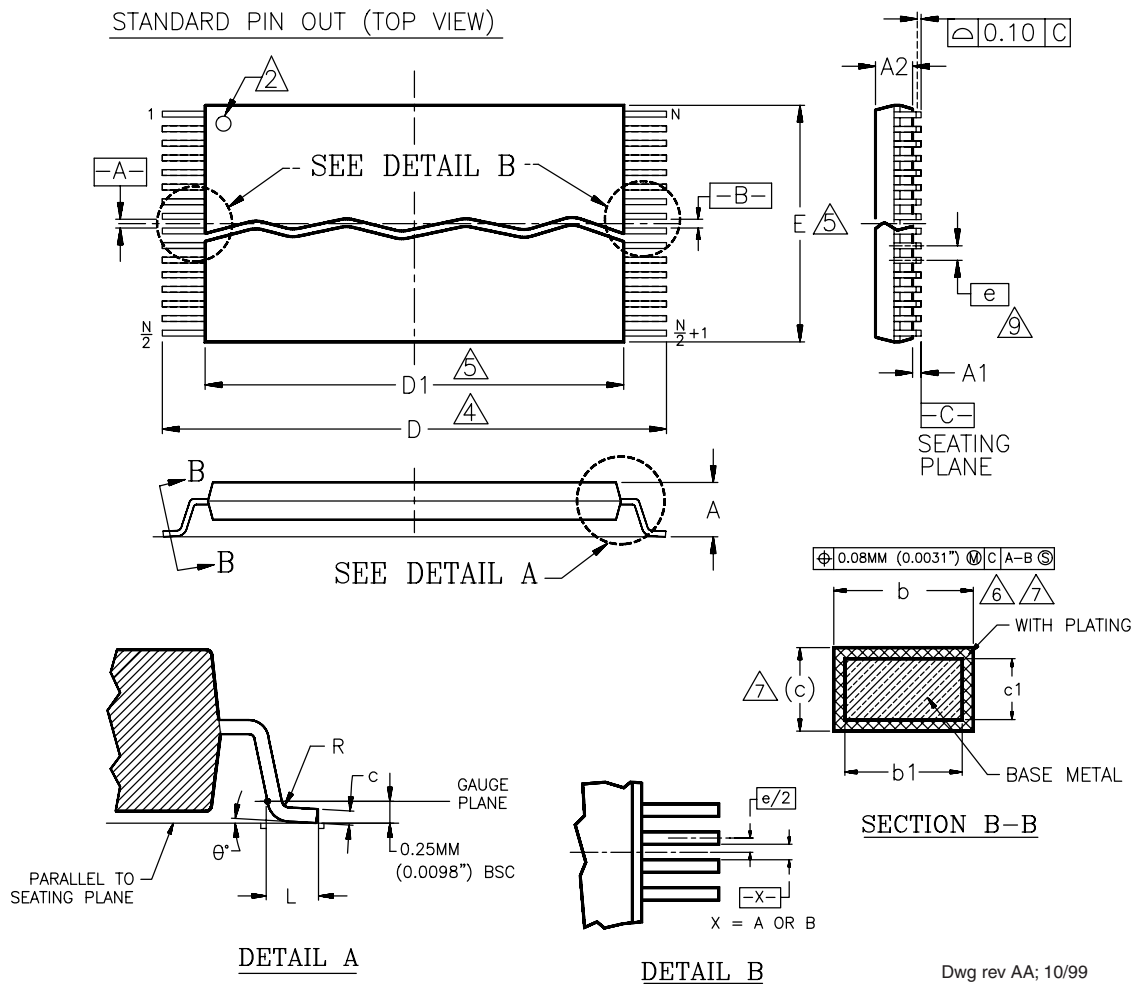

Dwg rev AA; 10/99

Package	TS 48		
Jedec	MO-142 (B) DD		
Symbol	MIN	NOM	MAX
A	—	—	1.20
A1	0.05	—	0.15
A2	0.95	1.00	1.05
b1	0.17	0.20	0.23
b	0.17	0.22	0.27
c1	0.10	—	0.16
c	0.10	—	0.21
D	19.80	20.00	20.20
D1	18.30	18.40	18.50
E	11.90	12.00	12.10
e	0.50 BASIC		
L	0.50	0.60	0.70
θ	0°	3°	5°
R	0.08	—	0.20
N	48		

### NOTES:

- ① CONTROLLING DIMENSIONS ARE IN MILLIMETERS (mm). (DIMENSIONING AND TOLERANCING CONFORMS TO ANSI Y14.5M-1982)
- ② PIN 1 IDENTIFIER FOR STANDARD PIN OUT (DIE UP).
- ③ PIN 1 IDENTIFIER FOR REVERSE PIN OUT (DIE DOWN); INK OR LASER MARK.
- ④ TO BE DETERMINED AT THE SEATING PLANE  $\boxed{C}$ . THE SEATING PLANE IS DEFINED AS THE PLANE OF CONTACT THAT IS MADE WHEN THE PACKAGE LEADS ARE ALLOWED TO REST FREELY ON A FLAT HORIZONTAL SURFACE.
- ⑤ DIMENSIONS D1 AND E DO NOT INCLUDE MOLD PROTRUSION. ALLOWABLE MOLD PROTRUSION IS 0.15mm (0.0059") PER SIDE.
- ⑥ DIMENSION b DOES NOT INCLUDE DAMBAR PROTRUSION. ALLOWABLE DAMBAR PROTRUSION SHALL BE 0.08mm (0.0031") TOTAL IN EXCESS OF b DIMENSION AT MAX. MATERIAL CONDITION. MINIMUM SPACE BETWEEN PROTRUSION AND AN ADJACENT LEAD TO BE 0.07mm (0.0028").
- ⑦ THESE DIMENSIONS APPLY TO THE FLAT SECTION OF THE LEAD BETWEEN 0.10mm (0.0039") AND 0.25mm (0.0098") FROM THE LEAD TIP.
8. LEAD COPLANARITY SHALL BE WITHIN 0.10mm (0.004") AS MEASURED FROM THE SEATING PLANE.
- ⑨ DIMENSION "e" IS MEASURED AT THE CENTERLINE OF THE LEADS.

PHYSICAL DIMENSIONS

VBF048—48-Ball Very Thin Profile Fine-Pitch Ball Grid Array

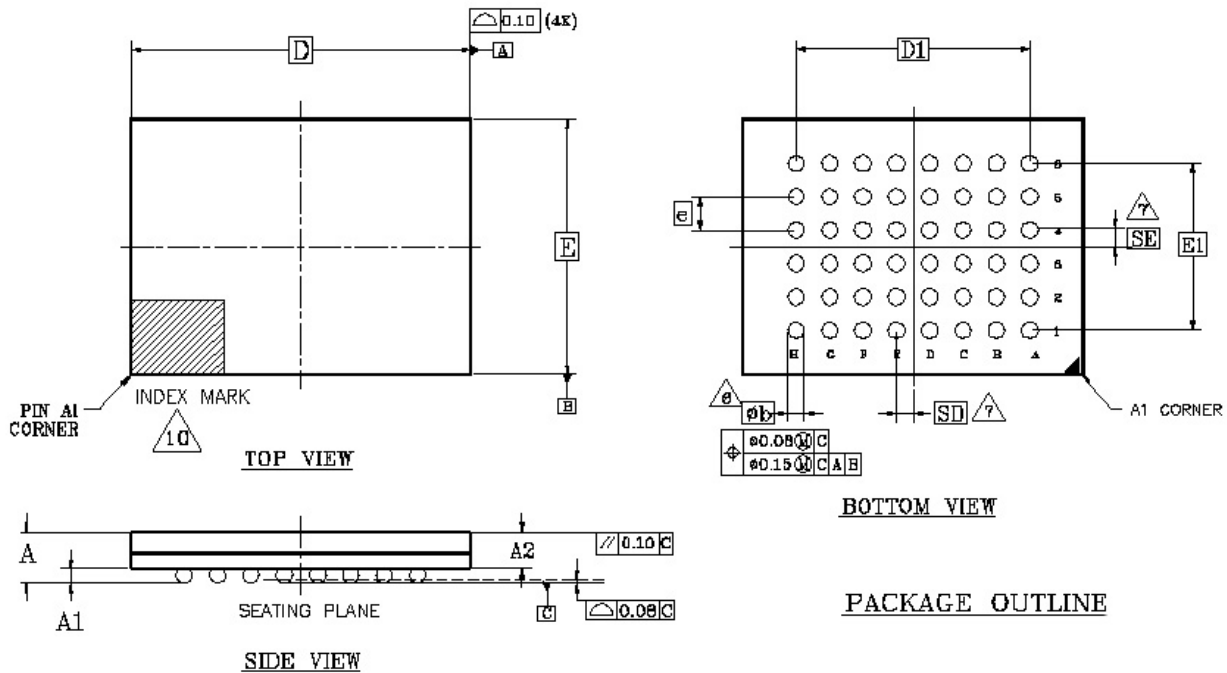

PACKAGE	XVBF 048			
JCDEC	N/A			
	8.15mm x 6.15mm NOM PACKAGE			
SYMBOL	MIN.	NOM.	MAX.	NOTE
A	—	—	1.00	OVERALL THICKNESS
A1	0.20	—	—	BALL HEIGHT
A2	0.62	—	0.76	BODY THICKNESS
D	8.15 BSC.			BODY SIZE
E	6.15 BSC.			BODY SIZE
D1	5.60 BSC.			BALL FOOTPRINT
E1	4.00 BSC.			BALL FOOTPRINT
MD	8			ROW MATRIX SIZE D DIRECTION
ME	6			ROW MATRIX SIZE E DIRECTION
N	48			TOTAL BALL COUNT
φb	0.30	0.35	0.40	BALL DIAMETER
a	0.80 BSC.			BALL PITCH
SD/SE	0.40 BSC.			SOLDER BALL PLACEMENT
				DEPOPULATED SOLDER BALLS
	J			PACKAGE OUTLINE TYPE

NOTES:

1. DIMENSIONING AND TOLERANCING PER ASME Y14.5M-1994.
  2. ALL DIMENSIONS ARE IN MILLIMETERS.
  3. BALL POSITION DESIGNATION PER JEDEC 95-1, SPP-010 (EXCEPT AS NOTED).
  4. □ REPRESENTS THE SOLDER BALL GRID PITCH.
  5. SYMBOL "MD" IS THE BALL ROW MATRIX SIZE IN THE "D" DIRECTION. SYMBOL "ME" IS THE BALL COLUMN MATRIX SIZE IN THE "E" DIRECTION. N IS THE TOTAL NUMBER OF SOLDER BALLS.
- ⚠ DIMENSION "b" IS MEASURED AT THE MAXIMUM BALL DIAMETER IN A PLANE PARALLEL TO DATUM C.
- ⚠ SD AND SE ARE MEASURED WITH RESPECT TO DATUMS A AND B AND DEFINE THE POSITION OF THE CENTER SOLDER BALL IN THE OUTER ROW. WHEN THERE IS AN ODD NUMBER OF SOLDER BALLS IN THE OUTER ROW PARALLEL TO THE D OR E DIMENSION, RESPECTIVELY, SD OR SE = 0.000.
- WHEN THERE IS AN EVEN NUMBER OF SOLDER BALLS IN THE OUTER ROW, SD OR SE =  $\frac{e}{2}$
6. "X" IN THE PACKAGE VARIATIONS DENOTES PART IS UNDER QUALIFICATION.
  7. "+" INDICATES THE THEORETICAL CENTER OF DEPOPULATED BALLS.
  8. A1 CORNER TO BE IDENTIFIED BY CHAMFER, LASER OR INK MARK, METALLIZED MARK INDENTATION OR OTHER MEANS.

## REVISION SUMMARY

### Revision A (September 1998)

Initial release.

### Revision B (October 1998)

#### Global

Deleted the 90R and 120R speed options. Expanded the full voltage range to 2.7–3.6 V.

#### Distinctive Characteristics

Added 125°C to 20-year data retention bullet.

#### Connection Diagrams

Changed the FBGA diagram from bottom view to top view.

#### Ordering Information

Changed the FBGA ordering nomenclature to “YC.” The package designation is now FBC048. Reverted to WC in Revision C.

#### DC Characteristics

Changed maximum  $I_{LI}$  current to  $\pm 3.0 \mu A$ .

#### Physical Dimensions

Updated the FBGA drawing, table, and notes. The package designation is now FBC048. Deleted 40-pin TSOP drawing.

### Revision B+1 (October 1998)

#### Command Definitions table

Added the term “sector block” to the notes where appropriate.

#### DC Characteristics

Changed maximum  $I_{LI}$  current to  $\pm 1.0 \mu A$ .

#### AC Characteristics

*Temporary Sector Unprotect:* Moved the accelerated program timing diagram to follow the program operations timings. Added the term “sector block” where appropriate elsewhere on the page.

### Revision C (January 1998)

#### Global

Changed data sheet title.

#### Product Selector Guide

Replaced “Full Voltage Range:  $V_{CC} = 2.7\text{--}3.6 \text{ V}$ ” with “Standard Voltage Range:  $V_{CC} = 2.7\text{--}3.3 \text{ V}$ .” Each part number now has a separate set of speed options.

#### Ordering Information

Added 70, 90R, and 120R speed options to the valid combination table. Reverted FBGA designator back to WC.

#### SecSi (Secured Silicon) Sector Flash Memory Region

*Factory Locked: SecSi Sector Programmed and Protected at the Factory:* Corrected the address range of the ESN and distinguished between word and byte modes.

#### Operating Ranges

*V<sub>CC</sub> Supply Voltages:* Replaced single voltage range with voltage ranges for standard and regulated devices.

### Revision C+1 (March 19, 1999)

#### SecSi (Secured Silicon) Sector Flash Memory Region

Customer Lockable subsection: In the bullets, text should refer to “Enter SecSi Sector Region command sequence.”

### Revision C+2 (June 14, 1999)

Changed data sheet status to Preliminary.

### Revision C+3 (August 9, 1999)

#### Global

Added Am29DL164 specifications to the document.

#### Ordering Information

Added the 70R speed option for the DL163, deleted the SSOP for the DL162.

#### Test Specifications table

The 90 ns speed option is tested at 100 pF loading.

### Revision C+4 (August 23, 1999)

#### Ordering Information

*Temperature Range:* Added “C = Commercial (0°C to +70°C)”.

#### Operating Ranges

Added commercial device.

### Revision C+5 (October 18, 1999)

#### Device Bus Operations

*Autoselect Mode:* Added Am29DL164 device IDs to the Autoselect Codes table.

## Revision D (February 22, 2000)

### Global

The Am29DL16x family has migrated to a new 0.23  $\mu\text{m}$  process technology, which is indicated by a “D” in the ordering part number. All references in this document have been changed to reflect the new process.

### Distinctive Characteristics

Under “Performance Characteristics,” the typical accelerated programming time was changed to match the AC tables.

### AC Characteristics

*Figure 17, Program Operations Timing; Figure 19, Chip/Sector Erase Operations:* Deleted  $t_{\text{GHWL}}$  and changed OE# waveform to start at high.

*Erase and Program Operations table; Alternate CE# Controlled Erase and Program Operations table:* Changed the typical and maximum specifications for programming time.

### Erase and Programming Performance

In the table, changed the typical and maximum specifications for programming time. The typical and maximum chip programming times in both byte and word modes are reduced.

### Physical Dimensions

Replaced figures with more detailed illustrations.

## Revision D+1 (June 21, 2000)

### Global

Data sheet designation has changed from “Advance Information” to “Preliminary.”

Deleted references to the 56-pin SSOP and the corresponding 70R speed option.

### Ordering Information

Added valid combinations for the Am29DL164D device in TSOP. Added valid combinations for the Am29DL162D devices in TSOP and FBGA packages. Deleted valid combinations for the 80 ns Am29DL164D device in FBGA package.

### Device Bus Operations

*Table 3, Sector Addresses for Top Boot Sector Devices:* In note below table, corrected last device part number to top boot.

*Table 7, Autoselect Codes:* The SecSi Sector Indicator Bit values have changed from 80h and 00h to 81h and 01h, respectively.

### Command Definitions

*Table 14, Command Definitions:* The SecSi Sector Indicator Bit values have changed from 80h and 00h to 81h and 01h, respectively.

### AC Characteristics

*Read-only Operations table:* Changed parameter  $t_{\text{DF}}$  to 16 ns for all speed options. Added Note 3.

## Revision D+2 (September 4, 2000)

Deleted remaining references to 80 ns speed option, which was officially removed in Revision D+1. Corrected references to Am29DL16xC, which officially changed to Am29DL16xD in Revision D.

## Revision D+3 (November 22, 2000)

### Global

Deleted Preliminary status from document. Added table of contents.

## Revision E (July 2, 2001)

Added Am29DL161D device to data sheet. Deleted extended temperature range devices.

### Sector/Sector Block Protection and Unprotection

Noted that sectors are unprotected in parallel.

### SecSi™ (Secured Silicon) Sector Flash Memory Region

Noted changes for upcoming versions of these devices: reduced SecSi Sector size and deletion of SecSi Sector erase functionality. Current versions of these devices remain unaffected.

## Revision E+1 (July 29, 2002)

### Global

Added 64-ball Fortified BGA package.

### Command Definitions

Modified caution to state that incorrect command/sequences may place device in unknown state, upon which device must be reset.

### Unlock Bypass Command Sequence; Command Definitions table

Corrected table and description to indicated that bank address is not required for unlock bypass reset.

### Package Capacitance

Added BGA capacitance specifications.



---

**Revision E + 2 (February 14, 2003)****Global**

Added VBF048 package, Very Thin Profile Fine Pitch Ball Grid Array, to Distinctive Characteristics, General Description, Ordering Information, Connection Diagrams, and Physical Dimensions sections.

**Revision E+3 (February 25, 2004)****AC Characteristics**

Corrected  $t_{SRW}$  in Figure 20, Back-to-back Read/Write Cycle Timings.

**Trademarks**

Copyright © 2004 Advanced Micro Devices, Inc. All rights reserved.

AMD, the AMD logo, and combinations thereof are registered trademarks of Advanced Micro Devices, Inc.

ExpressFlash is a trademark of Advanced Micro Devices, Inc.

Product names used in this publication are for identification purposes only and may be trademarks of their respective companies.