

NL27WZ04 Dual Gate Inverter Oscillator Increases the Brightness of LEDs While Reducing Power Consumption

Prepared by: Jim Lepkowski
Senior Applications Engineer
Mike Hoogstra
JTL Design
Christopher Young
Arizona State University



ON Semiconductor™

<http://onsemi.com>

APPLICATION NOTE

INTRODUCTION

ON Semiconductor's new family of two-gate logic devices offer space saving solutions to the logic designer. The LV-CMOS two gate logic family consists of inverters, buffers and logic gates in both the SC-88 and TSOP-6 package. These versatile devices have several features including a wide 2.3 V to 5.5 V operating voltage range, low quiescent power supply current and an output capable of sinking or sourcing 24 mA.

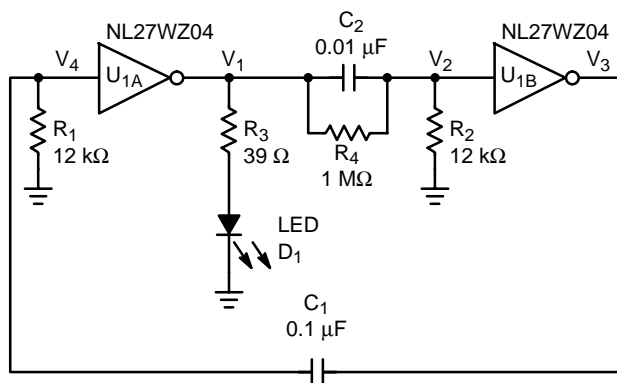

Figure 1. LED Oscillator Circuit

The versatile features of the two gate devices will be demonstrated by using the NL27WZ04 dual inverter IC to create the Light Emitting Diode (LED) oscillator shown in Figure 1. An oscillator can be used to increase the brightness of an LED without increasing the system's power requirements. The brightness of an LED is directly proportional to the current through the LED, which creates a challenge for low voltage and battery powered applications. Thus, a high peak current is required to obtain a bright LED, while a low average current is needed to minimize the power consumption. The LED oscillator

circuit achieves these requirements by providing a low duty cycle waveform with a short duration "ON" time and a long "OFF" time.

Light Emitting Diodes

LEDs are manufactured out of a variety of semiconductor materials and are comprised of a "P" and "N" type junction, which establishes a voltage potential across the junction. The LED provides a light output when the diode is forward biased, causing current to flow through the device. The forward voltage (V_f) of the diode will be different for the various materials and colors and ranges from approximately 1.5 V for red to 3.3 V for blue LEDs.

A pulsating LED drive circuit can enhance the light output of an LED by using a peak current of a much higher level than sustainable under direct drive conditions [1][2]. A high peak current pulse of short duration with a "OFF" period between pulses allows time for the LED's junction to cool down. High drive currents can result in a degradation of the light output and the life expectancy (time to half light output) of an LED. However, the reduction in the life of a pulsed LED is minimal if the peak current is below the maximum current limit specified for the device.

Why Are Pulsed LEDs Brighter Than DC LEDs?

There are two main reasons why LEDs are brighter when pulsed. First, the human eye functions as both a peak detector and an integrator; therefore, the eye perceives a pulsed LED's brightness somewhere between the peak and the average brightness [4]. Thus, an LED driven by a high intensity low duty cycle light looks brighter in a pulsed circuit compared to a DC drive circuit that is equal to the average of the pulsed signal.

The second factor controlling the improved brightness is shown in the relative efficiency versus peak current curves of an LED. Figure 2 shows the efficiency curves for the

Agilent Technologies HLMP subminiature LED lamps [3]. For example, the pulsed emerald green LED will have a light output approximately 30% brighter than the equivalent DC drive circuit at a peak pulsed current of 30 mA. Note that the pulsed circuit does not always produce a brighter LED. The pulsed emerald green LED has a brighter light output at peak currents greater than 10 mA; however, the DC circuit produces a brighter LED for peak currents less than 10 mA.

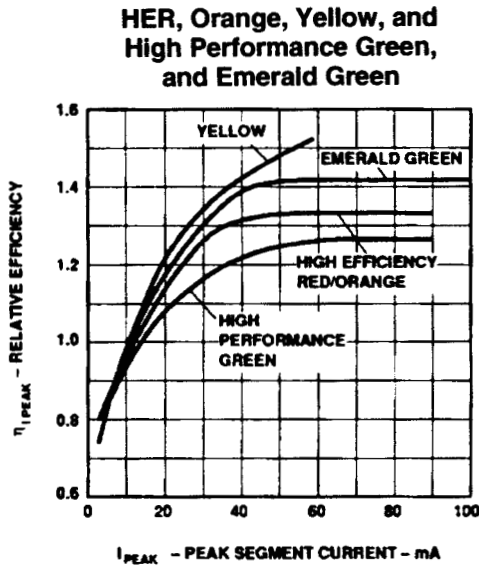

Figure 2. LED Efficiency – Pulsed vs. DC Operation

LED Drive Techniques

DC Method

Single LEDs are often driven using either a high side or low side switch. The conventional LED interface circuit consists of an open collector/drain driver to sink the LED current as shown in Figure 3. The brightness of the LED is proportional to the current (I_f) through the diode. The current through the LED for a current sinking configuration is calculated using V_{CC} , V_f , R , and the voltage drop across the driver (V_{Switch}) as shown below.

$$I_f = \frac{V_{CC} - V_f - V_{Switch}}{R}$$

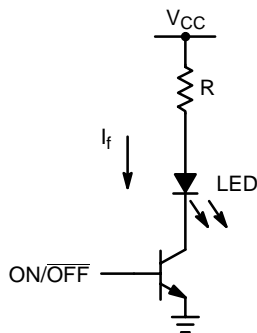

Figure 3. Conventional Open Collector DC LED Circuit

AC Method

The second method to drive LEDs uses a pulsating square wave voltage. The suggested frequency and duty cycle varies for different LEDs; however, the typical frequency used is 1 kHz with a 10 to 30% duty cycle. Pulsing LEDs is the standard method used with multiplexed displays when a single driver circuit is interfaced to multiple LEDs. The current through a pulsed current sourcing driver such as the oscillator circuit shown in Figure 1 is calculated as shown below.

$$I_f = \left(\frac{V_{OH} - V_f}{R} \right) \times \text{Duty Cycle}$$

(current sourcing driver)

The equation for a current sinking AC driver is similar to the DC method, except that the duty cycle is used to reduce the current consumption.

$$I_f = \left(\frac{V_{CC} - V_f - V_{Switch}}{R} \right) \times \text{Duty Cycle}$$

(current sinking driver)

Dual Gate Inverter Oscillator Circuit

The LED oscillator circuit, shown in Figure 1 is derived from the conventional two-inverter oscillator shown in Figure 4. The conventional oscillator is often denoted as an astable multivibrator and has a duty cycle of approximately 50%. In contrast, the LED oscillator circuit has two RC time constants so that both the duty cycle and frequency can be adjusted. R_2 and C_2 control the “ON” time of the LED pulse, while R_1 and C_1 control the “OFF” time.

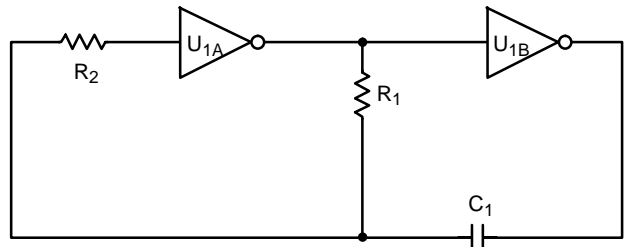

$$f_{Oscillation} \cong \frac{1}{2.3R_1C_1} \quad (R_2 = 10R_1)$$

Figure 4. Conventional Inverter Oscillator

The LED oscillator with the NL27WZ04 dual gate inverter and the given RC values is stable and does not have the oscillation start-up problem that often occurs with the conventional two inverter oscillator. In order to ensure oscillation at power-up, R_4 was added in parallel with C_2 to provide a DC path through the capacitor. The parallel impedance combination of R_4 and C_2 is effectively equal to the impedance of C_2 at the oscillation frequency; therefore, R_4 does not effect the oscillation frequency.

The NL27WZ04 dual inverter is a standard buffered inverter that produces either a “high” (i.e. V_{CC}) or a “low”

(i.e. Ground) output voltage. In contrast, an unbuffered inverter such as the NL27WZU04 functions as a voltage amplifier for a small input voltage and thus can provide a sine wave output during the oscillation start-up period. It is recommended that higher frequency oscillator applications, such as a clock generation circuit, use the unbuffered inverters.

The LED oscillator circuit shown in Figure 1 can be used as a “Power ON” indicator. If NAND gates are used instead of the inverters, ON/OFF control can be implemented for applications such as status indicator lamps. This oscillator circuit, shown in Figure 5, could be constructed using ON Semiconductor’s One-Gate Logic family NAND devices. The MC74VHC1G00 is the 2-input NAND and the MC74VHC1G01 is the 2-input NAND with an open drain output.

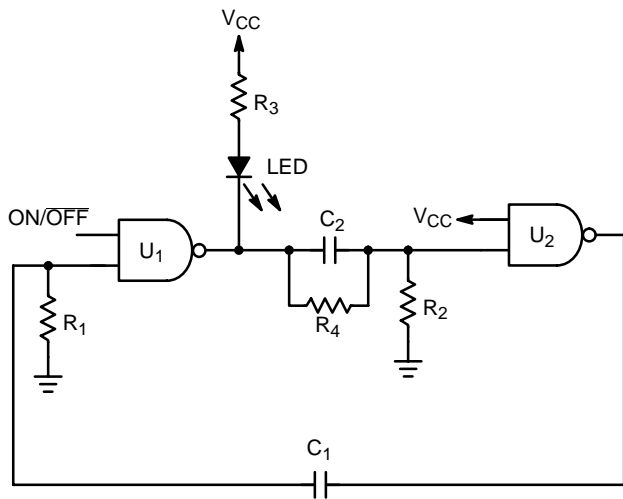

Figure 5. LED Oscillator Circuit with ON/OFF Control

Figure 6 shows V_1 , the LED drive voltage of the output of inverter U_{1A} . The input voltage V_2 to inverter U_{1B} is shown in Figure 7. Note that the voltage at V_2 may ring above V_{CC} and below ground for a short duration because of capacitor C_2 . The NL27WZ04 dual inverter has an absolute DC input voltage rating of -0.5 V to 7 V . The maximum ratings are specified at a steady state condition and the RMS value of the high and low sides of the V_2 are within the input voltage specification. The voltage at V_2 swings below ground; however, the RMS value of the minimum voltage level is equal to only approximately -50 mV .

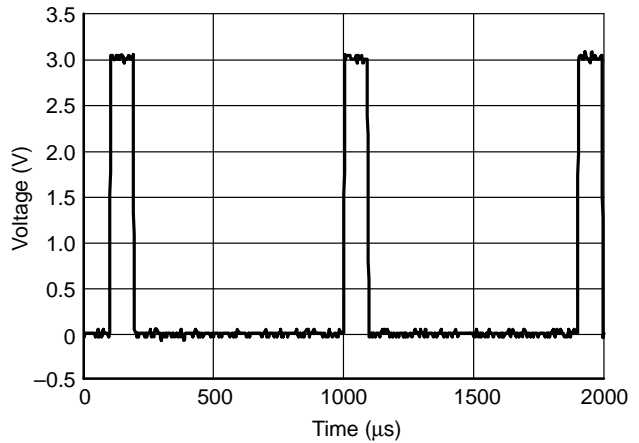

Figure 6. V_1 , Output Voltage of Inverter U_{1A} ($V_{CC} = 3.3\text{ V}$)

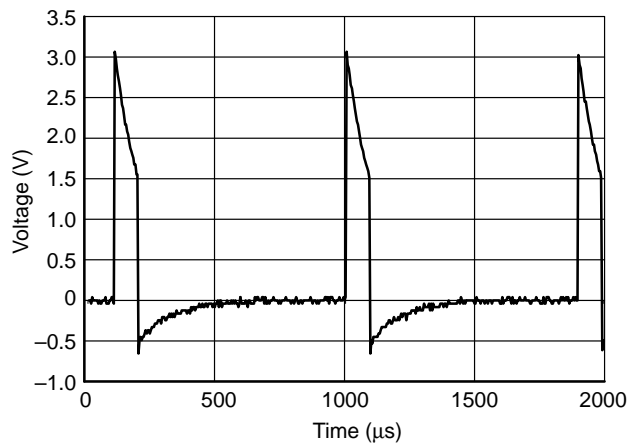

Figure 7. V_2 , Input Voltage of Inverter U_{1B} ($V_{CC} = 3.3\text{ V}$)

Oscillation Equations for the Dual Inverter Oscillator

The oscillation frequency and duty cycle of the oscillator are obtained by analyzing the oscillator as two separate circuits. The inverter subcircuits, shown in Figures 8 and 9, are analyzed to obtain equations for the discharge times of the RC networks formed at each inverter. In order to simplify the calculation R_3 , R_4 and the LED will not be included in the analysis. The error that results from neglecting these components in the equations is small. In addition, the input impedance of the inverter connected to the RC network can be neglected because the input capacitance (C_{IN}) for the CMOS device is specified at only 2.5 pF .

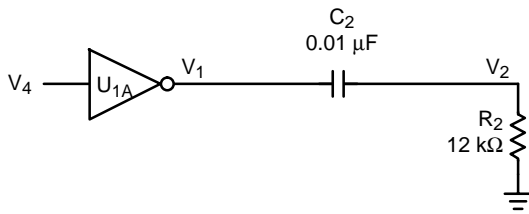

Figure 8. "ON" Time Oscillator Subcircuit

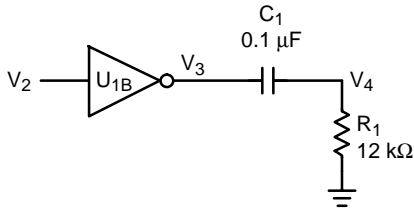

Figure 9. "OFF" Time Oscillator Subcircuit

The equations are developed to predict the time it takes the RC circuits to discharge to the threshold switching voltage of the inverter. The threshold voltage of the inverters will be assumed to be one-half the supply voltage, which is equal to the average of the High-Level-Input Voltage (V_{IH}) and the Low-Level Input Voltage (V_{IL}). The NL27WZ04 specifies V_{IH} as $0.7 \times V_{CC}$ (minimum) and V_{IL} as $0.3 \times V_{CC}$ (maximum). In addition, the initial voltage or the output "High" voltage (V_{OH}) of the inverter is assumed to be equal to V_{CC} . The actual V_{OH} value is a function of the output current and decreases as the output current increases.

The general equation for a RC circuit discharging to a logic switching threshold voltage (V_{th}) with an initial voltage (V_i) is as follows.

$$V_{th} = V_i \times e^{\frac{-t}{R \cdot C}}$$

These assumptions result in the equation listed below that can be solved for time (t).

Assume

$$V_{th} = 0.5 \times V \quad \text{and} \quad V_i = V_{OH} \cong V_{CC}$$

Then

$$t = -RC \ln\left(\frac{V_{th}}{V_{CC}}\right) = -RC \ln\left(\frac{0.5 \times V_{CC}}{V_{CC}}\right)$$

$$\cong 0.693 \times RC$$

LED "ON" Time

The LED's "ON" time is controlled by the discharge time t_1 at inverter U_{1A} , as shown from the equation listed below.

$$t_1 \cong 0.693 \times R_2 C_2$$

Substituting values into the equation yields:

$$t_1 \cong 0.693 \times (12000 \Omega)(0.01 \mu F) \cong 83.2 \mu s$$

LED "OFF" Time

The LED's "OFF" time is controlled by the discharge time t_2 at inverter U_{1B} , as shown from the equation listed below.

$$t_2 \cong 0.693 \times R_1 C_1$$

Substituting the values into the equation yields:

$$t_2 \cong 0.693 \times (12000 \Omega)(0.1 \mu F) \cong 832 \mu s$$

LED Oscillation Frequency

The time period (T) of the oscillator is equal to the sum of the charge times in the first and second RC stages. Note the propagation delay of the inverters can be ignored at the LED circuit's oscillation frequency of 1 kHz.

$$T = t_1 + t_2$$

$$T = 83.2 \mu s + 832 \mu s = 915 \mu s$$

$$f = \frac{1}{T} = \frac{1}{915 \mu s} = 1.09 \text{ kHz}$$

LED Duty Cycle

The duty cycle (DS) for the oscillator at V_1 is given by the equation:

$$DS_{V1} = \left(\frac{t_1}{t_2}\right) \times 100\%$$

The duty cycle of the oscillator is proportional to the ratio of the two time constants that are set by capacitors C_1 and C_2 . The LED oscillator has a duty cycle of ten percent as shown below.

$$DS_{V1} = \left(\frac{83.2 \mu s}{832 \mu s}\right) \times 100\% = 10\%$$

Experimental Results

The operating characteristics of the pulsed LED oscillator circuit were compared to the DC circuit shown in Figure 10. The DC circuit's current limiting resistor R_5 was selected so the current through the LED was equal to the average (RMS) current of the oscillator circuit's LED. A high efficiency green GaP/GaP LED from Chicago Miniature Lamp (part number CMD64531) was used to evaluate the circuits. The resistor and capacitor values are listed below.

Component Values

LED Oscillator Circuit (Figure 1):

$$R_1 = R_2 = 12 \text{ k}\Omega$$

$$R_3 = 39 \Omega$$

$$R_4 = 1 \text{ M}\Omega$$

$$C_1 = 0.1 \mu F$$

$$C_2 = 0.01 \mu F$$

DC LED Circuit (Figure 10):

$$R_5 = 680 \Omega$$

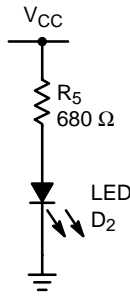

Figure 10. DC LED Circuit with Normalized Current Equal to the Pulsed LED Oscillator of Figure 1

The oscillation and LED current measurements are summarized in Table 1. Figure 11 shows the PCB that was created to verify the operation of the LED circuits. The error in the calculated versus measure oscillation frequency is a

result of the assumptions that $V_{OH} = V_{CC}$ and $V_{TH} = 0.5 \times V_{CC}$. In addition, the tolerance of the resistors and capacitors contributed to the frequency error. The pulsed LED is noticeably brighter than the DC LED; however, the LED's light output was not quantified with a light spectrometer.

Note that the maximum average current limit of the NL27WZ04 inverter is specified at 24 ma. The pulsed peak current exceeds the maximum limit; however, the current rating of the device is not exceeded because the average current is below the 24 ma limit. Although a maximum peak current limit is typically not specified for logic devices, a safe peak current can be verified by measuring the case temperature of the IC. If the temperature of the logic device is significantly higher than the ambient (i.e. 10–20°C), the reliability of the circuit maybe reduced. The case temperature of the NL27WZ04 inverter of the LED oscillator did not significantly increase.

Table 1. Experimental Results of the LED Oscillator

V _{CC}	Calculated Oscillation Frequency	Measured Oscillation Frequency	Measured Duty Cycle	Pulsed LED Peak Current	Pulsed LED Average (RMS) Current	DC LED Average Current
2.5 V	1.09 kHz	1.24 kHz	9.4%	9.79 mA	0.92 mA	0.98 mA
3.3 V	1.09 kHz	1.11 kHz	9.4%	21.3 mA	2.00 mA	2.06 mA
5.0 V	1.09 kHz	1.04 kHz	9.4%	46.7 mA	4.39 mA	4.45 mA

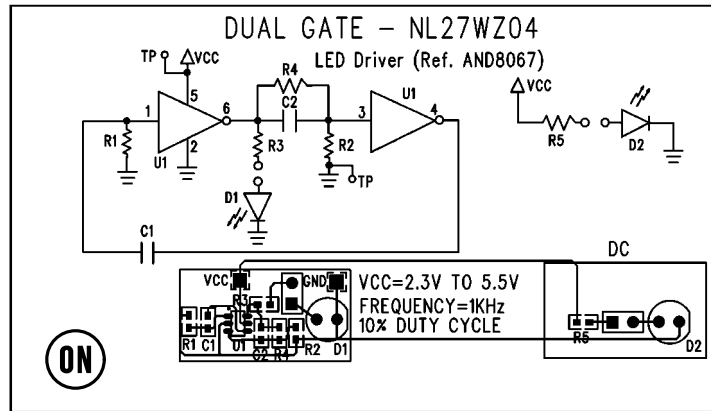



Figure 11. LED Oscillator Evaluation PCB

BIBLIOGRAPHY

1. “Application Note 1005: Operational Considerations for LED Lamps and Display Devices,” Agilent Technologies, 1999.
2. “Guidelines for Designs using LEDs: How to Enhance Display Performance without Increasing the Drive Current,” Fairchild Semiconductor, 1999.
3. HLMP–Pxxx, HLMP–Qxxx, HLMP–6xxx and HLMP–70xx Series Subminiature LED Lamps Datasheet, Agilent Technologies, 2000.
4. Smith, George, “Multiplexing LED Displays: Appnote 3,” Siemens Semiconductor.

Notes

Notes

ON Semiconductor and  are trademarks of Semiconductor Components Industries, LLC (SCILLC). SCILLC reserves the right to make changes without further notice to any products herein. SCILLC makes no warranty, representation or guarantee regarding the suitability of its products for any particular purpose, nor does SCILLC assume any liability arising out of the application or use of any product or circuit, and specifically disclaims any and all liability, including without limitation special, consequential or incidental damages. "Typical" parameters which may be provided in SCILLC data sheets and/or specifications can and do vary in different applications and actual performance may vary over time. All operating parameters, including "Typicals" must be validated for each customer application by customer's technical experts. SCILLC does not convey any license under its patent rights nor the rights of others. SCILLC products are not designed, intended, or authorized for use as components in systems intended for surgical implant into the body, or other applications intended to support or sustain life, or for any other application in which the failure of the SCILLC product could create a situation where personal injury or death may occur. Should Buyer purchase or use SCILLC products for any such unintended or unauthorized application, Buyer shall indemnify and hold SCILLC and its officers, employees, subsidiaries, affiliates, and distributors harmless against all claims, costs, damages, and expenses, and reasonable attorney fees arising out of, directly or indirectly, any claim of personal injury or death associated with such unintended or unauthorized use, even if such claim alleges that SCILLC was negligent regarding the design or manufacture of the part. SCILLC is an Equal Opportunity/Affirmative Action Employer.

PUBLICATION ORDERING INFORMATION

Literature Fulfillment:

Literature Distribution Center for ON Semiconductor
P.O. Box 5163, Denver, Colorado 80217 USA
Phone: 303-675-2175 or 800-344-3860 Toll Free USA/Canada
Fax: 303-675-2176 or 800-344-3867 Toll Free USA/Canada
Email: ONlit@hibbertco.com

N. American Technical Support: 800-282-9855 Toll Free USA/Canada

JAPAN: ON Semiconductor, Japan Customer Focus Center
4-32-1 Nishi-Gotanda, Shinagawa-ku, Tokyo, Japan 141-0031
Phone: 81-3-5740-2700
Email: r14525@onsemi.com

ON Semiconductor Website: <http://onsemi.com>

For additional information, please contact your local Sales Representative.