

## Flasher, 18-mΩ Shunt, Frequency Doubling Disabling

### Description

The design of the U6433B is similar to that of U6043B, both devices have the same excellent EMC (Electro Magnetic Capability) and protection features. The U6433B includes an additional 8-mV comparator and a logical connection with the frequency doubling stage. This combination can be used for a hazard switch which

bypasses the external shunt resistor to disable the frequency doubling. This feature is especially important with respect to the US automotive industry. During direction mode the U6433B works like other flashers, i.e., frequency doubling in the case of lamp outage.

### Features

- Temperature and voltage compensated frequency
- Warning indication of lamp failure by means of frequency doubling can be disabled
- Voltage dependence of the car indicator lamps compensated for lamp failure
- Relay output with high current carrying capacity
- Minimum lamp load for flasher operation  $\geq 1$  W
- Load-dump protection
- Very low susceptibility to EMI
- Protection according to ISO/TR 7637/1 level 4

### Ordering Information

Extended Type Number	Package	Remarks
U6433B-FP	SO8	

### Block Diagram

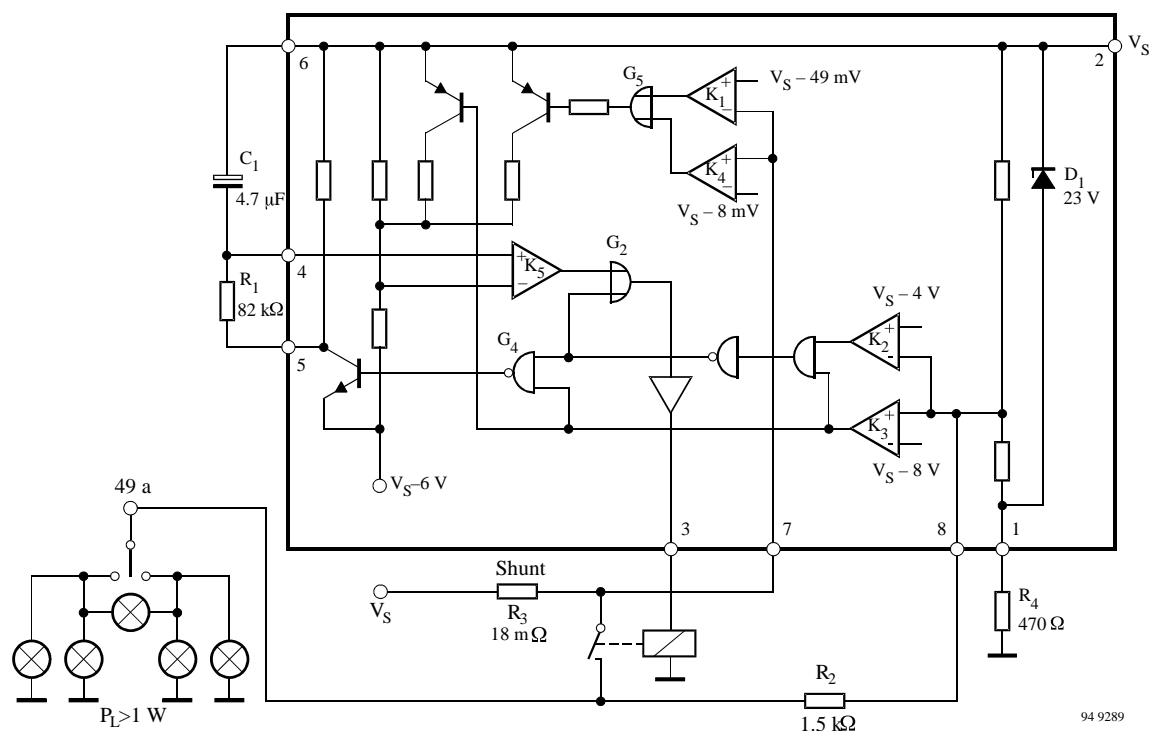
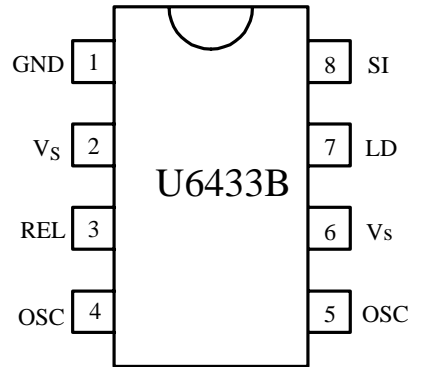

Figure 1. Application circuit as a car flasher

## Pin Description

Pin	Symbol	Function
1	GND	IC ground
2	V <sub>S</sub>	Supply voltage
3	REL	Relay driver
4	OSC	Oscillator
5	OSC	Oscillator
6	V <sub>S</sub>	Supply voltage
7	LD	Lamp failure detection
8	SI	Start input (49a)



13298

Figure 2. Pinning

## Functional Description

### Pin 1, GND

The integrated circuit is protected against damage via resistor R<sub>4</sub> to ground (-31) in the case of battery reversal. An integrated protection circuit together with external resistances R<sub>2</sub> and R<sub>4</sub> limits the current pulses in the IC.

### Pin 2, Supply voltage, V<sub>S</sub> - Power

The arrangement of the supply connections to Pin 2 must be so as to ensure that, on the connection printed circuit board (PCB), the resistance of V<sub>S</sub> to Pin 6 is lower than that to Pin 2.

### Pin 3, Relay control output (driver)

The relay control output is a high-side driver with a low saturation voltage and capable to drive a typical automotive relay with a minimum coil resistance of 60 Ω.

### Pin 4 and 5 Oscillator

Flashing frequency, f<sub>1</sub>, is determined by the R<sub>1</sub>C<sub>1</sub> components as follows (see figure 1):

$$f_1 \approx \frac{1}{R_1 \times C_1 \times 1.5} \text{ Hz}$$

where  $C_1 \leq 47 \mu\text{F}$   
 $R_1 = 6.8 \text{ k}\Omega \text{ to } 510 \text{ k}\Omega$

In the case of a lamp outage (see Pin 7) the oscillator frequency is switched to the lamp outage frequency f<sub>2</sub> with f<sub>2</sub> ≈ 2.2 f<sub>1</sub>.

Duty cycle in normal flashing mode: 50%  
 Duty cycle in lamp outage mode: 40% (bright phase)

### Pin 6, Supply voltage, Sense

For accurate monitoring via the shunt resistor, a minimized layer resistance from point V<sub>S</sub> / shunt to Pin 6 is recommended.

### Pin 7, Lamp outage detection

#### Control Signal Threshold 1 (49-mV Comparator K1)

The detection point for lamp failure can be calculated from the control signal threshold, typically 49 mV with V<sub>S</sub> = 12 V. With a measuring resistance of R<sub>3</sub> = 18 mΩ, the frequency change-over is reached at a lamp load of 21 W + 11.4 W. The variation of the control signal threshold supply voltage takes into account the PTC characteristic of filament lamps.

#### Control Signal Threshold 2 (8-mV Comparator K4)

A voltage drop at R<sub>3</sub> between 49 mV and 8 mV shunt resistor lets the flasher work in frequency doubling mode.

If the voltage drop decreases to a value below V<sub>R3MAX</sub> = 8 mV, frequency doubling is disabled. This can be achieved either with a switch which by-passes the shunt resistor (e.g., a special hazard warning switch) or with a small lamp load.

The arrangement of the supply connections to Pins 2 and 6 must ensure that, on the connection, PCB, the layer resistance from V<sub>S</sub> to Pin 6 is lower than the one to Pin 2.

Flasher operation starts with a lamp load of P<sub>L</sub> ≥ 1 W.

### Pin 8, Start input

Start condition for flashing: the voltage at Pin 8 has to be below K3 threshold (flasher switch closed).

Humidity and dirt may decrease the resistance between 49 a and GND. If this leakage resistance is > 5 kΩ the IC is still kept in its off-condition. In this case the voltage at Pin 8 is between the thresholds of comparators K2 and K3.

During the bright phase the voltage at Pin 8 is above the K2 threshold, during the dark phase it is below the K3 threshold.

For proper start conditions a minimum lamp wattage of 1 W is required.

## Absolute Maximum Ratings

Reference point Pin 1

Parameters	Symbol	Value	Unit
Supply voltage Pins 2 and 6	$V_S$	18	V
Surge forward current $t_p = 0.1$ ms Pins 2 and 6	$I_{FSM}$	1.5	A
$t_p = 300$ ms Pins 2 and 6		1.0	A
$t_p = 300$ ms Pin 8		30.0	mA
Output current Pin 3	$I_O$	0.3	A
Power dissipation $T_{amb} = 95^\circ\text{C}$ SO 8	$P_{tot}$	340	mW
$T_{amb} = 60^\circ\text{C}$ SO 8		560	mW
Junction temperature	$T_j$	150	$^\circ\text{C}$
Ambient temperature range	$T_{amb}$	-40 to +105	$^\circ\text{C}$
Storage temperature range	$T_{stg}$	-55 to +150	$^\circ\text{C}$

## Thermal Resistance

Parameters	Symbol	Value	Unit
Junction ambient SO8	$R_{thJA}$	160	K/W

## Electrical Characteristics

Typical values under normal operation of the application circuit shown in figure 1,  $V_S = 12$  V (Pins 2 and 6).  
 $T_{amb} = 25^\circ\text{C}$ , reference point ground (-31), unless otherwise specified.

Parameters	Test conditions / Pin	Symbol	Min.	Typ.	Max.	Unit
Supply voltage range	Pins 2 and 6	$V_S$	9		16.5	V
Supply current, dark phase	Pins 2 and 6	$I_S$		4.5	8	mA
Supply current, bright phase	Pins 2 and 6	$I_S$		7.0	11	mA
Relay output, saturation voltage	$I_O = 150$ mA, $V_S = 9$ V Pin 3	$V_O$			1.0	V
Relay output reverse current	Pin 3	$I_O$			0.1	mA
Relay coil resistance		$R_L$	60			$\Omega$
Start delay	First bright phase	$t_{on}$			10	ms
Frequency determining resistor		$R_1$	6.8		510	k $\Omega$
Frequency determining capacitor		$C_1$			47	$\mu\text{F}$
Frequency tolerance	Normal flashing, basic frequency $f_1$ not including the tolerances of the external components $R_1$ and $C_1$	$\Delta f_1$	-5		+5	%
Bright period	Basic frequency $f_1$ , $V_S = 9 - 15$ V	$\Delta f_1$	47		53	%
Bright period	Control frequency $f_2$ , $V_S = 9 - 15$ V	$\Delta f_2$	37		45	%
Frequency increase	Lamp failure, $V_S = 9 - 15$ V	$f_2$	$2.15 \times f_1$		$2.3 \times f_1$	Hz

## Electrical Characteristics (continued)

Parameters	Test conditions / Pin	Symbol	Min.	Typ.	Max.	Unit
Control signal threshold 1	$V_S = 15\text{ V}$ Pin 7	$V_{R3}$	50	53	57	mV
	$V_S = 9\text{ V}$		43	45	47	
	$V_S = 12\text{ V}$		47	49	51	
Control signal threshold 2		$V_{R3}$	2		10	mV
Leakage resistance	49a to GND	$R_p$			5	k $\Omega$
Lamp load		$P_L$	1			W

## Package Information

Package SO8

Dimensions in mm

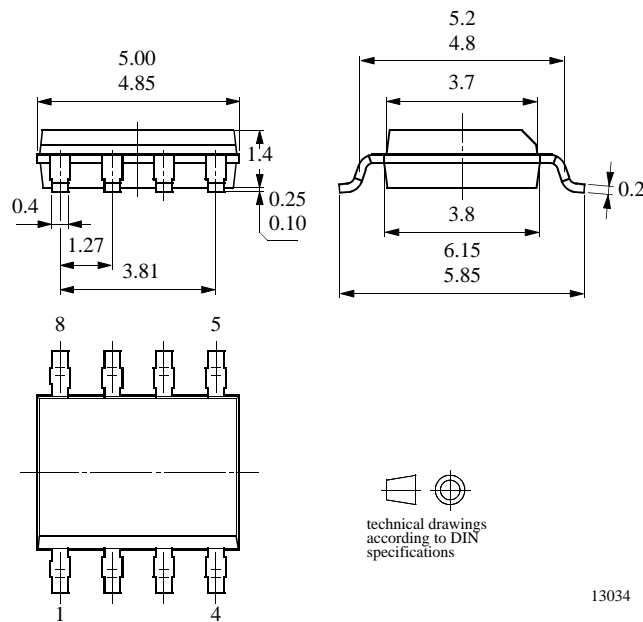

---

## Ozone Depleting Substances Policy Statement

It is the policy of **TEMIC Semiconductor GmbH** to

1. Meet all present and future national and international statutory requirements.
2. Regularly and continuously improve the performance of our products, processes, distribution and operating systems with respect to their impact on the health and safety of our employees and the public, as well as their impact on the environment.

It is particular concern to control or eliminate releases of those substances into the atmosphere which are known as ozone depleting substances (ODSs).

The Montreal Protocol (1987) and its London Amendments (1990) intend to severely restrict the use of ODSs and forbid their use within the next ten years. Various national and international initiatives are pressing for an earlier ban on these substances.

**TEMIC Semiconductor GmbH** has been able to use its policy of continuous improvements to eliminate the use of ODSs listed in the following documents.

1. Annex A, B and list of transitional substances of the Montreal Protocol and the London Amendments respectively
2. Class I and II ozone depleting substances in the Clean Air Act Amendments of 1990 by the Environmental Protection Agency (EPA) in the USA
3. Council Decision 88/540/EEC and 91/690/EEC Annex A, B and C (transitional substances) respectively.

**TEMIC Semiconductor GmbH** can certify that our semiconductors are not manufactured with ozone depleting substances and do not contain such substances.

**We reserve the right to make changes to improve technical design and may do so without further notice.**

Parameters can vary in different applications. All operating parameters must be validated for each customer application by the customer. Should the buyer use TEMIC Semiconductors products for any unintended or unauthorized application, the buyer shall indemnify TEMIC Semiconductors against all claims, costs, damages, and expenses, arising out of, directly or indirectly, any claim of personal damage, injury or death associated with such unintended or unauthorized use.

TEMIC Semiconductor GmbH, P.O.B. 3535, D-74025 Heilbronn, Germany  
Telephone: 49 (0)7131 67 2594, Fax number: 49 (0)7131 67 2423