

# FLC257MH-6

## C-Band Power GaAs FET

### FEATURES

- High Output Power:  $P_{1dB} = 34.0dBm(Typ.)$
- High Gain:  $G_{1dB} = 9.0dB(Typ.)$
- High PAE:  $\eta_{add} = 36\%(Typ.)$
- Proven Reliability
- Hermetic Metal/Ceramic Package

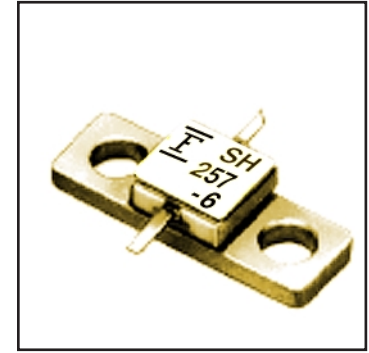

### DESCRIPTION

The FLC257MH-6 is a power GaAs FET that is designed for general purpose applications in the C-Band frequency range as it provides superior power, gain, and efficiency.

Fujitsu's stringent Quality Assurance Program assures the highest reliability and consistent performance.

### ABSOLUTE MAXIMUM RATING (Ambient Temperature $T_a=25^\circ C$ )

Item	Symbol	Condition	Rating	Unit
Drain-Source Voltage	$V_{DS}$		15	V
Gate-Source Voltage	$V_{GS}$		-5	V
Total Power Dissipation	$P_T$	$T_C = 25^\circ C$	15	W
Storage Temperature	$T_{stg}$		-65 to +175	$^\circ C$
Channel Temperature	$T_{ch}$		175	$^\circ C$

Fujitsu recommends the following conditions for the reliable operation of GaAs FETs:

1. The drain-source operating voltage ( $V_{DS}$ ) should not exceed 10 volts.
2. The forward and reverse gate currents should not exceed 17.8 and -1.2 mA respectively with gate resistance of  $200\Omega$ .
3. The operating channel temperature ( $T_{ch}$ ) should not exceed  $145^\circ C$ .

### ELECTRICAL CHARACTERISTICS (Ambient Temperature $T_a=25^\circ C$ )

Item	Symbol	Test Conditions	Limit			Unit
			Min.	Typ.	Max.	
Saturated Drain Current	$I_{DSS}$	$V_{DS} = 5V, V_{GS} = 0V$	-	1000	1500	mA
Transconductance	$g_m$	$V_{DS} = 5V, I_{DS} = 600mA$	-	500	-	mS
Pinch-off Voltage	$V_p$	$V_{DS} = 5V, I_{DS} = 50mA$	-1.0	-2.0	-3.5	V
Gate Source Breakdown Voltage	$V_{GSO}$	$I_{GS} = -50\mu A$	-5	-	-	V
Output Power at 1dB G.C.P.	$P_{1dB}$	$V_{DS} = 10V,$ $I_{DS} = 0.6 I_{DSS} (Typ.),$ $f = 6.4 GHz$	32.5	34.0	-	dBm
Power Gain at 1dB G.C.P.	$G_{1dB}$		8.0	9.0	-	dB
Power-added Efficiency	$\eta_{add}$		-	36	-	%
Thermal Resistance	$R_{th}$	Channel to Case	-	8	10	$^\circ C/W$

CASE STYLE: MH

G.C.P.: Gain Compression Point

# FLC257MH-6

## C-Band Power GaAs FET

**POWER DERATING CURVE**

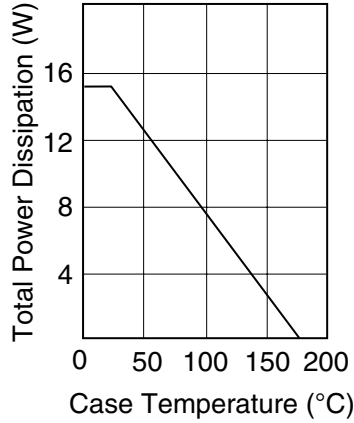

**DRAIN CURRENT vs. DRAIN-SOURCE VOLTAGE**

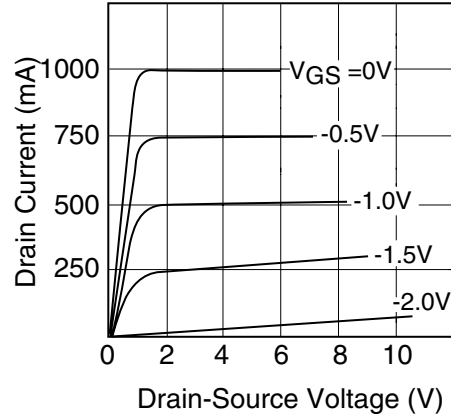

**OUTPUT POWER & IM<sub>3</sub> vs. INPUT POWER**

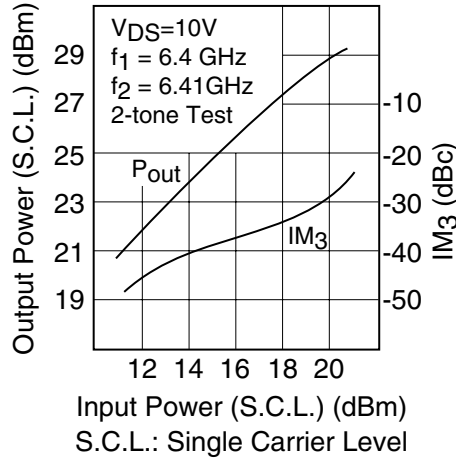

**OUTPUT POWER vs. INPUT POWER**

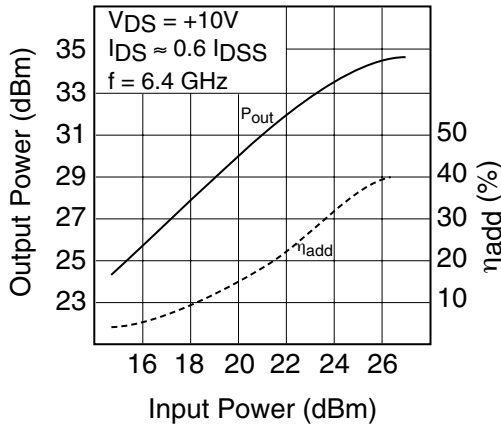

**P<sub>1dB</sub> & η<sub>add</sub> vs. V<sub>DS</sub>**

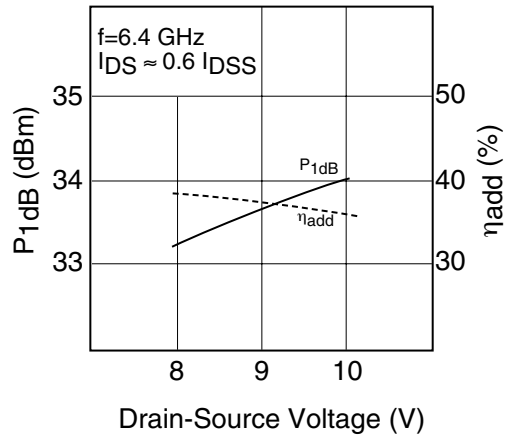

# FLC257MH-6

## C-Band Power GaAs FET

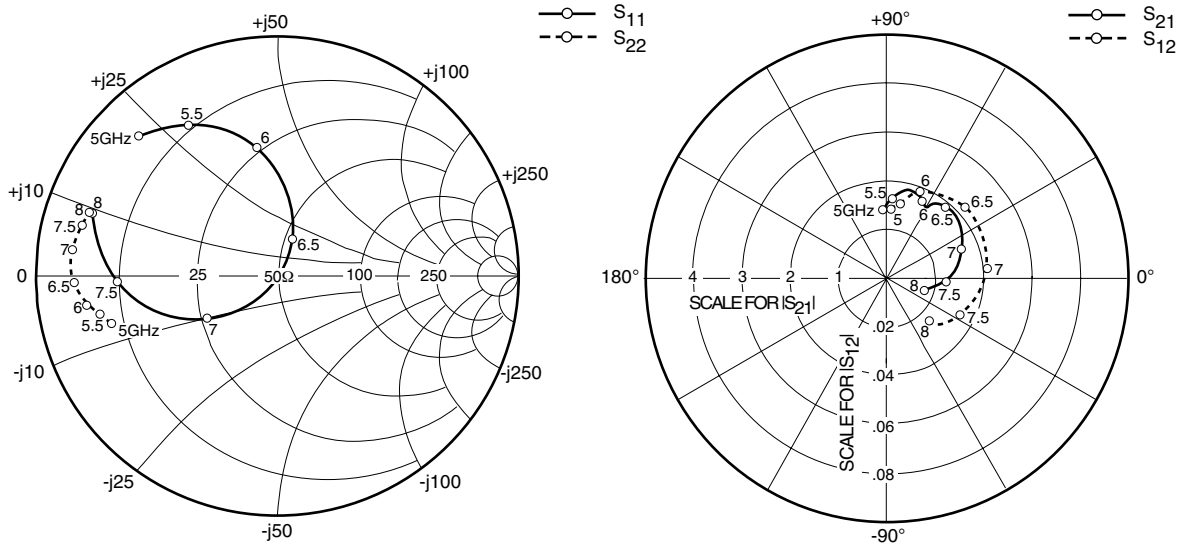

### S-PARAMETERS

$V_{DS} = 10V, I_{DS} = 600mA$

FREQUENCY (MHZ)	S11		S21		S12		S22	
	MAG	ANG	MAG	ANG	MAG	ANG	MAG	ANG
500	.937	-142.8	7.241	109.5	.020	30.3	.351	-157.1
5000	.818	134.9	1.418	91.8	.029	86.1	.719	-163.9
5500	.729	120.3	1.596	85.8	.031	79.7	.751	-167.5
6000	.542	99.1	1.737	64.9	.038	69.2	.800	-170.6
6500	.166	67.8	1.912	50.3	.044	41.5	.839	-178.0
7000	.338	-148.2	1.664	20.5	.042	5.6	.856	172.9
7500	.667	-177.6	1.231	-1.8	.034	-25.6	.832	165.7
8000	.814	161.6	.810	-16.0	.025	-44.4	.825	160.9

# FLC257MH-6

## C-Band Power GaAs FET

### Case Style "MH" Metal-Ceramic Hermetic Package

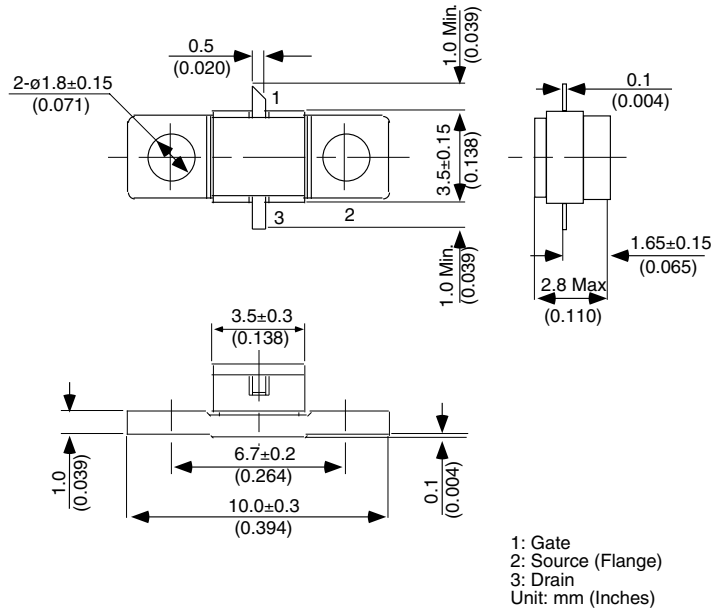

For further information please contact:

#### FUJITSU COMPOUND SEMICONDUCTOR, INC.

2355 Zanker Rd.

San Jose, CA 95131-1138, U.S.A.

Phone: (408) 232-9500

FAX: (408) 428-9111

www.fcsi.fujitsu.com

#### FUJITSU MICROELECTRONICS, LTD.

Compound Semiconductor Division

Network House

Norreys Drive

Maidenhead, Berkshire SL6 4FJ

Phone: +44 (0)1628 504800

FAX: +44 (0)1628 504888

#### CAUTION

Fujitsu Compound Semiconductor Products contain **gallium arsenide (GaAs)** which can be hazardous to the human body and the environment. For safety, observe the following procedures:

- Do not put these products into the mouth.
- Do not alter the form of this product into a gas, powder, or liquid through burning, crushing, or chemical processing as these by-products are dangerous to the human body if inhaled, ingested, or swallowed.
- Observe government laws and company regulations when discarding this product. This product must be discarded in accordance with methods specified by applicable hazardous waste procedures.

Fujitsu Limited reserves the right to change products and specifications without notice. The information does not convey any license under rights of Fujitsu Limited or others.

© 1998 FUJITSU COMPOUND SEMICONDUCTOR, INC.

Printed in U.S.A. FCSI0598M200

# FUJITSU