

EDE1200 Unipolar Stepper Motor IC

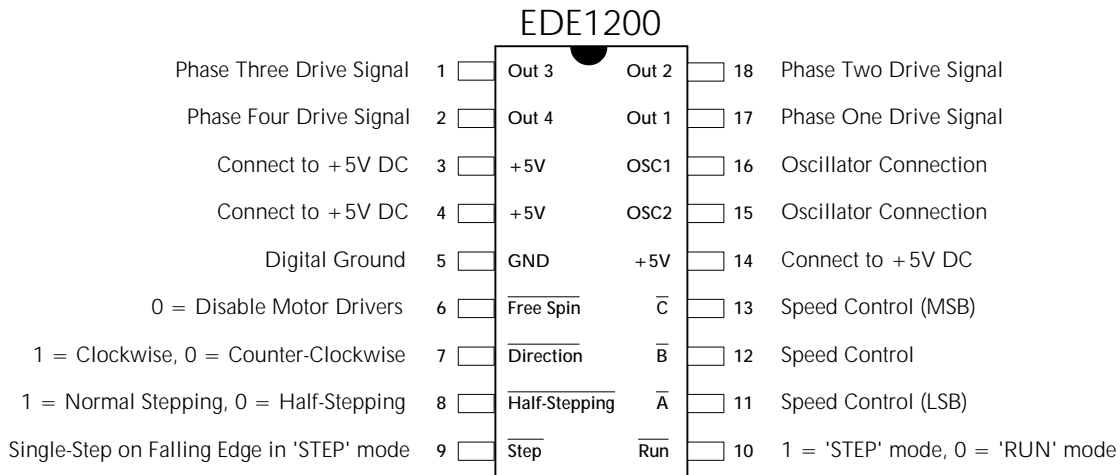

The EDE1200 Unipolar Stepper Motor IC is a 5 volt, 18 pin package designed to interface a logic-level input byte to a stepper motor. The EDE1200 is capable of self-clocking in the free-standing 'RUN' mode, as well as external clocking in the 'STEP' mode. In addition, half-stepping and directional control are also available. The TTL-level outputs sequence the stepper drive circuits that consist of standard power transistors or a transistor array IC. The EDE1200 features the ability to change the stepping rate while the motor is stepping and to take an unlimited number of steps in continuous 'RUN' mode. Inputs are TTL/ CMOS compatible.

RUN mode

In the 'RUN' mode, activated by a low on pin 10, the EDE1200 will cause the motor to rotate according to the following parameters:

Direction (pin 7): 1 = clockwise, 0 = counter-clockwise
(If a clockwise command causes counterclockwise rotation of motor, reverse the sequence of the motor's four phase wires.)

Half-Stepping (pin 8): 1 = normal stepping, 0 = half stepping (doubles step resolution)

Speed Control [C,B,A] (pins 13,12,11): these three active-low bits select one of eight rotational speeds. Refer to Tables One & Two below for speed range details.

Table One - Full Step 'RUN' mode speeds*:

Revolutions per second & minute are based upon a 1.8 ° per step motor.
EDE1200 external clock speed is 4 MHz.

Speed Input (C,B,A)	RPS	RPM
000	.152	9.1
001	.172	10.3
010	.2	12
011	.244	14.6
100	.303	18.2
101	.4	24
110	.606	36.4
111	1.18	70.6

Table Two - Half-Step 'RUN' mode speeds*:

Revolutions per second & minute are based upon a 1.8 ° per step motor.
EDE1200 external clock speed is 4 MHz.

Speed Input (C,B,A)	RPS	RPM
000	.077	4.6
001	.089	5.3
010	.103	6.2
011	.121	7.27
100	.154	9.2
101	.2	12
110	.303	18.2
111	.606	36.4

* NOTE: indicated speeds are approximate and may vary with oscillator frequency and other factors. Please verify exact value before using in any speed-critical application.

The following chart depicts revolutions per second for a 1.8 ° stepper motor in relation to the three speed selection bits for both full and half stepping. Please note that the speed increase is nonlinear; i.e. finer speed control is available at slower step speeds. Again, indicated speeds are approximate and may vary with oscillator frequency. Please verify exact value before using in any speed-critical application.

Motor Speed vs. Speed Selection Bits

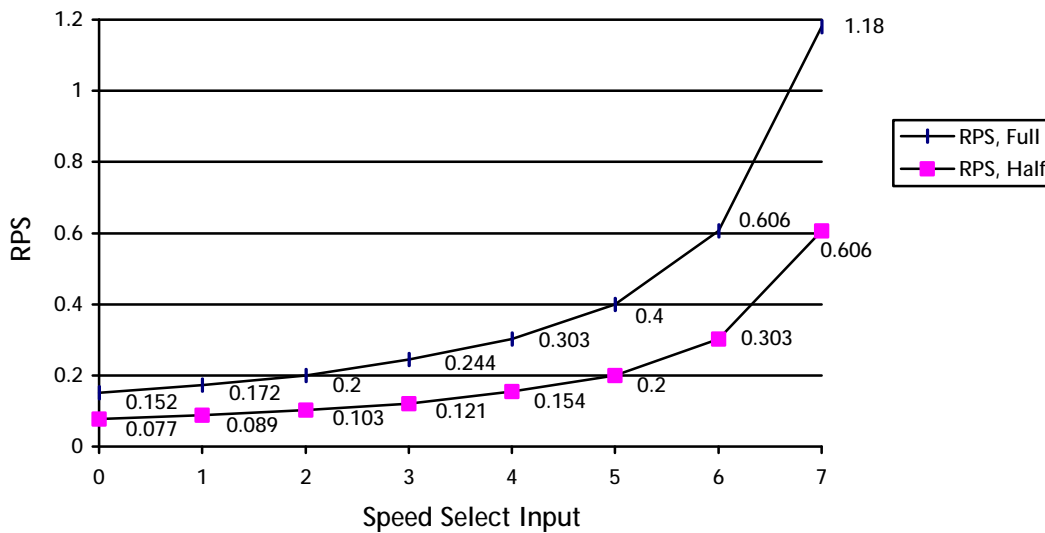

STEP mode

In the 'STEP' mode, an external clock signal is required for each step of the motor. The RUN (pin 10) line must be left high. Each low-going pulse on the STEP (pin 9) line causes a movement of the motor according to the Direction and Half-step pins as specified below:

Direction (pin 7): 1 = clockwise, 0 = counter-clockwise
(If a clockwise command causes counterclockwise rotation of motor, reverse the sequence of the motor's four phase wires.)

Half-Stepping (pin 8): 1 = normal stepping, 0 = half stepping (doubles step resolution)

With the EDE1200 running at an external clock speed of 4 MHz, the 'STEP' pin may be driven at speeds up to 5 KHz, resulting in a motor speed over 1,500 RPM with a 1.8° per step motor. All stepper motors require ramped acceleration to such high RPM rates; do not instantly apply high speed step requests immediately to a stopped motor. Motor type and load will determine maximum acceleration rate. However, ordinary speed ranges (such as the EDE1200's 'RUN' mode speeds) do not require a ramped acceleration.

Free-Spin

Holding the free-spin input (pin 6) low causes the EDE1200 to de-activate all motor coils. During ordinary operation (step and run modes) the motor is held in position by the 'braking' effect inherent in all stepper motors. Activating this active-low input allows the motor spindle to spin freely without the braking effect. Braking effect is resumed when free-spin input (pin 6) is raised.

Application Examples

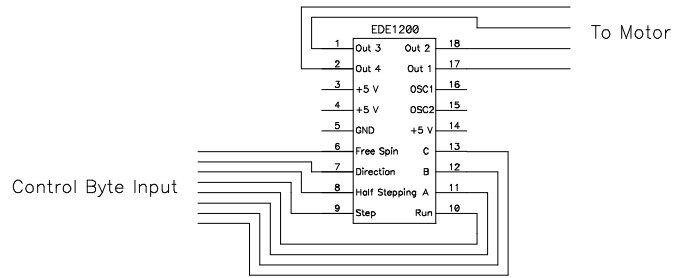

Basic Usage Diagram (without power & oscillator connections)

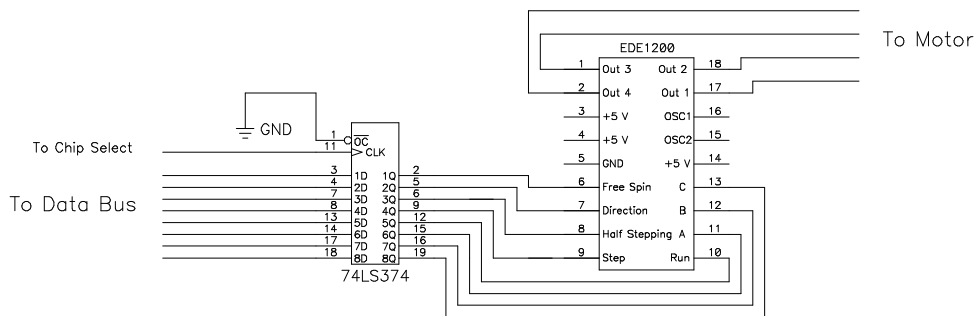

Interfacing to a Microprocessor/ Microcontroller

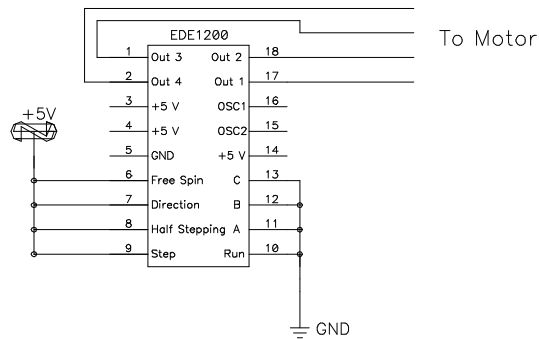

Free Running Mode Example Setup

Hookup Diagrams

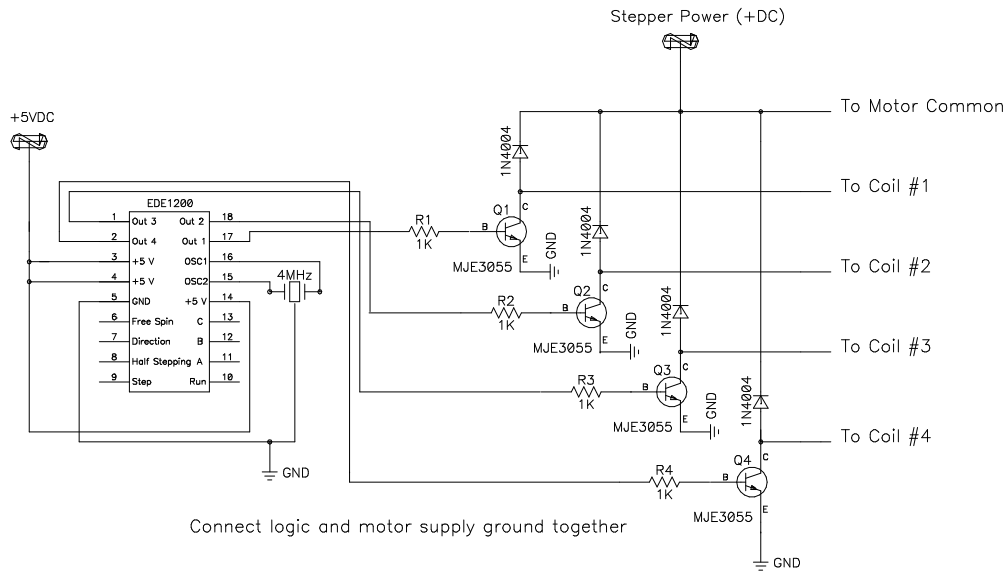

Implementation via Four MJE3055 Transistors

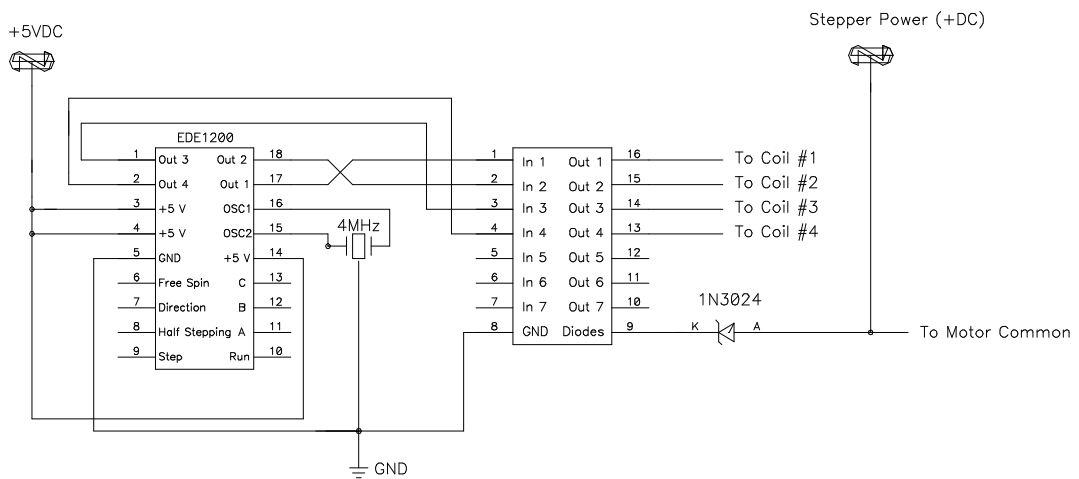

Implementation via ULN2003A IC

ABSOLUTE MAXIMUM RATINGS

Oscillator frequency	4 MHz
Supply Voltage	7.5V
Ambient temperature under bias	-55°C to +125°C
Max. current into input pin	±500µA
Max. current sunk by output pin	25mA
Max. current sourced by output pin	20mA
Max. current sourced by all 4 outputs.....	50mA
Max. current sunk by all four outputs.....	50mA

STANDARD OPERATING CONDITIONS

Supply voltage	3.0V to 5.5V
Operating temperature	0°C to +70°C

IMPORTANT NOTICE

E-LAB Digital Engineering, Inc. (E-LAB), reserves the right to change products or specifications without notice. Customers are advised to obtain the latest versions of product specifications, which should be considered when evaluating a product's appropriateness for a particular use.

THIS PRODUCT IS WARRANTED TO COMPLY WITH E-LAB'S SPECIFICATION SHEET AT THE TIME OF DELIVERY. BY USING THIS PRODUCT, CUSTOMER AGREES THAT IN NO EVENT SHALL E-LAB BE LIABLE FOR ANY DIRECT, INDIRECT, SPECIAL, INCIDENTAL OR CONSEQUENTIAL DAMAGES AS A RESULT OF THE PERFORMANCE, OR FAILURE TO PERFORM, OF THIS PRODUCT.

E-LAB MAKES NO OTHER WARRANTIES, EXPRESSED OR IMPLIED, INCLUDING ANY IMPLIED WARRANTIES OF MERCHANTABILITY OR FITNESS FOR A PARTICULAR PURPOSE.

E-LAB'S LIABILITY IS FOR A PERIOD NO GREATER THAN 90 DAYS FROM DATE OF SHIPMENT BY E-LAB AND IS LIMITED TO REPLACEMENT OF DEFECTIVE PRODUCT. This warranty covers only defects arising under normal use and not malfunctions resulting from misuse, abuse, modification, or repairs by anyone other than E-LAB.

E-LAB'S PRODUCTS ARE NOT AUTHORIZED FOR USE AS CRITICAL COMPONENTS IN LIFE SUPPORT DEVICES OR SYSTEMS WITHOUT THE EXPRESS WRITTEN APPROVAL OF THE PRESIDENT OF E-LAB. Life support devices or systems are those which are intended to support or sustain life and whose failure to perform can be reasonably expected to result in a significant injury or death to the user. Critical components are those whose failure to perform can be reasonably expected to cause failure of a life support device or system or affect its safety or effectiveness.

COPYRIGHT NOTICE

This product may not be duplicated. E-LAB Digital Engineering, Inc. holds all copyrights on firmware, with all rights reserved. Unauthorized duplication of this device may be subject to penalty under state and/ or federal law.

EDE1200 and the E-LAB logo are trademarks of E-LAB Digital Engineering, Inc.

CONTACTING US

E-LAB Digital Engineering, Inc.
Carefree Industrial Park
1600 N. State Rte. 291 Hwy. Ste. 330
Independence, MO 64052-0436

Telephone: (816) 257-9954
FAX: (816) 257-9945

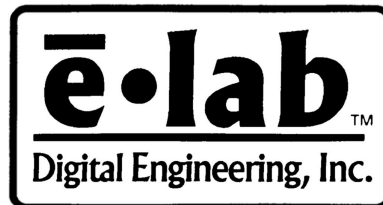

www.elabinc.com
support@elabinc.com