

100BASE-T MII-to-PMD Transceiver

GENERAL DESCRIPTION

The ML6691 implements the upper portion of the physical layer for the Fast Ethernet 100BASE-T standard. Functions contained in the ML6691 include a 4B/5B encoder/decoder, a Stream Cipher scrambler/descrambler, and collision detect. Additional functions of the ML6691 — accessible through the two-wire MII management interface — include full duplex operation, loopback, power down mode, and MII isolation.

The ML6691 is designed to interface to a 100BASE-T Ethernet Media Access Controller (MAC) via the MII (Media Independent Interface) on one side, and a 100BASE-X PMD transceiver on the other side. A complete 100BASE-TX physical layer (PHY) solution is realized using the ML6691, the ML6673, and one of the available clock recovery/generation devices. A 100BASE-FX physical layer solution is implemented by disabling the scrambler function of the ML6691 and using an external optical PMD.

FEATURES

- Conforms to the Fast Ethernet 100BASE-T IEEE 802.3 μ standard
- Integrated 4B/5B encoder/decoder
- Integrated Stream Cipher scrambler/descrambler
- Compliant MII interface
- Two-wire serial interface management port for configuration and control
- On-chip 25 MHz crystal oscillator
- Interfaces to either AMD's PDT/PDR (AM79865/79866) or Motorola's FCG (MC68836)
- Used with ML6673 for 100BASE-TX solutions
- 44-pin PLCC package

* This Part Is End Of Life As Of August 1, 2000

BLOCK DIAGRAM

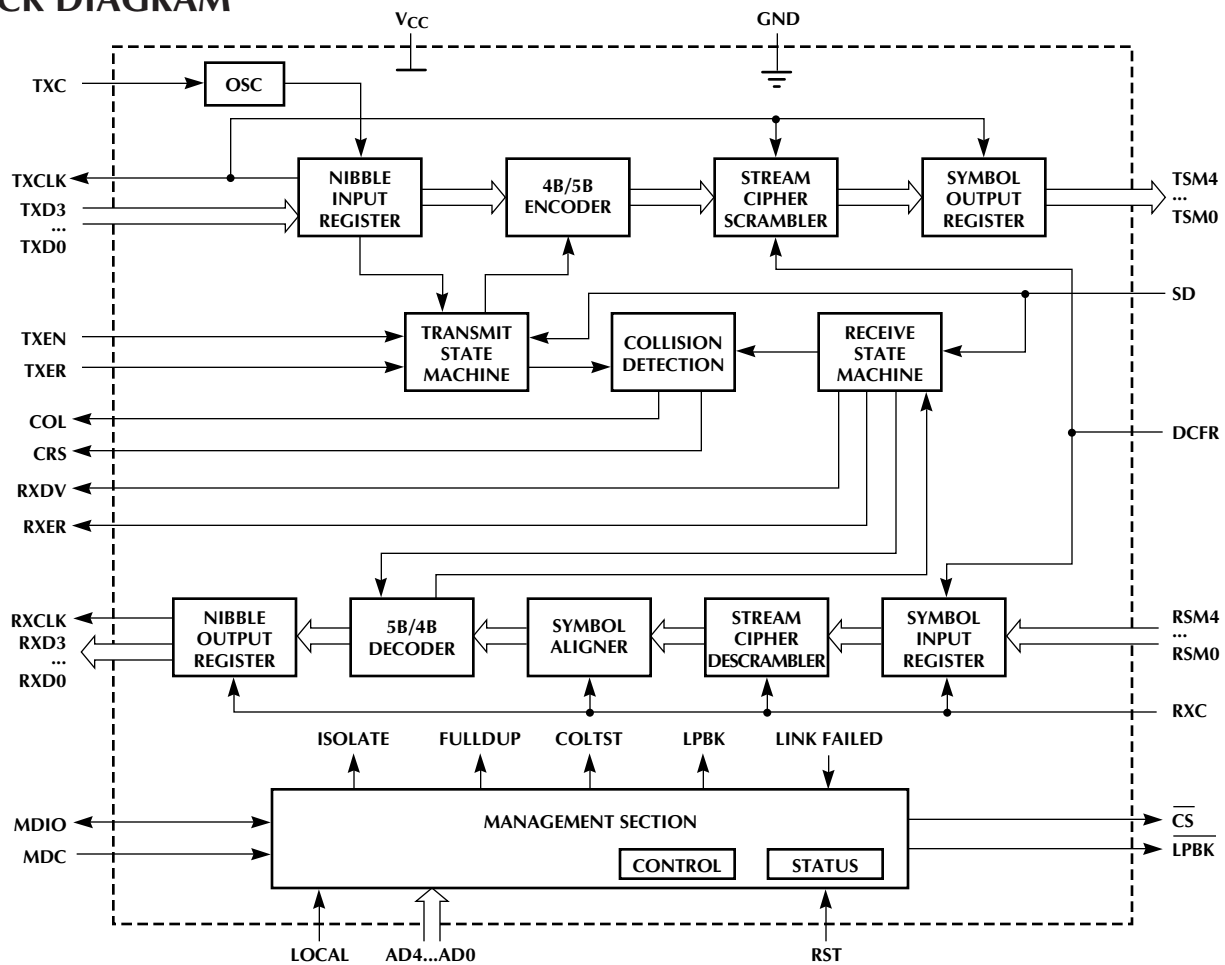

PIN CONFIGURATION

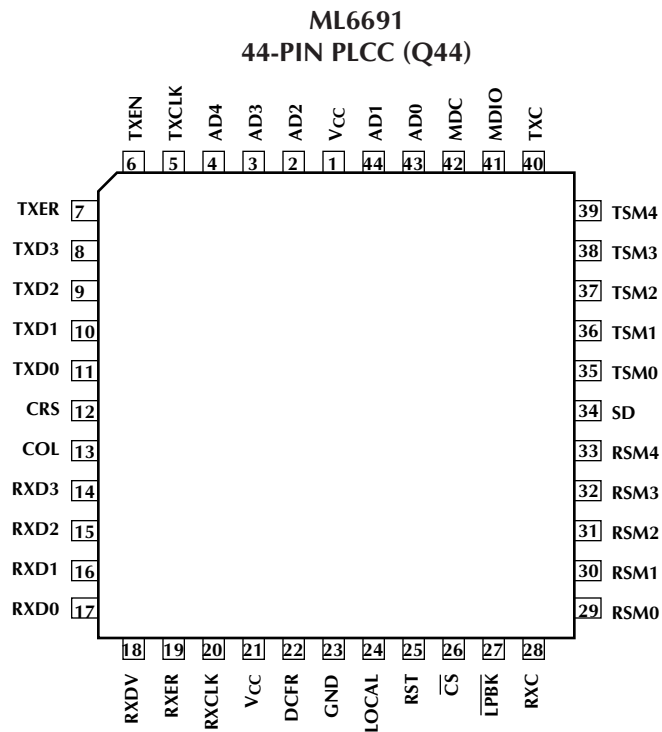

PIN DESCRIPTION

PIN#	NAME	FUNCTION	PIN#	NAME	FUNCTION
1,21	V _{CC}	Positive 5 volt supply.	12	CRS	Carrier sense output. A logic high indicates that either the transmit or receive medium is non-idle. CRS is deasserted when both transmit and receive are idle.
2,3,4,43,44	AD[4:0]	Local PHY address. These 5 inputs set the address to which the local physical layer responds. When an address match is detected, the <u>CS</u> output is asserted.	13	COL	Collision detect output. A logic high indicates a collision (simultaneous transmit and receive in half duplex mode).
5	TXCLK	Transmit clock output. Continuous 25MHz clock provides the timing reference for the transfer of TXEN, TXER, and TXD[3:0] from the MAC. TXCLK is generated from the TXC input.	14-17	RXD[3:0]	Receive nibble data outputs. Nibble-wide data for transmission to the MAC. RXD[0] is the least significant bit. RXD[3:0] is synchronous to RXCLK.
6	TXEN	Transmit enable input. A logic high enables the transmit section of the ML6691. This signal indicates the MAC is transmitting nibble-wide data. TXEN is synchronous to TXCLK.	18	RXDV	Receive data valid output. A logic high indicates the ML6691 is presenting valid nibble-wide data. RXDV shall remain asserted from the first recovered nibble of the frame through the final recovered nibble. RXDV will be de-asserted prior to the first RXCLK that follows the final nibble. RXDV is synchronous to RXCLK.
7	TXER	Transmit error input. When TXER is high, while TXEN is asserted, the ML6691 will insert an "H" symbol in the data stream. TXER is synchronous to TXCLK.	19	RXER	Receive error output. Active high, indicates that a coding error was detected. RXER is synchronous to RXCLK.
8-11	TXD[3:0]	Transmit nibble data inputs. Nibble-wide data from the MAC. For data transmission TXEN must be asserted. TXD[0] is the least significant bit. TXD[3:0] is synchronous to TXCLK.			

PIN DESCRIPTION (Continued)

PIN#	NAME	FUNCTION	PIN#	NAME	FUNCTION
20	RXCLK	Receive clock output. Continuous 25 MHz clock provides the timing reference for the transfer of RXDV, RXER, and RXD[3:0] to the MAC.	29-33	RSM[4:0]	Receive symbol data inputs. Symbol-wide (encoded) data from the PMD layer.
22	DCFR	Scrambler/descrambler disable. A logic high on this input disables the Stream Cipher scrambler/descrambler.	34	SD	Signal detect. A logic high on this input indicates the presence of non-quiet data. The internal signal, linkfail, is enabled 330µs after SD is asserted.
23	GND	Ground	35-39	TSM[4:0]	Transmit symbol data outputs. Symbol-wide (encoded) data for transfer to the PMD layer.
24	LOCAL	Local/remote. A logic low on this input places the ML6691 in remote mode, in which the MII interface is disabled at power on or after a reset operation. When low, the isolate bit of the Control register will be set upon power up or reset.	40	TXC	Transmit symbol clock input. Input used to generate TXCLK. Use either a 25 MHz crystal or a 25 MHz clock between TXC input and GND.
25	RST	Reset. A logic high on this input resets the Status and Control registers to their default states.	41	MDIO	Management data input/output. A bi-directional signal used to transfer control and status information between the ML6691 and the MAC. MDIO is synchronous to MDC.
26	<u>CS</u>	Chip select. A logic low is generated on this output when the ML6691 detects an address match.	42	MDC	Management data clock input. A low-frequency aperiodic clock used as the timing reference for transfer of information on the MDIO signal.
27	<u>LPBK</u>	Loopback. A logic low on this output indicates the loopback function.			
28	RXC	Receive symbol clock. A 25 MHz clock input from the PMD layer. The rising edge of RXC is used to sample RSM[4:0].			

ABSOLUTE MAXIMUM RATINGS

Absolute maximum ratings are those values beyond which the device could be permanently damaged. Absolute maximum ratings are stress ratings only and functional device operation is not implied.

Supply Voltage (V_{CC}) 6.0V
 GND $-0.3V$ to $V_{CC} + 0.3V$
 Logic Inputs $-0.3V$ to $V_{CC} + 0.3V$
 Input Current per Pin $\pm 25mA$
 Storage Temperature $-65^{\circ}C$ to $+150^{\circ}C$
 Package Dissipation at $T_A = 25^{\circ}C$ 750mW
 Lead Temperature (soldering 10 sec.) $300^{\circ}C$

OPERATING CONDITIONS

Supply Voltage (V_{CC}) 4.5V to 5.5V
 Temperature Range $0^{\circ}C < T_A < 70^{\circ}C$

ELECTRICAL CHARACTERISTICS

Unless otherwise specified, $V_{CC} = 5V \pm 10\%$, $C_L = 15pF$, $T_A = T_{MIN}$ to T_{MAX}

PARAMETER	SYMBOL	CONDITIONS	MIN	TYP	MAX	UNITS
DC Characteristics						
Logic Input Low	V_{IL}	All except TXC TXC			0.8 1.5	V
Logic Input High	V_{IH}	All except TXC TXC	2.0 3.5			V
Logic Input Low Current	I_{IL}	$V_{IN} = 0$, all except TXC $V_{IN} = 0$, TXC	-10 -100			μA
Logic Input High Current	I_{IH}	$V_{IN} = V_{CC}$, all except TXC $V_{IN} = V_{CC}$, TXC			10 100	μA
Logic Output Low	V_{OL}	$I_{OL} = -4mA$			0.4	V
Logic Output High	V_{OH}	$I_{OH} = 4mA$	2.4			V
Input Capacitance	C_{IN}	All except TXC TXC			8 12	pF
AC Characteristics						
TXD Setup Time	t_1		15			ns
TXD Hold Time	t_2		0			ns
TXC to TSM Delay	t_3		5		25	ns
RSM Setup Time	t_4		10			ns
RSM Hold Time	t_5		5			ns
RXCLK to RXD Delay	t_6		0		10	ns
MDIO Setup Time	t_7		10			ns
MDIO Hold time	t_8		10			ns
MDC to MDIO Delay	t_9		0		300	ns

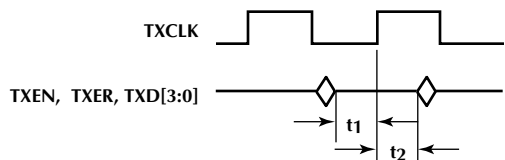

Transmit Timing Relationships (MII Interface)

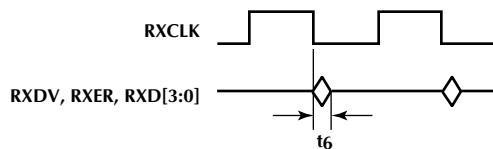

Receive Timing Relationships (MII Interface)

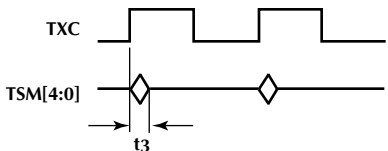

Transmit Timing Relationships (Physical Interface)

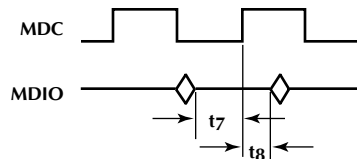

Management Timing Relations (Sourced by STA)

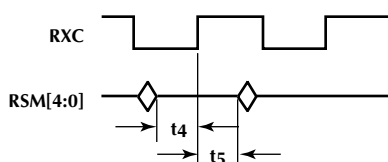

Receive Timing Relationships (Physical Interface)

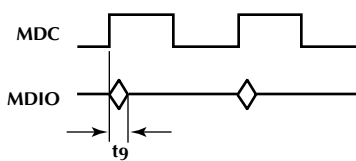

Management Timing Relations (Sourced by PHY)

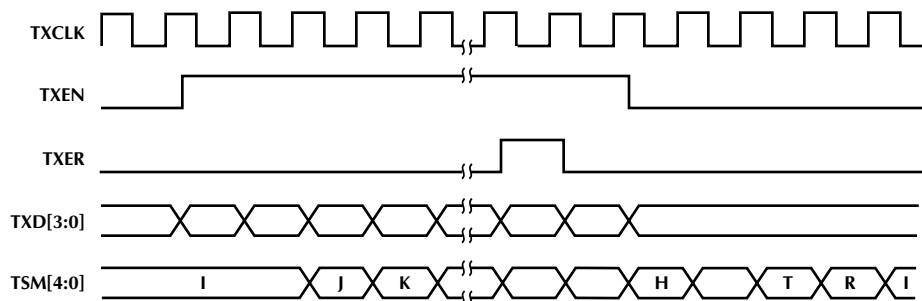

Transmission Timing

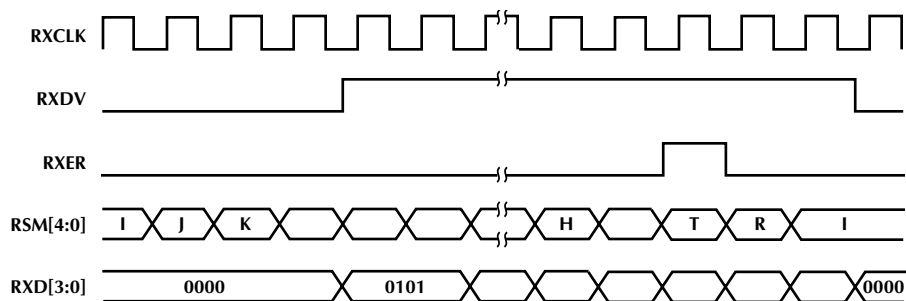

Receiving Timing

FUNCTIONAL DESCRIPTION

To describe the function of the ML6691, the device is separated into three sections, the Transmit Section, the Receive Section, and the Management section. Each section is discussed below.

TRANSMIT SECTION

The transmit section is responsible for converting transmit nibble data on the MII lines from the MAC into encoded and ciphered transmit symbols, as shown in Figure 1. The nibble input register samples the transmit nibble data on the MII lines and passes the nibble data onto the encoder. The encoder then converts the data to 4B/5B code (see Table 1) under the direction of the state machine. The state machine detects the leading edges of transmit enable and impresses the start of frame delimiter — the JK pair — ignoring the TXD<3:0> during these two symbol times. If,

HEX/4B	SYMBOL/5B	HEX/4B	SYMBOL/5B
0000	11110	J	11000
0001	01001	K	10001
0010	10100	T	01101
0011	10101	R	00111
0100	01010	H	00100
0101	01011	IDLE	11111
0110	01110		
0111	01111		
1000	10010		
1001	10011		
1010	10110		
1011	10111		
1100	11010		
1101	11011		
1110	11100		
1111	11101		

Table 1. 4B/5B Encoding Table

while transmit enable is asserted, the transmit error is asserted, the H symbol will be impressed except during the time the JK pair is emitted. Following the trailing edge of transmit enable, the end of frame delimiter — the TR pair — is generated, after which the IDLE symbol is generated to fill the space between frames. The encoded data is then enciphered by performing a XOR with the output of the cipher register.

The cipher register is a linear feedback shift register which generates the cipher bit stream which is used to scramble the transmit symbol data. The Boolean algebra expression is listed below.

$$\begin{aligned}
 \text{TCFR11} &= \text{TCFR6} \\
 \text{TCFR10} &= \text{TCFR5} \\
 \text{TCFR9} &= \text{TCFR4} \\
 \text{TCFR8} &= \text{TCFR3} \\
 \text{TCFR7} &= \text{TCFR2} \\
 \text{TCFR6} &= \text{NOT (TCFR11 OR TCFR10 OR TCFR9 OR} \\
 &\quad \text{TCFR8 OR TCFR7 OR TCFR6 OR TCFR5 OR} \\
 &\quad \text{TCFR4 OR TCFR3 OR TCFR2) OR TCFR1} \\
 \text{TCFR5} &= \text{TCFR11 XOR TCFR9} \\
 \text{TCFR4} &= \text{TCFR10 XOR TCFR8} \\
 \text{TCFR3} &= \text{TCFR9 XOR TCFR7} \\
 \text{TCFR2} &= \text{TCFR8 XOR TCFR6} \\
 \text{TCFR1} &= \text{TCFR7 XOR TCFR5}
 \end{aligned}$$

The enciphered data are then passed to the symbol output register which drives the generated symbol data out to the PMD transceiver.

Collision detect is implemented by noting the occurrence of reception during transmission. A linkfail indication at any time causes an immediate transition to the IDLE state and supersedes any other transmit operation.

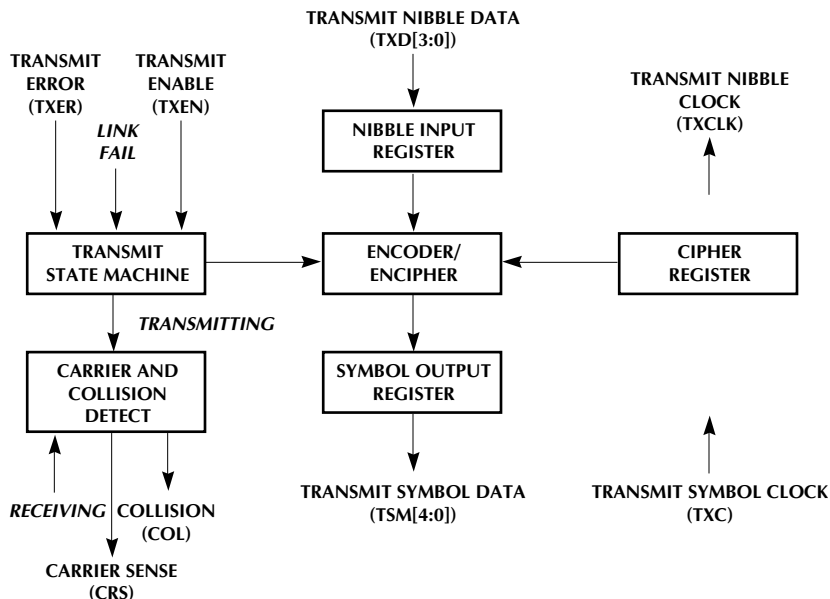

Figure 1. Transmit Section Block Diagram

RECEIVE SECTION

The receive section is responsible for converting received unaligned symbols into deciphered, aligned and decoded nibble data on the MII lines, as shown in Figure 2. The receive symbol input register samples the receive symbol data from the PMD transceiver and passes the symbol data onto the decipher process. The cipher lock is restored by reloading the decipher register after detecting 13 consecutive IDLE symbols which must occur between packets. The decipher function is then performed by an exclusive-OR of the output of the decipher register and the input symbols.

The decipher symbol data are then passed to the symbol aligner. The symbols are broken into arbitrary five-bit groups. The alignment is achieved by scanning the code-bit stream for the JK pair following the idle symbols.

The decoder translates the 4B/5B coded deciphered and aligned symbols into hex nibbles. The decoder along with the state machine also examines the symbol stream for packet framing information. The JK is converted back to 55 and the TR into 00. The decoder also flags invalid symbol codes and generates the receive error signal. The state machine also generates the receive data valid signal.

A premature stream termination is caused by the detection of two IDLE symbols prior to an TR. A linkfail signal will also terminate the receive operation immediately.

Note, the "Bad SSD" state is not implemented in the receive state machine of the ML6691.

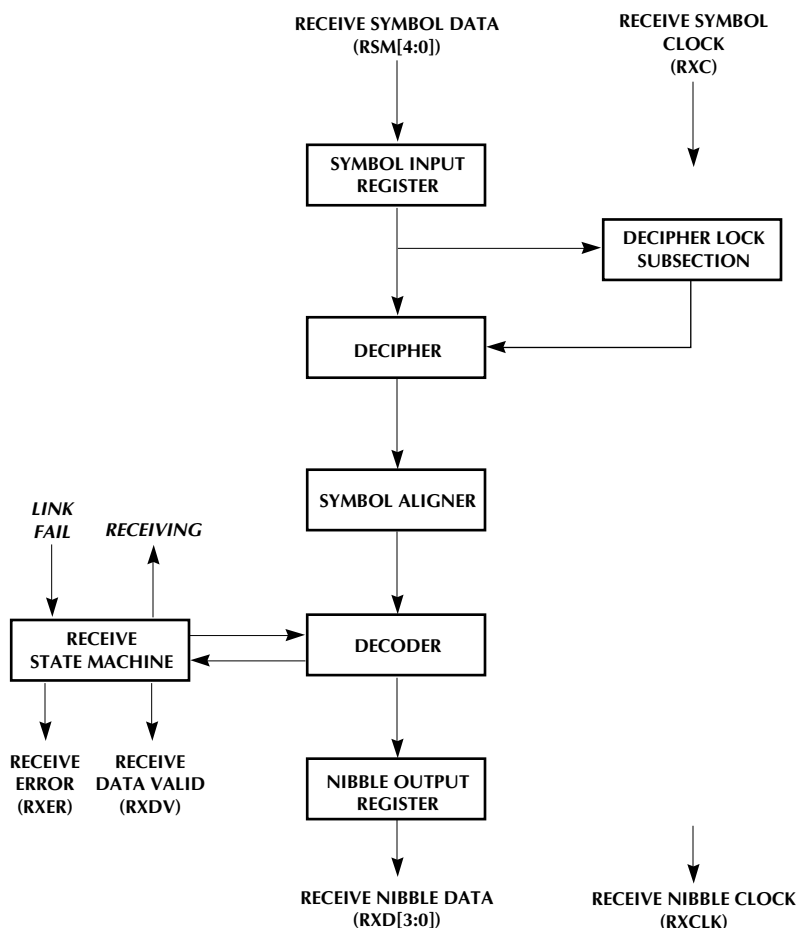

Figure 2. Receive Section Block Diagram

MANAGEMENT SECTION

The ML6691 implements the applicable portions of the IEEE 802.3 Control and Status registers. The management section provides a two-wire serial interface for the purpose of control and status gathering. The MDIO pin is

a bi-directional signal used to transfer control information between the ML6691 and the MAC. Data on MDIO is clocked using the MDC pin. The following frame structure is used:

	PRE	ST	OP	PHYAD	REGAD	TA	DATA	IDLE
READ	1	01	10	AAAAA	RRRRR	Z0	DDDDDDDDDDDDDDDDDD	Z
WRITE	1	01	01	AAAAA	RRRRR	10	DDDDDDDDDDDDDDDDDD	Z

PRE (Preamble)

The preamble condition on the two wire interface is a logic one. Prior to initiation of any other transaction, a sequence of 32 consecutive logic ones must be presented on MDIO with 32 corresponding cycles on MDC to establish synchronization.

ST (Start of Frame)

The start of frame is indicated by a <01> pattern. This pattern assures transitions from the default logic one line state to zero and back to one.

OP (Operation Code)

The operation code for a read transaction is <10>, while the operation code for a write transaction is <01>.

PHYAD (PHY Address)

The PHY Address is five bits, allowing 32 unique PHY addresses. The first PHY address bit transmitted and received is the MSB of the address.

REGAD (Register Address)

The Control register is address <00000>, and the Status register is address <00001>.

TA (Turnaround)

The turnaround time is a 2 bit time spacing between the Register Address field and the Data field of a management frame to avoid contention during a read transaction.

DATA (Data)

The data field is 16-bits. The first data bit transmitted and received shall be bit 15 of the register being addressed.

CONTROL REGISTER

Table 2 shows the applicable portions of the Control registers that are implemented in the ML6691. Bits 12, 9, and 6–0 are read-only and have default values of logic low.

CONTROL REGISTER

BIT	NAME	DESCRIPTION	R/W	DEFAULT
15	Reset	1 = reset 0 = normal operation	R/W SC	0
14	Loopback	1 = loopback 0 = normal operation	R/W	0
13	Speed Selection	1 = 100Mb/s 0 = 10Mb/s	R	1
11	Power Down	1 = power down 0 = normal operation	R/W	0
10	Isolate	1 = electrically isolate from MII 0 = normal operation	R/W	Determined by LOCAL
8	Duplex Mode	1 = full duplex 0 = half duplex	R/W	0
7	Collision Test	1 = test Col signal 0 = normal operation	R/W	0

NOTE: R/W = Read/Write, SC = Self Clearing

Table 2. Control Register

Reset: By setting this bit to a logic one, the Control register will be reset to its default values. This bit self-clears upon completion of the reset operation.

Loopback: By setting this bit to a logic one, the `LPBK` pin will be held at a logic low. The COL signal will remain low at all times, unless bit 7 is set, in which case the COL signal shall behave as described.

Speed Selection: This bit is read-only and set at a logic one by default.

Power Down: By setting this bit to a logic one, the oscillator and all the MII input buffers except for MDIO and MDC will be shut down.

Isolate: By setting this bit a logic one, the ML6691 can be electrically isolated from the MII. In the isolation mode, the input TXEN will be ignored and TXD[3:0] and TXER shall not have any effect on the transmit section. All the output buffers connected to the MII will be tri-stated. The default state of this bit is determined by the LOCAL pin.

Duplex Mode: ML6691 will operate in Full Duplex mode when this bit is set to a logic one. The COL signal will remain low unless bit 7 is set.

Collision Test: By setting this bit to a logic one, the COL signal will be asserted in response to the assertion of TXEN, and will continue to assert the COL signal until TXEN is deasserted.

STATUS REGISTER

Table 3 shows the applicable portions of the Status register that are implemented in the ML6691. Bits 15, 12-3, 1, and 0 are read-only and have default values of logic low.

100BASE-TX Full Duplex

ML6691 can perform full duplex link transmission and reception using the 100BASE-TX signaling specification. This bit is always read as a logic one.

100BASE-TX Half Duplex

ML6691 can perform half duplex link transmission and reception using the 100BASE-TX signaling specification. This bit is always read as a logic one.

Link Status

When read as a logic one, this bit indicates that a valid link has been established. The link status bit is implemented with a latching function, such that the occurrence of a link failure condition will cause the link status bit to become cleared and remain cleared until it is read via the management interface.

STATUS REGISTER

BIT	NAME	DESCRIPTION	R/W
14	100Base-TX Full Duplex	1 = able to perform full duplex 0 = not able to perform full duplex	R/O
13	100Base-TX Half Duplex	1 = able to perform full duplex 0 = not able to perform full duplex	R/O
2	Link Status	1 = link is up 0 = link is down	R/O LL

NOTE: R/O = Read Only,
LL = Latching Low

Table 3. Status Register

PHYSICAL DIMENSIONS inches (millimeters)

Package: Q44
44-Pin PLCC

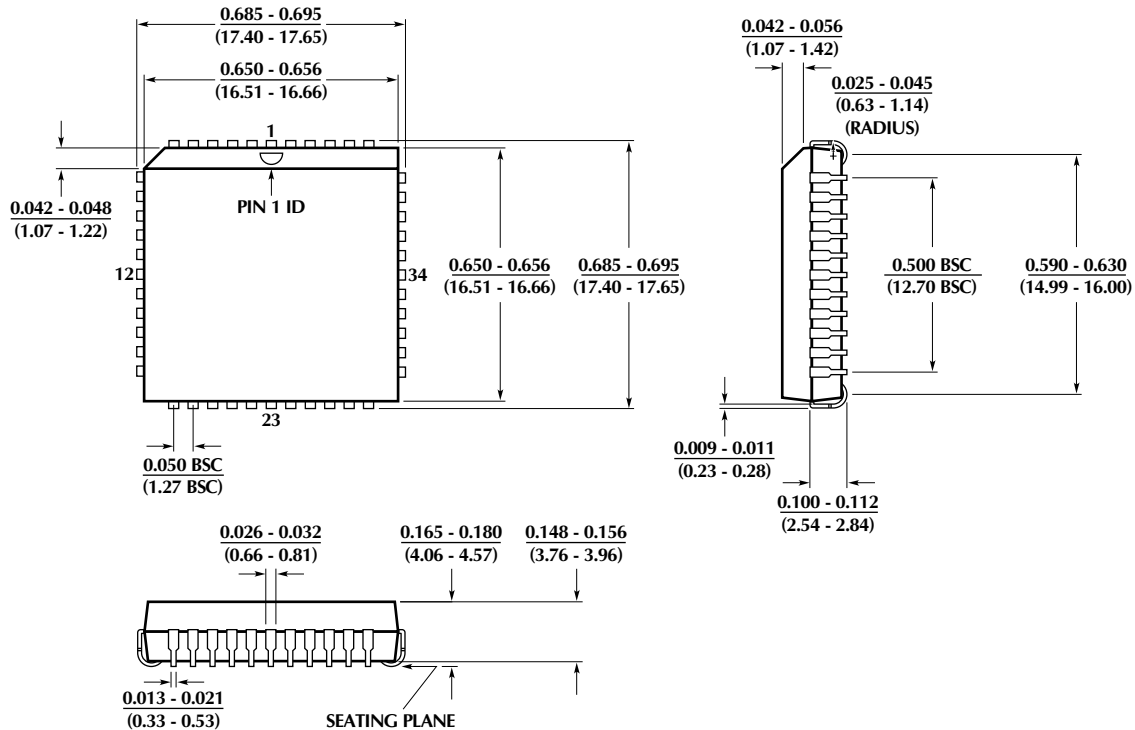

ORDERING INFORMATION

PART NUMBER	TEMPERATURE RANGE	PACKAGE
ML6691CQ	0°C to 70°C	44-PIN PLCC (Q44) (End Of Life)

© Micro Linear 1997. **Micro Linear** is a registered trademark of Micro Linear Corporation

Products described in this document may be covered by one or more of the following patents, U.S.: 4,897,611; 4,964,026; 5,027,116; 5,281,862; 5,283,483; 5,418,502; 5,508,570; 5,510,727; 5,523,940; 5,546,017; 5,559,470; 5,565,761; 5,592,128; 5,594,376; Japan: 2598946. Other patents are pending.

Micro Linear reserves the right to make changes to any product herein to improve reliability, function or design. Micro Linear does not assume any liability arising out of the application or use of any product described herein, neither does it convey any license under its patent right nor the rights of others. The circuits contained in this data sheet are offered as possible applications only. Micro Linear makes no warranties or representations as to whether the illustrated circuits infringe any intellectual property rights of others, and will accept no responsibility or liability for use of any application herein. The customer is urged to consult with appropriate legal counsel before deciding on a particular application.

2092 Concourse Drive
San Jose, CA 95131
Tel: 408/433-5200
Fax: 408/432-0295π