

2-Stage Bluetooth & WLAN InGaP HBT Power Amplifier

Description:

The CGB240B GaAs power amplifier MMIC has been especially developed for wireless LAN applications in the 2.4 - 2.5 GHz ISM band, compliant with IEEE 802.11b standards. The chip is also fully compliant with Bluetooth class 1 applications and thus can be used in dual-mode (Bluetooth/WLAN) applications, too.

While providing an effective channel power of 22dBm, the ACPR is better than -33dB relative to the sinx/x spectral peak of an IEEE802.11b-modulated TX signal. Each CGB240B chip is individually tested for IP3, resulting in guaranteed ACPR performance.

In a Bluetooth class 1 system, the CGB240B's high power added efficiency (up to 50%) and single positive supply operation makes the device ideally suited for handheld applications. The CGB240B delivers 23 dBm output power at a supply voltage of 3.2 V, with an overall *PAE* of 50% in saturated mode. The output power can be adjusted using an analog control voltage (V_{CTR}). Simple external input-, interstage-, and output matching circuits are used to adapt to the different requirements of linearity and harmonic suppression in various applications 2-stage InGaP HBT power amplifier for WLAN and Bluetooth applications.

Features:

- Pout = +23dBm at 3.2 V
- ACPR / IP3 tested to be compliant with IEEE802.11b standard
- Fully compliant with Bluetooth requirements (dual-mode use)
- Single voltage supply
- Wide operating voltage range 2.0 - 5.5 V
- Analog power control with four power steps
- Easy external matching concept

Applications:

- WLAN
- IEEE 802.11a
- Bluetooth Class 1

Package Outline:

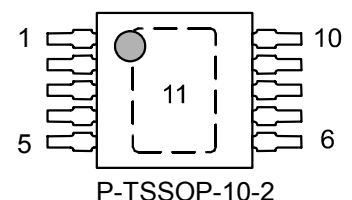

Pin configuration:

1 & 2:	Vc1
3:	RFin
4, 5, & 10:	NC
6:	Vcntrl1
7:	Vcntro2
8 & 9:	Vc2
11 (paddle)	GND

CGB240B Datasheet

Absolute Maximum Ratings:

Parameter	Symbol	Limit Values		Unit
		min.	max.	
Max. Supply Voltage CW	$V_{CC, MAX}$	0	5.5	V
Max. Supply Voltage Pulsed	$V_{CCP, MAX}$	0	5.0	V
Max. Control Voltage	$V_{CTR, MAX}$	0	3.5	V
Max. Current Stage 1	$I_{C1, MAX}$	0	40	mA
Max. Current Stage 2	$I_{C2, MAX}$	0	180	mA
Max. Total Power Dissipation ¹⁾	P_{TOT}		650	mW
Max. RF Input Power ²⁾	$P_{IN, MAX}$		+10	dBm
Max. RF Output Power ²⁾	$P_{OUT, MAX}$		+25	dBm
Operating Temperature Range	T_A	- 40	+85	°C
Max. Junction Temperature ¹⁾	T_{Ch}		150	°C
Storage Temperature	T_{Stg}	- 55	150	°C

¹⁾ Thermal resistance between junction and pad 11 (= heatsink): $R_{THCH} = 100$ K/W.

²⁾ No RF input signal should be applied at turn on of DC Power. An output VSWR of 1:1 is assumed.

Typical Electrical Characteristics of CGB240B for IEEE802.11b Applications

(Typical data for CGB240B reference application board, see application note 1)

$T_A = 25$ °C; $V_{CC} = V_{CTR} = 3.3$ V; $f = 2.45$ GHz; $Z_{IN, Board} = Z_{OUT, Board} = 50$ Ohms

Parameter	Symbol	Limit Values			Unit	Test Conditions
		min	typ	max		
Supply Current Small-Signal Operation	$I_{CC, SS}$		190		mA	$P_{IN} = -10$ dBm
Power Gain Small-Signal Operation	G_{SS}		28		dB	$P_{IN} = -10$ dBm
Adjacent Channel Power Ratio	$ACPR$		- 33		dBr	$P_{OUT} = +22$ dBm $f = f_C \pm f_{MOD}$ $f_C = 2.4..2.5$ GHz $f_{MOD} = 11..22$ MHz.
Output Power	P_{OUT}		+22		dBm	$ACPR < -33$ dBr
Power Added Efficiency	PAE		25		%	$P_{OUT} = +22$ dBm

CGB240B Datasheet

Electrical Characteristics of CGB240B Device used in Bluetooth PA Reference Design (See Application Note 2)

$T_A = 25\text{ }^\circ\text{C}$; $V_{CC} = 3.2\text{ V}$; $f = 2.4 \dots 2.5\text{ GHz}$; $Z_{IN,Board} = Z_{OUT,Board} = 50\text{ Ohms}$

Parameter	Symbol	Limit Values			Unit	Test Conditions
		min	typ	max		
Supply Current Small-Signal Operation	$I_{CC,SS}$	100	130	150	mA	$P_{IN} = -10\text{ dBm}$ $V_{CTR} = 2.5\text{ V}$
Power Gain Small-Signal Operation	G_{SS}	23	25	27	dB	$P_{IN} = -10\text{ dBm}$ $V_{CTR} = 2.5\text{ V}$
Output Power Power Step 1	$P_{OUT,1}$		7		dBm	$P_{IN} = +3\text{ dBm}$ $V_{CTR} = 1.15\text{ V}$
Supply Current Power Step 1	$I_{CC,1}$		15		mA	$P_{IN} = +3\text{ dBm}$ $V_{CTR} = 1.15\text{ V}$
Power Added Efficiency Power Step 1	PAE_1		10		%	$P_{IN} = +3\text{ dBm}$ $V_{CTR} = 1.15\text{ V}$
Output Power Power Step 2	$P_{OUT,2}$		12		dBm	$P_{IN} = +3\text{ dBm}$ $V_{CTR} = 1.3\text{ V}$
Supply Current Power Step 2	$I_{CC,2}$		25		mA	$P_{IN} = +3\text{ dBm}$ $V_{CTR} = 1.3\text{ V}$
Power Added Efficiency Power Step 2	PAE_2		20		%	$P_{IN} = +3\text{ dBm}$ $V_{CTR} = 1.3\text{ V}$
Output Power Power Step 3	$P_{OUT,3}$		17		dBm	$P_{IN} = +3\text{ dBm}$ $V_{CTR} = 1.5\text{ V}$
Supply Current Power Step 3	$I_{CC,3}$		52		mA	$P_{IN} = +3\text{ dBm}$ $V_{CTR} = 1.5\text{ V}$
Power Added Efficiency Power Step 3	PAE_3		32		%	$P_{IN} = +3\text{ dBm}$ $V_{CTR} = 1.5\text{ V}$
Output Power Power Step 4	$P_{OUT,4}$	22	23	24	dBm	$P_{IN} = +3\text{ dBm}$ $V_{CTR} = 2.5\text{ V}$
Supply Current Power Step 4	$I_{CC,4}$		130		mA	$P_{IN} = +3\text{ dBm}$ $V_{CTR} = 2.5\text{ V}$
Power Added Efficiency Power Step 4	PAE_4	40	50	-	%	$P_{IN} = +3\text{ dBm}$ $V_{CTR} = 2.5\text{ V}$
2 nd Harm. Suppression Power Step 4	h_2		-35		dBc	$P_{IN} = +3\text{ dBm}$ $V_{CTR} = 2.5\text{ V}$
3 rd Harm. Suppression Power Step 4	h_3		-50		dBc	$P_{IN} = +3\text{ dBm}$ $V_{CTR} = 2.5\text{ V}$

CGB240B Datasheet

General Electrical Characteristics of CGB240B

Parameter	Symbol	Limit Values			Unit	Test Conditions
		min	typ	max		
Turn-Off Current	$I_{CC, OFF}$			1	uA	$V_{CC} = 3.2 \text{ V}$ $V_{CTR} < 0.4 \text{ V}$ No RF Input
Off-State Isolation	$S_{21, 0}$		26		dB	$P_{IN} = + 3 \text{ dBm}$ $V_{CTR} = 0 \text{ V}$
Rise Time 1 ³⁾	T_{R1}			1	μs	$V_{CC} = 5.0 \text{ V}$ $V_{CTR} = 0 \text{ to } 1\text{V Step}$
Rise Time 2 ³⁾	T_{R2}			1	μs	$V_{CC} = 5.0 \text{ V}$ $V_{CTR} = 0 \text{ to } 3\text{V Step}$
Fall Time 1 ³⁾	T_{F1}			1	μs	$V_{CC} = 5.0 \text{ V}$ $V_{CTR} = 1 \text{ to } 0\text{V Step}$
Fall Time 2 ³⁾	T_{F2}			1	μs	$V_{CC} = 5.0 \text{ V}$ $V_{CTR} = 3 \text{ to } 0\text{V Step}$
Maximum Load VSWR allowed for 10s (no damage to device)	V_{SWR}			6		$P_{IN} = + 5 \text{ dBm}$ $V_{CC} = 4.8 \text{ V}$ $V_{CTR} = 2.5 \text{ V}$ $Z_{IN} = 50 \text{ Ohms}$

- ³⁾ Rise time T_R defined as time between turn-on of V_{CTR} voltage until reach of 90% of full output power level.
Fall time T_F defined as time between turn-off of V_{CTR} voltage until reach of 10% of full output power level.
Please note: Reduced Vccp, max for pulsed operation applies (see "absolute maximum ratings").

CGB240B Datasheet

Typical S-Parameters for IEEE802.11b Operation

$T_A = 25\text{ }^\circ\text{C}$; $V_{CC} = 3.3\text{ V}$; $V_{CTR} = 3.3\text{ V}$; Port 1: RF In (Pin 3); Port 2: RF Out (Pins 8/9)

$P_{IN} < -10\text{ dBm}$; Interstage match and DC bias circuit according to application note 1.

Frequency (GHz)	S11		S21		S12		S21	
	Real (x1)	Imag (x1)	Real (x1)	Imag (x1)	Real (x1)	Imag (x1)	Real (x1)	Imag (x1)
0.2	0,31	-0,10	10,46	-2,89	0,0002	0,0001	-0,47	-0,02
0.4	0,29	-0,22	2,51	0,20	0,0001	0,0003	-0,60	0,05
0.6	0,17	-0,31	6,10	1,73	-0,0004	0,0015	-0,61	0,11
0.8	0,04	-0,34	8,57	-0,46	-0,0001	0,0017	-0,60	0,16
1	-0,06	-0,35	9,25	-3,27	0,0003	0,0022	-0,59	0,20
1.2	-0,16	-0,35	8,65	-6,18	0,0004	0,0028	-0,57	0,22
1.4	-0,27	-0,34	7,17	-8,66	0,0007	0,0030	-0,56	0,24
1.6	-0,37	-0,32	5,11	-10,46	0,0008	0,0034	-0,55	0,26
1.8	-0,47	-0,27	2,70	-11,63	0,0012	0,0043	-0,54	0,30
2	-0,57	-0,22	-0,36	-12,67	0,0026	0,0046	-0,50	0,32
2.2	-0,67	-0,11	-3,71	-12,10	0,0025	0,0051	-0,47	0,34
2.3	-0,70	-0,04	-5,32	-11,58	0,0026	0,0049	-0,46	0,36
2.4	-0,73	0,04	-6,88	-10,53	0,0026	0,0048	-0,44	0,37
2.5	-0,74	0,12	-8,18	-9,49	0,0034	0,0051	-0,43	0,39
2.6	-0,74	0,21	-9,23	-8,10	0,0033	0,0055	-0,41	0,41
2.8	-0,69	0,36	-10,40	-4,99	0,0044	0,0059	-0,35	0,44
3	-0,63	0,51	-10,94	-2,12	0,0053	0,0066	-0,30	0,48
3.2	-0,53	0,63	-10,59	0,72	0,0061	0,0067	-0,24	0,50
3.4	-0,41	0,72	-9,16	3,05	0,0084	0,0070	-0,17	0,50
3.6	-0,30	0,77	-7,78	4,53	0,0088	0,0050	-0,12	0,51
3.8	-0,21	0,80	-6,26	5,45	0,0105	0,0051	-0,04	0,51
4	-0,12	0,82	-4,62	6,47	0,0119	0,0033	0,06	0,47

Note: Table available as S2P file.

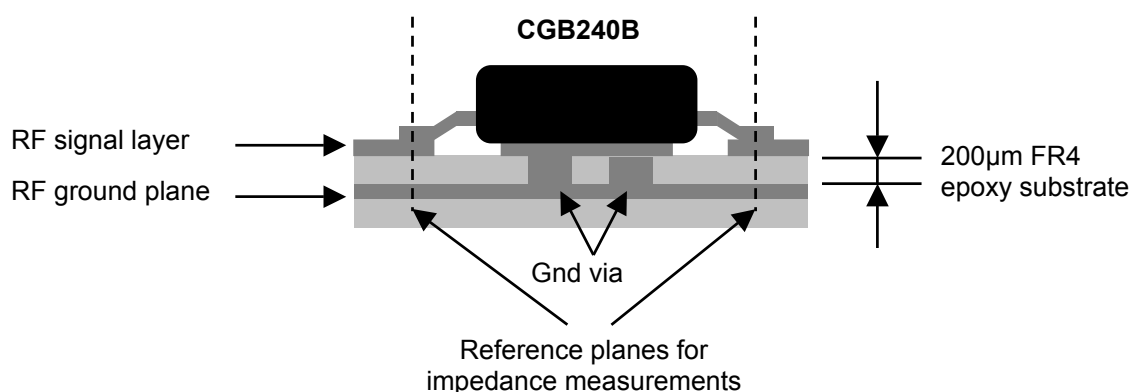

Figure 1 Ground plane configuration and impedance reference planes.

The impedance reference plane is located at the center of the device pin, assuming that a continuous microstrip ground plane exists and that low-inductance (e.g. 6-via) connections of the device's center ground pad (11) to the microstrip ground plane are present.

CGB240B Datasheet

Operational Impedances for Bluetooth Application

$T_A = 25\text{ }^\circ\text{C}$; $V_{CC} = 2.8\text{ to }3.2\text{ V}$; $V_{CTR} = 2.5\text{ to }2.8\text{ V}$; $f = 2.4 \dots 2.5\text{ GHz}$

$P_{IN} = +3\text{ dBm}$ (Large signal operation; PA in compression)

Parameter (Target Data)	Symbol	Typ. Value	Unit
Generator Impedance ⁴⁾	Z_{GEN}	$9 - j 1$	Ohms
Interstage Termination ⁵⁾	Z_{IS}	$1 + j 12.5$	Ohms
Load Impedance	Z_{LOAD}	$15 + j 3$	Ohms

⁴⁾ Generator impedance equals approximately conjugate complex input impedance: $Z_{IN} \approx Z_{GEN}^*$

⁵⁾ Z_{IS} is the impedance to be presented to the interstage output (pin 1 and pin 2) of the device.

The given load impedance is optimized for output power in saturated mode (Bluetooth) and does not represent the conjugate complex output impedance of the device since large signal conditions apply.

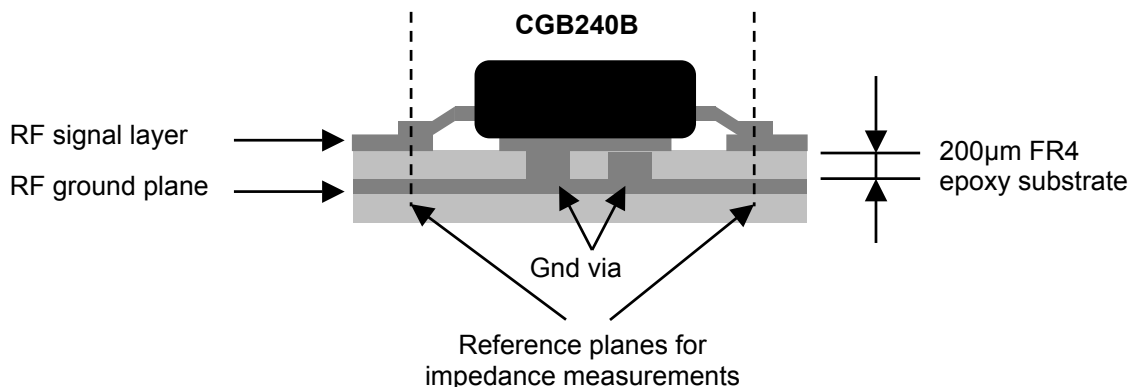

Figure 2 Ground plane configuration and impedance reference planes.

The impedance reference plane is located at the center of the device pin, assuming that a continuous microstrip ground plane exists and that low-inductance (e.g. 6-via) connections of the device's center ground pad (11) to the microstrip ground plane are present.

CGB240B Datasheet

Typical Device Performance for IEEE802.11b Reference Design (see Application Note 1)

Valid for all plots: $T_A = 25\text{ }^\circ\text{C}$; $V_{CC} = 3.3\text{ V}$; $V_{CTR} = 3.3\text{ V}$; $f = 2.45\text{ GHz}$;

Output Power Compression $P_{OUT} = f(P_{IN})$

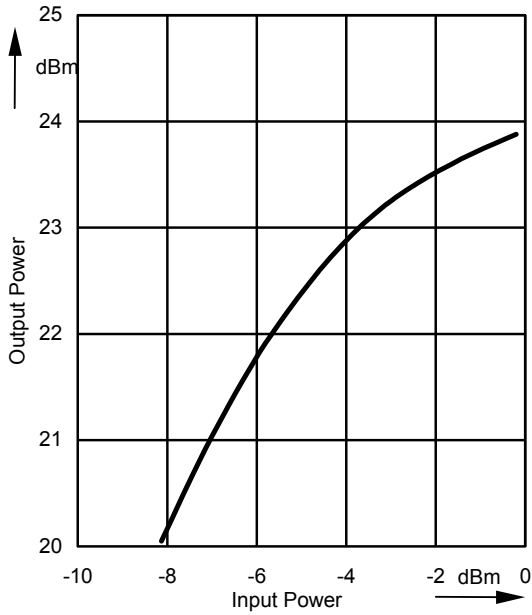

ACPR for IEEE802.11b Modulation $ACPR_{IEEE802.11b} = f(P_{OUT})$

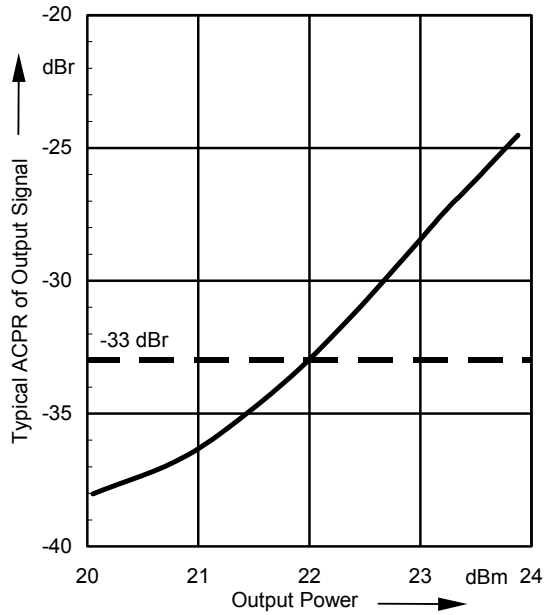

Optimum Input Power $P_{IN} = f(T)$

$ACPR_{IEEE802.11b} < -33\text{dBr}$, $P_{OUT} > 22\text{dBm}$

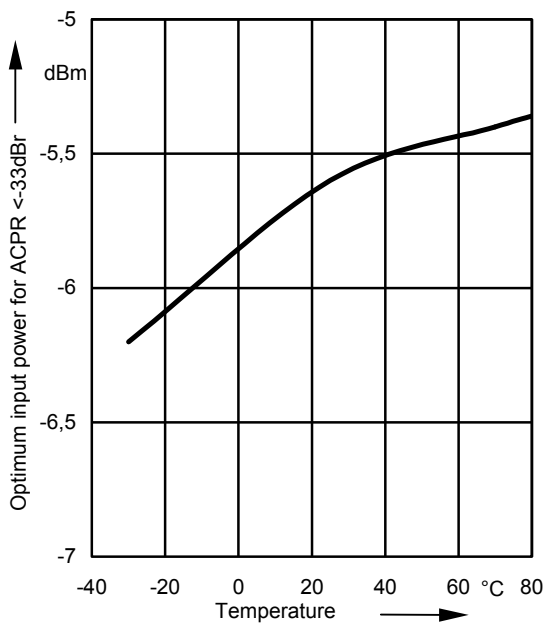

Output Power $P_{OUT} = f(T)$

$ACPR_{IEEE802.11b} < -33\text{dBr}$

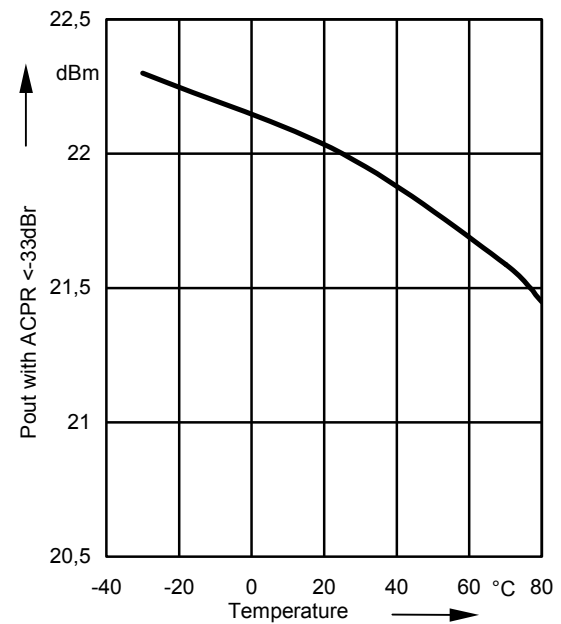

CGB240B Datasheet

Typical Device Performance for Bluetooth Reference Design

(see Application Note 2)

Valid for all plots: $T_A = 25\text{ }^\circ\text{C}$; $V_{CC} = 3.2\text{ V}$; $V_{CTR} = 2.5\text{ V}$; $f = 2.4 \dots 2.5\text{ GHz}$;

Efficiency PAE = $f(V_{CC})$

$P_{IN} = +3\text{dBm}$

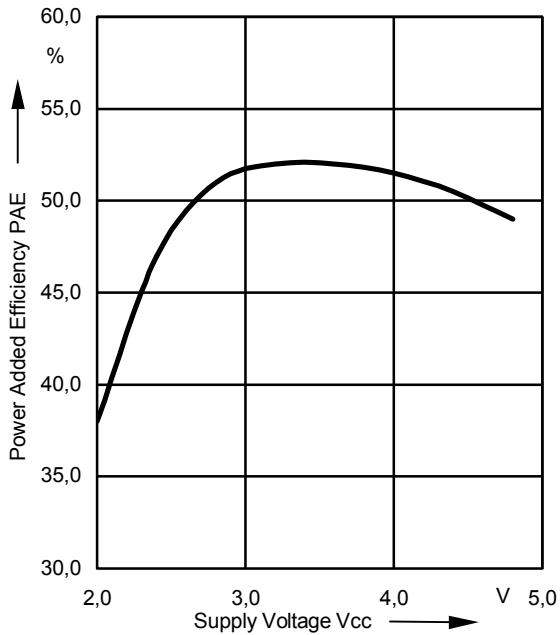

Output Power $P_{OUT} = f(V_{CC})$

$P_{IN} = +3\text{dBm}$

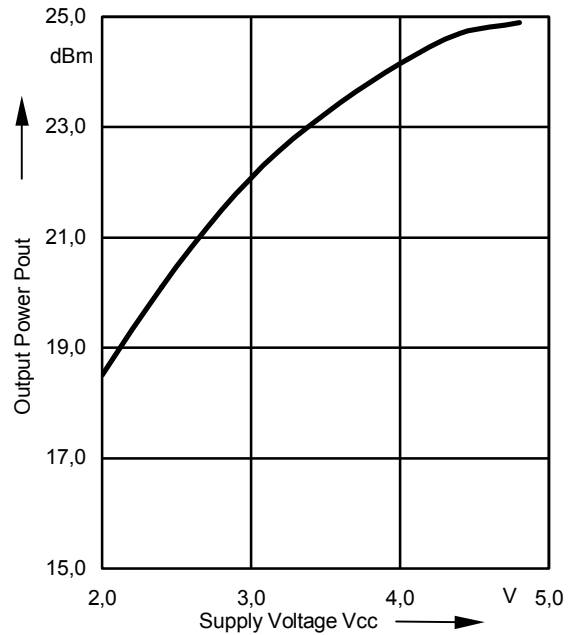

Supply Current $I_{CC} = f(V_{CTR})$

$P_{IN} = +3\text{dBm}$

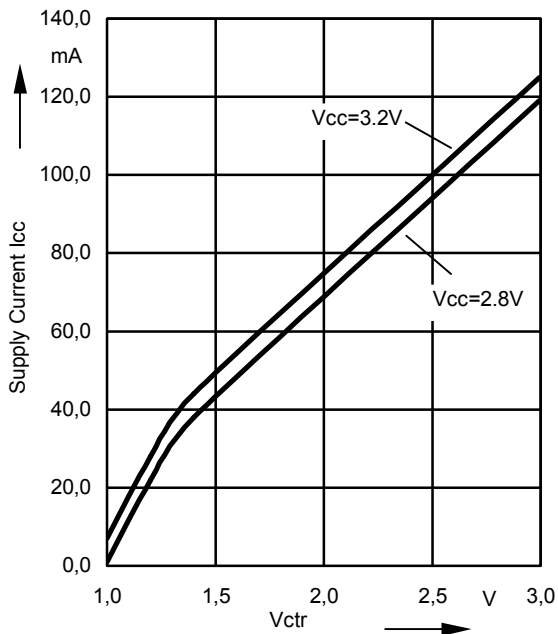

Output Power $P_{OUT} = f(V_{CTR})$

$P_{IN} = +3\text{dBm}$

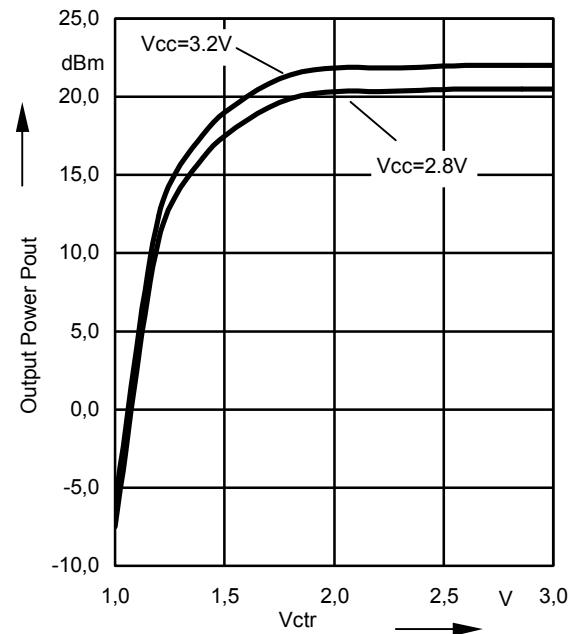

CGB240B Datasheet

Typical Device Performance for Bluetooth Reference Design (cont.)

Output Power Compression $P_{OUT} = f(P_{IN})$

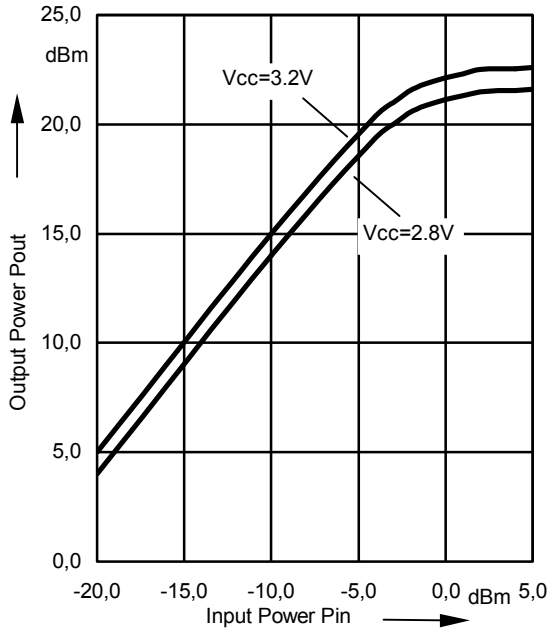

Supply Current $I_{CC} = f(T_A)$

$P_{IN} = +3\text{dBm}, V_{CC} = 3.2\text{V}$

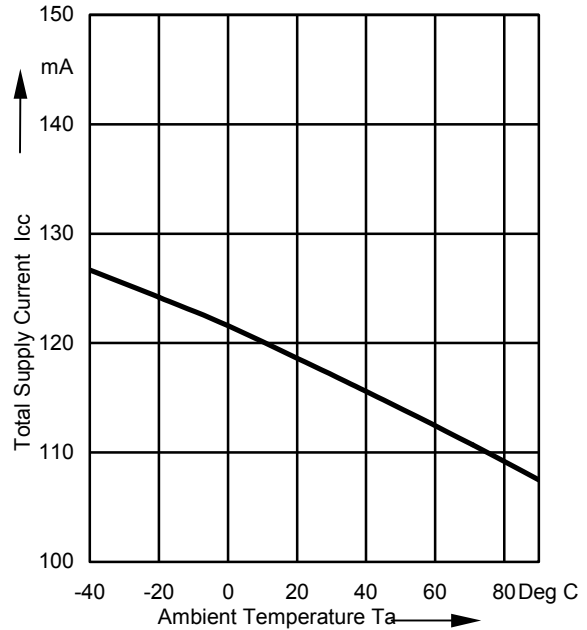

Output Power $P_{OUT} = f(T_A)$

$P_{IN} = +3\text{dBm}$

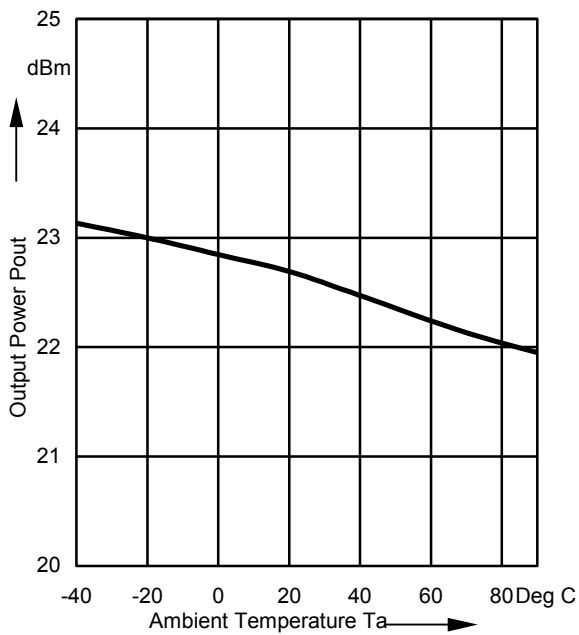

Small-Signal Gain $S_{21} = f(T_A)$

$P_{IN} = -10\text{ dBm}, V_{CC} = 3.2\text{V}$

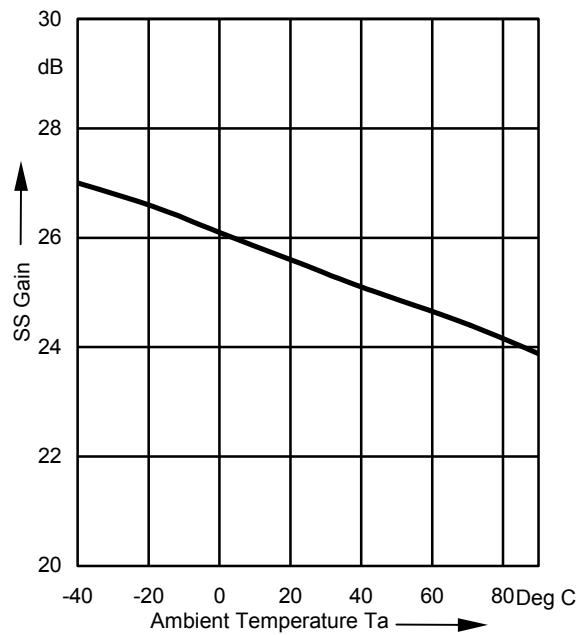

CGB240B Datasheet

Pinning

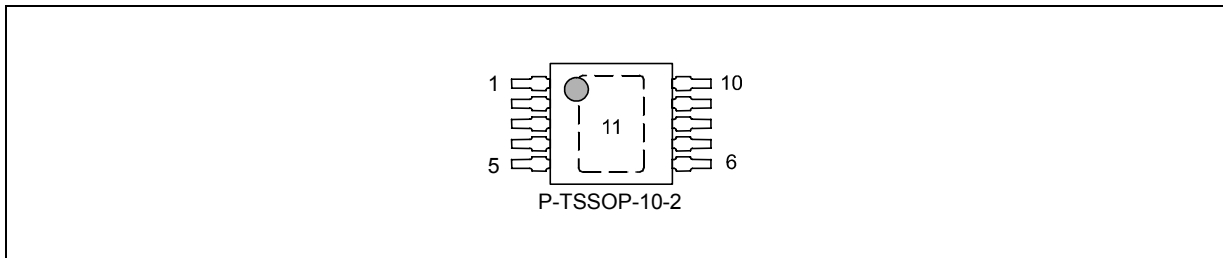

Figure 3 CGB240B Outline

Pad	Symbol	Function
1	V_{C1}	Supply voltage of 1 st stage / interstage match
2	V_{C1}	Supply voltage of 1 st stage / interstage match
3	RF_{IN}	RF input
4	N.C.	
5	N.C.	
6	V_{CTR1}	Control voltage 1 st stage
7	V_{CTR2}	Control voltage 2 nd stage
8	V_{C2}	Supply voltage of 2 nd stage / RF output
9	V_{C2}	Supply voltage of 2 nd stage / RF output
10	N.C.	
11	GND	RF and DC ground (pad located on backside of package) Heatsink. Thermal resistance between junction – pad 11: $R_{THCH} = 100$ K/W.

Functional Diagram

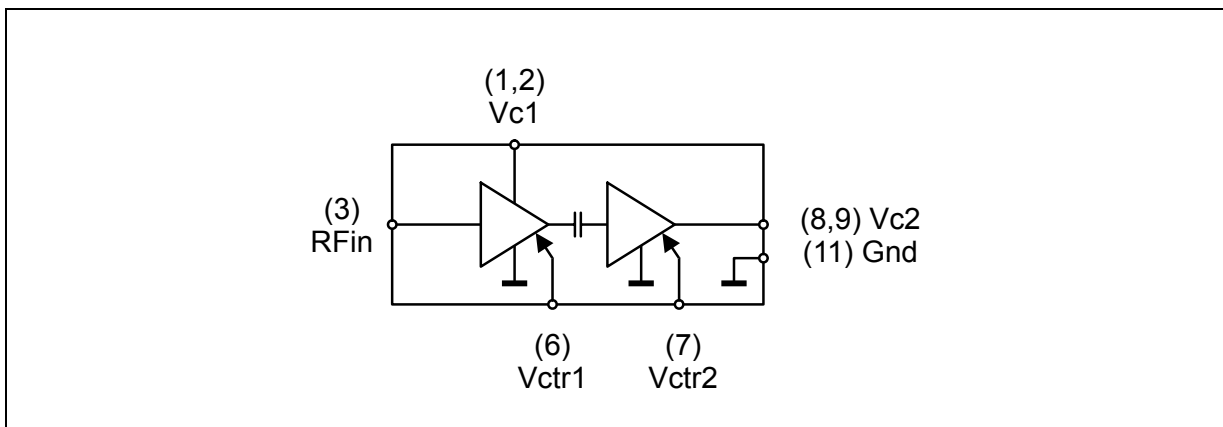

Figure 4 CGB240B Functional Diagram

CGB240B Datasheet

Application Note 1: High Power 22dBm IEEE802.11b Power Amplifier

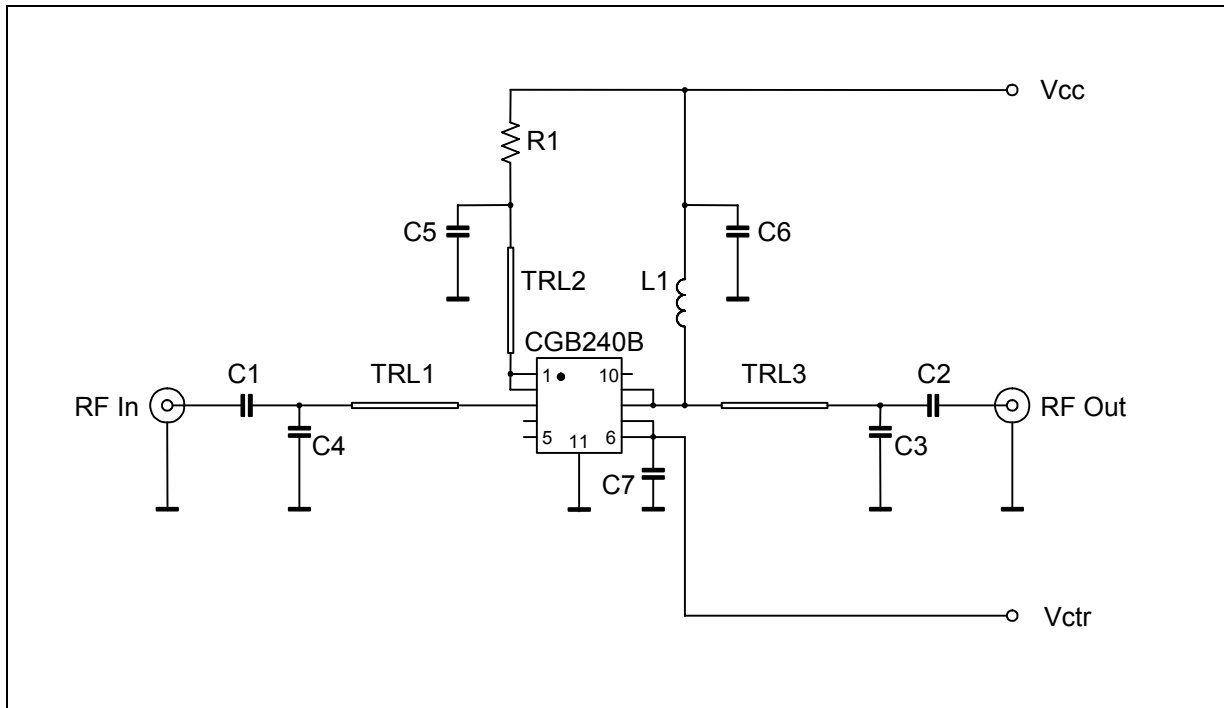

Figure 5 IEEE802.11b WLAN Power Amplifier.

Part	Type	Value	Outline	Source	Part No.
C1	Cer. Capacitor	22 pF	0402	Murata COG	
C2	Cer. Capacitor	22 pF	0402	Murata COG	
C3	Cer. Capacitor	1.5 pF	0603	AVX ACCU-P	06035J1R5BBT
C4	Cer. Capacitor	2.2 pF	0402	Murata COG	
C5	Cer. Capacitor	82 pF	0402	Murata COG	
C6	Cer. Capacitor	1 μ F	0603	Murata X7R	
C7	Cer. Capacitor	1 nF	0402	Murata X7R	
L1	Inductor	22 nH	0603	Toko	LL1608-FS
R1	Resistor	10 Ω	0402	Mira	
TRL1 ⁶⁾	Microstrip Line	$l = 2,5$ mm; FR4: $\epsilon_r = 4.8$; $h = 0,2$ mm; $w = 0,32$ mm			
TRL2 ⁸⁾	Microstrip Line	$l = 1,0$ mm; FR4: $\epsilon_r = 4.8$; $h = 0,2$ mm; $w = 0,32$ mm			
TRL3 ⁸⁾	Microstrip Line	$l = 2,8$ mm; FR4: $\epsilon_r = 4.8$; $h = 0,2$ mm; $w = 0,32$ mm			

⁸⁾ Line length measured from corner of capacitor to end of MMIC's lead.

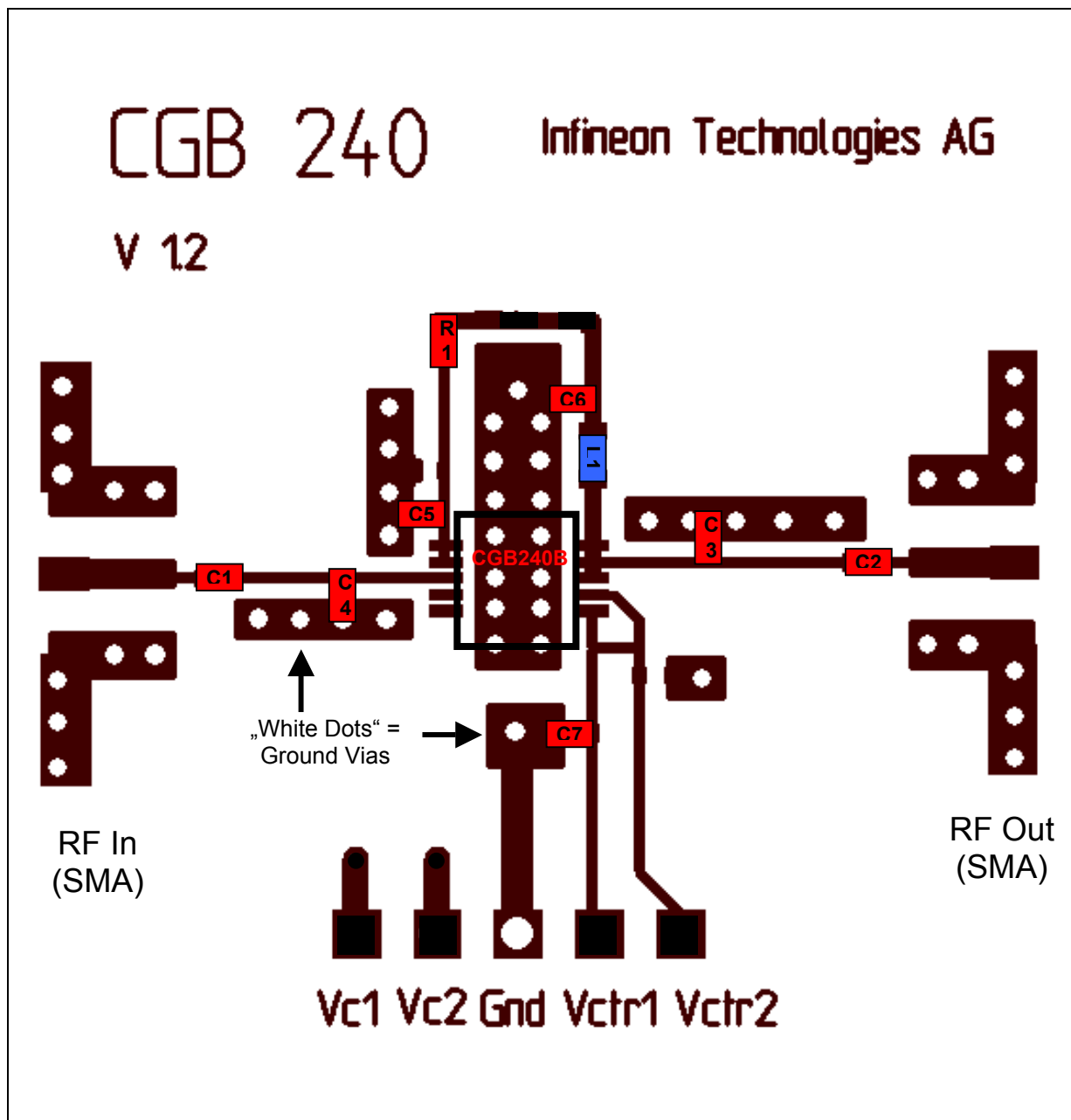

Figure 6 Layout of CGB240B evaluation board tuned for IEEE802.11b WLAN application (see application note 1).

Vc1 and Vc2 are connected together on the PCB.

Vctr1 and Vctr2 are connected together on the PCB.

CGB240B Datasheet

Application Note 2: Bluetooth PA Reference Design using CGB240B

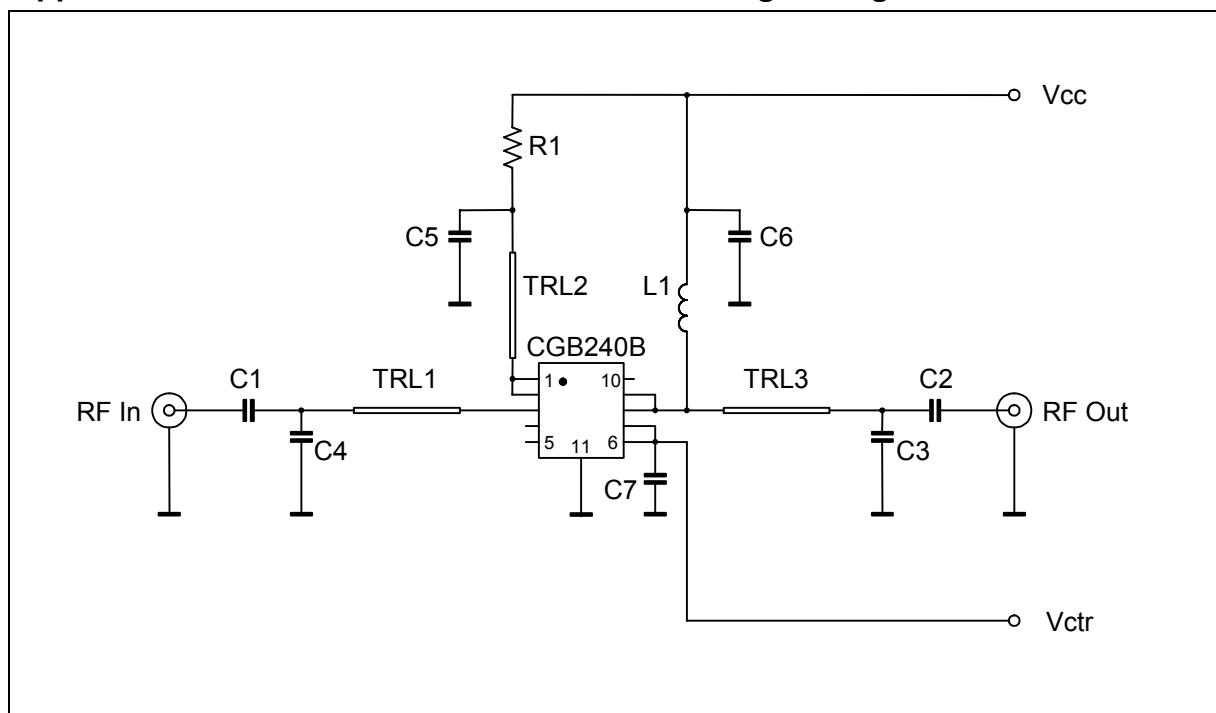

Figure 7 Schematic of Bluetooth PA reference design using CGB240B.

Part	Type	Value	Outline	Source	Part No.
C1	Cer. Capacitor	22 pF	0402	Murata COG	
C2	Cer. Capacitor	22 pF	0402	Murata COG	
C3 ⁷⁾	Cer. Capacitor	1.5 pF	0603	AVX ACCU-P	06035J1R5BBT
C4	Cer. Capacitor	2.2 pF	0402	Murata COG	
C5	Cer. Capacitor	10 pF	0402	Murata COG	
C6	Cer. Capacitor	1 μ F	0603	Murata X7R	
C7	Cer. Capacitor	1 nF	0402	Murata X7R	
L1	Inductor	22 nH	0603	Toko	LL1608-FS
R1	Resistor	10 Ω	0402	Mira	
TRL1 ⁸⁾	Microstrip Line	$l = 2,5$ mm; FR4 - $\epsilon_r = 4.8$; $h = 0,2$ mm; $w = 0,32$ mm			
TRL2 ⁸⁾	Microstrip Line	$l = 1,8$ mm; FR4 - $\epsilon_r = 4.8$; $h = 0,2$ mm; $w = 0,32$ mm			
TRL3 ⁸⁾	Microstrip Line	$l = 4,0$ mm; FR4 - $\epsilon_r = 4.8$; $h = 0,2$ mm; $w = 0,32$ mm			

⁷⁾ Cost optimization might take place by using lower-Q AVX-CU capacitors instead of the AccuP version. This will lead to better h_2 performance, however resulting in a loss of about 2% PAE.

⁸⁾ Line length measured from corner of capacitor to end of MMIC's lead.

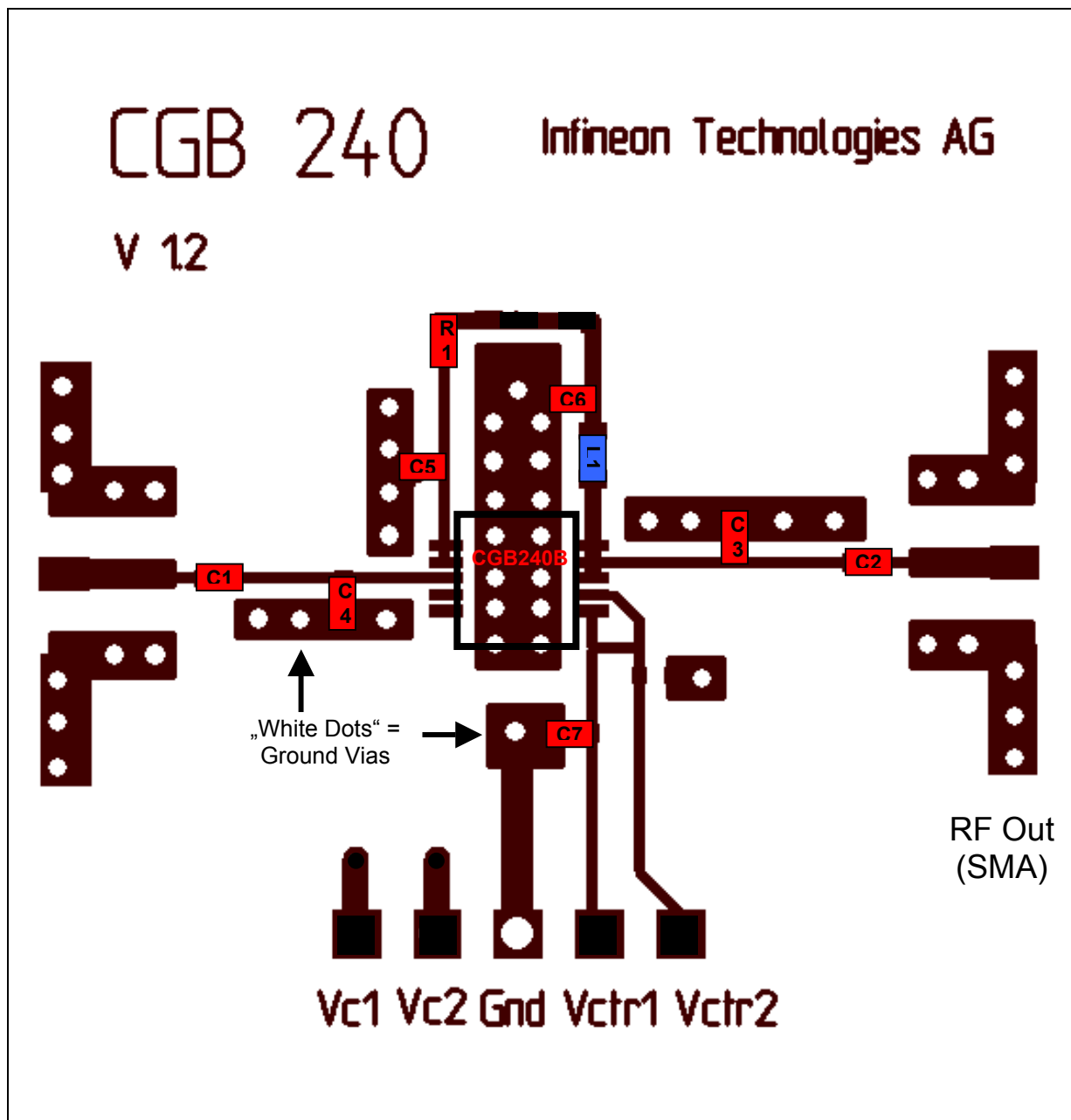

Figure 8 Layout of CGB240B evaluation board using TRL matching (see application note 2).

Vc1 and Vc2 are connected together on the PCB.

Vctr1 and Vctr2 are connected together on the PCB.

CGB240B Datasheet

Application Note 3: CGB240B as Bluetooth Power Amplifier using a Lumped Element Matching Concept

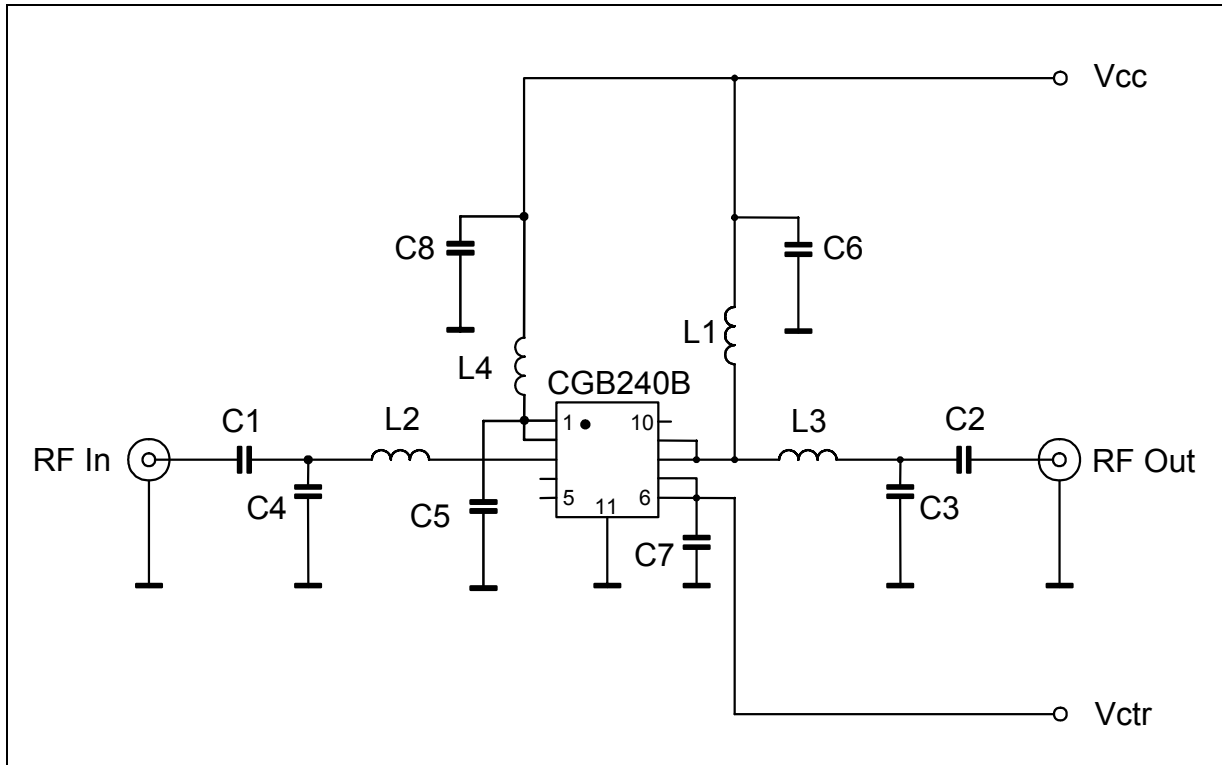

Figure 9 CGB240B Bluetooth amplifier using lumped element matching.

Part	Type	Value	Outline	Source	Part No.
C1	Cer. Capacitor	22 pF	0402	Murata COG	
C2	Cer. Capacitor	22 pF	0402	Murata COG	
C3	Cer. Capacitor	1.5 pF	0603	AVX ACCU-P	06035J1R5BBT
C4	Cer. Capacitor	2.0 pF	0402	Murata COG	
C5	Cer. Capacitor	82 pF	0402	Murata COG	
C6	Cer. Capacitor	0.1 μ F	0603	Murata X7R	
C7	Cer. Capacitor	1 nF	0402	Murata X7R	
C8	Cer. Capacitor	0.1 μ F	0603	Murata X7R	
L1	Inductor	22 nH	0603	Toko	LL1005-FH22NJ
L2	Inductor	1.0 nH	0402	Coilcraft	0402CS-1N0X_BG
L3	Inductor	1.0 nH	0402	Coilcraft	0402CS-1N0X_BG
L4	Inductor	22 nH	0603	Toko	LL1005-FH22NJ
R1	Jumper	0 Ω	0402		

CGB 240

Infineon Technologies AG

V 12

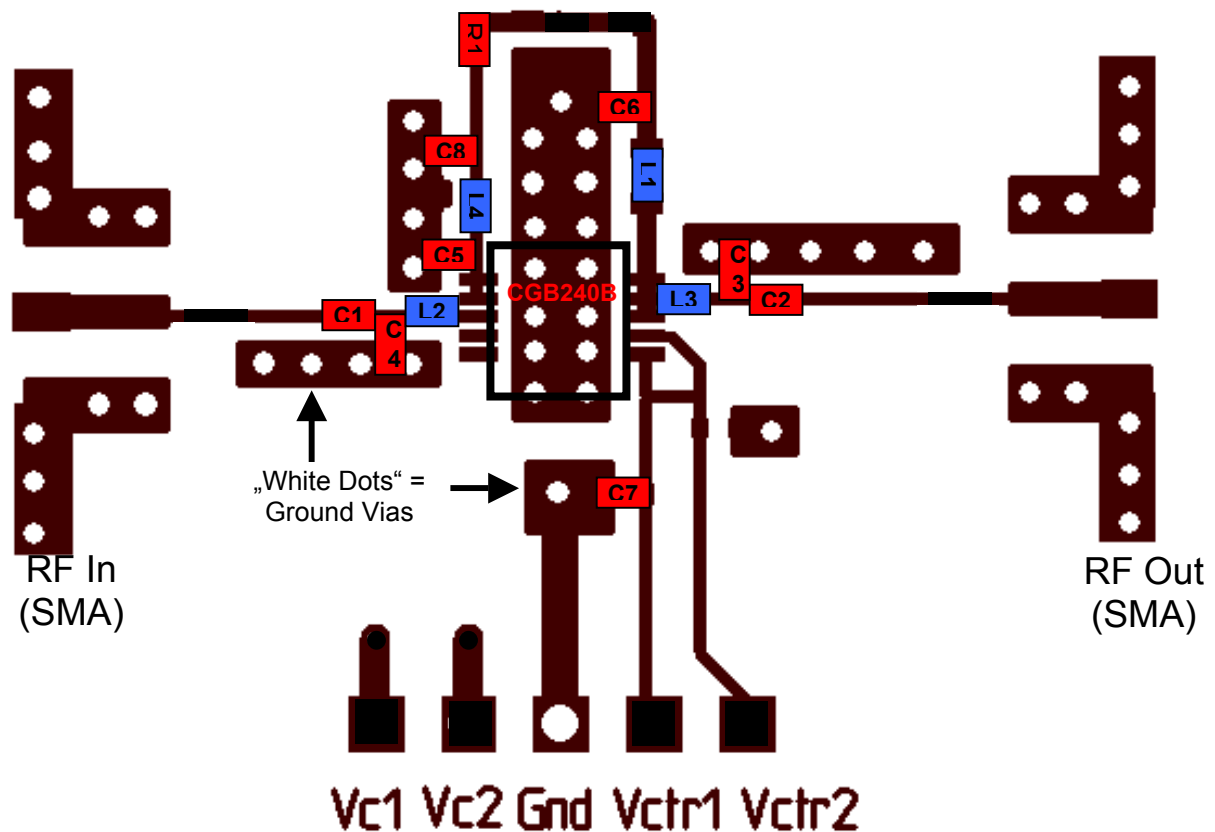

Figure 10 Bluetooth PA with lumped element matching (see application note 3).

A the discrete matching concept shown in figure 10 uses no transmission lines but only discrete components to provide device matching.

The use of a discrete matching concept saves PCB space and makes the design more tolerant towards variations of the PCB's ϵ_r , but will lead to a lower output power (typ. 0.3 dB lower) and higher BOM cost.

CGB240B Datasheet

Description of P-TSSOP-10-2 Package

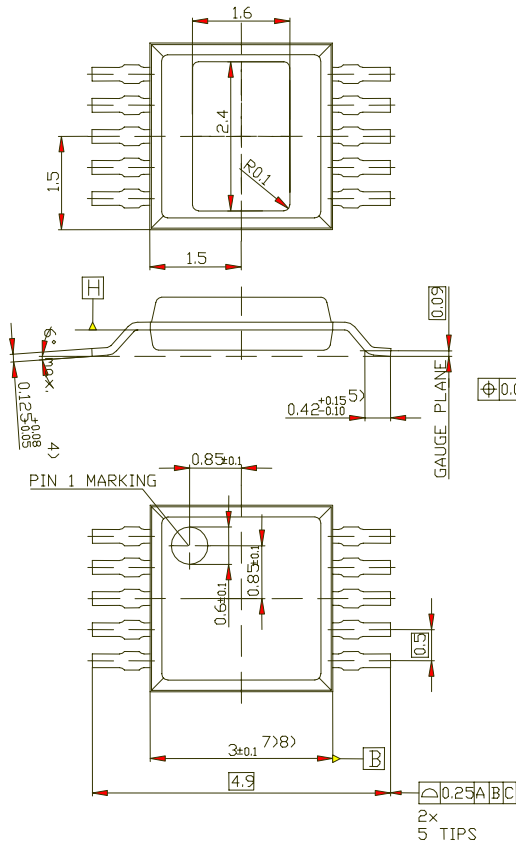

1. ALL DIMENSIONS IN MILLIMETER
 2. DIMENSIONING AND TOLERANCING PER ASME Y14.5M - 1994
 - 3) DIMENSION 3±0.1 DOES NOT INCLUDE MOLD FLASH, PROTRUSIONS OR GATE BURRS. MOLD FLASH, PROTRUSIONS OR GATE BURRS SHALL NOT EXCEED 0.15 PER SIDE
 - 4) DIMENSIONS OF LEADS APPLY TO PLATED LEADS
- SOLDERING
- 6) DATUMS B AND C TO BE DETERMINED AT DATUM PLANE H
 - 7) DIMENSION DOES NOT INCLUDE INTERLEAD FLASH OR PROTRUSION. INTERLEAD FLASH OR PROTRUSION SHALL NOT EXCEED 0.25 PER SIDE
 - 8) DIMENSIONS TO BE DETERMINED AT DATUM PLANE H

Footprint 20:1

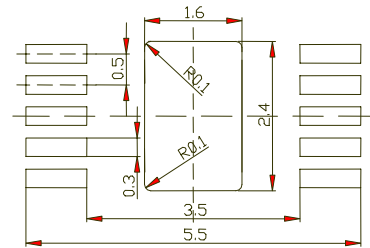

02 Official start drawing					
RevChange					
Proprietary data, Drawing according to		Company confidential, ISO 9015		Scale 20:1	
All rights reserved.		General tolerances			
		Date: 30.11.98		Format	
		Name: Mark		PACKAGE OUTLINE	
		CPD AIT DS		P-TSSOP-10-2	
02 N99C63A07		16.09.99 STA		Infinion Technologies	
RevChange		Date		Name	
Vendor No.		ISS-Name		Page	
		X63069-B		C63060-A2134-A002-02-0027	

In order to ensure maximum mounting yield and optimal reliability, special soldering conditions apply in volume production. Please ask for our information brochure on details or download the related document (TSSOP10_Soldering_Version01.pdf) from our website.

The P-TSSOP-10-2 is a level 3 package. International standards for handling this type of package are described in the JEDEC standard J-STD-033 „STANDARD FOR HANDLING, PACKING, SHIPPING AND USE OF MOISTURE/REFLOW SENSITIVE SURFACE-MOUNT DEVICES“, published May-1999. The original document is available from the JEDEC website www.jedec.org.

MSL Rating: 1/260C
Pb Free

CGB240B Datasheet

Part Marking:

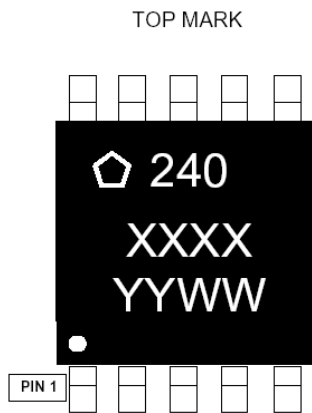

WHITE INK OR LASER MARK .

Line 1: (pentagon symbol) + 240

Line 2: XXXX = TriQuint assembly lot number

Line 3: YYWW = Year and Work Week

Part Orientation on Reel:

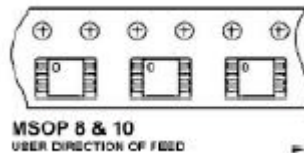

Ordering Information:

Type	Marking	Ordering Code	Package
CGB240B	CGB240B	t.b.d.	P-TSSOP-10-2

ESD: Electrostatic discharge sensitive device
Observe handling precautions!

CGB240B Datasheet

Published by TriQuint Semiconductor GmbH, Marketing, Konrad-Zuse-Platz 1, D-81829 Munich.

copyright TriQuint Semiconductor GmbH 2003. All Rights Reserved.

As far as patents or other rights of third parties are concerned, liability is only assumed for components per se, not for applications, processes and circuits implemented within components or assemblies.

The information describes the type of component and shall not be considered as assured characteristics.

Terms of delivery and rights to change design reserved.

For questions on technology, delivery, and prices please contact the Offices of TriQuint Semiconductor in Germany or the TriQuint Semiconductor Companies and Representatives worldwide.

Due to technical requirements components may contain dangerous substances. For information on the type in question please contact your nearest TriQuint Semiconductors Office.
