

AN2101FH

Single chip, analog signal processor IC for CCD camera

■ Overview

The AN2101FH is a single chip IC optimal to process the video signal of a CCD camera, incorporating a luminance signal processor and an encoder. With built-in DACs (8-bit: 18-ch) for adjustment, various adjustments and controls are done with serial data.

■ Features

- For 510H (250000 pixels) CCD
- Applicable for both NTSC and PAL
- Y-LPF built in
- Adjustment-use DAC (8-bit: 18-ch) built in
- Iris γ built in

■ Applications

- A variety of CCD cameras such as video camera, surveillance camera, board camera, TV phone, TV conference system, input camera for PC, etc.

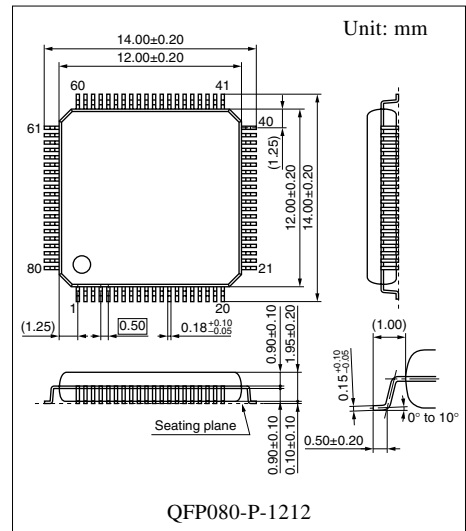

Note) The package of this product will be changed to lead-free type (QFP080-P-1212A). See the new package dimensions section later of this datasheet.

■ Block Diagram

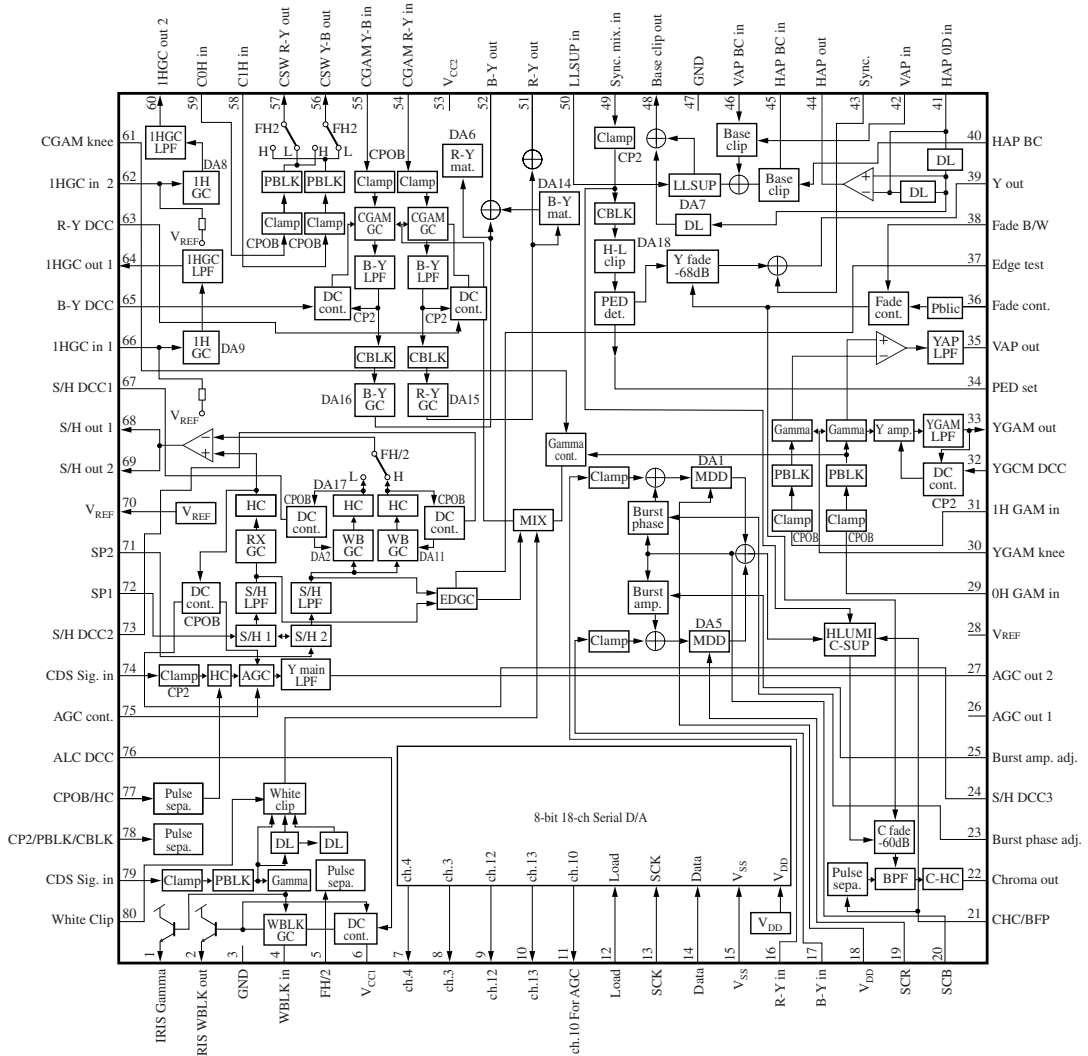

■ Pin Descriptions

Pin No.	Description	Pin No.	Description
1	IRIS GAM out	10	DAC output ch.1
2	IRIS WBLK out	11	DAC output ch.12
3	GND1	12	Load input
4	WBLK input	13	SCK input
5	FH/2 input	14	Data input
6	V _{CC1}	15	V _{SS}
7	DAC output ch.4	16	R-Y in
8	DAC output ch.3	17	B-Y in
9	DAC output ch.2	18	V _{DD}

■ Pin Descriptions (continued)

Pin No.	Description	Pin No.	Description
19	SCR	50	Luminance signal detection input (LLSUP)
20	SCB	51	R-Y out
21	BFP input/high colorfulness chroma clip setting	52	B-Y out
22	Chroma output	53	V _{CC2}
23	Burst phase setting	54	CGAM R-Y in
24	S/H DC stabilizing capacitance 3	55	CGAM Y-B in
25	Burst amplitude setting	56	CSW Y-B out
26	AGC out 1	57	CSW R-Y out
27	AGC out 2	58	C1H in
28	V _{REF} in (direct connection to pin 70)	59	C0H in
29	Luminance 0H in	60	Delay signal amp. output 2
30	Luminance gamma knee	61	Color difference gamma Knee
31	Luminance 1H in	62	Delay signal amp. input 2
32	Luminance gamma DC stabilizing capacitance	63	R-Y DC stabilizing capacitance
33	Luminance gamma output	64	Delay signal amp. output 1
34	Pedestal setting	65	B-Y DC stabilizing capacitance
35	V aperture output	66	Delay signal amp. input 1
36	Fade setting	67	S/H DC stabilizing capacitance 1
37	Edge test	68	S/H WB output 1
38	Fade level setting	69	S/H WB output 2
39	Luminance signal output	70	V _{REF} output
40	H aperture coring setting	71	SP2 input
41	H aperture generating circuit	72	SP1 input
42	V aperture coring setting	73	S/H DC stabilizing capacitance 2
43	Sync. input	74	CDS signal in (main)
44	H aperture output	75	AGC control
45	H aperture coring input	76	ALC DC stabilizing capacitance
46	V aperture coring input	77	CPOB input/luminance high cut setting
47	GND 2	78	CP2 / PBLK / CBLK input
48	Luminance contour correction output	79	CDS signal in (ALC)
49	Luminance sync. Mix. in	80	Color difference white clip setting

■ Absolute Maximum Ratings

Parameter	Symbol	Rating	Unit
Supply voltage	V_{CC}	5.5	V
Supply current	I_{CC}	130	mA
Power dissipation *2	P_D	360	mW
Operating ambient temperature *1	T_{opr}	-20 to +70	°C
Storage temperature *1	T_{stg}	-55 to +125	°C

Note) *1: Except for the operating ambient temperature and storage temperature, all ratings are for $T_a = 25^\circ\text{C}$.

*2: The power dissipation shown is the value for $T_a = 70^\circ\text{C}$.

■ Recommended Operating Range

Parameter	Symbol	Range	Unit
Supply voltage	V_{CC}	4.3 to 5.1	V

■ Electrical Characteristics at $T_a = 25^\circ\text{C}$

Parameter	Symbol	Conditions	Min	Typ	Max	Unit
Circuit current	I_{TOT}	$V_{CC} = 4.4\text{ V}$	66	90	114	mA
Reference voltage 1	V_{REF}	$V_{CC} = 4.4\text{ V}$	1.50	1.60	1.70	V
Reference voltage 2	V_{DD}	$V_{CC} = 4.4\text{ V}$	3.30	3.40	3.50	V
Pulse separation CPOB	V_{CPOB}	$V_{CC} = 4.4\text{ V}$	2.90	3.20	3.50	V
Pulse separation PBLK	V_{PBLK}	$V_{CC} = 4.4\text{ V}$	1.45	1.75	2.05	V
Pulse separation CP2	V_{CP2}	$V_{CC} = 4.4\text{ V}$	2.60	2.80	3.10	V
Pulse separation CBLK	V_{CBLK}	$V_{CC} = 4.4\text{ V}$	0.75	1.05	1.35	V
Pulse separation FH/2	V_{FH2}	$V_{CC} = 4.4\text{ V}$	1.00	1.30	1.60	V
Pulse separation Sync.	V_{SYNC}	$V_{CC} = 4.4\text{ V}$	0.80	1.10	1.40	V
Pulse separation BFP	V_{BEP}	$V_{CC} = 4.4\text{ V}$	3.10	3.40	3.70	V
Pulse separation SP1	V_{SP1}	$V_{CC} = 4.4\text{ V}$	0.20	0.50	0.80	V
Pulse separation SP2	V_{SP2}	$V_{CC} = 4.4\text{ V}$	0.20	0.50	0.80	V
AGC maximum gain	G_{AG1}	$V_{74} = 10\text{ stair step, } 50\text{ mV[p-p]}$	21.5	23.5	27.5	dB
AGC minimum gain	G_{AG2}	$V_{74} = 10\text{ stair step, } 1\,200\text{ mV[p-p]}$	-4.5	-2.0	0.5	dB
WB characteristics 1	V_{SH2}	$V_{74} = \text{sine wave } 500\text{ kHz, } 500\text{ mV[p-p]}$	270	400	530	mV[p-p]
WB characteristics 2	V_{SH7}	$V_{74} = \text{sine wave } 500\text{ kHz, } 500\text{ mV[p-p]}$	270	400	530	mV[p-p]
S/H characteristics 1	V_{SH9}	$V_{74} = \text{square wave } 500\text{ kHz, } 1\text{V[p-p]}$	430	630	830	mV[p-p]
S/H characteristics 2	V_{SH10}	$V_{74} = \text{square wave } 500\text{ kHz, } 1\text{V[p-p]}$	510	710	910	mV[p-p]
WB FH 2-step adjustment	V_{SHF}	$V_{74} = C - GND$	-6	0	6	mV[p-p]
Iris GC characteristic	V_{IR2}	$V_{79} = 10\text{ stair step, } 1\,200\text{ mV[p-p]}$	580	780	980	mV[p-p]
Iris gate step	V_{WG}	$V_{79} = C - GND$	-20	0	20	mV[p-p]
Iris gamma 1	V_{IG1}	$V_{79} = 10\text{ stair step, } 1\,500\text{ mV[p-p]}$	320	420	520	mV[p-p]
Iris gamma 2	G_{IG2}	$V_{79} = 10\text{ stair step, } 1\,500\text{ mV[p-p]}$	2.0	3.5	5.0	dB

■ Electrical Characteristics at $T_a = 25^\circ\text{C}$ (continued)

Parameter	Symbol	Conditions	Min	Typ	Max	Unit
Iris gamma 3	G_{IG3}	$V_{79} = 10$ stair step, 1 500 mV[p-p]	4.0	5.5	—	dB
Iris BLK step difference	V_{WB}	$V_{79} = C - \text{GND}$	-20	0	20	mV[p-p]
Delay signal amp gain 1	G_{IH2}	$V_{66} = \text{sine wave, 500 kHz, 500 mV[p-p]}$	6.5	8.5	—	dB
Delay signal amp gain 2	G_{IH5}	$V_{62} = \text{sine wave, 500 kHz, 500 mV[p-p]}$	6.5	8.5	—	dB
Luminance gamma characteristic 1	V_{YG1}	$V_{29} = 10$ stair step, 700 mV[p-p]	450	550	650	mV[p-p]
Luminance gamma characteristic 2	G_{YG2}	$V_{29} = 10$ stair step, 700 mV[p-p]	-13	-11	-9	dB
Luminance gamma characteristic 3	G_{YG3}	$V_{29} = 10$ stair step, 1 500 mV[p-p]	2.0	4.0	6.0	dB
Luminance gamma BLK stage	V_{YGB}	$V_{29} = C - \text{GND}$	-20	0	20	mV[p-p]
V aperture gain	V_{VA1}	$V_{31} = \text{sine wave, 500 kHz, 300 mV[p-p]}$	-1 350	-1 150	-950	mV[p-p]
V aperture BLK step difference	V_{VAB}	$V_{29} = V_{31} = C - \text{GND}$	-20	0	20	mV[p-p]
After this, at $V_{CC} = 5 \text{ V}$						
H aperture gain	V_{HA1}	$V_{49} = \text{sine wave, 4 MHz, 300 mV[p-p]}$	1 500	1 800	2 100	mV[p-p]
H aperture base clip	V_{HB2}	$V_{45} = \text{sine wave, 500 kHz, 100 mV[p-p]}$	0	30	60	mV[p-p]
V aperture base clip	V_{VB2}	$V_{46} = \text{sine wave, 500 kHz, 100 mV[p-p]}$	0	30	60	mV[p-p]
Luminance output amp gain	G_{Y1}	$V_{49} = 10$ stair step, 600 mV[p-p]	-1.5	0	1.5	dB
Luminance high clip level adjustment	V_{YH}	$V_{49} = 10$ stair step, 1V[p-p]	780	800	820	mV[p-p]
Luminance low clip level	V_{YL}	$V_{49} = 10$ stair step, -200 mV[p-p]	-40	-20	0	mV[p-p]
Synchronous signal output level	V_{YS}	$V_{49} = C - \text{GND}$	263	290	317	mV[p-p]
Pedestal control characteristic 1	V_{YP1}	$V_{49} = C - \text{GND}$	40	65	90	mV[p-p]
Pedestal control characteristic 2	V_{YP2}	$V_{49} = C - \text{GND}$	-30	-15	0	mV[p-p]
Luminance fade characteristic	G_{YFB}	$V_{49} = 10$ stair step, 600 mV[p-p]	—	-40	-26	dB
CSW(R-Y) gain	G_{CS1}	$V_{58} = V_{59} = 10$ stair step, 600 mV[p-p]	-1.5	0	1.5	dB
CSW(B-Y) gain	G_{CS2}	$V_{58} = V_{59} = 10$ stair step, 600 mV[p-p]	-1.5	0	1.5	dB
CSW(R-Y) BLK step difference	V_{CSB1}	$V_{58} = V_{59} = C - \text{GND}$	-20	0	20	mV[p-p]
CSW(B-Y) BLK step difference	V_{CSB2}	$V_{58} = V_{59} = C - \text{GND}$	-20	0	20	mV[p-p]
CSW(R-Y) BFH2 step difference	V_{CSF1}	$V_{58} = V_{59} = C - \text{GND}$	-20	0	20	mV[p-p]
CSW(B-Y) BFH2 step difference	V_{CSF2}	$V_{58} = V_{59} = C - \text{GND}$	-20	0	20	mV[p-p]
Color difference gamma characteristic 1	V_{CG1}	$V_{29} = 10$ stair step, 700 mV[p-p] $V_{54} = 10$ stair step, 350 mV[p-p]	170	230	290	mV[p-p]
Color difference gamma characteristic 2	G_{CG2}	$V_{29} = 10$ stair step, 700 mV[p-p] $V_{54} = 10$ stair step, 350 mV[p-p]	-12.5	-10.5	-8.5	dB
Color difference gamma characteristic 3	G_{CG3}	$V_{29} = 10$ stair step, 1 500 mV[p-p] $V_{54} = 10$ stair step, 750 mV[p-p]	1.0	2.5	4.0	dB
Color difference gamma characteristic 4	V_{CG4}	$V_{29} = 10$ stair step, 700 mV[p-p] $V_5 = 10$ stair step, 350 mV[p-p]	170	230	290	mV[p-p]
Color difference gamma characteristic 5	G_{CG5}	$V_{29} = 10$ stair step, 700 mV[p-p] $V_{55} = 10$ stair step, 350 mV[p-p]	-12.5	-10.5	-8.5	dB
Color difference gamma characteristic 6	G_{CG6}	$V_{29} = 10$ stair step, 1 500 mV[p-p] $V_{55} = 10$ stair step, 750 mV[p-p]	1.0	2.5	4.0	dB

■ Electrical Characteristics at $V_{CC} = 5\text{ V}$, $T_a = 25^\circ\text{C}$ (continued)

Parameter	Symbol	Conditions	Min	Typ	Max	Unit
After this, at $V_{CC} = 5\text{ V}$ (continued)						
Gamma control leak 1	V_{CGL1}	$V_{29} = 10$ stair step, 500 mV[p-p] $V_{55} = C - GND$	-70	0	70	mV[p-p]
Gamma control leak 2	V_{CGL2}	$V_{29} = 10$ stair step, 700 mV[p-p] $V_{54} = C - GND$	-70	0	70	mV[p-p]
R-Y gain characteristic	G_{CL1}	$V_{54} =$ sine wave, 500 kHz, 200 mV[p-p]	9.5	11.5	13.5	dB
B-Y gain characteristic	G_{CL3}	$V_{55} =$ sine wave, 500 kHz, 200 mV[p-p]	-1.5	0	1.5	dB
B-Y matrix characteristic	V_{CM1}	$V_{54} = 10$ stair step, 300 mV[p-p]	500	650	800	mV[p-p]
R-Y matrix characteristic	G_{CM2}	$V_{55} = 10$ stair step, 300 mV[p-p]	-2.0	0	2.0	dB
R-Y BLK step difference	V_{CB1}	$V_{54} = C - GND$	-20	0	20	mV[p-p]
B-Y BLK step difference	V_{CB2}	$V_{54} = C - GND$	-20	0	20	mV[p-p]
Burst level	V_{BU1}	$V_{16} =$ white 200 mV[p-p] $V_{17} = C - GND$	260	300	325	mV[p-p]
Chroma output amplitude (R)	G_{CR1}	$V_{16} =$ white 200 mV[p-p] $V_{17} = C - GND$	4.5	6.0	7.5	dB
Chroma output amplitude (B)	G_{CR3}	$V_{16} = C - GND$ $V_{17} =$ white 200 mV[p-p]	-0.5	1.0	2.5	dB
Chroma high cut characteristic 1	G_{CH1}	$V_{16} =$ white 400 mV[p-p] $V_{17} = C - GND$	7.0	8.5	10.0	dB
Chroma high cut characteristic 2	G_{CH2}	$V_{16} =$ white 400 mV[p-p] $V_{17} = C - GND$	7.0	8.5	10.0	dB
Chroma fade characteristic	G_{CF}	$V_{16} =$ white 200 mV[p-p] $V_{17} = C - GND$	—	-40	-20	dB
High luminance chroma suppress	G_{CS}	$V_{16} = V_{49} =$ white 500 V[p-p] $V_{17} = C - GND$	—	-40	-20	dB
Chroma BPF gain	G_{BPF1}	$V_{16} =$ sine wave, 4 MHz, 400 mV[p-p] $V_{17} = C - GND$	-4.5	-2.5	-0.5	dB
Color difference edge suppress	G_{EDGE}	$V_{54} =$ sine wave, 500kHz, 200 mV[p-p]	—	-40	-20	dB
Luminance LPF characteristic	—	$V_{74} =$ sine wave, 4.77 MHz, 500 mV[p-p]	—	—	-15	dB
S/H LPF characteristic	—	$V_{74} =$ sine wave, 3.5 MHz, 500 mV[p-p]	—	—	-15	dB
Luminance gamma LPF characteristic	—	$V_{29} =$ sine wave, 4.77 MHz, 300 mV[p-p]	—	—	-15	dB
V aperture LPF characteristic	—	$V_{31} =$ sine wave, 4.77 MHz, 300 mV[p-p]	—	—	-15	dB
Luminance white fade characteristic	—	$V_{49} = C - GND$	900	—	—	mV[p-p]
Color difference LPF characteristic	—	$V_{54} =$ sine wave, 3.5 MHz, 200 mV[p-p]	—	—	-15	dB
DAC External output 1	V_7	Data 00 to FF	0.4	to	3.3	V
DAC External output 2	V_8	Data 00 to FF	0.4	to	3.3	V
DAC External output 3	V_9	Data 00 to FF	0.4	to	3.3	V
DAC External output 4	V_{10}	Data 00 to FF	0.4	to	3.3	V
DAC External output 5	V_{11}	Data 00 to FF	0.4	to	3.3	V

• Pulse timing chart

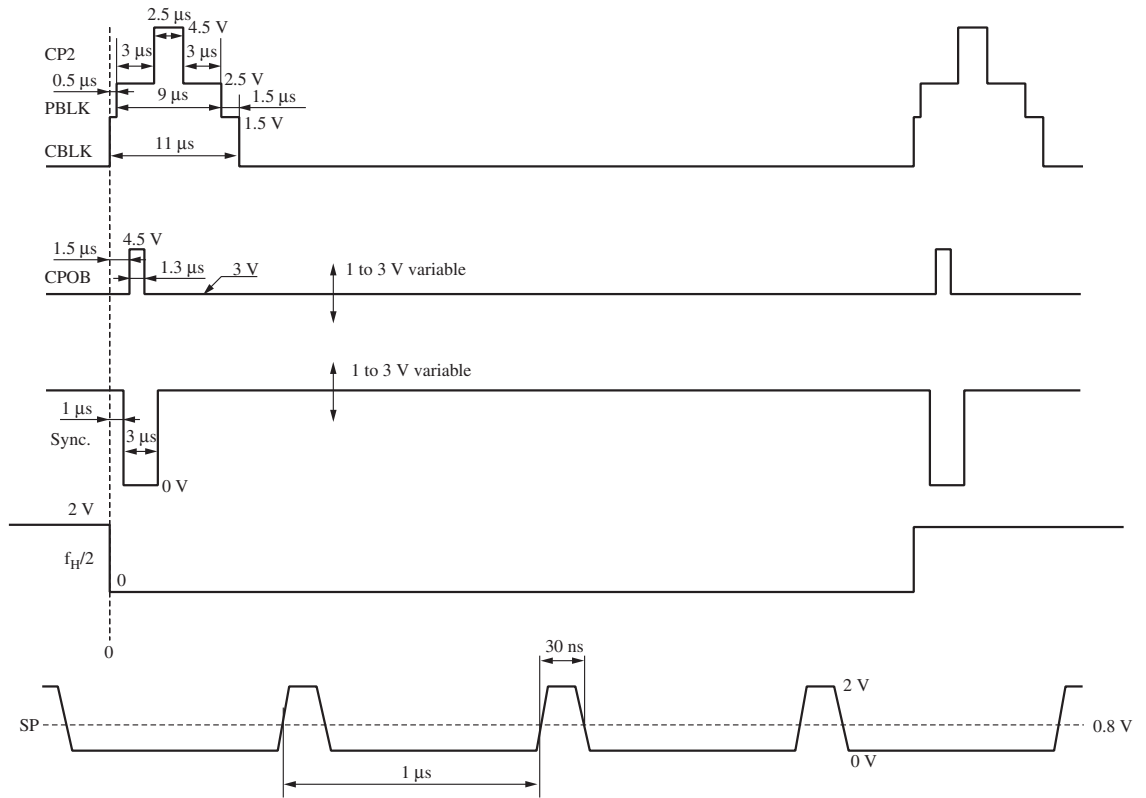

• DAC timing chart

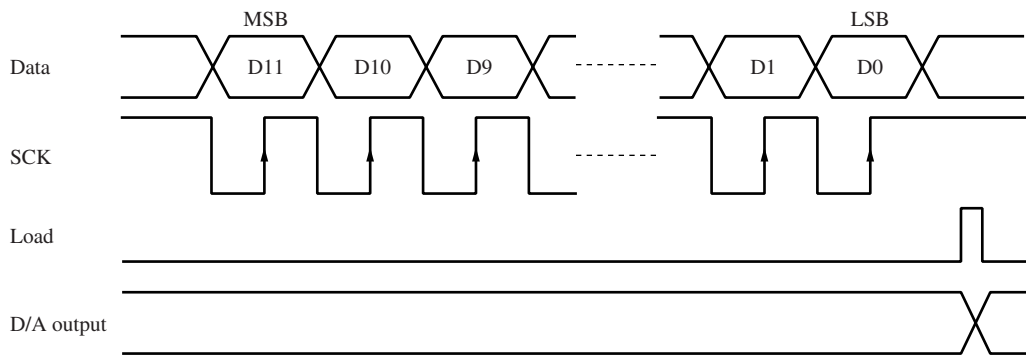

■ Terminal Equivalent Circuits

Pin No.	Symbol	Equivalent circuit	Description	Signal waveform
1	Iris γ output		<ul style="list-style-type: none"> • ALC γ Det. output • Output after BLK and γ-correction of the input signal from pin 79. • Output DC: 1.6 V 	
2	Iris gate output		<ul style="list-style-type: none"> • ALC γ Det. gate output • After doing BLK and γ-correction on the signal inputted to pin 79, the gated signal with WBLK is outputted. • Output DC: 1.6 V 	
3	GND	—	—	—
4	WBLK in		<ul style="list-style-type: none"> • Gate pulse input (gain control DC input) • Gates with pulse the input signal of pin 79 or controls with DC the gain of the input signal. 	
5	FH/2 in		<ul style="list-style-type: none"> • FH/2 pulse input • Threshold voltage: 1.3 V 	Refer to a timing chart
6	V_{CC1}	—	• typ. 4.5 V	DC
7	DA ch.4 output		• DA external output	

■ Terminal Equivalent Circuits (continued)

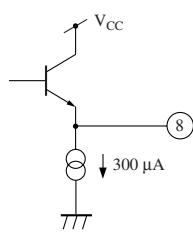
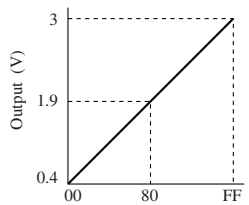
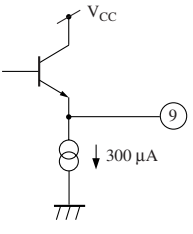
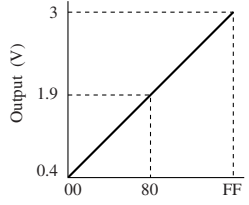
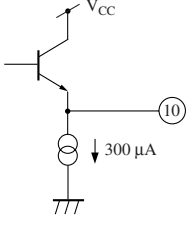
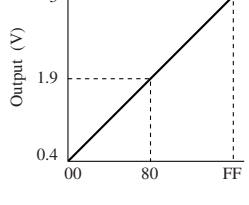
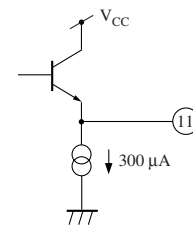
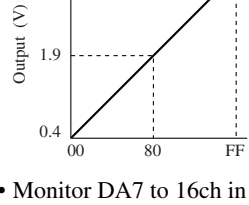
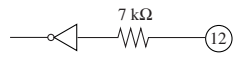
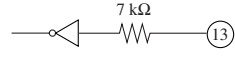
Pin No.	Symbol	Equivalent circuit	Description	Signal waveform
8	DA ch.3 output		<ul style="list-style-type: none"> DA external output 	
9	DA ch.2 output		<ul style="list-style-type: none"> DA external output 	
10	DA ch.1 output		<ul style="list-style-type: none"> DA external output 	
11	DA ch.12 output		<ul style="list-style-type: none"> DA external output GND for pin 77 in a test mode 	 <ul style="list-style-type: none"> Monitor DA7 to 16ch in a in a test mode
12	Load		<ul style="list-style-type: none"> Serial data latch pulse input Input impedance: 1 MΩ or more 	Refer to a DAC timing chart
13	Clock		<ul style="list-style-type: none"> Serial data shift clock input Input impedance: 1 MΩ or more 	Refer to a DAC timing chart

■ Terminal Equivalent Circuits (continued)

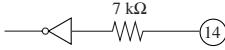
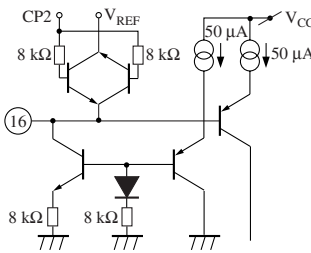
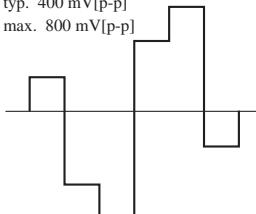
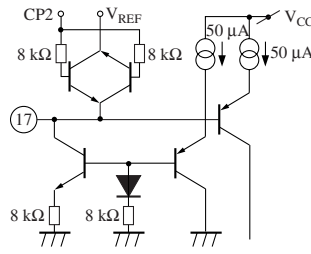
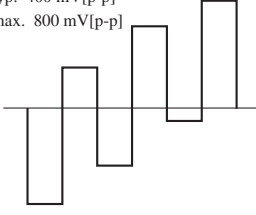
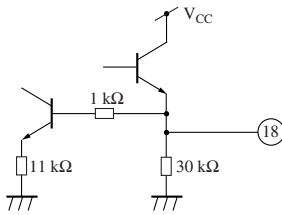
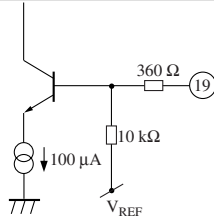
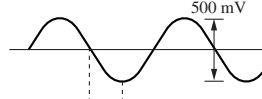
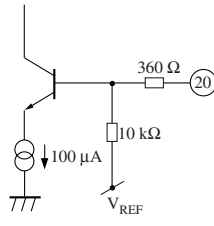
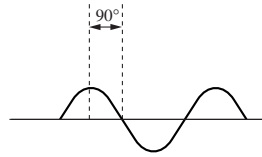
Pin No.	Symbol	Equivalent circuit	Description	Signal waveform
14	Data		<ul style="list-style-type: none"> Data input for serial data shift Input impedance: 1 MΩ or more 	Refer to a DAC timing chart
15	V _{SS}	—	• GND	
16	R-Y in		<ul style="list-style-type: none"> R-Y input (C coupling) If R-Y color differential signal outputted from pin 51 is inputted, the signal is clamped to V_{REF} and modulated to chroma signal. 	typ. 400 mV[p-p] max. 800 mV[p-p]  (At shooting a color-bar picture)
17	B-Y in		<ul style="list-style-type: none"> B-Y input (C coupling) If B-Y color differential signal outputted from pin 52 is inputted, the signal is clamped to V_{REF} and modulated to chroma signal. 	typ. 400 mV[p-p] max. 800 mV[p-p]  (At shooting a color-bar picture)
18	V _{DD}		<ul style="list-style-type: none"> Output DC: 3.4 V To be used as a power source for an internal CMOS block including DACs, etc. 	DC
19	SCR		<ul style="list-style-type: none"> Rch sub carrier input Modulates a color differential signal to a chroma signal, with a sub-carrier. 	NTSC 3.58 MHz (PAL 4.43 MHz) 
20	SCB		<ul style="list-style-type: none"> Bch sub carrier input Modulates a color differential signal to a chroma signal, with a sub-carrier. 	

■ Terminal Equivalent Circuits (continued)

Pin No.	Symbol	Equivalent circuit	Description	Signal waveform
21	CHC/BFP		<ul style="list-style-type: none"> Burst gate pulse input. Threshold: 3.3V Its timing is of the burst signal timing. Chroma clip setting input Sets a chroma suppress threshold for high luminance. 	
22	C-out		<ul style="list-style-type: none"> Chroma signal output Output DC: 1.6 V Output amplitude is clipped 2.5 times to a burst. 	
23	Burst phase setting		<ul style="list-style-type: none"> Burst phase setting NTSC; GND proximity PAL; V_{REF} proximity 	
24	S/H DCC3		<ul style="list-style-type: none"> DC control A.C. coupling 	
25	Burst level setting		<ul style="list-style-type: none"> Burst amplitude setting typ. V_{REF} 	

■ Terminal Equivalent Circuits (continued)

Pin No.	Symbol	Equivalent circuit	Description	Signal waveform
26	AGC out 1		<ul style="list-style-type: none"> Luminance AGC output 1 Output DC: 1.6 V Outputs, through AGC and LPF, a signal inputted to pin 74. (Input to 1HCCD.) 	<p>typ. 500 mV[p-p] (At shooting a color-bar picture)</p>
27	AGC out 2		<ul style="list-style-type: none"> Luminance AGC output 2 Output DC: 1.6 V Outputs, through AGC and LPF, a signal inputted to pin 74. (Input to pin 29.) 	<p>typ. 500 mV[p-p] (At shooting a color-bar picture)</p>
28	V _{REF} input	—	<ul style="list-style-type: none"> Connect to pin 70. DC: 1.6 V 	DC
29	0H GAM in		<ul style="list-style-type: none"> Luminance signal (0H) input Input the luminance signal outputted from pin 27. 	<p>typ. 500 mV[p-p] (At shooting a color-bar picture)</p>
30	Yγ knee		<ul style="list-style-type: none"> Luminance γ knee adjustment Sets the knee point for luminance γ-correction typ. open 	DC
31	1H GAN in		<ul style="list-style-type: none"> Luminance signal (1H) input Input, via 1HCCD, the luminance signal outputted from pin 26 after adjusting it to the same level as pin 27 output. 	<p>typ. 500 mV[p-p] (At shooting a color-bar picture)</p>

■ Terminal Equivalent Circuits (continued)

Pin No.	Symbol	Equivalent circuit	Description	Signal waveform
32	Y GAM DC		<ul style="list-style-type: none"> • DC control A.C. coupling • Clamps pin 33 output DC to V_{REF}. 	DC
33	Y GAM out		<ul style="list-style-type: none"> • Luminance gamma output • γ correction on the luminance signal inputted to pin 29. Then clamps the output DC to V_{REF} and outputs it. 	
34	PED set		<ul style="list-style-type: none"> • Pedestal level setting <p>NTSC: Approx. 50 mV PAL: Approx. 0 mV</p>	
35	VAP out		<ul style="list-style-type: none"> • Vertical contour correction signal output • Forms a vertical contour correction signal from the luminance signals of 0H and 1H inputted to pins 29 and pin 31, and outputs it. 	
36	Fade cont.		<ul style="list-style-type: none"> • Fade control • Fading out (in) setting for the luminance and chroma signals. 	

■ Terminal Equivalent Circuits (continued)

Pin No.	Symbol	Equivalent circuit	Description	Signal waveform
37	Edge test		<ul style="list-style-type: none"> • Edge signal detection • Output for testing 	<p>1MHz edge-full-wave rectified voltage</p>
38	Fade B/W		<ul style="list-style-type: none"> • Black and white fade changeover • Fade out level setting From black to white (0 mV[p-p] to 800 mV[p-p]) 	<p>Output mV</p> <p>1000</p> <p>500</p> <p>1 1.5 2 (38) [V]</p>
39	Y out		<ul style="list-style-type: none"> • Luminance signal output • Outputs the luminance signal inputted to pin 49 after high clip, low clip, pedestal setting and sync. mix. 	<p>Signal typ. 716 mV</p> <p>Sync. 286 mV</p>
40	HAP BC		<ul style="list-style-type: none"> • Horizontal contour correction noise rejection setting • Reduces the noise component of the horizontal contour correction signal inputted to pin 45. 	<p>(48) Output mV</p> <p>150</p> <p>-150</p> <p>-300 -100 100 300 Input mV</p> <p>(40) = 1.8 V</p>
41	HAP 0D in		<ul style="list-style-type: none"> • Horizontal contour correction signal input • Input the luminance signal outputted from pin 33. 	<p>Output mV log</p> <p>650</p> <p>200</p> <p>10 70 100 500 1000 Input mV log</p>

■ Terminal Equivalent Circuits (continued)

Pin No.	Symbol	Equivalent circuit	Description	Signal waveform
42	VAP BC		<ul style="list-style-type: none"> Vertical contour correction noise rejection setting To reduce the noise component of the vertical contour correction signal inputted to pin 46. 	
43	Sync.		<ul style="list-style-type: none"> Sync. pulse input threshold: 1.2 V 	Refer to a timing chart
44	HAP out		<ul style="list-style-type: none"> Horizontal contour correction signal output Forms the horizontal contour correction signal from the luminance signal inputted to pin 41 and pin 42. Then, outputs it. 	
45	HAP BC in		<ul style="list-style-type: none"> Horizontal contour correction signal input Input the horizontal contour correction signal outputted from pin 44. 	
46	VAP BC in		<ul style="list-style-type: none"> Vertical contour correction signal input Input the vertical contour correction signal outputted from pin 35. 	
47	GND	—	—	—

■ Terminal Equivalent Circuits (continued)

Pin No.	Symbol	Equivalent circuit	Description	Signal waveform
48	Base clip out		<ul style="list-style-type: none"> Luminance output with a contour correction Mixes the horizontal and vertical contour correction signals inputted to pin 45 and pin 46 with the noise-reduced luminance signal. Then output it. 	
49	Sync. mix in		<ul style="list-style-type: none"> Luminance signal input with a contour correction Input the luminance signal outputted from pin 48. 	
50	LLSUP in		<ul style="list-style-type: none"> Luminance detection signal input Input the DC which is made from integrating a luminance signal, so as to suppress the horizontal and vertical contour correction signals at a low luminance level. 	
51	R-Y out		<ul style="list-style-type: none"> Color difference (R-Y) output The R-Y color difference signal inputted to pin 54 is outputted after γ-correction, LPF and color phase correction. Input to pin 16. 	<p>typ. 400 mV[p-p] max. 800 mV[p-p]</p> <p>(At shooting a color-bar picture)</p>

Terminal Equivalent Circuits (continued)

Pin No.	Symbol	Equivalent circuit	Description	Signal waveform
52	B-Y out		<ul style="list-style-type: none"> Color difference (B-Y) output The B-Y color difference signal inputted to pin 55 is outputted after γ-correction, LPF and color phase correction. 	<p>typ. 400 mV[p-p] max. 800 mV[p-p]</p> <p>(At shooting a color-bar picture)</p>
53	V _{CC2}	—	<ul style="list-style-type: none"> typ. 4.5 V 	DC
54	CGAMR-Y in		<ul style="list-style-type: none"> Color difference (R-Y) gamma input Input the R-Y color difference signal outputted from pin 57. 	<p>typ. 400 mV[p-p] max. 800 mV[p-p] (Before γ-correction)</p> <p>(At shooting a color-bar picture)</p>
55	CGAMY-B in		<ul style="list-style-type: none"> Color difference (Y-B) gamma input Input the Y-B color difference signal outputted from pin 56. 	<p>typ. 400 mV[p-p] max. 800 mV[p-p] (Before γ-correction)</p> <p>(At shooting a color-bar picture)</p>
56	CSW Y-B out		<ul style="list-style-type: none"> Simultaneous output (Y-B) Outputs the color difference line sequential signal inputted to pin 58 and pin 59 as a Y-B color difference signal by $f_H/2$ pulse. 	
57	CSW R-Y out		<ul style="list-style-type: none"> Simultaneous output (R-Y) Outputs the color difference line sequential signal inputted to pin 58 and pin 59 as a R-Y color difference signal by $f_H/2$ pulse. 	

■ Terminal Equivalent Circuits (continued)

Pin No.	Symbol	Equivalent circuit	Description	Signal waveform
58	C1H in		<ul style="list-style-type: none"> • Simultaneous input (C1H) • Input the color difference line sequential signal from pin 60 after a 1HCCD gain adjustment. 	
59	C0H in		<ul style="list-style-type: none"> • Simultaneous input (C0H) • Input the color difference line sequential signal outputted from pin 68. 	
60	1HGC out 2		<ul style="list-style-type: none"> • CCD DL gain control output 2 • If the line sequential color differential signal outputted from pin 68 is inputted through a 1HCCD to pin 62, the same level signal as pin 69 output is outputted. 	
61	C gamma knee		<ul style="list-style-type: none"> • Color difference γ-knee adjustment • Sets the knee point for color difference γ-correction. typ. open 	DC
62	1HGC in 2		<ul style="list-style-type: none"> • CCD DL gain control input 2 • Input the color difference line sequential signal outputted from pin 68 via 1HCCD. 	

■ Terminal Equivalent Circuits (continued)

Pin No.	Symbol	Equivalent circuit	Description	Signal waveform
63	R-Y DCC		<ul style="list-style-type: none"> • DC control A.C. coupling • Clamps the R-Y color difference signal outputted from pin 51 to V_{REF} and then blanks it. 	DC
64	1HGC out 1		<ul style="list-style-type: none"> • CCD DL gain control input 1 • If the luminance signal outputted from pin 27 is inputted through a 1H-CCD to pin 66, the same level signal as pin 26 is outputted. 	Vertical aperture adjustment
65	B-Y DCC		<ul style="list-style-type: none"> • DC control A.C. coupling • Clamps the B-Y color difference signal outputted from pin 52 to V_{REF} and then blanks it. 	DC
66	1HGC in 1		<ul style="list-style-type: none"> • CCD DL gain control output 1 • Input the luminance signal outputted from pin 27 via 1HCCD. 	<p>(At shooting a color-bar picture)</p>
67	S/H DCC1		<ul style="list-style-type: none"> • DC control A.C. coupling 	DC

■ Terminal Equivalent Circuits (continued)

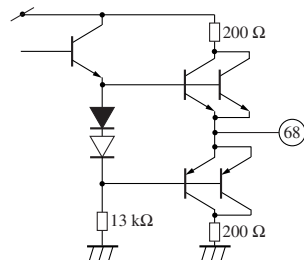
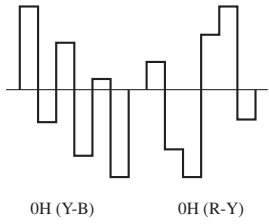
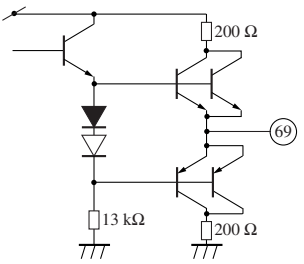
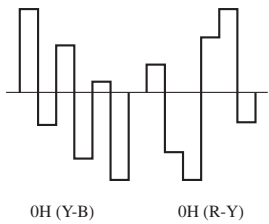
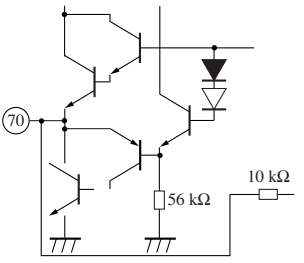
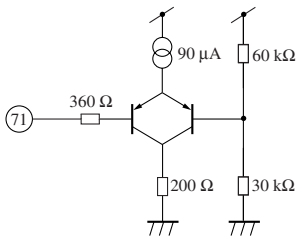
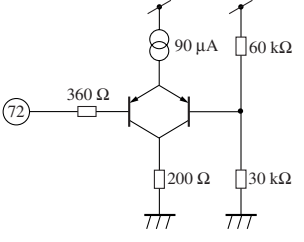
Pin No.	Symbol	Equivalent circuit	Description	Signal waveform
68	S/H out 1		<ul style="list-style-type: none"> • S/H output 1 • Carries out the color separation and white balance for the CDS signal inputted to pin 74, then outputs it. • Input to 1HCCD. 	
69	S/H out 2		<ul style="list-style-type: none"> • S/H output 2 • Outputs the same signal as pin 68 • Input it to pin 56 	
70	V _{REF}		<ul style="list-style-type: none"> • V_{REF} (1.6 V) output • Impedance: Approx. 1 Ω • Input this voltage to pin 28. 	DC
71	SP2		<ul style="list-style-type: none"> • Sampling pulse 2 input • Pulse threshold: 1 V 	Refer to a pulse timing
72	SP1		<ul style="list-style-type: none"> • Sampling pulse 1 input • Pulse threshold: 1 V 	Refer to a pulse timing

Terminal Equivalent Circuits (continued)

Pin No.	Symbol	Equivalent circuit	Description	Signal waveform
73	S/H DCC2		<ul style="list-style-type: none"> DC control A.C. coupling 	DC
74	CDS S-G in 1		<ul style="list-style-type: none"> CDS signal input 1 (AGC input) Clamp input of CDS signal 	
75	AGC cont.		<ul style="list-style-type: none"> AGC control voltage input 	
76	ALL DCC		<ul style="list-style-type: none"> DC control A.C. coupling Clamps ACC output to V_{REF} and gates it, then output it. 	DC
77	CPOB/HC		<ul style="list-style-type: none"> CPOB pulse input Threshold: 3.3 V CDS input high clip: typ. about $V_{REF} + 1.3 V$ 	

Terminal Equivalent Circuits (continued)

Pin No.	Symbol	Equivalent circuit	Description	Signal waveform
78	CP2/DBLK/ CBLK		<ul style="list-style-type: none"> • CP2 pulse input Threshold: 3 V • PBLK pulse input Threshold voltage: 1.8 V • CBLK pulse input Threshold voltage: 1.1 V 	
79	CDS S-G in 2		<ul style="list-style-type: none"> • CDS signal input 2 (ALC input) 	
80	White clip		<ul style="list-style-type: none"> • Color difference signal white clip DC setting • Sets the threshold voltage to clip the color differ- ence signal at a high lumi- nance level. 	

Cautions on Use

- Keep pin 36 (fade-in) lower than 0.5 V that is for a fade mode.
- Note that pin 12DA external output becomes a test mode for DA output used inside, if pin 77 voltage is set to (0 V).
- Be cautious in use because pin 29 static surge breakdown voltage level is low as compared with other pins.

Pin 29 breakdown level:

$$C = 200\text{PF} \quad +200\text{ V}$$

$$-230\text{ V to }-240\text{ V}$$

- A power rise timing should be considered somewhere around 15 ms.
If it differs much from it, it is likely to cause an abnormal operation.
- If you use this device without inputting a serial data, it is likely to cause an abnormal operation.

■ New Package Dimensions (Unit: mm)

- QFP080-P-1212A (Lead-free package)

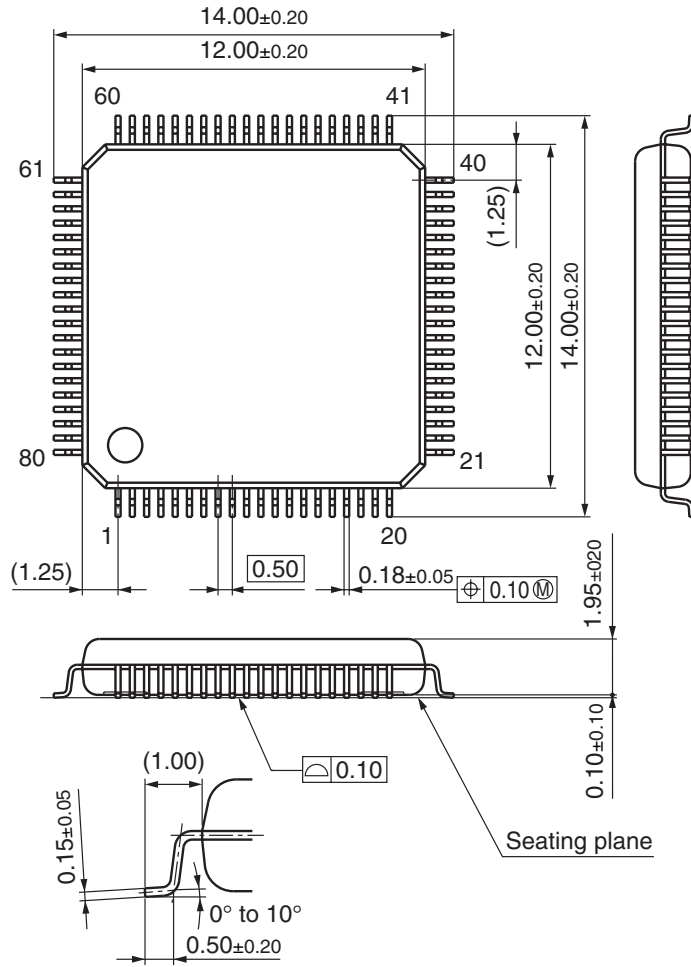

Request for your special attention and precautions in using the technical information and semiconductors described in this material

- (1) An export permit needs to be obtained from the competent authorities of the Japanese Government if any of the products or technologies described in this material and controlled under the "Foreign Exchange and Foreign Trade Law" is to be exported or taken out of Japan.
- (2) The technical information described in this material is limited to showing representative characteristics and applied circuit examples of the products. It does not constitute the warranting of industrial property, the granting of relative rights, or the granting of any license.
- (3) The products described in this material are intended to be used for standard applications or general electronic equipment (such as office equipment, communications equipment, measuring instruments and household appliances).
Consult our sales staff in advance for information on the following applications:
 - Special applications (such as for airplanes, aerospace, automobiles, traffic control equipment, combustion equipment, life support systems and safety devices) in which exceptional quality and reliability are required, or if the failure or malfunction of the products may directly jeopardize life or harm the human body.
 - Any applications other than the standard applications intended.
- (4) The products and product specifications described in this material are subject to change without notice for reasons of modification and/or improvement. At the final stage of your design, purchasing, or use of the products, therefore, ask for the most up-to-date Product Standards in advance to make sure that the latest specifications satisfy your requirements.
- (5) When designing your equipment, comply with the guaranteed values, in particular those of maximum rating, the range of operating power supply voltage and heat radiation characteristics. Otherwise, we will not be liable for any defect which may arise later in your equipment.
Even when the products are used within the guaranteed values, redundant design is recommended, so that such equipment may not violate relevant laws or regulations because of the function of our products.
- (6) When using products for which dry packing is required, observe the conditions (including shelf life and after-unpacking standby time) agreed upon when specification sheets are individually exchanged.
- (7) No part of this material may be reprinted or reproduced by any means without written permission from our company.

Please read the following notes before using the datasheets

- A. These materials are intended as a reference to assist customers with the selection of Panasonic semiconductor products best suited to their applications.
Due to modification or other reasons, any information contained in this material, such as available product types, technical data, and so on, is subject to change without notice.
Customers are advised to contact our semiconductor sales office and obtain the latest information before starting precise technical research and/or purchasing activities.
- B. Panasonic is endeavoring to continually improve the quality and reliability of these materials but there is always the possibility that further rectifications will be required in the future. Therefore, Panasonic will not assume any liability for any damages arising from any errors etc. that may appear in this material.
- C. These materials are solely intended for a customer's individual use.
Therefore, without the prior written approval of Panasonic, any other use such as reproducing, selling, or distributing this material to a third party, via the Internet or in any other way, is prohibited.