

UTCM2110 LINEAR INTEGRATED CIRCUIT

MONAURAL MIC AMP. FOR VIDEO CAMERA

DESCRIPTION

The UTC M2110 is a monaural microphone amplifier for video camera. It can operate from 2.7V.

The performance is low operating current and small package. Therefore it is easy to design the downsizing and low consumption.

FEATURES

*Operating Voltage: 2.7V~5.3V

*Low Operating Current: $V^+=5V$, 3.5mA (Typ.)

$V^+=3.3V$, 1.1mA (Typ.)

*Short Circuit Protection for External MIC.

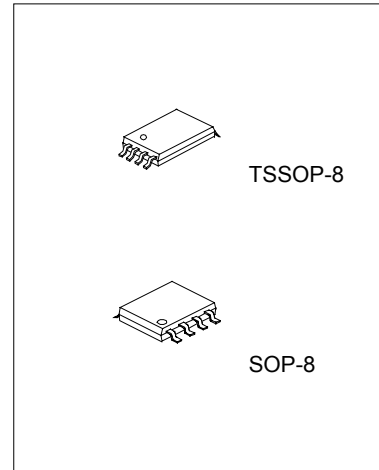

PIN CONFIGURATION

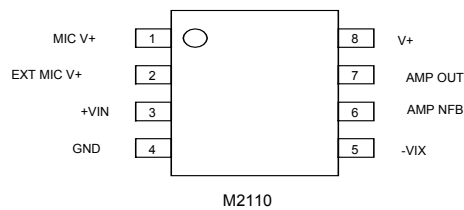

BLOCK DIAGRAM

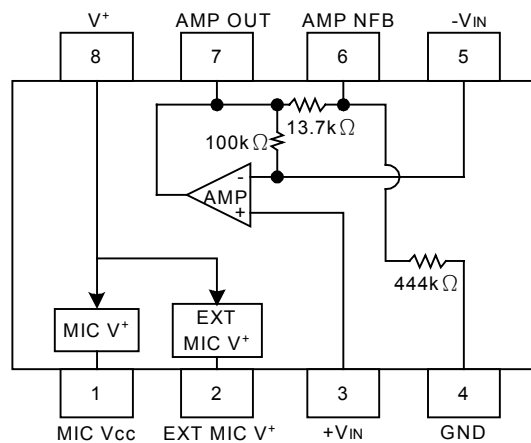

UTCM2110 LINEAR INTEGRATED CIRCUIT

UTC assumes no responsibility for equipment failures that result from using products at values that exceed, even momentarily, rated values (such as maximum ratings, operating condition ranges, or other parameters) listed in products specifications of any and all UTC products described or contained herein. UTC products are not designed for use in life support appliances, devices or systems where malfunction of these products can be reasonably expected to result in personal injury. Reproduction in whole or in part is prohibited without the prior written consent of the copyright owner. The information presented in this document does not form part of any quotation or contract, is believed to be accurate and reliable and may be changed without notice.