

# LM79XX

# LINEAR INTEGRATED CIRCUIT

## 3 TERMINAL 1A NEGATIVE VOLTAGE REGULATOR

### DESCRIPTION

The Contek LM79XX series of three-terminal negative regulators are available in TO-220 package and with several fixed output voltage, making them useful in a wide range of application. Each type employs internal current limiting, thermal shut-down and safe area protection, making it essentially indestructible.

### FEATURES

- \*Output current up to 1A
- \*-5V;-6V;-8V;-12V;-15V;-18V;-24V output voltage available
- \*Thermal overload protection
- \*Short circuit protection

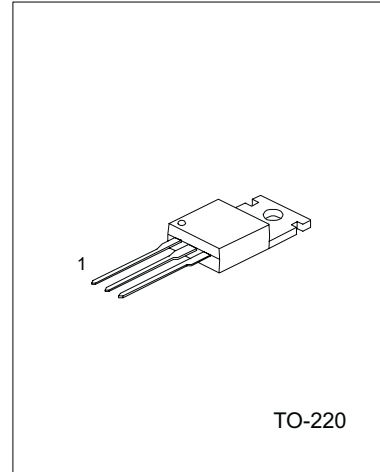

1:GND 2:Input 3:Output

### BLOCK DIAGRAM

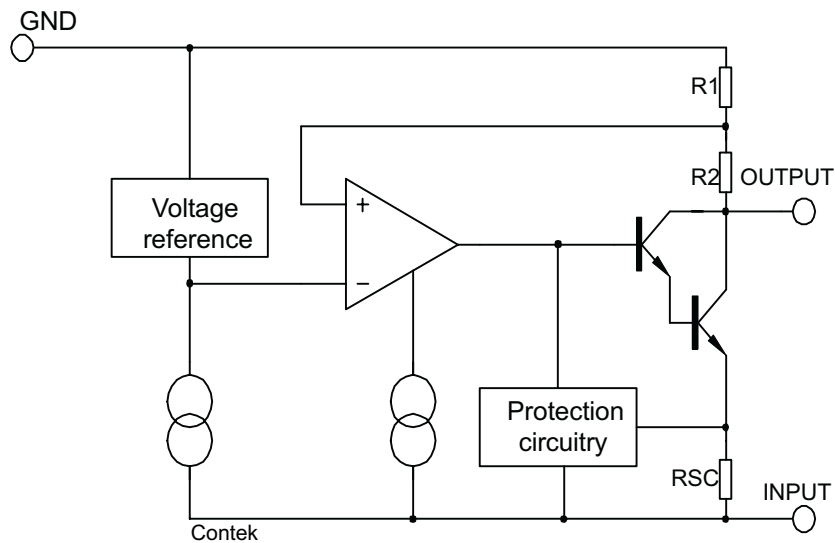

Contek Microelectronics Co.,Ltd.

<http://www.contek-ic.com> E-mail:sales@contek-ic.com

# LM79XX

# LINEAR INTEGRATED CIRCUIT

## ABSOLUTE MAXIMUM RATINGS(Ta=25 C)

PARAMETER	SYMBOL	VALUE	UNIT
Input voltage	$V_i$	-35	V
Thermal resistance junction-air	$R_{\theta JA}$	65	C /W
Thermal resistance junction-cases	$R_{\theta JC}$	5	C /W
Operating Temperature	$T_{opr}$	0 ~ +125	C
Storage Temperature	$T_{stg}$	-65 ~ +150	C

## Contek7905 ELECTRICAL CHARACTERISTICS

(Refer to test circuits,  $0 < T_j < 125$  C,  $I_o = 500mA$ ,  $V_i = -10V$ ,  $C_i = 33\mu F$ ,  $C_o = 1\mu F$ , unless otherwise specified)

PARAMETER	SYMBOL	TEST CONDITIONS	MIN	TYP	MAX	UNIT
Output voltage	$V_o$	$T_j = 25$ C	-4.8	-5.0	-5.2	V
		$5.0mA < I_o < 1.0A$ , $P_o < 15W$ $V_i = -7V$ to $-20V$	-4.75	-5.00	-5.25	V
Line regulation	$\Delta V_o$	$T_j = 25$ C, $V_i = -7V$ to $-25V$		10	100	mV
		$T_j = 25$ C, $V_i = -8V$ to $-12V$				mV
Load regulation	$\Delta V_o$	$T_j = 25$ C, $I_o = 5.0mA$ to $1.5A$		10	100	mV
		$T_j = 25$ C, $I_o = 250mA$ to $750mA$		3	50	mV
Quiescent current	$I_q$	$T_j = 25$ C		3	6	mA
Quiescent current change	$\Delta I_q$	$I_o = 5mA$ to $1.0A$		0.05	0.5	mA
		$V_i = -7V$ to $-25V$		0.1	1.3	mA
Output voltage drift	$\Delta V_o / \Delta T$	$I_o = 5mA$		-0.4		mV/ C
Output noise voltage	$V_N$	$f = 10Hz$ to $100kHz$ , $T_a = 25$ C		100		$\mu V$
Ripple rejection	RR	$f = 120Hz$ , $V_i = -8V$ to $-18V$	54	60		dB
Dropout voltage	$V_o$	$I_o = 1.0A$ , $T_j = 25$ C		2		V
Short circuit current	$I_{sc}$	$V_i = -35V$ , $T_a = 25$ C		300		mA
peak current	$I_{pk}$	$T_j = 25$ C		2.2		A

## Contek7906 ELECTRICAL CHARACTERISTICS

(Refer to test circuits,  $0 < T_j < 125$  C,  $I_o = 500mA$ ,  $V_i = -11V$ ,  $C_i = 2.2\mu F$ ,  $C_o = 1\mu F$ , unless otherwise specified)

PARAMETER	SYMBOL	TEST CONDITIONS	MIN	TYP	MAX	UNIT
Output voltage	$V_o$	$T_j = 25$ C	-5.75	-6.00	-6.25	V
		$5.0mA < I_o < 1.0A$ , $P_o < 15W$ $V_i = -8V$ to $-21V$	-5.7	-6.0	-6.3	V
Line regulation	$\Delta V_o$	$T_j = 25$ C, $V_i = -8V$ to $-25V$		10	120	mV
		$T_j = 25$ C, $V_i = -9V$ to $-13V$		5	60	mV
Load regulation	$\Delta V_o$	$T_j = 25$ C, $I_o = 5.0mA$ to $1.5A$		10	120	mV
		$T_j = 25$ C, $I_o = 250mA$ to $750mA$		3	60	mV
Quiescent current	$I_q$	$T_j = 25$ C		3	6	mA
Quiescent current change	$\Delta I_q$	$I_o = 5mA$ to $1.0A$			0.5	mA
		$V_i = -8V$ to $-25V$			1.3	mA
Output voltage drift	$\Delta V_o / \Delta T$	$I_o = 5mA$		-0.5		mV/ C
Output noise voltage	$V_N$	$f = 10Hz$ to $100kHz$ , $T_a = 25$ C		130		$\mu V$
Ripple rejection	RR	$f = 120Hz$ , $V_i = -9V$ to $-19V$	54	60		dB
Dropout voltage	$V_o$	$I_o = 1.0A$ , $T_j = 25$ C		2		V
Short circuit current	$I_{sc}$	$V_i = -35V$ , $T_a = 25$ C		300		mA
peak current	$I_{pk}$	$T_j = 25$ C		2.2		A



Contek Microelectronics Co.,Ltd.

<http://www.contek-ic.com> E-mail:sales@contek-ic.com

# LM79XX

# LINEAR INTEGRATED CIRCUIT

## Contek7908 ELECTRICAL CHARACTERISTICS

(Refer to test circuits,  $0 < T_j < 125$  C,  $I_o = 500\text{mA}$ ,  $V_i = -14\text{V}$ ,  $C_i = 2.2\mu\text{F}$ ,  $C_o = 1\mu\text{F}$ , unless otherwise specified)

PARAMETER	SYMBOL	TEST CONDITIONS	MIN	TYP	MAX	UNIT
Output voltage	$V_o$	$T_j = 25$ C	-7.7	-8.0	-8.3	V
		$5.0\text{mA} < I_o < 1.0\text{A}$ , $P_o < 15\text{W}$ $V_i = -10.5\text{V}$ to $-23\text{V}$	-7.6	-8.0	-8.4	V
Line regulation	$\Delta V_o$	$T_j = 25$ C, $V_i = -10.5\text{V}$ to $-25\text{V}$		10	100	mV
		$T_j = 25$ C, $V_i = -11.5\text{V}$ to $-17\text{V}$		5	80	mV
Load regulation	$\Delta V_o$	$T_j = 25$ C, $I_o = 5.0\text{mA}$ to $1.5\text{A}$		12	160	mV
		$T_j = 25$ C, $I_o = 250\text{mA}$ to $750\text{mA}$		4	80	mV
Quiescent current	$I_Q$	$T_j = 25$ C		3	6	mA
Quiescent current change	$\Delta I_Q$	$I_o = 5\text{mA}$ to $1.0\text{A}$		0.05	0.5	mA
		$V_i = -11.5\text{V}$ to $-25\text{V}$		0.1	1.0	mA
Output voltage drift	$\Delta V_o / \Delta T$	$I_o = 5\text{mA}$		-0.6		mV/ C
Output noise voltage	$V_N$	$f = 10\text{Hz}$ to $100\text{kHz}$ , $T_a = 25$ C		175		$\mu\text{V}$
Ripple rejection	RR	$f = 120\text{Hz}$ , $V_i = -11.5\text{V}$ to $-21.5\text{V}$	54	60		dB
Dropout voltage	$V_o$	$I_o = 1.0\text{A}$ , $T_j = 25$ C		2		V
Short circuit current	$I_{sc}$	$V_i = -35\text{V}$ , $T_a = 25$ C		300		mA
peak current	$I_{pk}$	$T_j = 25$ C		2.2		A

## Contek7912 ELECTRICAL CHARACTERISTICS

(Refer to test circuits,  $0 < T_j < 125$  C,  $I_o = 500\text{mA}$ ,  $V_i = -18\text{V}$ ,  $C_i = 2.2\mu\text{F}$ ,  $C_o = 1\mu\text{F}$ , unless otherwise specified)

PARAMETER	SYMBOL	TEST CONDITIONS	MIN	TYP	MAX	UNIT
Output voltage	$V_o$	$T_j = 25$ C	-11.5	-12.0	-12.5	V
		$5.0\text{mA} < I_o < 1.0\text{A}$ , $P_o < 15\text{W}$ $V_i = -14.5\text{V}$ to $-27\text{V}$	-11.4	-12	-12.6	V
Line regulation	$\Delta V_o$	$T_j = 25$ C, $V_i = -14.5\text{V}$ to $-30\text{V}$		12	240	mV
		$T_j = 25$ C, $V_i = -16\text{V}$ to $-22\text{V}$		6	120	mV
Load regulation	$\Delta V_o$	$T_j = 25$ C, $I_o = 5.0\text{mA}$ to $1.5\text{A}$		12	240	mV
		$T_j = 25$ C, $I_o = 250\text{mA}$ to $750\text{mA}$		4	120	mV
Quiescent current	$I_Q$	$T_j = 25$ C		3	6	mA
Quiescent current change	$\Delta I_Q$	$I_o = 5\text{mA}$ to $1.0\text{A}$		0.05	0.5	mA
		$V_i = -14.5\text{V}$ to $-30\text{V}$		0.1	1.0	mA
Output voltage drift	$\Delta V_o / \Delta T$	$I_o = 5\text{mA}$		-0.8		mV/ C
Output noise voltage	$V_N$	$f = 10\text{Hz}$ to $100\text{kHz}$ , $T_a = 25$ C		200		$\mu\text{V}$
Ripple rejection	RR	$f = 120\text{Hz}$ , $V_i = -15\text{V}$ to $-25\text{V}$	54	60		dB
Dropout voltage	$V_o$	$I_o = 1.0\text{A}$ , $T_j = 25$ C		2		V
Short circuit current	$I_{sc}$	$V_i = -35\text{V}$ , $T_a = 25$ C		300		mA
peak current	$I_{pk}$	$T_j = 25$ C		2.2		A



Contek Microelectronics Co.,Ltd.

<http://www.contek-ic.com> E-mail:sales@contek-ic.com

# LM79XX

# LINEAR INTEGRATED CIRCUIT

## Contek7915 ELECTRICAL CHARACTERISTICS

(Refer to test circuits,  $0 < T_j < 125$  C,  $I_o = 500\text{mA}$ ,  $V_i = -23\text{V}$ ,  $C_i = 2.2\mu\text{F}$ ,  $C_o = 1\mu\text{F}$ , unless otherwise specified)

PARAMETER	SYMBOL	TEST CONDITIONS	MIN	TYP	MAX	UNIT
Output voltage	$V_o$	$T_j = 25$ C	-14.4	-15.0	-15.6	V
		$5.0\text{mA} < I_o < 1.0\text{A}$ , $P_o < 15\text{W}$ $V_i = -17.5\text{V}$ to $-30\text{V}$	-14.25	-15	-15.75	V
Line regulation	$\Delta V_o$	$T_j = 25$ C, $V_i = -17.5\text{V}$ to $-30\text{V}$		12	300	mV
		$T_j = 25$ C, $V_i = -20\text{V}$ to $-26\text{V}$		6	150	mV
Load regulation	$\Delta V_o$	$T_j = 25$ C, $I_o = 5.0\text{mA}$ to $1.5\text{A}$		12	300	mV
		$T_j = 25$ C, $I_o = 250\text{mA}$ to $750\text{mA}$		4	150	mV
Quiescent current	$I_Q$	$T_j = 25$ C		3	6	mA
Quiescent current change	$\Delta I_Q$	$I_o = 5\text{mA}$ to $1.0\text{A}$		0.05	0.5	mA
		$V_i = -17.5\text{V}$ to $-30.5\text{V}$		0.1	1.0	mA
Output voltage drift	$\Delta V_o / \Delta T$	$I_o = 5\text{mA}$		-0.9		mV/ C
Output noise voltage	$V_N$	$f = 10\text{Hz}$ to $100\text{kHz}$ , $T_a = 25$ C		250		$\mu\text{V}$
Ripple rejection	RR	$f = 120\text{Hz}$ , $V_i = -18.5\text{V}$ to $-28.5\text{V}$	54	60		dB
Dropout voltage	$V_o$	$I_o = 1.0\text{A}$ , $T_j = 25$ C		2		V
Short circuit current	$I_{sc}$	$V_i = -35\text{V}$ , $T_a = 25$ C		300		mA
peak current	$I_{pk}$	$T_j = 25$ C		2.2		A

## Contek7918 ELECTRICAL CHARACTERISTICS

(Refer to test circuits,  $0 < T_j < 125$  C,  $I_o = 500\text{mA}$ ,  $V_i = -27\text{V}$ ,  $C_i = 2.2\mu\text{F}$ ,  $C_o = 1\mu\text{F}$ , unless otherwise specified)

PARAMETER	SYMBOL	TEST CONDITIONS	MIN	TYP	MAX	UNIT
Output voltage	$V_o$	$T_j = 25$ C	-17.3	-18.0	-18.7	V
		$5.0\text{mA} < I_o < 1.0\text{A}$ , $P_o < 15\text{W}$ $V_i = -21\text{V}$ to $-33\text{V}$	-17.1	-18	-18.9	V
Line regulation	$\Delta V_o$	$T_j = 25$ C, $V_i = -21\text{V}$ to $-33\text{V}$		15	360	mV
		$T_j = 25$ C, $V_i = -24\text{V}$ to $-30\text{V}$		8	180	mV
Load regulation	$\Delta V_o$	$T_j = 25$ C, $I_o = 5.0\text{mA}$ to $1.5\text{A}$		15	360	mV
		$T_j = 25$ C, $I_o = 250\text{mA}$ to $750\text{mA}$		5.0	180	mV
Quiescent current	$I_Q$	$T_j = 25$ C		3	6	mA
Quiescent current change	$\Delta I_Q$	$I_o = 5\text{mA}$ to $1.0\text{A}$			0.5	mA
		$V_i = -21\text{V}$ to $-32\text{V}$			1.0	mA
Output voltage drift	$\Delta V_o / \Delta T$	$I_o = 5\text{mA}$		-1		mV/ C
Output noise voltage	$V_N$	$f = 10\text{Hz}$ to $100\text{kHz}$ , $T_a = 25$ C		300		$\mu\text{V}$
Ripple rejection	RR	$f = 120\text{Hz}$ , $V_i = -22\text{V}$ to $-32\text{V}$	54	60		dB
Dropout voltage	$V_o$	$I_o = 1.0\text{A}$ , $T_j = 25$ C		2		V
Short circuit current	$I_{sc}$	$V_i = -35\text{V}$ , $T_a = 25$ C		300		mA
peak current	$I_{pk}$	$T_j = 25$ C		2.2		A



Contek Microelectronics Co.,Ltd.

<http://www.contek-ic.com> E-mail:sales@contek-ic.com

# LM79XX

# LINEAR INTEGRATED CIRCUIT

## Contek7924 ELECTRICAL CHARACTERISTICS

(Refer to test circuits,  $0 < T_j < 125$  C,  $I_o = 500\text{mA}$ ,  $V_i = -33\text{V}$ ,  $C_i = 2.2\mu\text{F}$ ,  $C_o = 1\mu\text{F}$ , unless otherwise specified)

PARAMETER	SYMBOL	TEST CONDITIONS	MIN	TYP	MAX	UNIT
Output voltage	$V_o$	$T_j = 25$ C	-23	-24	-25	V
		$5.0\text{mA} < I_o < 1.0\text{A}$ , $P_o < 15\text{W}$ $V_i = -27\text{V}$ to $-38\text{V}$	-22.8	-24	-25.2	V
Line regulation	$\Delta V_o$	$T_j = 25$ C, $V_i = -27\text{V}$ to $-38\text{V}$		15	480	mV
		$T_j = 25$ C, $V_i = -30\text{V}$ to $-36\text{V}$		8	240	mV
Load regulation	$\Delta V_o$	$T_j = 25$ C, $I_o = 5.0\text{mA}$ to $1.5\text{A}$		15	480	mV
		$T_j = 25$ C, $I_o = 250\text{mA}$ to $750\text{mA}$		5.0	240	mV
Quiescent current	$I_Q$	$T_j = 25$ C		3	6	mA
Quiescent current change	$\Delta I_Q$	$I_o = 5\text{mA}$ to $1.0\text{A}$			0.5	mA
		$V_i = -27\text{V}$ to $-38\text{V}$			1.0	mA
Output voltage drift	$\Delta V_o / \Delta T$	$I_o = 5\text{mA}$		-1		mV/ C
Output noise voltage	$V_N$	$f = 10\text{Hz}$ to $100\text{kHz}$ , $T_a = 25$ C		400		$\mu\text{V}$
Ripple rejection	RR	$f = 120\text{Hz}$ , $V_i = -28\text{V}$ to $-38\text{V}$	54	60		dB
Dropout voltage	$V_o$	$I_o = 1.0\text{A}$ , $T_j = 25$ C		2		V
Short circuit current	$I_{sc}$	$V_i = -35\text{V}$ , $T_a = 25$ C		300		mA
peak current	$I_{pk}$	$T_j = 25$ C		2.2		A

## APPLICATION CIRCUITS

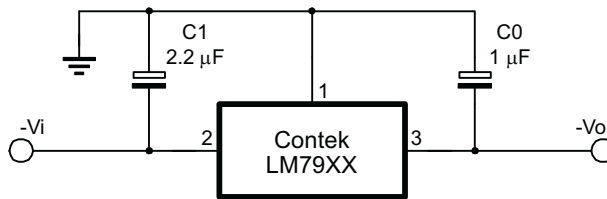

Fig.1 Fixed output regulator

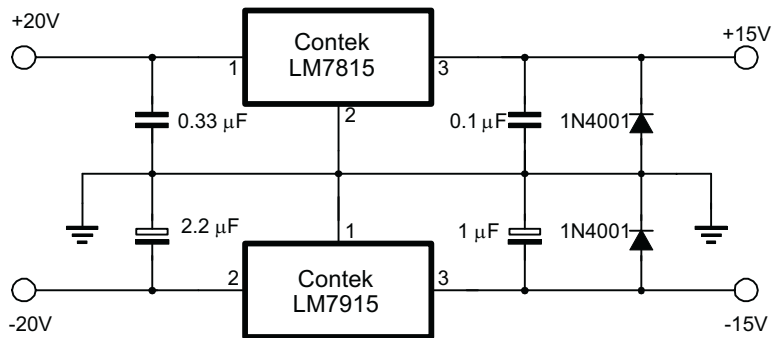

Fig.2 Split power supply(+15V,1A)



Contek Microelectronics Co.,Ltd.

<http://www.contek-ic.com> E-mail:sales@contek-ic.com

# LM79XX LINEAR INTEGRATED CIRCUIT

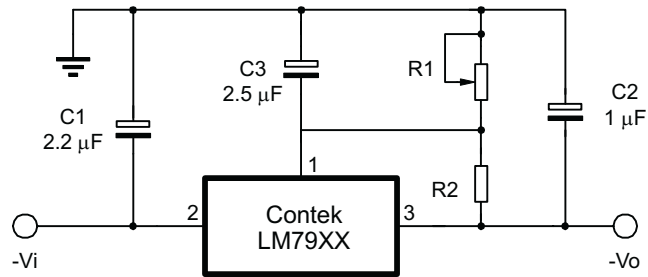

Fig.3 Circuit for increasing output voltage