

Multichannel detector head controller C7557

For control of multichannel detector head and data acquisition



C7557 is specifically designed for basic control in multichannel photometry. When connected to a Hamamatsu multichannel detector head and a personal computer, C7557 allows easy control of the detector head and data acquisition by using dedicated software that comes with the unit. C7557 supports all models of Hamamatsu multichannel detector heads designed to use a CCD image sensor or InGaAs image sensor. C7557 provides various useful functions (see page 2) that efficiently collect sample data during basic operation. C7557 controller includes a driver/amplifier circuit for operating a multichannel detector head, a power supply circuit, a temperature stabilizer circuit, an A/D conversion circuit that converts analog signals from the detector head into digital signals, and a data interface. The software supplied with C7557 allows easy control of the multichannel detector head and data acquisition through the SCSI interface. This software runs on Windows 95/98/Me, by simple operation from the menu neatly displayed on the screen. This software is available with different kinds of DLL*1 to help you develop your own software programs under various developmental environments.

*1: DLL is one of useful functions the Windows 95/98/Me. It is a library that can freely start up from application software or execute function procedure. Software development can be made easier with DLL. To use DLL, see the operation manual that comes with the unit.

Features

- Designed for basic control in multichannel photometry
- Easy to control multichannel detector head and data acquisition
- Supports all models of Hamamatsu multichannel detector heads (CCD, InGaAs)
- Software with different kind of DLL is supplied with C7557
- Compact configuration

Applications

- Control of multichannel detector head and data acquisition

■ Connections to detector head and PC

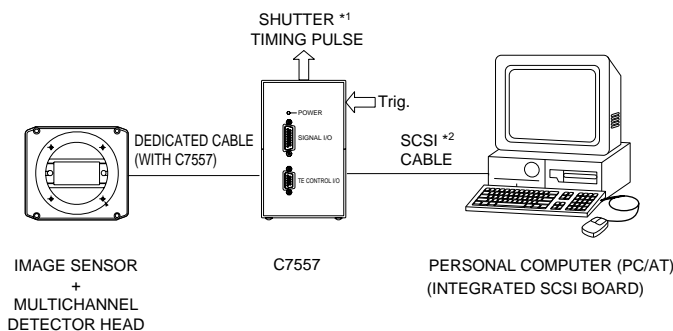

*1: Shutter, etc. are not available.

*2: SCSI cable and SCSI board (card) are not supplied with C7557.

KACCC0077EB

■ Functions

Parameter	Specification
Data transfer	Transfers data stored in memory to computer.
Exposure time setting	1 ms to 65535 ms (1 ms steps) Minimum exposure time depends on sensor detection level.
External sync signal input	BNC connector input
Trigger mode	Internal sync, external sync
Trigger polarity	Trigger polarity selectable for external sync
Shutter timing pulse output	Outputs timing signal for operating external shutter or external light source via BNC connector. Pulse width, delay and polarity settings are possible.
Video signal output	Outputs video signal sent from head, via BNC connector.
Video sync signal output	Outputs sync signal used to observe video signal output with external device such as oscilloscope, via BNC connector.
Amplifier gain	1/2, 1, 2, 5, 10, 20, 50, 100
Detector head	Refer to ■SELECTION GUIDE FOR IMAGE SENSOR AND DETECTOR HEAD COMBINATION
Number of detector channels	
Detector cooling control	
Detector cooling temperature readout	Cooling start and stop Converts analog temperature data from detector into digital signal, and transfers it to computer (10 bit A/D conversion)

■ Specifications
● AD converter

Parameter	CCD area image sensor	InGaAs linear image sensor	
AD converter	16 bits	12 bits	16 bits
Conversion speed	4 μ s/ch	2 μ s/ch	8 μ s/ch
Input range	0 to 10 V	-10 to +10 V	
Input method	Differential input		
Nonlinear linearity	0.1 %FS		
AD conversion signal	External input		

● Controller

Parameter	Specification
Clock	20 MHz
Memory	4 MB (1024 ch \times 2048 lines)
Interface	SCSI

● Equipment

Parameter	Specification
Interface	SCSI: 50-pin half pitch connector
Power supply	AC100 to 240 V \pm 10 %, 50 to 60 Hz
Power consumption	33 W Max.
Outline dimension	92 (W) \times 150 (H) \times 225.8 (D) mm
Operating temperature	0 to 40 $^{\circ}$ C
Storage temperature	-10 to 50 $^{\circ}$ C
Weight	Approx. 2.9 kg

● SCSI interface

SCSI boards manufactured by Adaptec, especially types below, are recommended.

PCI bus: AHA-2940AU, 2940U2W, 2940UW, SCSI CARD 2930U, 19160, PCMCIA: APA-1460A, 1480

● Software

Parameter	Specification
Compatible OS *3	Windows95, Windows98, Windows ME

*3: This software may be run on Windows 2000, NT or XP with a simple task. For information on how to do this, please consult with our sales office.

● Others

BNC cable is separately required when making measurements by external sync, controlling an external shutter or external light source, or measuring the video signal with an external device.

■ Operation method

1. Make connections as indicated in ① to ⑤.

- ① LINE Connect to the power cable.
- ② SCSI *4 Connect to a computer through the SCSI interface cable. When C7557 is the last unit in the SCSI chain, plug a terminator into another SCSI port on C7557.
- ③ TE CONTROL I/O Connect to the "TE CONTROL I/O" terminal on the detector head.
- ④ SIGNAL I/O Connect to the "I/O SIGNAL" terminal on the detector head.
- ⑤ GND When a 2-pin AC plug is used with the power cable, use this GND connector to ground the unit.

2. When all the connections are complete, turn on the power to C7557.

3. Install the dedicated software. (For details on the dedicated software, refer to the operation manual supplied in the package.)

*4: A terminator must be plugged into the last unit in the SCSI chain.

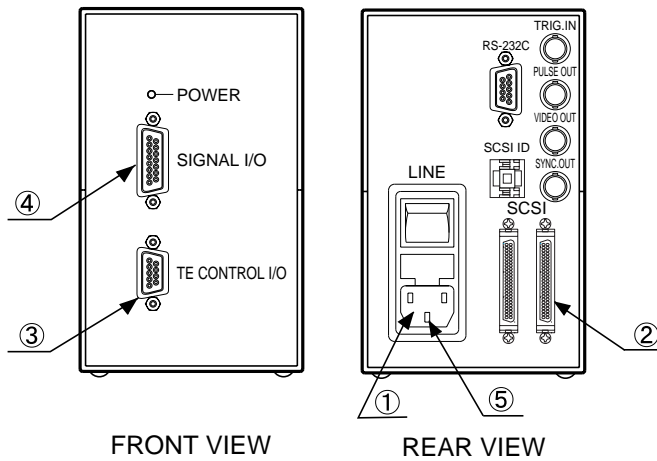

KACCC0083EC

■ Software functions

The figure below shows the main screen (CCD image sensor: line binning) while running on Windows 95/98/Me. From the main screen menu, you can easily set operating conditions for the multichannel detector head and data acquisition parameters. The measurement screen displayed with this software shows the image sensor channel along the horizontal axis and the output count along the vertical axis. The main screen menu also allows you to select the desired operation mode: line binning or area scanning (for CCD image sensors), or line scanning (for InGaAs image sensors).

The parameters that can be set on the main screen are as follows:

- Exposure time
- Amplifier gain
- Cooling control
- Number of integrations
- Dark correction
- Type of measurement data
- Start or end of measurement
- Detector head status
- Trigger mode
- Trigger polarity
- Shutter timing pulse width
- Shutter timing pulse delay
- Shutter timing pulse polarity

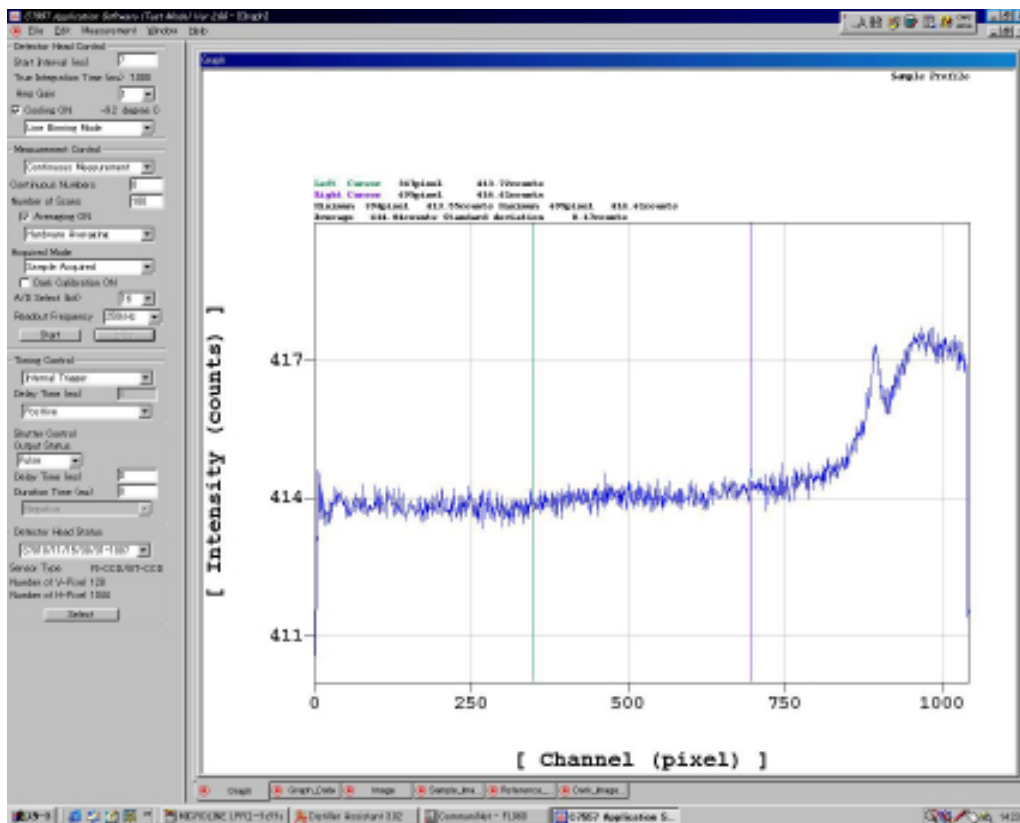

■ Selection guide for image sensor and detector head combination

Suitable multichannel detector head	Image sensor			
Type No.	Type No.	Number of active pixel	Active area [mm (H) × mm (V)]	Types of sensor
C7020	S7010-0906	512 × 60	12.288 × 1.440	Front-illuminated CCD area image sensor
	S7010-0907	512 × 124	12.288 × 2.976	
	S7010-0908	512 × 252	12.288 × 6.048	
	S7010-1006	1024 × 60	24.576 × 1.440	
	S7010-1007	1024 × 124	24.576 × 2.976	
	S7010-1008	1024 × 252	24.576 × 6.048	
C7021	S7011-0906	512 × 60	12.288 × 1.440	
	S7011-0907	512 × 124	12.288 × 2.976	
	S7011-1006	1024 × 60	24.576 × 1.440	
	S7011-1007	1024 × 124	24.576 × 2.976	
C7025	S7015-0908	512 × 252	12.288 × 6.048	
	S7015-1008	1024 × 252	24.576 × 6.048	
C7040	S7030-0906	512 × 58	12.288 × 1.392	Back-thinned ^{*5} CCD area image sensor
	S7030-0907	512 × 122	12.288 × 2.928	
	S7030-0908	512 × 250	12.288 × 6.000	
	S7030-1006	1024 × 58	24.576 × 1.392	
	S7030-1007	1024 × 122	24.576 × 2.928	
	S7030-1008	1024 × 250	24.576 × 6.000	
C7041	S7031-0906	512 × 58	12.288 × 1.392	
	S7031-0907	512 × 122	12.288 × 2.928	
	S7031-0908	512 × 250	12.288 × 6.000	
	S7031-1006	1024 × 58	24.576 × 1.392	
	S7031-1007	1024 × 122	24.576 × 2.928	
	S7031-1008	1024 × 250	24.576 × 6.000	
C7043	S7033-0907	512 × 122	12.288 × 2.928	
	S7033-1007	1024 × 122	24.576 × 2.928	
C7044	S7034-0907	512 × 122	12.288 × 2.928	
	S7034-1007	1024 × 122	24.576 × 2.928	
C7180	S7170-0909	512 × 512	12.288 × 12.288	
C7181	S7171-0909	512 × 512	12.288 × 12.288	
C8060-01	G9201-256R	256	12.8 × 0.25	InGaAs linear image sensor
	G9202-512R	512	12.8 × 0.25	
	G9203-256R	256	12.8 × 0.50	
	G9204-512R	512	12.8 × 0.50	
C8061-01	G9201-256S	256	12.8 × 0.25	
	G9202-512S	512	12.8 × 0.25	
	G9203-256S	256	12.8 × 0.50	
	G9204-512S	512	12.8 × 0.50	
	G9211-256S	256	12.8 × 0.25	
	G9212-512S	512	12.8 × 0.25	
	G9213-256S	256	12.8 × 0.50	
	G9214-512S	512	12.8 × 0.50	
C8062-01	G9205-256W	256	12.8 × 0.25	
	G9206-256W	256	12.8 × 0.25	
	G9207-256W	256	12.8 × 0.25	
	G9208-256W	256	12.8 × 0.25	

*5: C7557 can be used with following back-thinned CCD area image sensors and multichannel detector heads

- Two-stage TE-cooled CCD S7032 series/multichannel detector head C7042
- Two-stage TE-cooled CCD S7035 series/multichannel detector head C7045
- Two-stage TE-cooled CCD S7172-0909/multichannel detector head C7182

■ Dimensional outline (unit: mm)

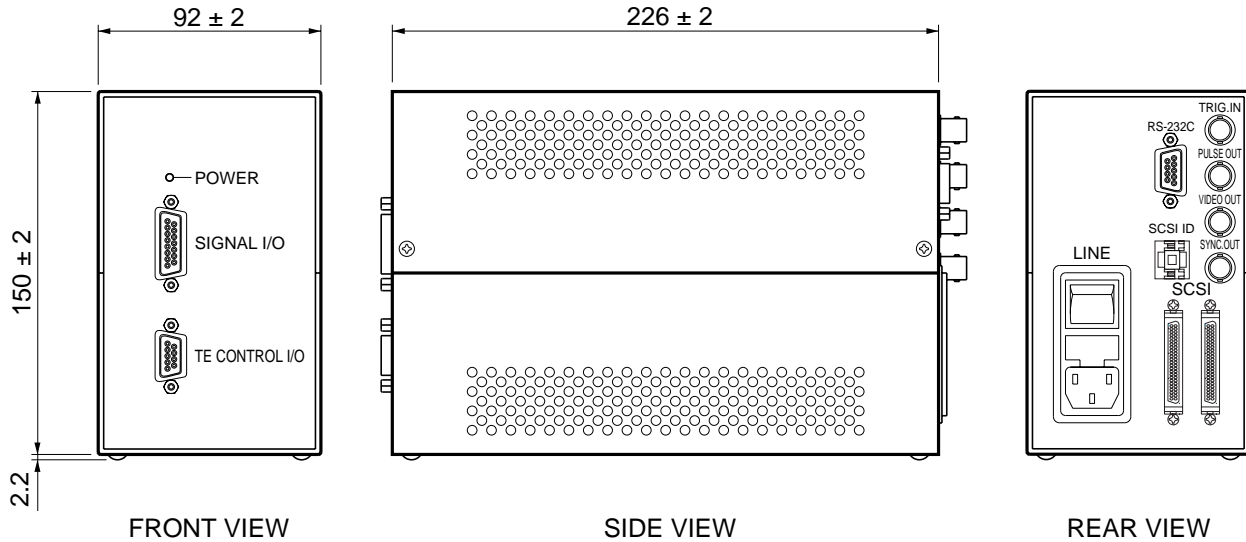

KACCA0061EC

■ Configuration

- C7557 main unit 1
- SCSI terminator 1
- Fuse (1.6 A) 1
- Detector head connection cables 2
- AC cable 1
- Software 1
- Operation manual 1

■ Caution

SCSI cable and SCSI board (card) are not supplied with C7557.