

### FEATURES

- 12-Bit binary and 3-digit BCD models
- 7 Output ranges
- $3\mu\text{s}$   $V_{\text{OUT}}$  settling time  
 $300\text{ns}$   $I_{\text{OUT}}$  settling time
- Guaranteed monotonicity over full temperature range
- Integral nonlinearity  $\pm 1/2\text{LSB}$  (binary) and  $\pm 1/4\text{LSB}$  (BCD), maximum
- Differential nonlinearity  $\pm 3/4\text{LSB}$  (binary) and  $\pm 1/4\text{LSB}$  (BCD), maximum
- High-reliability QL versions available



### GENERAL DESCRIPTION

The DAC-HZ Series are high-performance, monolithic, 12-bit binary and 3-digit BCD, digital-to-analog converters. The DAC-HZ Series are complete and self-contained with a precision internal reference and fast output operational amplifier. Pin programmable output voltage and current ranges are provided for a high degree of application flexibility; the binary versions offer 5 output voltage ranges and two current ranges while the BCD models offer 3 and 1 output ranges, respectively.

The DAC-HZ Series contains a precision embedded Zener reference circuit. This eliminates code-dependent ground currents by routing current from the positive supply to the internal ground node as determined by the R-2R ladder network. The internal feedback resistors for the on-board amplifier track the ladder network resistors, enhancing temperature performance. The excellent tracking of the resistors results in temperature coefficients for differential nonlinearity, zero and gain of  $\pm 2$ ,  $\pm 3$  and  $\pm 20\text{ppm}/^\circ\text{C}$  maximum, respectively.

### INPUT/OUTPUT CONNECTIONS

PIN	FUNCTION	PIN	FUNCTION
1	BIT 1 (MSB)	24	REFERENCE OUT
2	BIT 2	23	GAIN ADJUST
3	BIT 3	22	+15V SUPPLY
4	BIT 4	21	GROUND
5	BIT 5	20	CURRENT OUTPUT
6	BIT 6	19	20V RANGE
7	BIT 7	18	10V RANGE
8	BIT 8	17	BIPOLAR OFFSET
9	BIT 9	16	REFERENCE IN
10	BIT 10	15	VOLTAGE OUTPUT
11	BIT 11	14	-15V SUPPLY
12	BIT 12 (LSB)	13	NO CONNECTION

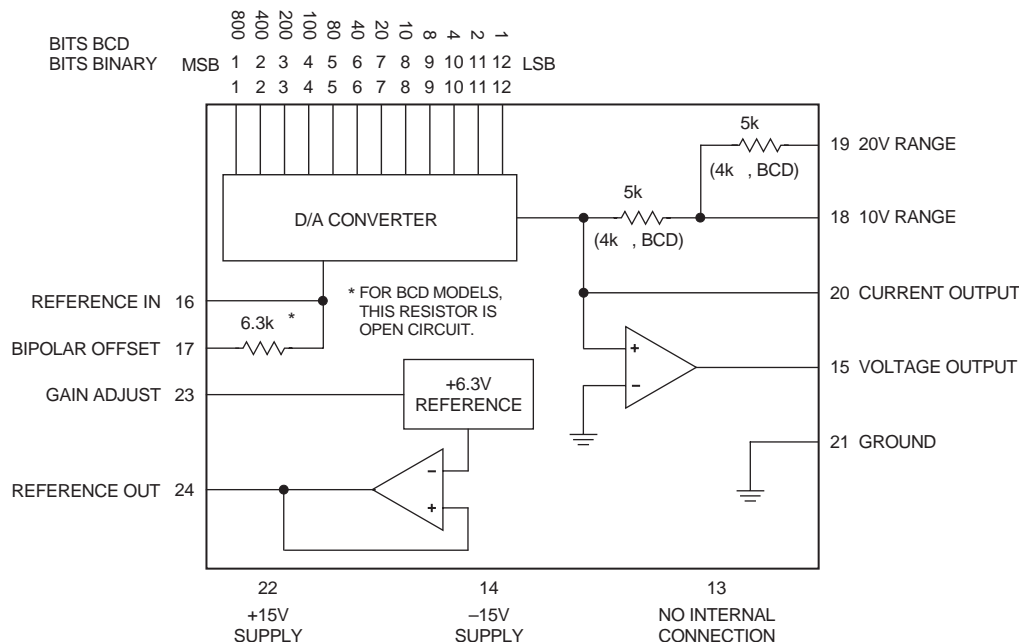

Figure 1. Functional Block Diagram

**ABSOLUTE MAXIMUM RATINGS**

Positive Supply, Pin 22	+18V
Negative Supply, Pin 14	-18V
Digital Input Voltage, Pins 1-12	+5.5V
Output Current, Pin 15	±20mA
Lead Temperature (soldering, 10s)	300°C

**FUNCTIONAL SPECIFICATIONS**

(Typical at +25°C and ±15V supplies unless otherwise noted.)

INPUTS	DAC-HZ12B (BINARY)	DAC-HZ12D (BCD)
<b>Resolution</b>	12 binary bits	3 BCD digits
<b>Coding, Unipolar Output</b>	Comp. binary	Comp. BCD
<b>Coding, Bipolar Output</b>	Comp. off. binary	—
<b>Input Logic Level, Bit ON ("0")</b>	0V to +0.8V at -1mA	
<b>Input Logic Level, Bit OFF ("1")</b>	+2.4V to +5.5V at +40µA	
<b>Logic Loading</b>	1 TTL load	
<b>PERFORMANCE ①</b>		
<b>Voltage Output Nonlinearity</b>	±1/2LSB max.	±1/4LSB max.
<b>Differential Nonlinearity</b>	±3/4LSB max	±1/4LSB max.
<b>Gain Error, Before Trimming</b>	±0.1% ②	*
<b>Zero Error, Before Trimming</b>	±0.1% of FSR ②	*
<b>Gain Tempco, maximum</b>	±20ppm/°C	*
<b>Zero Tempco, Unipolar, max.</b>	±3ppm/°C of FSR	*
<b>Offset Tempco, Bipolar, max.</b>	±10ppm/°C of FSR	*
<b>Diff. Nonlinearity Tempco, max.</b>	±2ppm/°C of FSR	*
<b>Monotonicity</b>	Over oper. temp. range	*
<b>Settling Time, I<sub>OUT</sub> to ±1/2LSB ③</b>	300ns	*
<b>Settling Time, V<sub>OUT</sub> to ±1/2LSB</b>	3µs ④	*
<b>Slew Rate</b>	±10V/µs	*
<b>Power Supply Rejection</b>	±0.006%FSR/%Sup.	*
<b>OUTPUTS</b>		
<b>Output Current, Unipolar</b>	0 to -2mA, ±20%	0 to -1.25mA, ±10%
<b>Output Current, Bipolar</b>	±1mA, ±20%	—
<b>Compliance Voltage, I<sub>OUT</sub></b>	±2.5V	*
<b>Output Impedance, I<sub>OUT</sub>, Unipolar</b>	2kΩ	*
<b>Output Impedance, I<sub>OUT</sub>, Bipolar</b>	2kΩ	—
<b>Output Voltage Ranges, Unipolar</b>	0 to +5V 0 to +10V	0 to +2.5V 0 to +5V 0 to +10V
<b>Output Voltage Ranges, Bipolar</b>	±2.5V ±5V ±10V	— — —
<b>Output Current, V<sub>OUT</sub></b>	±5mA min.	*
<b>Output Impedance, V<sub>OUT</sub></b>	0.05Ω	*
<b>POWER REQUIREMENTS</b>		
<b>Power Supply Voltages</b>	+15V, ±0.5V at 16mA -15V, ±0.5V at 20mA ±12V operation ⑤	
<b>Power Dissipation, maximum</b>	500mW	
<b>PHYSICAL ENVIRONMENTAL</b>		
<b>Operating Temp. Ranges, Case</b>	0°C to +70° and -55°C to +125°C	
<b>Storage Temp. Range</b>	-65°C to +150°C	
<b>Thermal Impedance</b>		
θ <sub>jc</sub>	7.4°C/W	
θ <sub>ca</sub>	36.6°C/W	
<b>Package Type</b>	24-pin DDIP	
<b>Weight</b>	0.22 ounces (6.3 grams)	

**Footnotes**

- ① FSR is full-scale range and is 10V for 0 to +10V or -5V to +5V outputs, 20V for ±10V output, etc.
- ② Initial gain and offset errors are trimmable to zero. See Connection Diagrams.
- ③ Current output mode.
- ④ For 2.5kΩ or 5kΩ feedback. For 10kΩ feedback, the settling time is 4µs.
- ⑤ For ±12V operation of binary models, contact factory.

**TECHNICAL NOTES**

- The DAC-HZ12 Series converters are designed and factory calibrated to give ±1/2LSB linearity (binary version) and ±1/4LSB linearity (BCD version) with respect to a straight line between end points. This means that if zero and full scale are exactly adjusted externally, the relative accuracy will be ±1/2LSB (±1/4LSB, BCD version) everywhere over the full output range without any additional adjustments.
- These converters must be operated with local supply bypass capacitors from +15V to ground and -15V to ground. Tantalum type capacitors of 1µF are recommended and should be mounted as close as possible to the converter. If the converters are used in a high-frequency noise environment, a 0.01µF ceramic capacitor should be used across each tantalum capacitor.
- When operating in the current output mode, the equivalent internal current source of 2mA (1.25mA, BCD) must drive both the internal source resistances and the external load resistor. A 300ns output settling time is achieved for the voltage across a 100Ω load resistor; for higher value resistors the settling time becomes longer due to the output capacitance of the converter. For fastest possible voltage output for a large transition, an external fast-settling amplifier such as DATEL's AM-500 should be used in the inverting mode. Settling time of less than 1µs can be achieved. See application diagram.

**CALIBRATION PROCEDURE**

- Select the desired output range and connect the converter as shown in the Output Range Selection tables and the connection diagrams.
- To calibrate, refer to the coding tables. Note that complementary coding is used.
- Zero and Offset Adjustments**  
For unipolar operation set all digital inputs to "1" (+2.0 to +5.5V) and adjust the ZERO ADJUST potentiometer for zero output voltage or current. For bipolar operation set all digital inputs to "1" and adjust the OFFSET ADJUST potentiometer for the negative full scale (for voltage out) or positive full scale (for current out) output value shown in the coding table.
- Gain Adjustment**  
Set all digital inputs to "0" (0V to +0.8V) and adjust the GAIN ADJUST potentiometer for the positive full scale (for voltage out) or negative full scale (for current out) output value shown in the coding table.

\* Specifications same as first column.  
— No equivalent specifications

**OUTPUT RANGE SELECTION TABLES**

DAC-HZ12B Binary Output Range Selection				
V <sub>OUT</sub> RANGE	CONNECT THESE PINS TOGETHER			
±10V	15 & 19	17 & 20	—	16 & 24
±5V	15 & 18	17 & 20	—	16 & 24
±2.5V	15 & 18	17 & 20	19 & 20	16 & 24
+10V	15 & 18	17 & 21	—	16 & 24
+5V	15 & 18	17 & 21	19 & 20	16 & 24
±1mA	—	17 & 20	—	16 & 24

DAC-HZ12D BCD Output Range Selection				
+10V	15 & 19	17 & 21	—	16 & 24
+5V	15 & 18	17 & 21	—	16 & 24
+2.5V	15 & 18	17 & 21	19 & 20	16 & 24
-1.25mA	—	17 & 21	—	16 & 24

Voltage output is at pin 15; current output is at pin 20.

**OUTPUT CODING TABLES**

Unipolar Output, Complementary Binary						
BINARY INPUT CODE		UNIPOLAR OUTPUT RANGES				
MSB	LSB	0 to +10V	0 to +5V	0 to +2.5V	0 to -2mA	
0000	0000	+9.9976V	+4.9988V			-1.9995
0011	1111	+7.5000	+3.7500			-1.5000
0111	1111	+5.0000	+2.5000			-1.0000
1011	1111	+2.5000	+1.2500			-0.5000
1111	1111	+0.0024	+0.0012			-0.0005
1111	1111	0.0000	0.0000			0.0000

Unipolar Output, Complementary BCD						
BCD INPUT CODE		UNIPOLAR OUTPUT RANGES				
MSB	LSB	0 to +10V	0 to +5V	0 to +2.5V	0 to -2mA	
0110	0110	+9.990	+4.995	+2.498		-1.2488
1000	1010	+7.500	+3.750	+1.875		-0.9375
1010	1111	+5.000	+2.5000	+1.250		-0.6250
1101	1010	+2.5000	+1.250	+0.625		-0.3125
1111	1111	+0.0100	+0.005	+0.003		-0.0013
1111	1111	0.0000	0.0000	0.0000		0.0000

Bipolar Output, Complementary Offset Binary						
INPUT CODE		BIPOLAR OUTPUT RANGES				
MSB	LSB	±10V	±5V	±2.5V	±1mA	
0000	0000	+9.9951	+4.9976	+2.4988		-0.9995
0011	1111	+5.0000	+2.5000	+1.2500		-0.5000
0111	1111	0.0000	0.0000	0.0000		0.0000
1011	1111	-5.0000	-2.5000	-1.2500		+0.5000
1111	1111	-9.9951	-4.9976	-2.4988		+0.9995
1111	1111	-10.0000	-5.0000	-2.5000		+1.0000

**CONNECTION DIAGRAMS**

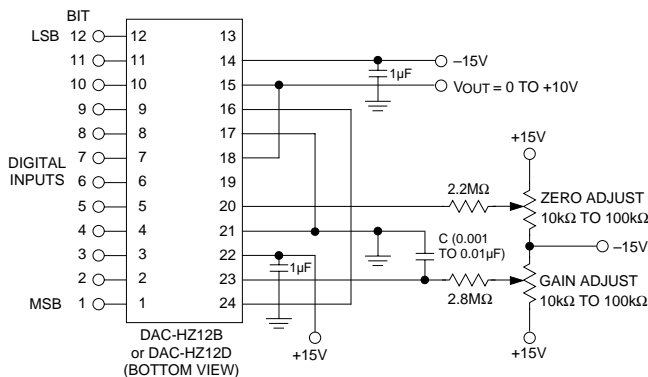

Figure 2. Unipolar Voltage Output Connections

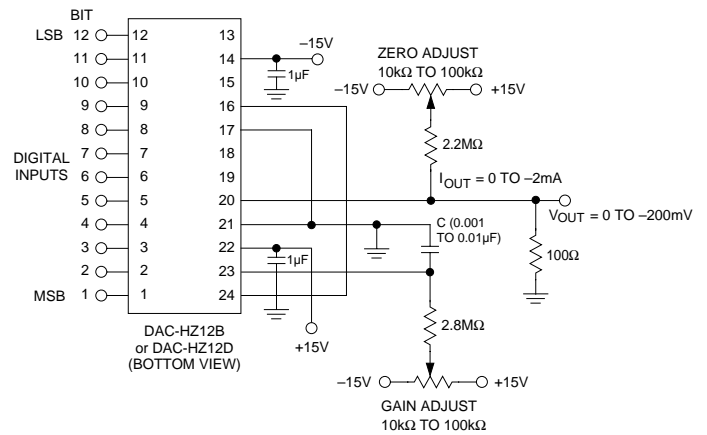
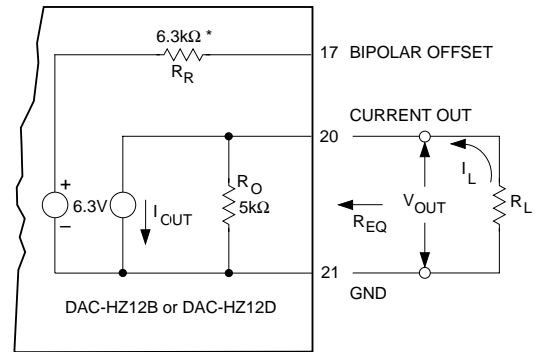

Figure 3. Unipolar Current Output Connections



\*This resistor is open circuit for BCD models

$V_{OUT} = \pm 2.5V$  Maximum  
(Output compliance voltage)

$R_{EQ} = R_O = 5k\Omega$  for unipolar operation

$R_{EQ} = R_R \parallel R_O = 2.8k\Omega$  for bipolar operation

$I_{OUT} = 2mA$  binary  
 $= 1.25mA$  BCD

Figure 4. Equivalent Current Mode Output Circuit

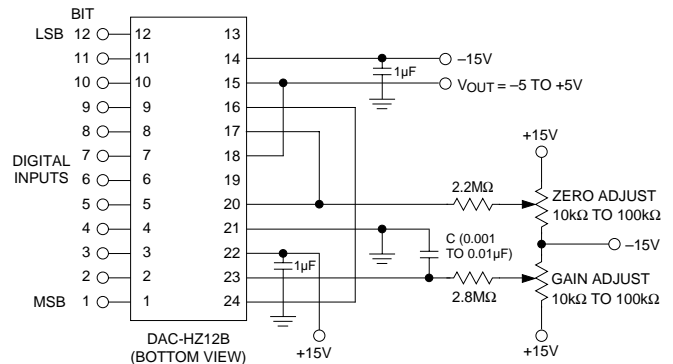

Figure 5. Bipolar Voltage Output Connections

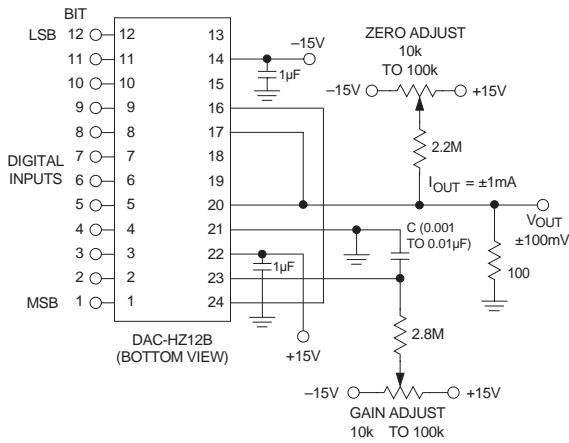
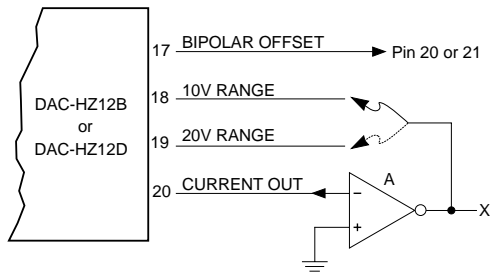

Figure 6. Bipolar Current Output Connections



A = External high-speed inverting op amp; use DATEL's AM-500 for less than 1µsec output settling.

Refer to the output range selection tables, Tables 1 and 2. Wherever pin 15 appears, use pin X of the external amplifier and scale as desired.

Figure 7. Using a High-Speed External Op Amp for Faster Settling

MECHANICAL DIMENSIONS INCHES (mm)

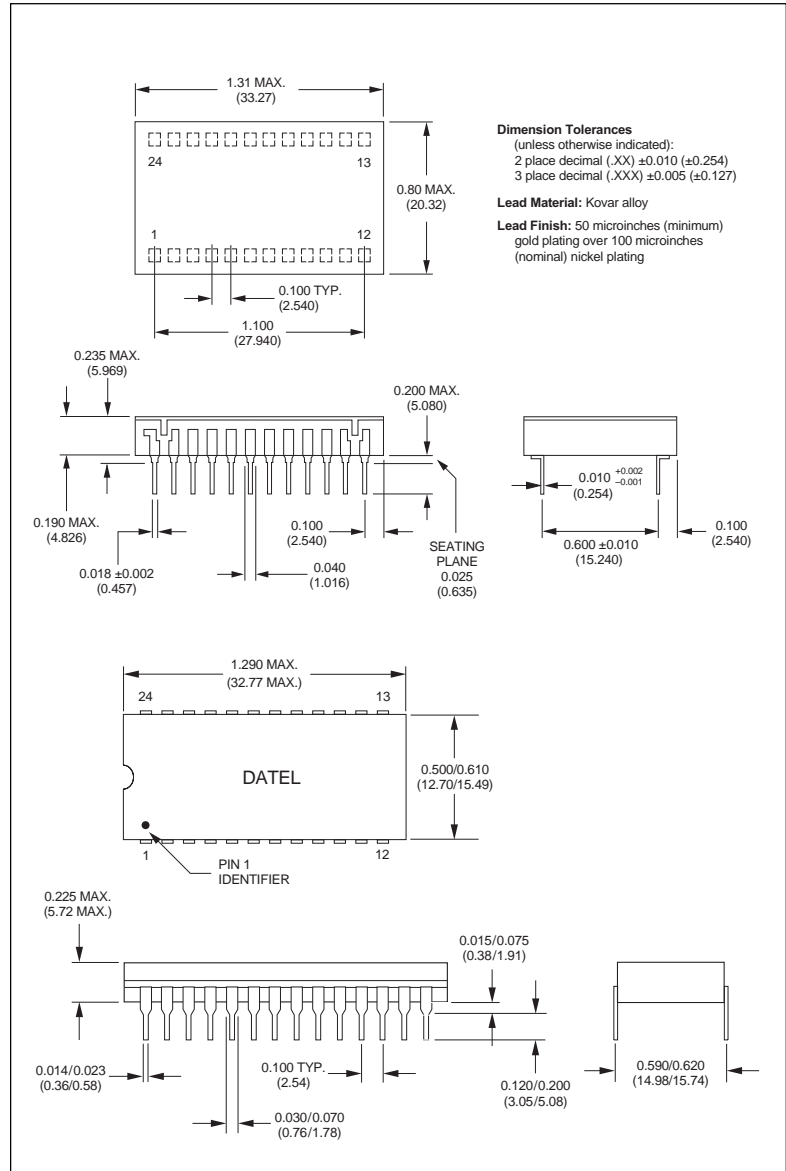

ORDERING INFORMATION

MODEL	OPERATING TEMP. RANGE	OUTPUT CODING	MODEL	OPERATING TEMP. RANGE	OUTPUT CODING
DAC-HZ12BGC	0 to +70°C	Binary	DAC-HZ12DGC	0 to +70°C	BCD
DAC-HZ12BMC	0 to +70°C	Binary	DAC-HZ12DMC	0 to +70°C	BCD
DAC-HZ12BMM	-55 to +125°C	Binary	DAC-HZ12DMM	-55 to +125°C	BCD
DAC-HZ12BMM-QL	-55 to +125°C	Binary	DAC-HZ12DMM-QL	-55 to +125°C	BCD

Contact DATEL for information concerning our QL high-reliability screening program.