

2.7-W MONO FILTER-FREE CLASS-D AUDIO POWER AMPLIFIER

GENERAL DESCRIPTION

The TMPA2055DM is a mono class-D filter-free audio power amplifier IC. It delivers up to 2.7W power into a 3 ohms load or 2.3W power into a 4 ohm load or 1.5W power into an 8 ohm load. Two patents are pending.

With common mode input structure, TMPA2055DM requires no input or output coupling capacitors. It also features high Common Mode Rejection Ratio and Power Supply Rejection Ratio.

For multiple-input applications, independent gain control and corner frequency can be implemented by summing the input sources through resistor ratio and input capacitor values.

Analog input signal is converted into digital output which drives directly to the speaker. High power efficiency is achieved due to digital output at the load. The audio information is embedded in PWM (Pulse Width Modulation) .

APPLICATIONS

Multimedia application includes Cellular Phones, PDAs, DVD/CD players, TFT LCD TVs/Monitors, 2.1 channel/5.1 channel audio systems, USB audio. It is also ideal for other portable devices like Wireless Radios.

REFERENCE CIRCUIT

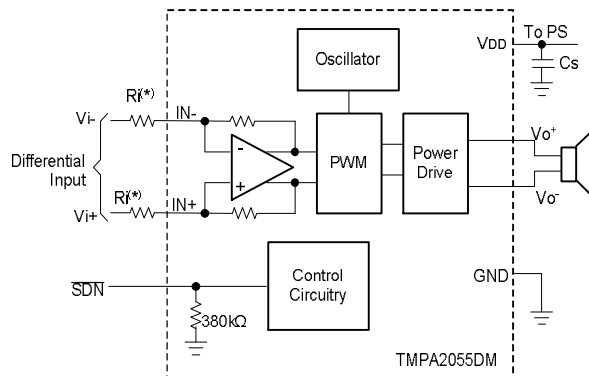

(*)Ris are optional.

FEATURES

- ◆ 4.5V to 5.5V Single Supply
- ◆ Up to 2.7W at 5V, 3 ohms
- ◆ Up to 85% Power Efficiency
- ◆ 2.2mA Quiescent Current at 5V
- ◆ Less Than 0.2uA Shutdown Current
- ◆ Popless Power-Up, Shutdown and Recovery
- ◆ Differential 230 KHz PWM Allows Bridge-Tied Load to Doubles Output Power and Eliminates LC Output Filter
- ◆ Common Mode Structure Requires No Input Capacitors
- ◆ BTL Output Requires No Output Capacitors
- ◆ Thermal Shutoff and Automatic Recovery
- ◆ Short-Circuit Protection
- ◆ Differential Signal Processing Improves CMRR
- ◆ Package : TSSOP8, SOP8, MSOP8 Available

For best performance, please refer to

<http://www.taimec.com.tw/data/Tmpa2055EVM/tmpa2055dmEVM.pdf>

for PCB layout.

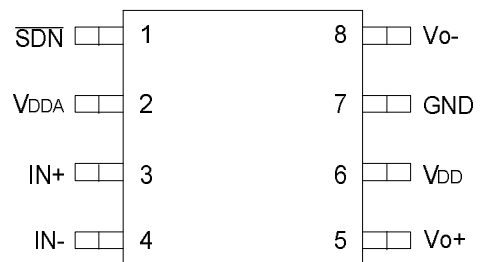

(Please email david@taimec.com.tw for complete datasheet.)

Tai-1 Microelectronics reserves the right to make corrections, modifications, enhancements, improvements, and other changes to its products and services at any time and to discontinue any product or service without notice. Customers are responsible for their products and applications using Tai-1 Microelectronics components.

Note that the external components or PCB layout should be designed not to generate abnormal voltages to the chip to prevent from latch up which may cause damage to the device.

ABSOLUTE MAXIMUM RATINGS

Over operating free-air temperature range unless otherwise noted(1)

| | | | |
|---|---------------------------------|--------------------------------|----|
| Supply voltage, V _{DD} | In normal mode | -0.3V to 6V | V |
| | In shutdown mode | -0.3V to 7V | V |
| Input voltage, V _I | | -0.3V to V _{DD} +0.3V | V |
| Continuous total power dissipation | See package dissipation ratings | | |
| Operating free-air temperature, T _A | | -20 to 85 | °C |
| Operating junction temperature, T _J | | -20 to 150 | °C |
| Storage temperature, T _{stg} | | -40 to 150 | °C |
| Lead temperature 1,6mm(1/16 inch)from case for 10 seconds | | 260 | °C |

(1) Stresses beyond those listed under "absolute maximum ratings" may cause permanent damage to the device. These are stress ratings only, and functional operation of the device at these or any other conditions beyond those indicated under "recommended operating conditions" is not implied. Exposure to absolute-maximum-rated conditions for extended periods may affect device reliability.

RECOMMENDED OPERATING CONDITONS

| | | MIN | NOM | MAX | UNIT |
|--|--|-----|-----|-----------------|------|
| Supply voltage, V _{DD} | | 4.5 | | 5.5 | V |
| High-level input voltage, V _{IH} | SDN | 2 | | V _{DD} | V |
| Low-level input voltage, V _{IL} | SDN | 0 | | 0.8 | V |
| Input resistor, R _i | Gain ≤ 20 V/V (26dB) | 0 | | | kΩ |
| Common Mode Input Voltage Range | V _{DD} =V _{DDA} =4.5V~5.5V, CMRR ≤ -55dB | 0 | | V _{DD} | V |
| Operating free-air temperature, T _A | | -20 | | 85 | °C |

PACKAGE DISSIPATION RATINGS

| PACKAGE | DERATING FACTOR | T _A ≤ 25 °C POWER RATING | T _A = 70 °C POWER RATING | T _A = 85 °C POWER RATING |
|---------|-----------------|--|--|--|
| SOP8 | 6.39mW/ °C | 0.799W | 0.511W | 0.415W |

ELECTRICAL CHARACTERISTICS

T_A=25 °C (unless otherwise noted)

| PARAMETER | TEST CONDITIONS | MIN | TYP | MAX | UNIT |
|---------------------|---|-------------------------------|-------------------------------|-------------------------------|------|
| V _{OS} | Output offset voltage (measured differentially) V _I =0V, A _V =2, V _{DD} =V _{DDA} =4.5V to 5.5V | | 25 | | mV |
| PSRR | Power supply rejection ratio V _{DD} =V _{DDA} =4.5V to 5.5V | | -75 | -55 | dB |
| CMRR | Common mode rejection ratio V _{DD} =V _{DDA} =4.5V to 5.5V, V _{IC} =1V _{pp} , R _L =8Ω | | -55 | -50 | dB |
| I _{IH} | High-level input current V _{DD} =V _{DDA} =5.5V, V _I =5.8V (SDN) | | | 20 | μA |
| I _{IL} | Low-level input current V _{DD} =V _{DDA} =5.5V, V _I =-0.3V (SDN) | | | 1 | μA |
| I _Q | Quiescent current V _{DD} =V _{DDA} =5V, no load | | 2 | 3 | mA |
| I _Q (SD) | Shutdown current V _I (SDN)=0.8V, V _{DD} =V _{DDA} =4.5V to 5.5V | | 0.2 | 0.5 | μA |
| r _{DS(on)} | Static drain-source on-state resistance V _{DD} =V _{DDA} =4.5V | | 790 | | mΩ |
| f _(sw) | Switching frequency V _{DD} =V _{DDA} =4.5V to 5.5V | 200 | 230 | 260 | kHz |
| A _v | BTL Gain V _{DD} =V _{DDA} =4.5V to 5.5V | 135kΩ R _I +15kΩ | 150kΩ R _I +15kΩ | 165kΩ R _I +15kΩ | V/V |
| | Resistance from shutdown to GND | | 380 | | kΩ |

OPERATING CHARACTERISTICS

T_A=25 °C, A_v=2, R_L=8Ω speaker (unless otherwise noted)

| PARAMETER | TEST CONDITIONS | MIN | TYP | MAX | UNIT |
|----------------|--|------|------|------|------|
| P _o | Output power THD+N=10%, f=1kHz, R _L =8Ω V _{DD} =V _{DDA} =5V | | 1.5 | | W |
| P _o | Output power THD+N=10%, f=1kHz, R _L =4Ω V _{DD} =V _{DDA} =5V | | 2.3 | | W |
| P _o | Output power THD+N=10%, f=1kHz, R _L =3Ω V _{DD} =V _{DDA} =5V | | 2.7 | | W |
| THD+N | Total harmonic distortion plus noise V _{DD} =V _{DDA} =5V, P _O =0.85W, R _L =8Ω, f=1kHz | | 0.55 | | % |
| | V _{DD} =V _{DDA} =5V, P _O =1.3W, R _L =4Ω, f=1kHz | | 0.55 | | |
| | V _{DD} =V _{DDA} =5V, P _O =1.5W, R _L =3Ω, f=1kHz | | 0.64 | | |
| SNR | Signal-to-noise ratio V _{DD} =V _{DDA} =5V, P _O =1W, R _L =8Ω | | 84 | | dB |
| Z _i | Input impedance | 13.5 | 15 | 16.5 | kΩ |

TOP VIEW

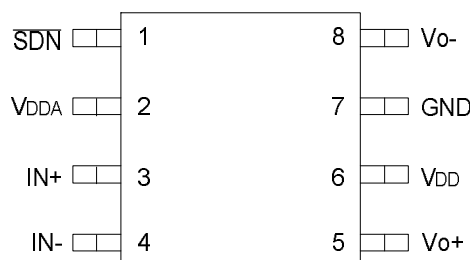

TERMINAL FUNCTIONS

| TERMINAL | | I/O | DESCRIPTION |
|------------------|--------|-----|--------------------------------------|
| NAME | PIN NO | | |
| IN- | 4 | I | Negative differential input |
| IN+ | 3 | I | Positive differential input |
| V _{DD} | 6 | I | Digital Power supply |
| VO+ | 5 | O | Positive BTL output |
| GND | 7 | I | Digital ground |
| V _{O-} | 8 | O | Negative BTL output |
| SDN | 1 | I | Shutdown terminal (active low logic) |
| V _{DDA} | 2 | I | Analog Power supply |

TYPICAL CHARACTERISTICS

Note 1. Input coupling 1 μ F capacitors are used for all measurements.

2. Differential inputs are applied and BTL outputs are measured.
3. Balanced LC filter is used for THD+N measurement and power efficiency measurement.
4. Characteristic frequency of the LC filter is set 41KHz unless otherwise specified.

APPLICATION INFORMATION

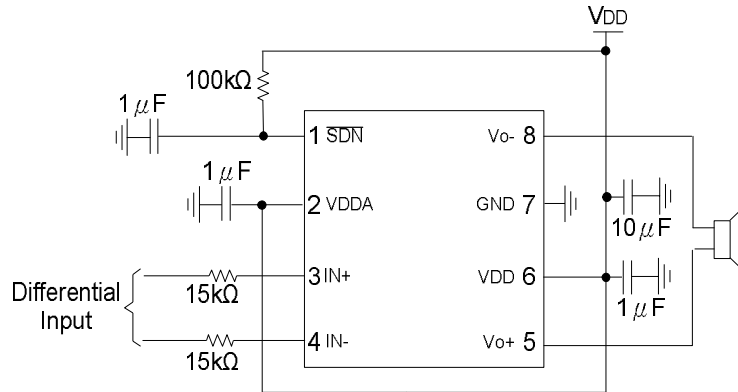

Suppose source impedance of the input is relatively smaller than 15k ohms.

Figure.1 Differential Input With Gain= $\frac{150k}{15k+15k} = 5$

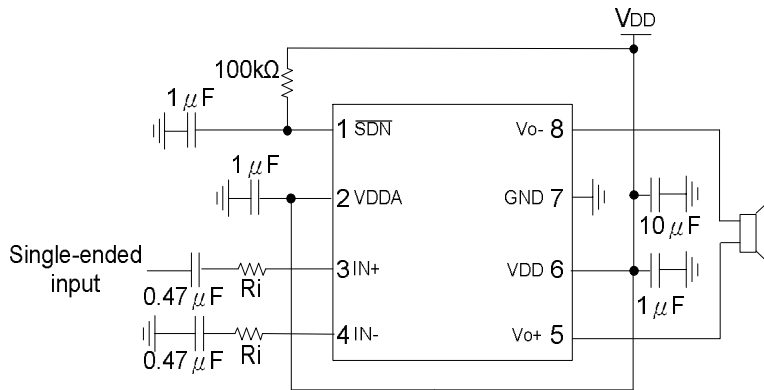

Ri=15k ohms if source impedance of the input is relatively smaller than 15k ohms.

Figure.2 Single-ended Input With Gain= $\frac{150k}{15k+Ri}$

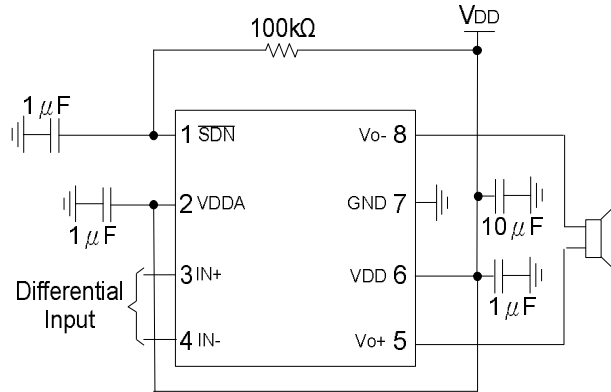

Suppose source impedance of the input is much smaller than 15k.

Figure.3 Differential Input With Gain = $\frac{150k}{15k} = 10$

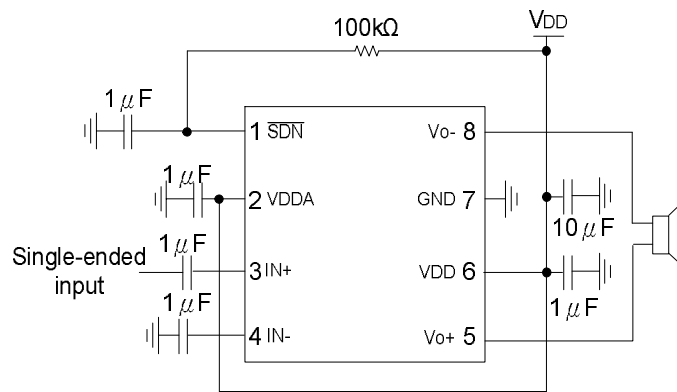

Suppose source impedance of the input is much smaller than 15k.

Figure.4 Single-ended Input With Gain = $\frac{150k}{15k} = 10$

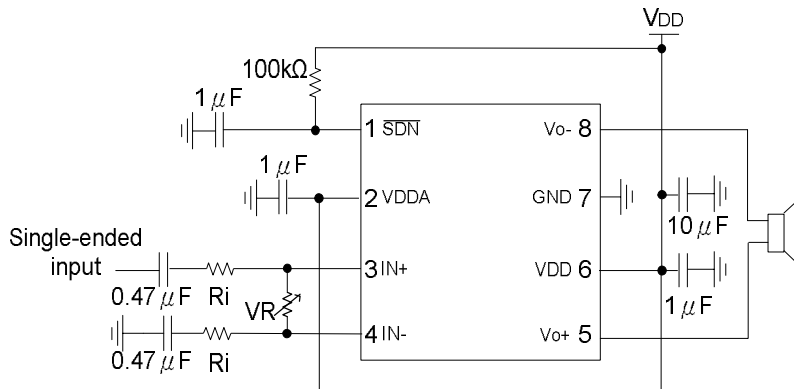

Figure.5 Single-ended Input With Gain Control

Note : Please refer to document 010 APP for more application examples.

Figure 5 ~7 show typical ferrite bead and LC output filters.

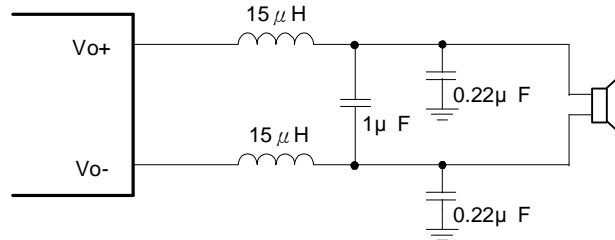

Figure 5. Typical LC Output Filter, Cutoff Frequency of 41 kHz, Speaker Impedance=4Ω

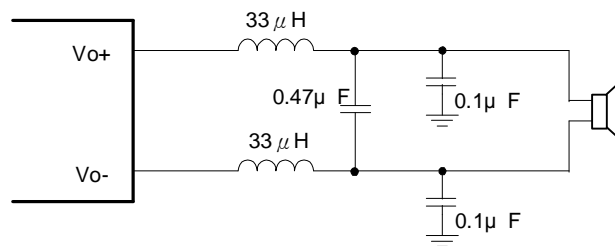

Figure 6. Typical LC Output Filter, Cutoff Frequency of 41 kHz, Speaker Impedance=8Ω

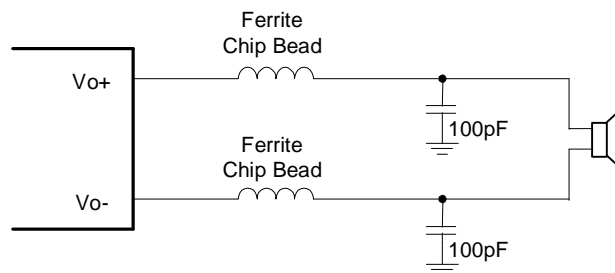

Figure 7. Typical Ferrite Chip Bead Filter
(Chip bead example : 遠越科技 KML2012Q102N
1kohms@100MHz, DCR=0.2ohms, I=1A)

I Input Resistors and Gain

The BTL gain of the amplifier is determined by

$$\text{Gain} = \frac{150\text{kohms}}{R_i + 15\text{kohms}}$$

where R_i is the source impedance of the input signal.

Physical Dimensions (IN MILLIMETERS)

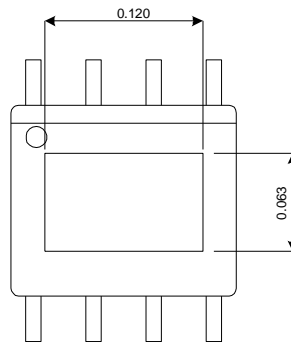
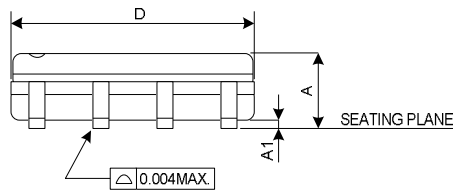
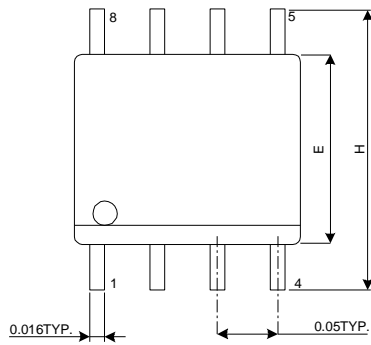

| SYMBOLS | MIN. | MAX. |
|---------|-------|-------|
| A | 0.053 | 0.069 |
| A1 | 0.004 | 0.010 |
| D | 0.189 | 0.196 |
| E | 0.150 | 0.157 |
| H | 0.228 | 0.244 |

SOP8

Physical Dimensions (IN MILLIMETERS)

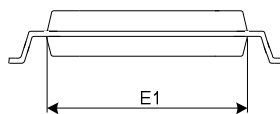
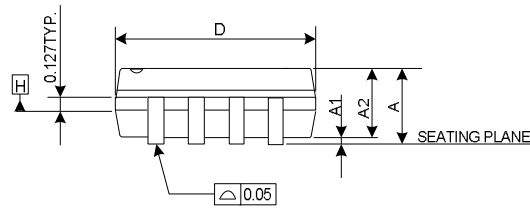
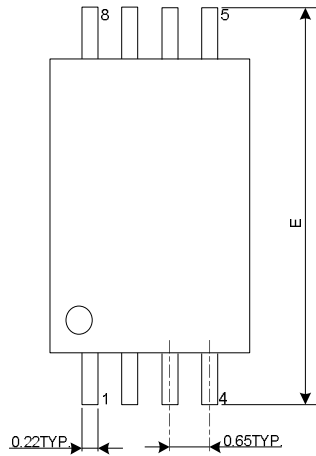

| SYMBOLS | MIN. | NDM. | MAX. |
|---------|----------|------|------|
| A | - | - | 1.20 |
| A1 | 0.05 | - | 0.15 |
| A2 | 0.96 | 1.01 | 1.06 |
| D | 2.90 | 3.00 | 3.10 |
| E | 6.40 BSC | | |
| E1 | 4.30 | 4.40 | 4.50 |

TSSOP8

IMPORTANT NOTICE

Tai-1 Microelectronics Corp. reserves the right to make changes to its products and services and to discontinue any product or service without notice. Customers should obtain the latest relevant information for reference. Testing and quality control techniques are used to screen the parameters. Testing of all parameters of each product is not necessarily performed.

Tai-1 Microelectronics Corp. assumes no liability for applications assistance or customer product design. To minimize the risks associated with customer products and applications, customers should provide adequate design and operating safeguards.

Reproduction of information in data sheets or related documentation is permissible only if reproduction is without alteration and is accompanied by all associated warranties, conditions, limitations, and notices. Tai-1 Microelectronics Corp. is not responsible or liable for such altered documentation.

Resale of Tai-1 Microelectronics Corp. products or services with statements different from the parameters stated by Tai-1 Microelectronics Corp. for that product or service voids all express and any implied warranties. Tai-1 Microelectronics Corp. is not responsible or liable for any such statements.

Copyright ©2004, Tai-1 Microelectronics Corp.