

# Agilent HFBR-1506AM/HFBR-2506AM Fiber Optic SMA Transmitters and Receivers for 16 MBd SERCOS Applications Data Sheet

## Description

SERCOS, an acronym for **S**ERial **R**ealtime **C**OMmunications **S**ystems, is a standard digital interface for communication in industrial CNC applications. SERCOS is a European (EN 61491) and international standard (IEC 61491). The optical interface allows data rates of 2,4,8 and 16 MBd and data transfer between numerical controls and drives via fiber-optic rings, with voltage isolation and noise immunity. The HFBR-1506AM and HFBR-2506AM products have a guaranteed performance up to 16 MBd.

## Package Information

The transmitters and receivers are housed in a low-cost, dual-in-line package that is made of high strength, heat resistant, chemically resistant and UL 94V-O (UL file # E121562) flame retardant plastic. Both the transmitter and receiver are coated with a layer of conductive alloy for better air discharge (ESD) performance. The package is designed for auto insertion and wave soldering so it is ideal for high volume production applications.



## Handling and Design Information

When soldering, it is advisable to leave the protective cap on the unit to keep the optics clean. Good system performance requires clean port optics and cable ferrules to avoid obstructing the optical path. Clean compressed air often is sufficient to remove particles of dirt; methanol on a cotton swab also works well.

## Recommended Chemicals for Cleaning/Degreasing

*Alcohols:* methyl, isopropyl, isobutyl.

*Aliphatics:* hexane, heptane.

*Other:* soap solution, naphtha.

**Do not use** partially halogenated hydrocarbons such as 1,1,1 trichloroethane, ketones such as MEK, acetone, chloroform, ethyl acetate, methylene dichloride, phenol, methylene chloride or N-methylpyrrolidone. Also, Agilent does not recommend the use of cleaners that use halogenated hydrocarbons because of their potential environmental harm.

## Features

- Meets Industrial SERCOS 16MBd standard
- SMA ports
- 650 nm wavelength
- Metal coated, plastic packaging
- Specified for use with 1 mm POF and 200  $\mu$ m HCS
- DC - 16 MBd data rate

## Applications

- Industrial Control Data Links
- Factory Automation Data Links
- Voltage Isolation Applications



**CAUTION:** The small junction size inherent in the design of these components increases the components' susceptibility to damage from electrostatic discharge (ESD). It is advised that normal static precautions be taken in handling and assembly of these components to prevent damage and/or degradation which may be induced by ESD.

**Table 1. Link Performance Specification**

0 °C to +70 °C unless otherwise noted.

Parameter	Symbol	Min	Max	Unit	Condition	Reference
Link distance with	l	0.1	45	m	POF	Note 1, 2, 4, 6
HFBR-1506AM/2506AM		0.1	200	m	HCS	Note 1, 3, 5, 6

**Notes:**

1. 60 mA nominal drive current.
2. POF HFBR-Exxyyy 0.23 dB/m worst case attenuation.
3. HCS 10 dB/km worst case attenuation.
4. Including a 3 dB optical safety margin accounting for link service lifetime.
5. Including a 2 dB optical safety margin accounting for link service lifetime.
6. Signaling rate dc to 16 MBd.

### HFBR-1506AM Transmitter

The HFBR-1506AM transmitter incorporates a 650nm LED in a metal-coated, plastic housing. The high light output power enables the use of both plastic optical fiber (POF) and Hard Clad Silica (HCS). This transmitter can operate up to 16MBd using a simple driver circuit. The HFBR-1506AM is compatible with SMA connectors.

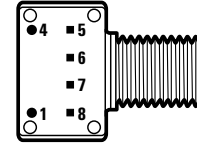

BOTTOM VIEW,  
HFBR-1506AM

SEE NOTE 4

PIN	FUNCTION
1	CONNECTED TO PIN 4
4	CONNECTED TO PIN 1
5	GND
6	GND
7	CATHODE
8	ANODE

### Absolute Maximum Ratings

Figure 1.

Parameter	Symbol	Min	Max	Unit	Notes
Storage and Operating Temperature	$T_{S, O}$	-40	+85	°C	
Peak Forward Input Current	$I_{F, PK}$		90	mA	1
Average Forward Input Current	$I_{F, AVG}$		60	mA	
Reverse Input Voltage	$V_R$		3	V	
Lead Soldering Cycle Temp	$T_{SOL}$		260	°C	2
Lead Soldering Cycle Time	$T_{SOL}$		10	s	

#### Notes:

- For  $I_{F, PK} > 60$  mA, the duty factor must maintain  $I_{F, AVG} \leq 60$  mA and pulse width  $\leq 1$   $\mu$ s.
- 1.6 mm below seating plane.

### Electrical Characteristics Table

0 °C to +70 °C unless otherwise noted.

Parameter	Symbol	Min	Typ <sup>1</sup>	Max	Unit	Condition	Notes
Optical Power Temperature Coefficient	$\Delta P_T / \Delta T$		-0.02		dB/°C		
Forward Voltage	$V_F$	1.8	2.1	2.65	V	$I_{F, dc} = 60$ mA	See Figure 2
Forward Voltage Temperature Coefficient	$\Delta V_F / \Delta T$		-1.8		mV/°C		See Figure 2
Breakdown Voltage	$V_{BR}$	3.0	13		V	$I_{F, dc} = -10$ $\mu$ A	
Peak Emission Wavelength	$\lambda_{PK}$	640	650	660	nm		See Figure 4
Full Width Half Max	FWHM		21	30	nm		See Figure 4
Diode Capacitance	$C_0$		60		pF	$V_F = 0$ V, $f = 1$ MHz	
Thermal Resistance	$\theta_{jc}$		140		°C/W		Notes 2, 3
Rise Time (10% to 90%)	$t_r$			15	ns	10% to 90% $I_F = 60$ mA	See Figure 6
Fall Time (90% to 10%)	$t_f$			15	ns		See Figure 6

#### Notes:

- Typical data are at +25 °C
- Thermal resistance is measured with the transmitter coupled to a connector assembly and fiber, and mounted on a printed circuit board.
- To further reduce the thermal resistance, the cathode trace should be made as large as is consistent with good RF circuit design.
- Pins 1 and 4 are for mounting and retaining purposes, but are electrically connected, pins 5 and 6 are electrically isolated. It is recommended that pins 1, 4, 5 and 6 all be connected to ground to reduce coupling of electrical noise.

### Peak Output Power

0 °C to +70 °C unless otherwise noted.

Model Number	Symbol	Min	Max	Unit	Condition	Reference
HFBR-1506AM	Pr	-6.0 -18.0	-2.0 -10.0	dBm	POF, $I_{F,dc} = 60$ mA HCS®, $I_{F,dc} = 60$ mA	Note 1 Figure 3

#### Notes:

- Optical power measured at the end of 1 meters of 1 mm diameter plastic or 200  $\mu$ m hard/plastic clad silica optical fiber with a large area detector.

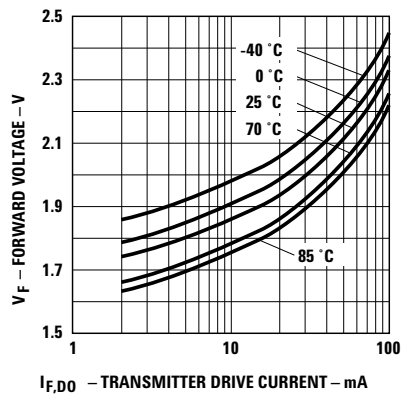

Figure 2. Typical Forward Voltage vs Drive Current

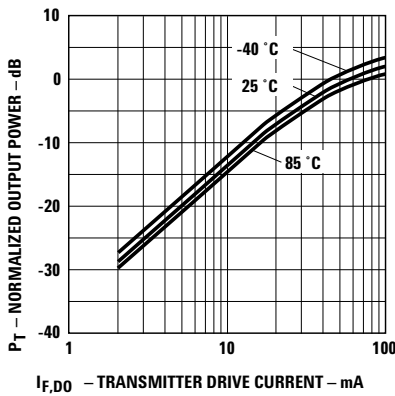

Figure 3. Typical Normalized Optical Power vs Drive Current

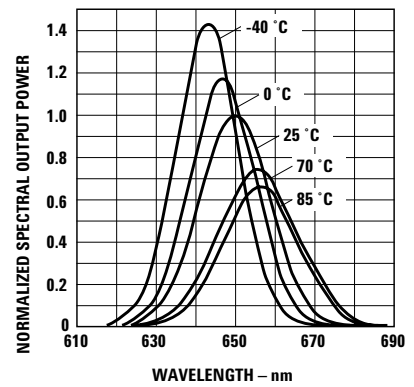

Figure 4. Typical Normalized Optical Spectra vs Drive Current

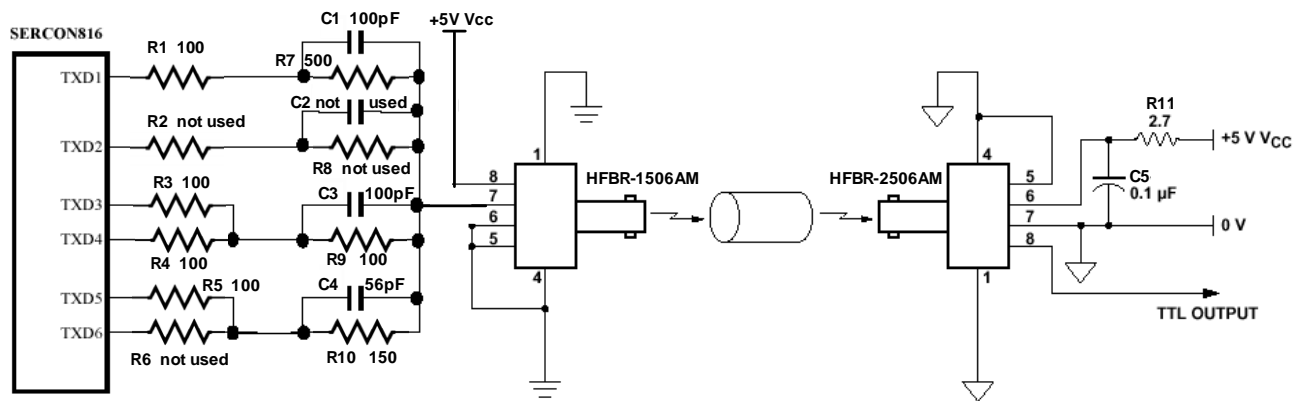
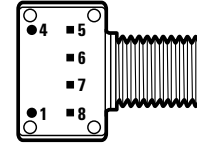

Figure 5. Recommended drive circuit according to SERCOS An17 ( $I_{fnom} \sim 35$  mA)

### HFBR-2506AM Receiver

The HFBR-2506AM receiver is housed in a metal-coated, plastic package, consists of a silicon PIN photodiode and digitizing IC to produce a logic compatible output. The IC includes a unique circuit to correct the pulse width distortion of the first bit after a long idle period. This enables operation from DC to 16MBd with low PWD for arbitrary data patterns.

The receiver is a "push-pull" stage compatible with TTL and CMOS logic. The HFBR-2506AM is compatible with SMA connectors.



BOTTOM VIEW,  
HFBR-2506AM

SEE NOTE 3

PIN	FUNCTION
1	CONNECTED TO PIN 4
4	CONNECTED TO PIN 1
5	NO CONNECT
6	VCC
7	GND
8	VO

Figure 6.

### Absolute Maximum Ratings

Parameter	Symbol	Min	Max	Unit	Notes
Storage and Operating Temperature	$T_{S, O}$	-40	+85	°C	
Supply Voltage	$V_{CC}$	-0.5	5.5	V	
Average Output Current	$I_{O, AVG}$		16	mA	
Output Power Dissipation	$P_{OD}$		80	mW	
Lead Soldering Cycle Temp	$T_{SOL}$		260	°C	1
Lead Soldering Cycle Time	$T_{SOL}$		10	s	

#### Notes:

- 1.6 mm below seating plane.

### Electrical Characteristics Table

0 °C to +70 °C, 4.75 V <  $V_{CC}$  < 5.25 V,  $V_{P,P}$  Noise <= 100 mV unless otherwise noted.

Parameter	Symbol	Min	Typ <sup>1</sup>	Max	Unit	Condition	Notes
Peak Input Power Level Logic HIGH	$P_{RH}$			-42 -44	dBm	1 mm POF 200 $\mu$ m HCS	
Peak Input Power Level Logic LOW	$P_{RL}$	-20 -22		-2 -10	dBm	1 mm POF 200 $\mu$ m HCS  PWD  < 19 ns	2
Supply Current	$I_{CC}$		27	45	mA	$V_O = \text{Open}$	
High Level Output Voltage	$V_{OH}$	4.2	4.7		V	$I_O = 40 \mu$ A	
Low Level Output Voltage	$V_{OH}$		0.22	0.4	V	$I_O = 1.6$ mA	
Pulse Width Distortion	PWD	-19		19	ns		
Propagation Delay Time	$T_{P,HL}$ or $T_{P,LH}$			150	ns		

#### Notes:

- Typical data are at +25 °C,  $V_{CC} = 5.0$  V
- BER <= 10E-9, includes a 10.8 dB margin below the receiver switching threshold level (signal to noise ratio =12)
- Pins 1 and 4 are for mounting and retaining purposes, but are electrically connected, pins 5 and 6 are electrically isolated. It is recommended that pins 1, 4, 5 and 6 all be connected to ground to reduce coupling of electrical noise

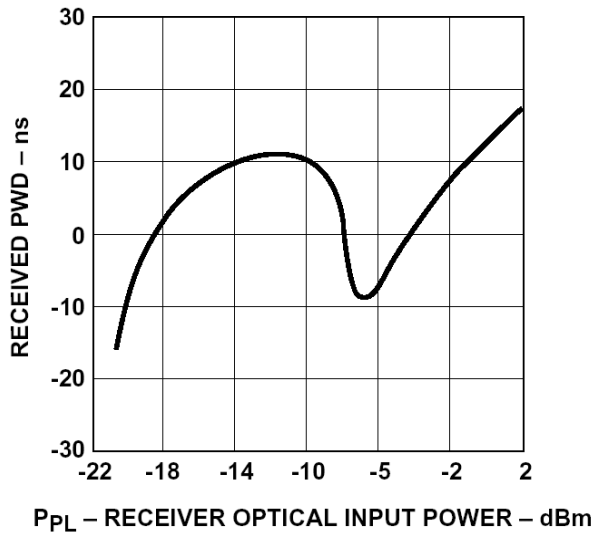

Figure 7. Typical POF receiver pulse width distortion vs optical power

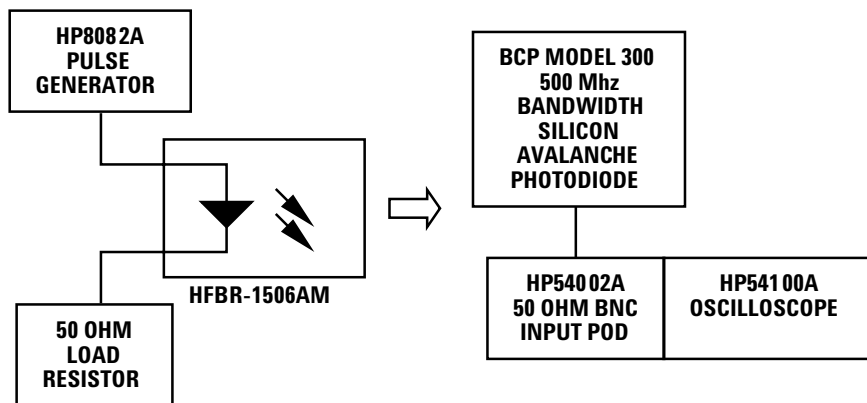
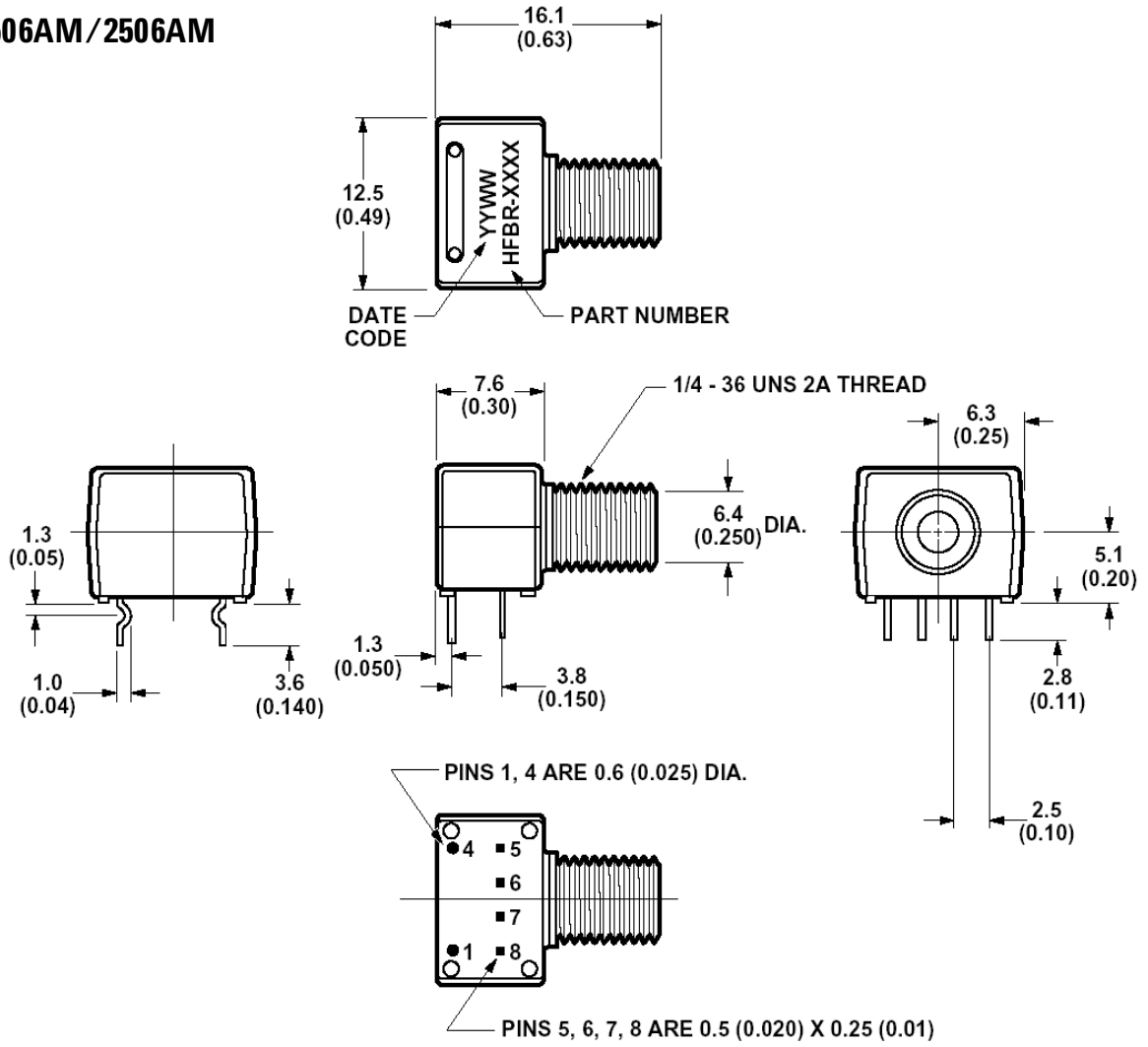

Figure 8. Test Circuit for Measuring Unpeaked Rise and Fall Times

**Mechanical Dimensions**

**HFBR-1506AM/2506AM**



**[www.agilent.com/  
semiconductors](http://www.agilent.com/semiconductors)**

For product information and a complete list of distributors, please go to our web site.

For technical assistance call:

Americas/Canada: +1 (800) 235-0312 or  
(408) 654-8675

Europe: +49 (0) 6441 92460

China: 10800 650 0017

Hong Kong: (+65) 6271 2451

India, Australia, New Zealand: (+65) 6271 2394

Japan: (+81 3) 3335-8152(Domestic/International), or  
0120-61-1280(Domestic Only)

Korea: (+65) 6271 2194

Malaysia, Singapore: (+65) 6271 2054

Taiwan: (+65) 6271 2654

Data subject to change.

Copyright © 2003 Agilent Technologies, Inc.

Obsoletes: 5988-8402EN

March 20, 2003

5988-9121EN



**Agilent Technologies**