

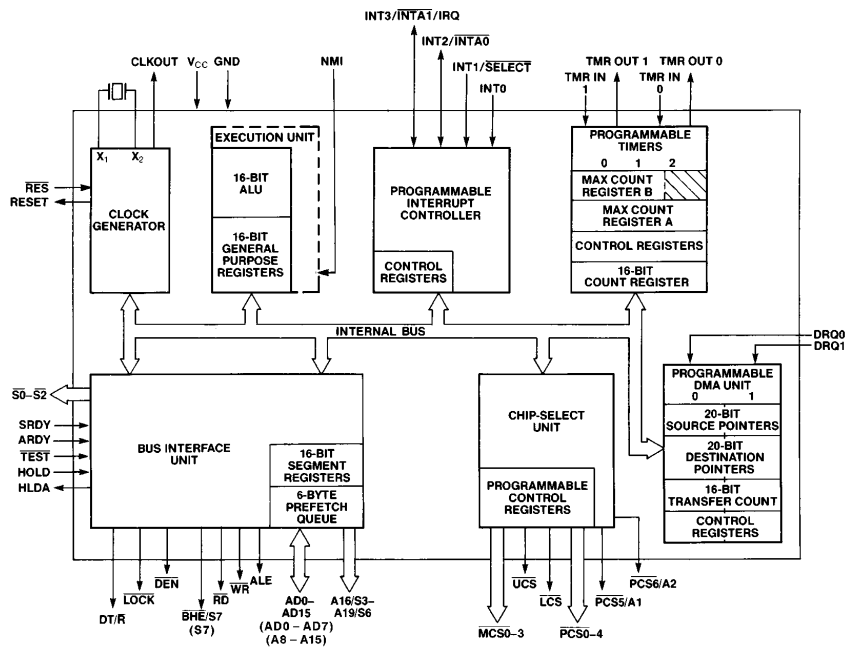

80186/80188 HIGH-INTEGRATION 16-BIT MICROPROCESSORS

- **Integrated Feature Set**
 - Enhanced 8086-2 CPU
 - Clock Generator
 - 2 Independent DMA Channels
 - Programmable Interrupt Controller
 - 3 Programmable 16-bit Timers
 - Programmable Memory and Peripheral Chip-Select Logic
 - Programmable Wait State Generator
 - Local Bus Controller
- **Available in 10 MHz and 8 MHz Versions**
- **High-Performance Processor**
 - 4 Mbyte/Sec Bus Bandwidth Interface @ 8 MHz (80186)
 - 5 Mbyte/Sec Bus Bandwidth Interface @ 10 MHz (80186)
- **Direct Addressing Capability to 1 Mbyte of Memory and 64 Kbyte I/O**
- **Completely Object Code Compatible with All Existing 8086, 8088 Software**
 - 10 New Instruction Types
- **Numerics Coprocessing Capability Through 8087 Interface**
- **Available in 68 Pin:**
 - Plastic Leaded Chip Carrier (PLCC)
 - Ceramic Pin Grid Array (PGA)
 - Ceramic Leadless Chip Carrier (LCC)
- **Available in EXPRESS**
 - Standard Temperature with Burn-In
 - Extended Temperature Range (−40°C to +85°C)



272430-1

Figure 1. Block Diagram

*Other brands and names are the property of their respective owners. Information in this document is provided in connection with Intel products. Intel assumes no liability whatsoever, including infringement of any patent or copyright, for sale and use of Intel products except as provided in Intel's Terms and Conditions of Sale for such products. Intel retains the right to make changes to these specifications at any time, without notice. Microcomputer Products may have minor variations to this specification known as errata.

November 1994

Order Number: 272430-002

COPYRIGHT © INTEL CORPORATION, 1995

80186/80188 High-Integration 16-Bit Microprocessors

CONTENTS	PAGE	CONTENTS	PAGE
FUNCTIONAL DESCRIPTION	9	ABSOLUTE MAXIMUM RATINGS	15
Introduction	9	D.C. CHARACTERISTICS	15
CLOCK GENERATOR	9	A.C. CHARACTERISTICS	16
Oscillator	9	EXPLANATION OF THE AC	
Clock Generator	9	SYMBOLS	18
READY Synchronization	9	WAVEFORMS	19
RESET Logic	9	EXPRESS	25
LOCAL BUS CONTROLLER	9	EXECUTION TIMINGS	26
Memory/Peripheral Control	10	INSTRUCTION SET SUMMARY	27
Local Bus Arbitration	10	FOOTNOTES	32
Local Bus Controller and Reset	10	REVISION HISTORY	33
PERIPHERAL ARCHITECTURE	10		
Chip-Select/Ready Generation Logic	10		
DMA Channels	11		
Timers	11		
Interrupt Controller	12		

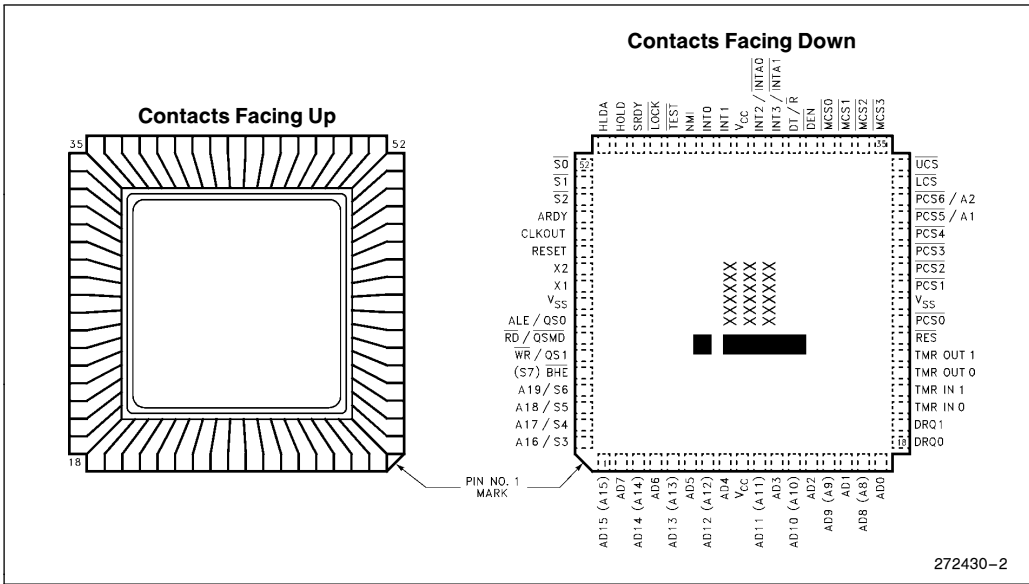

Figure 2. Ceramic Leadless Chip Carrier (JEDEC Type A)

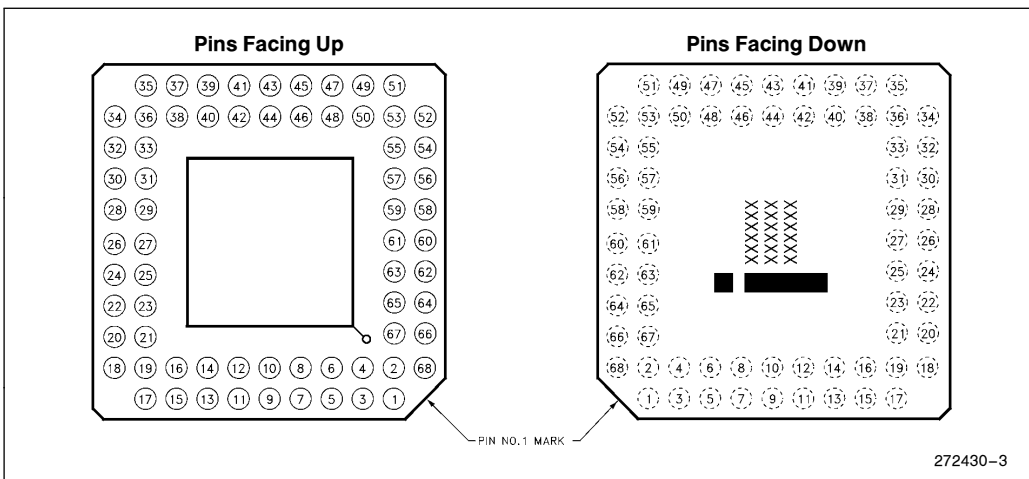

Figure 3. Ceramic Pin Grid Array

NOTE:
Pin names in parentheses apply to the 80188.

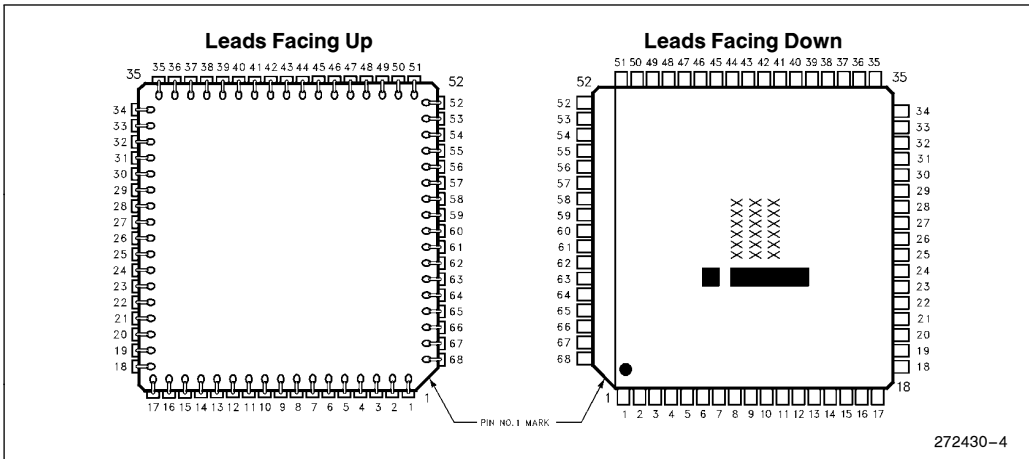

Figure 4. Plastic Leaded Chip Carrier

NOTE:

Pin names in parentheses apply to the 80188.

Table 1. Pin Descriptions

Symbol	Pin No.	Type	Name and Function
V _{CC}	9 43	I	SYSTEM POWER: + 5 volt power supply.
V _{SS}	26 60	I	System Ground.
RESET	57	O	Reset Output indicates that the CPU is being reset, and can be used as a system reset. It is active HIGH, synchronized with the processor clock, and lasts an integer number of clock periods corresponding to the length of the RES signal.
X1 X2	59 58	I O	Crystal Inputs X1 and X2 provide external connections for a fundamental mode parallel resonant crystal for the internal oscillator. Instead of using a crystal, an external clock may be applied to X1 while minimizing stray capacitance on X2. The input or oscillator frequency is internally divided by two to generate the clock signal (CLKOUT).
CLKOUT	56	O	Clock Output provides the system with a 50% duty cycle waveform. All device pin timings are specified relative to CLKOUT.
RES	24	I	An active RES causes the processor to immediately terminate its present activity, clear the internal logic, and enter a dormant state. This signal may be asynchronous to the processor clock. The processor begins fetching instructions approximately 6½ clock cycles after RES is returned HIGH. For proper initialization, V _{CC} must be within specifications and the clock signal must be stable for more than 4 clocks with RES held LOW. RES is internally synchronized. This input is provided with a Schmitt-trigger to facilitate power-on RES generation via an RC network.
TEST	47	I/O	TEST is examined by the WAIT instruction. If the TEST input is HIGH when "WAIT" execution begins, instruction execution will suspend. TEST will be resampled until it goes LOW, at which time execution will resume. If interrupts are enabled while the processor is waiting for TEST, interrupts will be serviced. During power-up, active RES is required to configure TEST as an input. This pin is synchronized internally.
TMR IN 0 TMR IN 1	20 21	I I	Timer Inputs are used either as clock or control signals, depending upon the programmed timer mode. These inputs are active HIGH (or LOW-to-HIGH transitions are counted) and internally synchronized.
TMR OUT 0 TMR OUT 1	22 23	O O	Timer outputs are used to provide single pulse or continuous waveform generation, depending upon the timer mode selected.
DRQ0 DRQ1	18 19	I I	DMA Request is asserted HIGH by an external device when it is ready for DMA Channel 0 or 1 to perform a transfer. These signals are level-triggered and internally synchronized.
NMI	46	I	The Non-Maskable Interrupt input causes a Type 2 interrupt. An NMI transition from LOW to HIGH is latched and synchronized internally, and initiates the interrupt at the next instruction boundary. NMI must be asserted for at least one clock. The Non-Maskable Interrupt cannot be avoided by programming.
INT0 INT1/SELECT INT2/INTA0 INT3/INTA1/IRQ	45 44 42 41	I I I/O I/O	Maskable Interrupt Requests can be requested by activating one of these pins. When configured as inputs, these pins are active HIGH. Interrupt Requests are synchronized internally. INT2 and INT3 may be configured to provide active-LOW interrupt-acknowledge output signals. All interrupt inputs may be configured to be either edge- or level-triggered. To ensure recognition, all interrupt requests must remain active until the interrupt is acknowledged. When Slave Mode is selected, the function of these pins changes (see Interrupt Controller section of this data sheet).

NOTE:

Pin names in parentheses apply to the 80188.

Table 1. Pin Descriptions (Continued)

Symbol	Pin No.	Type	Name and Function															
A19/S6 A18/S5 A17/S4 A16/S3	65 66 67 68	O O O O	Address Bus Outputs (16–19) and Bus Cycle Status (3–6) indicate the four most significant address bits during T ₁ . These signals are active HIGH. During T ₂ , T ₃ , T _W , and T ₄ , the S6 pin is LOW to indicate a CPU-initiated bus cycle or HIGH to indicate a DMA-initiated bus cycle. During the same T-states, S3, S4, and S5 are always LOW. The status pins float during bus HOLD or RESET.															
AD15 (A15) AD14 (A14) AD13 (A13) AD12 (A12) AD11 (A11) AD10 (A10) AD9 (A9) AD8 (A8) AD7 AD6 AD5 AD4 AD3 AD2 AD1 AD0	1 3 5 7 10 12 14 16 2 4 6 8 11 13 15 17	I/O I/O I/O I/O I/O I/O I/O I/O I/O I/O I/O I/O I/O I/O I/O	Address/Data Bus signals constitute the time multiplexed memory or I/O address (T ₁) and data (T ₂ , T ₃ , T _W , and T ₄) bus. The bus is active HIGH. A ₀ is analogous to BHE for the lower byte of the data bus, pins D ₇ through D ₀ . It is LOW during T ₁ when a byte is to be transferred onto the lower portion of the bus in memory or I/O operations. BHE does not exist on the 80188, as the data bus is only 8 bits wide.															
$\overline{\text{BHE}}/\text{S7}$ (S7)	64	O	During T ₁ the Bus High Enable signal should be used to determine if data is to be enabled onto the most significant half of the data bus; pins D ₁₅ –D ₈ . $\overline{\text{BHE}}$ is LOW during T ₁ for read, write, and interrupt acknowledge cycles when a byte is to be transferred on the higher half of the bus. The S ₇ status information is available during T ₂ , T ₃ , and T ₄ . S ₇ is logically equivalent to $\overline{\text{BHE}}$. $\overline{\text{BHE}}/\text{S7}$ floats during HOLD. On the 80188, S ₇ is high during normal operation.															
			$\overline{\text{BHE}}$ and A0 Encodings (80186 Only)															
			<table border="1"> <thead> <tr> <th>$\overline{\text{BHE}}$ Value</th> <th>A0 Value</th> <th>Function</th> </tr> </thead> <tbody> <tr> <td>0</td> <td>0</td> <td>Word Transfer</td> </tr> <tr> <td>0</td> <td>1</td> <td>Byte Transfer on upper half of data bus (D₁₅–D₈)</td> </tr> <tr> <td>1</td> <td>0</td> <td>Byte Transfer on lower half of data bus (D₇–D₀)</td> </tr> <tr> <td>1</td> <td>1</td> <td>Reserved</td> </tr> </tbody> </table>	$\overline{\text{BHE}}$ Value	A0 Value	Function	0	0	Word Transfer	0	1	Byte Transfer on upper half of data bus (D ₁₅ –D ₈)	1	0	Byte Transfer on lower half of data bus (D ₇ –D ₀)	1	1	Reserved
$\overline{\text{BHE}}$ Value	A0 Value	Function																
0	0	Word Transfer																
0	1	Byte Transfer on upper half of data bus (D ₁₅ –D ₈)																
1	0	Byte Transfer on lower half of data bus (D ₇ –D ₀)																
1	1	Reserved																
ALE/QS0	61	O	Address Latch Enable/Queue Status 0 is provided by the processor to latch the address. ALE is active HIGH. Addresses are guaranteed to be valid on the trailing edge of ALE. The ALE rising edge is generated off the rising edge of the CLKOUT immediately preceding T ₁ of the associated bus cycle, effectively one-half clock cycle earlier than in the 8086. The trailing edge is generated off the CLKOUT rising edge in T ₁ as in the 8086. Note that ALE is never floated.															
$\overline{\text{WR}}/\text{QS1}$	63	O	Write Strobe/Queue Status 1 indicates that the data on the bus is to be written into a memory or an I/O device. $\overline{\text{WR}}$ is active for T ₂ , T ₃ , and T _W of any write cycle. It is active LOW, and floats during HOLD. When the processor is in queue status mode, the ALE/QS0 and $\overline{\text{WR}}/\text{QS1}$ pins provide information about processor/instruction queue interaction.															
			<table border="1"> <thead> <tr> <th>QS1</th> <th>QS0</th> <th>Queue Operation</th> </tr> </thead> <tbody> <tr> <td>0</td> <td>0</td> <td>No queue operation</td> </tr> <tr> <td>0</td> <td>1</td> <td>First opcode byte fetched from the queue</td> </tr> <tr> <td>1</td> <td>1</td> <td>Subsequent byte fetched from the queue</td> </tr> <tr> <td>1</td> <td>0</td> <td>Empty the queue</td> </tr> </tbody> </table>	QS1	QS0	Queue Operation	0	0	No queue operation	0	1	First opcode byte fetched from the queue	1	1	Subsequent byte fetched from the queue	1	0	Empty the queue
QS1	QS0	Queue Operation																
0	0	No queue operation																
0	1	First opcode byte fetched from the queue																
1	1	Subsequent byte fetched from the queue																
1	0	Empty the queue																

NOTE:

Pin names in parentheses apply to the 80188.

Table 1. Pin Descriptions (Continued)

Symbol	Pin No.	Type	Name and Function																																								
$\overline{RD}/\overline{QSMD}$	62	I/O	Read Strobe is an active LOW signal which indicates that the processor is performing a memory or I/O read cycle. It is guaranteed not to go LOW before the A/D bus is floated. An internal pull-up ensures that \overline{RD} is HIGH during RESET. Following RESET the pin is sampled to determine whether the processor is to provide ALE, \overline{RD} , and \overline{WR} , or queue status information. To enable Queue Status Mode, \overline{RD} must be connected to GND. \overline{RD} will float during bus HOLD.																																								
ARDY	55	I	Asynchronous Ready informs the processor that the addressed memory space or I/O device will complete a data transfer. The ARDY pin accepts a rising edge that is asynchronous to CLKOUT, and is active HIGH. The falling edge of ARDY must be synchronized to the processor clock. Connecting ARDY HIGH will always assert the ready condition to the CPU. If this line is unused, it should be tied LOW to yield control to the SRDY pin.																																								
SRDY	49	I	Synchronous Ready informs the processor that the addressed memory space or I/O device will complete a data transfer. The SRDY pin accepts an active-HIGH input synchronized to CLKOUT. The use of SRDY allows a relaxed system timing over ARDY. This is accomplished by elimination of the one-half clock cycle required to internally synchronize the ARDY input signal. Connecting SRDY high will always assert the ready condition to the CPU. If this line is unused, it should be tied LOW to yield control to the ARDY pin.																																								
\overline{LOCK}	48	O	\overline{LOCK} output indicates that other system bus masters are not to gain control of the system bus while \overline{LOCK} is active LOW. The \overline{LOCK} signal is requested by the LOCK prefix instruction and is activated at the beginning of the first data cycle associated with the instruction following the LOCK prefix. It remains active until the completion of that instruction. No instruction prefetching will occur while \overline{LOCK} is asserted. When executing more than one LOCK instruction, always make sure there are 6 bytes of code between the end of the first LOCK instruction and the start of the second LOCK instruction. \overline{LOCK} is driven HIGH for one clock during RESET and then floated.																																								
$\overline{S0}$ $\overline{S1}$ $\overline{S2}$	52 53 54	O O O	<p>Bus cycle status $\overline{S0}$–$\overline{S2}$ are encoded to provide bus-transaction information:</p> <table border="1" style="width: 100%; border-collapse: collapse;"> <thead> <tr> <th colspan="4" style="text-align: center;">Bus Cycle Status Information</th> </tr> <tr> <th style="text-align: center;">$\overline{S2}$</th> <th style="text-align: center;">$\overline{S1}$</th> <th style="text-align: center;">$\overline{S0}$</th> <th style="text-align: center;">Bus Cycle Initiated</th> </tr> </thead> <tbody> <tr> <td style="text-align: center;">0</td> <td style="text-align: center;">0</td> <td style="text-align: center;">0</td> <td>Interrupt Acknowledge</td> </tr> <tr> <td style="text-align: center;">0</td> <td style="text-align: center;">0</td> <td style="text-align: center;">1</td> <td>Read I/O</td> </tr> <tr> <td style="text-align: center;">0</td> <td style="text-align: center;">1</td> <td style="text-align: center;">0</td> <td>Write I/O</td> </tr> <tr> <td style="text-align: center;">0</td> <td style="text-align: center;">1</td> <td style="text-align: center;">1</td> <td>Halt</td> </tr> <tr> <td style="text-align: center;">1</td> <td style="text-align: center;">0</td> <td style="text-align: center;">0</td> <td>Instruction Fetch</td> </tr> <tr> <td style="text-align: center;">1</td> <td style="text-align: center;">0</td> <td style="text-align: center;">1</td> <td>Read Data from Memory</td> </tr> <tr> <td style="text-align: center;">1</td> <td style="text-align: center;">1</td> <td style="text-align: center;">0</td> <td>Write Data to Memory</td> </tr> <tr> <td style="text-align: center;">1</td> <td style="text-align: center;">1</td> <td style="text-align: center;">1</td> <td>Passive (no bus cycle)</td> </tr> </tbody> </table> <p>The status pins float during HOLD. $\overline{S2}$ may be used as a logical M/\overline{IO} indicator, and $\overline{S1}$ as a DT/\overline{R} indicator.</p>	Bus Cycle Status Information				$\overline{S2}$	$\overline{S1}$	$\overline{S0}$	Bus Cycle Initiated	0	0	0	Interrupt Acknowledge	0	0	1	Read I/O	0	1	0	Write I/O	0	1	1	Halt	1	0	0	Instruction Fetch	1	0	1	Read Data from Memory	1	1	0	Write Data to Memory	1	1	1	Passive (no bus cycle)
Bus Cycle Status Information																																											
$\overline{S2}$	$\overline{S1}$	$\overline{S0}$	Bus Cycle Initiated																																								
0	0	0	Interrupt Acknowledge																																								
0	0	1	Read I/O																																								
0	1	0	Write I/O																																								
0	1	1	Halt																																								
1	0	0	Instruction Fetch																																								
1	0	1	Read Data from Memory																																								
1	1	0	Write Data to Memory																																								
1	1	1	Passive (no bus cycle)																																								

NOTE:

Pin names in parentheses apply to the 80188.

Table 1. Pin Descriptions (Continued)

Symbol	Pin No.	Type	Name and Function
HOLD HLDA	50 51	I O	HOLD indicates that another bus master is requesting the local bus. The HOLD input is active HIGH. HOLD may be asynchronous with respect to the processor clock. The processor will issue a HLDA (HIGH) in response to a HOLD request at the end of T ₄ or T _i . Simultaneous with the issuance of HLDA, the processor will float the local bus and control lines. After HOLD is detected as being LOW, the processor will lower HLDA. When the processor needs to run another bus cycle, it will again drive the local bus and control lines.
\overline{UCS}	34	O	Upper Memory Chip Select is an active LOW output whenever a memory reference is made to the defined upper portion (1K–256K block) of memory. This line is not floated during bus HOLD. The address range activating \overline{UCS} is software programmable.
\overline{LCS}	33	O	Lower Memory Chip Select is active LOW whenever a memory reference is made to the defined lower portion (1K–256K) of memory. This line is not floated during bus HOLD. The address range activating \overline{LCS} is software programmable.
$\overline{MCS0}$ $\overline{MCS1}$ $\overline{MCS2}$ $\overline{MCS3}$	38 37 36 35	O O O O	Mid-Range Memory Chip Select signals are active LOW when a memory reference is made to the defined mid-range portion of memory (8K–512K). These lines are not floated during bus HOLD. The address ranges activating $\overline{MCS0}$ –3 are software programmable.
$\overline{PCS0}$ $\overline{PCS1}$ $\overline{PCS2}$ $\overline{PCS3}$ $\overline{PCS4}$	25 27 28 29 30	O O O O O	Peripheral Chip Select signals 0–4 are active LOW when a reference is made to the defined peripheral area (64 Kbyte I/O space). These lines are not floated during bus HOLD. The address ranges activating $\overline{PCS0}$ –4 are software programmable.
$\overline{PCS5/A1}$	31	O	Peripheral Chip Select 5 or Latched A1 may be programmed to provide a sixth peripheral chip select, or to provide an internally latched A1 signal. The address range activating $\overline{PCS5}$ is software-programmable. $\overline{PCS5/A1}$ does not float during bus HOLD. When programmed to provide latched A1, this pin will retain the previously latched value during HOLD.
$\overline{PCS6/A2}$	32	O	Peripheral Chip Select 6 or Latched A2 may be programmed to provide a seventh peripheral chip select, or to provide an internally latched A2 signal. The address range activating $\overline{PCS6}$ is software programmable. $\overline{PCS6/A2}$ does not float during bus HOLD. When programmed to provide latched A2, this pin will retain the previously latched value during HOLD.
$\overline{DT/R}$	40	O	Data Transmit/Receive controls the direction of data flow through an external data bus transceiver. When LOW, data is transferred to the processor. When HIGH, the processor places write data on the data bus.
\overline{DEN}	39	O	Data Enable is provided as a data bus transceiver output enable. \overline{DEN} is active LOW during each memory and I/O access. \overline{DEN} is HIGH whenever $\overline{DT/R}$ changes state. During RESET, \overline{DEN} is driven HIGH for one clock, then floated. \overline{DEN} also floats during HOLD.

NOTE:

Pin names in parentheses apply to the 80188.

FUNCTIONAL DESCRIPTION

Introduction

The following Functional Description describes the base architecture of the 80186. The 80186 is a very high integration 16-bit microprocessor. It combines 15–20 of the most common microprocessor system components onto one chip while providing twice the performance of the standard 8086. The 80186 is object code compatible with the 8086/8088 microprocessors and adds 10 new instruction types to the 8086/8088 instruction set.

For more detailed information on the architecture, please refer to the 80C186XL/80C188XL User's Manual. The 80186 and the 80186XL devices are functionally and register compatible.

CLOCK GENERATOR

The processor provides an on-chip clock generator for both internal and external clock generation. The clock generator features a crystal oscillator, a divide-by-two counter, synchronous and asynchronous ready inputs, and reset circuitry.

Oscillator

The oscillator circuit is designed to be used with a parallel resonant fundamental mode crystal. This is used as the time base for the processor. The crystal frequency selected will be double the CPU clock frequency. Use of an LC or RC circuit is not recommended with this oscillator. If an external oscillator is used, it can be connected directly to the input pin X1 in lieu of a crystal. The output of the oscillator is not directly available outside the processor. The recommended crystal configuration is shown in Figure 5.

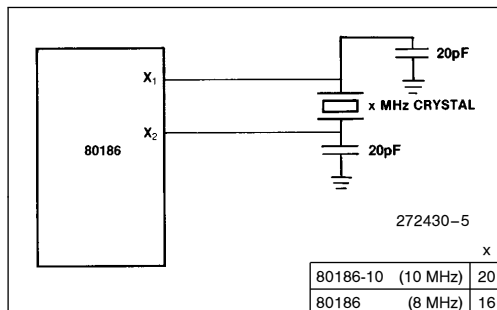

Figure 5. Recommended Crystal Configuration

Intel recommends the following values for crystal selection parameters:

Temperature Range:	0 to 70°C
ESR (Equivalent Series Resistance):	30Ω max
C ₀ (Shunt Capacitance of Crystal):	7.0 pf max
C ₁ (Load Capacitance):	20 pf ± 2 pf
Drive Level:	1 mW max

Clock Generator

The clock generator provides the 50% duty cycle processor clock for the processor. It does this by dividing the oscillator output by 2 forming the symmetrical clock. If an external oscillator is used, the state of the clock generator will change on the falling edge of the oscillator signal. The CLKOUT pin provides the processor clock signal for use outside the device. This may be used to drive other system components. All timings are referenced to the output clock.

READY Synchronization

The processor provides both synchronous and asynchronous ready inputs. In addition, the processor, as part of the integrated chip-select logic, has the capability to program WAIT states for memory and peripheral blocks.

RESET Logic

The processor provides both a $\overline{\text{RES}}$ input pin and a synchronized RESET output pin for use with other system components. The $\overline{\text{RES}}$ input pin is provided with hysteresis in order to facilitate power-on Reset generation via an RC network. RESET output is guaranteed to remain active for at least five clocks given a $\overline{\text{RES}}$ input of at least six clocks.

LOCAL BUS CONTROLLER

The processor provides a local bus controller to generate the local bus control signals. In addition, it employs a HOLD/HLDA protocol for relinquishing the local bus to other bus masters. It also provides outputs that can be used to enable external buffers and to direct the flow of data on and off the local bus.

Memory/Peripheral Control

The processor provides ALE, \overline{RD} , and \overline{WR} bus control signals. The \overline{RD} and \overline{WR} signals are used to strobe data from memory or I/O to the processor or to strobe data from the processor to memory or I/O. The ALE line provides a strobe to latch the address when it is valid. The local bus controller does not provide a memory/I/O signal. If this is required, use the $\overline{S2}$ signal (which will require external latching), make the memory and I/O spaces nonoverlapping, or use only the integrated chip-select circuitry.

Local Bus Arbitration

The processor uses a HOLD/HLDA system of local bus exchange. This provides an asynchronous bus exchange mechanism. This means multiple masters utilizing the same bus can operate at separate clock frequencies. The processor provides a single HOLD/HLDA pair through which all other bus masters may gain control of the local bus. External circuitry must arbitrate which external device will gain control of the bus when there is more than one alternate local bus master. When the processor relinquishes control of the local bus, it floats DEN, RD, \overline{WR} , $\overline{S0}$ – $\overline{S2}$, \overline{LOCK} , AD0–AD15 (AD0–AD7), A16–A19 (A8–A19), BHE (S7), and DT/R to allow another master to drive these lines directly.

Local Bus Controller and Reset

During RESET the local bus controller will perform the following action:

- Drive DEN, RD, and \overline{WR} HIGH for one clock cycle, then float.

NOTE:

\overline{RD} is also provided with an internal pull-up device to prevent the processor from inadvertently entering Queue Status Mode during RESET.

- Drive $\overline{S0}$ – $\overline{S2}$ to the inactive state (all HIGH) and then float.
- Drive \overline{LOCK} HIGH and then float.
- Float AD0–15 (AD0–AD7), A16–19 (A8–A19), BHE (S7), DT/R.
- Drive ALE LOW (ALE is never floated).
- Drive HLDA LOW.

PERIPHERAL ARCHITECTURE

All of the integrated peripherals are controlled by 16-bit registers contained within an internal 256-byte control block. The control block may be mapped into

either memory or I/O space. Internal logic will recognize control block addresses and respond to bus cycles. During bus cycles to internal registers, the bus controller will signal the operation externally (i.e., the RD, WR, status, address, data, etc., lines will be driven as in a normal bus cycle), but D_{15–0} (D_{7–0}), SRDY, and ARDY will be ignored. The base address of the control block must be on an even 256-byte boundary (i.e., the lower 8 bits of the base address are all zeros).

The control block base address is programmed by a 16-bit relocation register contained within the control block at offset FEH from the base address of the control block. It provides the upper 12 bits of the base address of the control block.

In addition to providing relocation information for the control block, the relocation register contains bits which place the interrupt controller into Slave Mode, and cause the CPU to interrupt upon encountering ESC instructions.

Chip-Select/Ready Generation Logic

The processor contains logic which provides programmable chip-select generation for both memories and peripherals. In addition, it can be programmed to provide READY (or WAIT state) generation. It can also provide latched address bits A1 and A2. The chip-select lines are active for all memory and I/O cycles in their programmed areas, whether they be generated by the CPU or by the integrated DMA unit.

MEMORY CHIP SELECTS

The processor provides 6 memory chip select outputs for 3 address areas; upper memory, lower memory, and midrange memory. One each is provided for upper memory and lower memory, while four are provided for midrange memory.

UPPER MEMORY \overline{CS}

The processor provides a chip select, called \overline{UCS} , for the top of memory. The top of memory is usually used as the system memory because after reset the processor begins executing at memory location FFFF0H.

LOWER MEMORY \overline{CS}

The processor provides a chip select for low memory called \overline{LCS} . The bottom of memory contains the interrupt vector table, starting at location 00000H.

The lower limit of memory defined by this chip select is always 0H, while the upper limit is programmable. By programming the upper limit, the size of the memory block is defined.

MID-RANGE MEMORY \overline{CS}

The processor provides four \overline{MCS} lines which are active within a user-locatable memory block. This block can be located within the 1-Mbyte memory address space exclusive of the areas defined by \overline{UCS} and \overline{LCS} . Both the base address and size of this memory block are programmable.

PERIPHERAL CHIP SELECTS

The processor can generate chip selects for up to seven peripheral devices. These chip selects are active for seven contiguous blocks of 128 bytes above a programmable base address. The base address may be located in either memory or I/O space. Seven \overline{CS} lines called $\overline{PCS0}$ –6 are generated by the processor. $\overline{PCS5}$ and $\overline{PCS6}$ can also be programmed to provide latched address bits A1 and A2. If so programmed, they cannot be used as peripheral selects. These outputs can be connected directly to the A0 and A1 pins used for selecting internal registers of 8-bit peripheral chips.

READY GENERATION LOGIC

The processor can generate a READY signal internally for each of the memory or peripheral \overline{CS} lines. The number of WAIT states to be inserted for each peripheral or memory is programmable to provide 0–3 wait states for all accesses to the area for which the chip select is active. In addition, the processor may be programmed to either ignore external READY for each chip-select range individually or to factor external READY with the integrated ready generator.

CHIP SELECT/READY LOGIC AND RESET

Upon RESET, the Chip-Select/Ready Logic will perform the following actions:

- All chip-select outputs will be driven HIGH.

- Upon leaving RESET, the \overline{UCS} line will be programmed to provide chip selects to a 1K block with the accompanying READY control bits set at 011 to insert 3 wait states in conjunction with external READY (i.e., UMCS resets to FFFBH).
- No other chip select or READY control registers have any predefined values after RESET. They will not become active until the CPU accesses their control registers. Both the PACS and MPCS registers must be accessed before the \overline{PCS} lines will become active.

DMA Channels

The DMA controller provides two independent DMA channels. Data transfers can occur between memory and I/O spaces (e.g., Memory to I/O) or within the same space (e.g., Memory to Memory or I/O to I/O). Data can be transferred either in bytes or in words (80186 only) to or from even or odd addresses. Each DMA channel maintains both a 20-bit source and destination pointer which can be optionally incremented or decremented after each data transfer (by one or two depending on byte or word transfers). Each data transfer consumes 2 bus cycles (a minimum of 8 clocks), one cycle to fetch data and the other to store data. This provides a maximum data transfer rate of 1.25 Mword/sec or 2.5 Mbytes/sec at 10 MHz (half of this rate for the 80188).

DMA CHANNELS AND RESET

Upon RESET, the DMA channels will perform the following actions:

- The Start/Stop bit for each channel will be reset to STOP.
- Any transfer in progress is aborted.

Timers

The processor provides three internal 16-bit programmable timers. Two of these are highly flexible and are connected to four external pins (2 per timer). They can be used to count external events, time external events, generate nonrepetitive waveforms, etc. The third timer is not connected to any external pins, and is useful for real-time coding and time delay applications. In addition, the third timer can be used as a prescaler to the other two, or as a DMA request source.

TIMERS AND RESET

Upon RESET, the Timers will perform the following actions:

- All EN (Enable) bits are reset preventing timer counting.
- For Timers 0 and 1, the RIU bits are reset to zero and the ALT bits are set to one. This results in the Timer Out pins going high.

Interrupt Controller

The processor can receive interrupts from a number of sources, both internal and external. The internal interrupt controller serves to merge these requests on a priority basis, for individual service by the CPU.

Internal interrupt sources (Timers and DMA channels) can be disabled by their own control registers or by mask bits within the interrupt controller. The interrupt controller has its own control register that sets the mode of operation for the controller.

INTERRUPT CONTROLLER AND RESET

Upon RESET, the interrupt controller will perform the following actions:

- All SFNM bits reset to 0, implying Fully Nested Mode.
- All PR bits in the various control registers set to 1. This places all sources at lowest priority (level 111).
- All LTM bits reset to 0, resulting in edge-sense mode.
- All Interrupt Service bits reset to 0.
- All Interrupt Request bits reset to 0.
- All MSK (Interrupt Mask) bits set to 1 (mask).
- All C (Cascade) bits reset to 0 (non-Cascade).
- All PRM (Priority Mask) bits set to 1, implying no levels masked.
- Initialized to Master Mode.

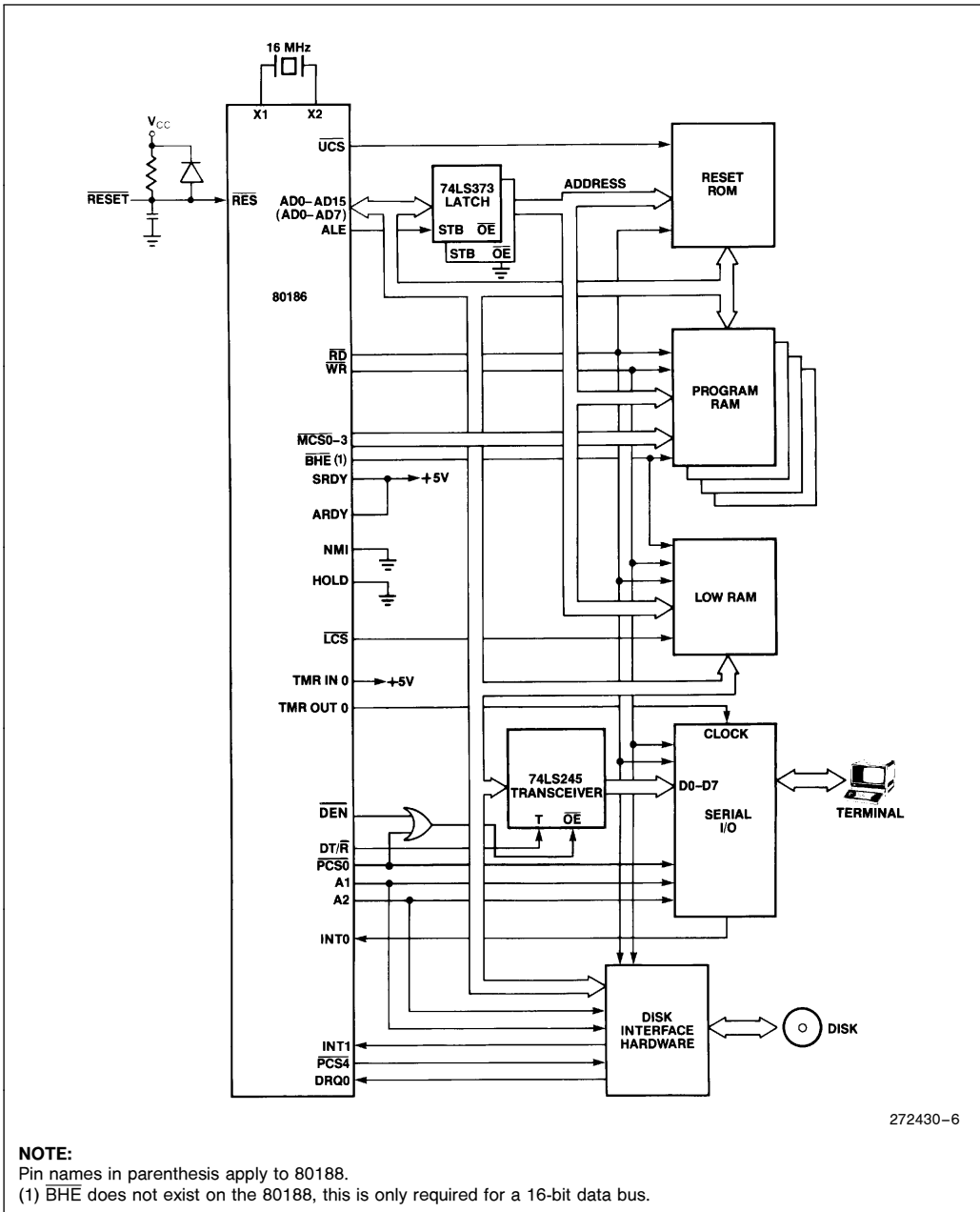

Figure 6. Typical 80186/80188 Computer

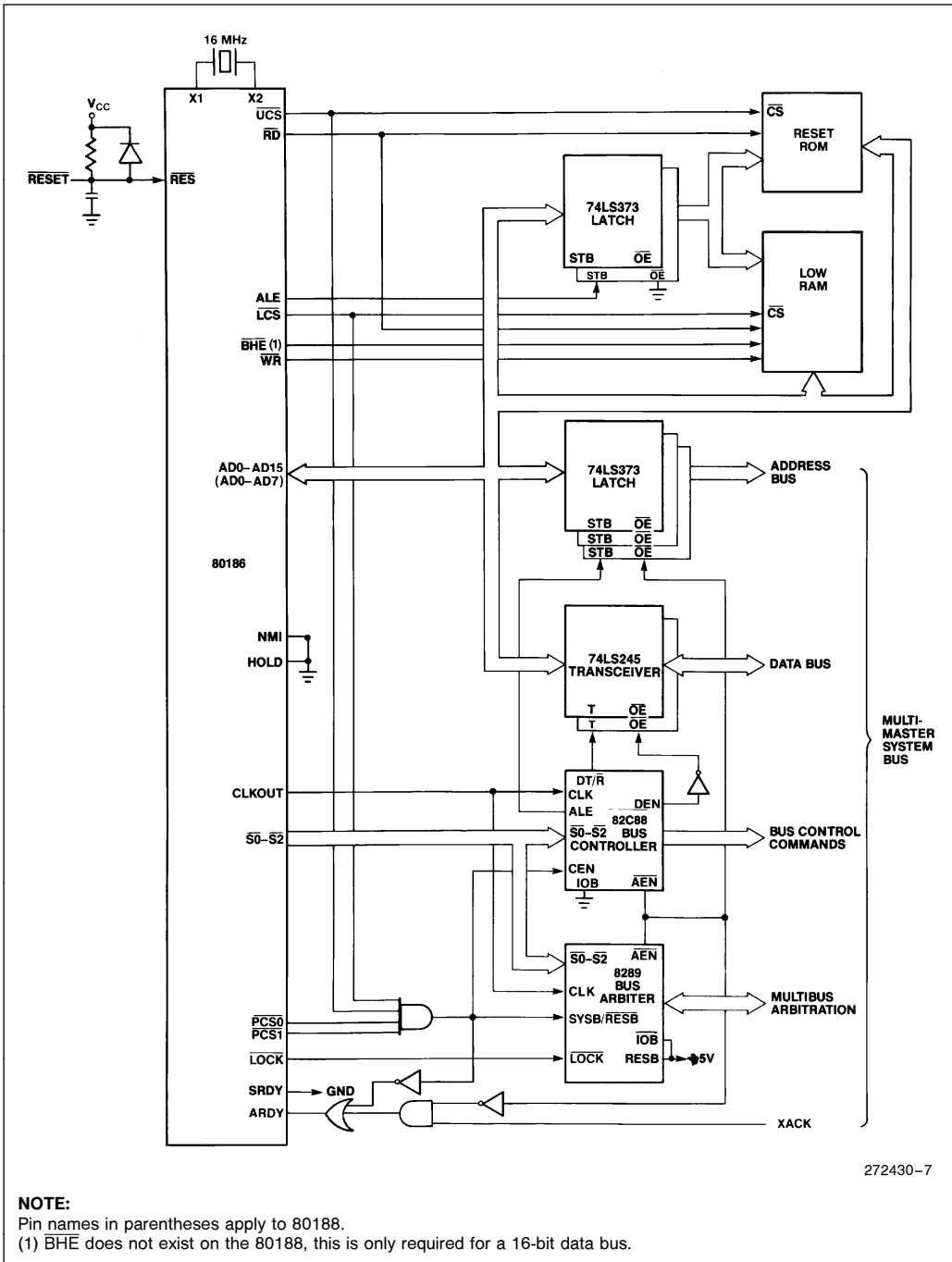

Figure 7. Typical 80186/80188 Multi-Master Bus Interface

ABSOLUTE MAXIMUM RATINGS*

Ambient Temperature under Bias0°C to 70°C
 Storage Temperature -65°C to +150°C
 Voltage on any Pin with
 Respect to Ground -1.0V to +7V
 Power Dissipation3W

NOTICE: This is a production data sheet. The specifications are subject to change without notice.

**WARNING: Stressing the device beyond the "Absolute Maximum Ratings" may cause permanent damage. These are stress ratings only. Operation beyond the "Operating Conditions" is not recommended and extended exposure beyond the "Operating Conditions" may affect device reliability.*

D.C. CHARACTERISTICS ($T_A = 0^\circ\text{C}$ to $+70^\circ\text{C}$, $V_{CC} = 5\text{V} \pm 10\%$)

Applicable to 8 MHz and 10 MHz devices.

Symbol	Parameter	Min	Max	Units	Test Conditions
V_{IL}	Input Low Voltage	-0.5	+0.8	V	
V_{IH}	Input High Voltage (All except X1 and $\overline{\text{RES}}$)	2.0	$V_{CC} + 0.5$	V	
V_{IH1}	Input High Voltage ($\overline{\text{RES}}$)	3.0	$V_{CC} + 0.5$	V	
V_{OL}	Output Low Voltage		0.45	V	$I_a = 2.5\text{ mA}$ for $\overline{\text{S0}}-\overline{\text{S2}}$ $I_a = 2.0\text{ mA}$ for all other Outputs
V_{OH}	Output High Voltage	2.4		V	$I_{oa} = -400\ \mu\text{A}$
I_{CC}	Power Supply Current		600*	mA	$T_A = -40^\circ\text{C}$
			550	mA	$T_A = 0^\circ\text{C}$
			415	mA	$T_A = +70^\circ\text{C}$
I_{LI}	Input Leakage Current		± 10	μA	$0\text{V} < V_{IN} < V_{CC}$
I_{LO}	Output Leakage Current		± 10	μA	$0.45\text{V} < V_{OUT} < V_{CC}$
V_{CLO}	Clock Output Low		0.6	V	$I_a = 4.0\text{ mA}$
V_{CHO}	Clock Output High	4.0		V	$I_{oa} = -200\ \mu\text{A}$
V_{CLI}	Clock Input Low Voltage	-0.5	0.6	V	
V_{CHI}	Clock Input High Voltage	3.9	$V_{CC} + 1.0$	V	
C_{IN}	Input Capacitance		10	pF	
C_{IO}	I/O Capacitance		20	pF	

*For extended temperature parts only.

A.C. CHARACTERISTICS ($T_A = 0^\circ\text{C}$ to $+70^\circ\text{C}$, $V_{CC} = 5\text{V} \pm 10\%$)

Timing Requirements All Timings Measured At 1.5V Unless Otherwise Noted.

Symbol	Parameter	8 MHz		10 MHz		Units	Test Conditions
		Min	Max	Min	Max		
T_{DVCL}	Data in Setup (A/D)	20		15		ns	
T_{CLDX}	Data in Hold (A/D)	10		8		ns	
T_{ARYHCH}	Asynchronous Ready (ARDY) Active Setup Time ⁽¹⁾	20		15		ns	
T_{ARYLCL}	ARDY Inactive Setup Time	35		25		ns	
T_{CLARX}	ARDY Hold Time	15		15		ns	
T_{ARYCHL}	Asynchronous Ready Inactive Hold Time	15		15		ns	
T_{SRYCL}	Synchronous Ready (SRDY) Transition Setup Time ⁽²⁾	20		20		ns	
T_{CLSRV}	SRDY Transition Hold Time ⁽²⁾	15		15		ns	
T_{HVCL}	HOLD Setup ⁽¹⁾	25		20		ns	
T_{INVCH}	INTR, NMI, $\overline{\text{TEST}}$, TIM IN, Setup ⁽¹⁾	25		25		ns	
T_{INVCL}	DRQ0, DRQ1, Setup ⁽¹⁾	25		20		ns	

Master Interface Timing Responses

T_{CLAV}	Address Valid Delay	5	55	5	44	ns	$C_L = 20\text{ pF} - 200\text{ pF}$ all Outputs (Except T_{CLTMV}) @ 8 MHz and 10 MHz
T_{CLAX}	Address Hold	10		10		ns	
T_{CLAZ}	Address Float Delay	T_{CLAX}	35	T_{CLAX}	30	ns	
T_{CHCZ}	Command Lines Float Delay		45		40	ns	
T_{CHCV}	Command Lines Valid Delay (after Float)		55		45	ns	
T_{LHLL}	ALE Width	$T_{CLCL} - 35$		$T_{CLCL} - 30$		ns	
T_{CHLH}	ALE Active Delay		35		30	ns	
T_{CHLL}	ALE Inactive Delay		35		30	ns	
T_{LLAX}	Address Hold from ALE Inactive	$T_{CHCL} - 25$		$T_{CHCL} - 20$		ns	
T_{CLDV}	Data Valid Delay	10	44	10	40	ns	
T_{CLDOX}	Data Hold Time	10		10		ns	
T_{WHDX}	Data Hold after WR	$T_{CLCL} - 40$		$T_{CLCL} - 34$		ns	
T_{CVCTV}	Control Active Delay 1	5	50	5	40	ns	
T_{CHCTV}	Control Active Delay 2	10	55	10	44	ns	
T_{CVCTX}	Control Inactive Delay	5	55	5	44	ns	
T_{CVDEX}	$\overline{\text{DEN}}$ Inactive Delay (Non-Write Cycle)	10	70	10	56	ns	

1. To guarantee recognition at next clock.

2. To guarantee proper operation.

A.C. CHARACTERISTICS ($T_A = 0^\circ\text{C}$ to $+70^\circ\text{C}$, $V_{CC} = 5\text{V} \pm 10\%$) (Continued)

Master Interface Timing Responses (Continued)

Symbol	Parameter	8 MHz		10 MHz		Units	Test Conditions
		Min	Max	Min	Max		
T_{AZRL}	Address Float to \overline{RD} Active	0		0		ns	
T_{CLRL}	\overline{RD} Active Delay	10	70	10	56	ns	
T_{CLRH}	\overline{RD} Inactive Delay	10	55	10	44	ns	
T_{RHAV}	\overline{RD} Inactive to Address Active	$T_{CLCL} - 40$		$T_{CLCL} - 40$		ns	
T_{CLHAV}	HLDA Valid Delay	5	50	5	40	ns	
T_{RLRH}	\overline{RD} Width	$2T_{CLCL} - 50$		$2T_{CLCL} - 46$		ns	
T_{WLWH}	\overline{WR} Width	$2T_{CLCL} - 40$		$2T_{CLCL} - 34$		ns	
T_{AVLL}	Address Valid to ALE Low	$T_{CLCH} - 25$		$T_{CLCH} - 19$		ns	
T_{CHSV}	Status Active Delay	10	55	10	45	ns	
T_{CLSH}	Status Inactive Delay	10	65	10	50	ns	
T_{CLTMV}	Timer Output Delay		60		48	ns	100 pF max @ 8 & 10 MHz
T_{CLRO}	Reset Delay		60		48	ns	
T_{CHQSV}	Queue Status Delay		35		28	ns	
T_{CHDX}	Status Hold Time	10		10		ns	
T_{AVCH}	Address Valid to Clock High	10		10		ns	
T_{CLLV}	\overline{LOCK} Valid/Invalid Delay	5	65	5	60	ns	

Chip-Select Timing Responses

T_{CLCSV}	Chip-Select Active Delay		66		45	ns	
T_{CXCSX}	Chip-Select Hold from Command Inactive	35		35		ns	
T_{CHCSX}	Chip-Select Inactive Delay	5	35	5	32	ns	

CLKIN Requirements

T_{CKIN}	CLKIN Period	62.5	250	50	250	ns	
T_{CKHL}	CLKIN Fall Time		10		10	ns	3.5 to 1.0V
T_{CKLH}	CLKIN Rise Time		10		10	ns	1.0 to 3.5V
T_{CLCK}	CLKIN Low Time	25		20		ns	1.5V
T_{CHCK}	CLKIN High Time	25		20		ns	1.5V

CLKOUT Timing (200 pF load)

T_{CICO}	CLKIN to CLKOUT Skew		50		25	ns	
T_{CLCL}	CLKOUT Period	125	500	100	500	ns	
T_{CLCH}	CLKOUT Low Time	$\frac{1}{2} T_{CLCL} - 7.5$		$\frac{1}{2} T_{CLCL} - 6.0$		ns	1.5V
T_{CHCL}	CLKOUT High Time	$\frac{1}{2} T_{CLCL} - 7.5$		$\frac{1}{2} T_{CLCL} - 6.0$		ns	1.5V
T_{CH1CH2}	CLKOUT Rise Time		15		12	ns	1.0 to 3.5V
T_{CL2CL1}	CLKOUT Fall Time		15		12	ns	3.5 to 1.0V

EXPLANATION OF THE AC SYMBOLS

Each timing symbol has from 5 to 7 characters. The first character is always a "T" (stands for time). The other characters, depending on their positions, stand for the name of a signal or the logical status of that signal. The following is a list of all the characters and what they stand for.

A: Address
 ARY: Asynchronous Ready Input
 C: Clock Output
 CK: Clock Input
 CS: Chip Select
 CT: Control ($\overline{DT}/\overline{R}$, \overline{DEN} , . . .)
 D: Data Input
 DE: \overline{DEN}
 H: Logic Level High

IN: Input (DRQ0, TIM0, . . .)
 L: Logic Level Low or ALE
 O: Output
 QS: Queue Status (QS1, QS2)
 R: \overline{RD} signal, RESET signal
 S: Status ($\overline{S0}$, $\overline{S1}$, $\overline{S2}$)
 SRY: Synchronous Ready Input
 V: Valid
 W: WR Signal
 X: No Longer a Valid Logic Level
 Z: Float

Examples:

T_{CLAV} — Time from Clock low to Address valid
 T_{CHLH} — Time from Clock high to ALE high
 T_{CLCSV} — Time from Clock low to Chip Select valid

WAVEFORMS

MAJOR CYCLE TIMING

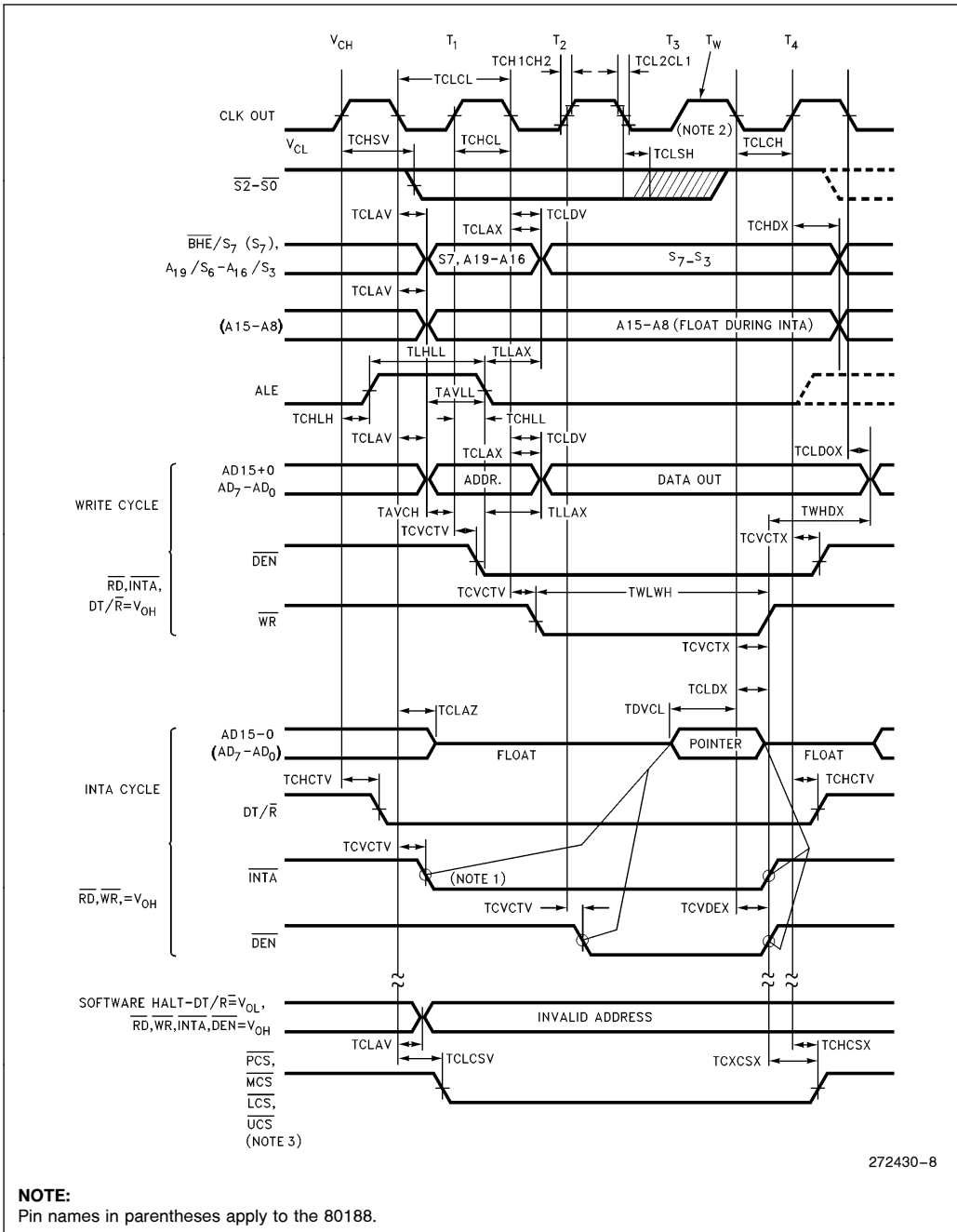

272430-8

WAVEFORMS (Continued)

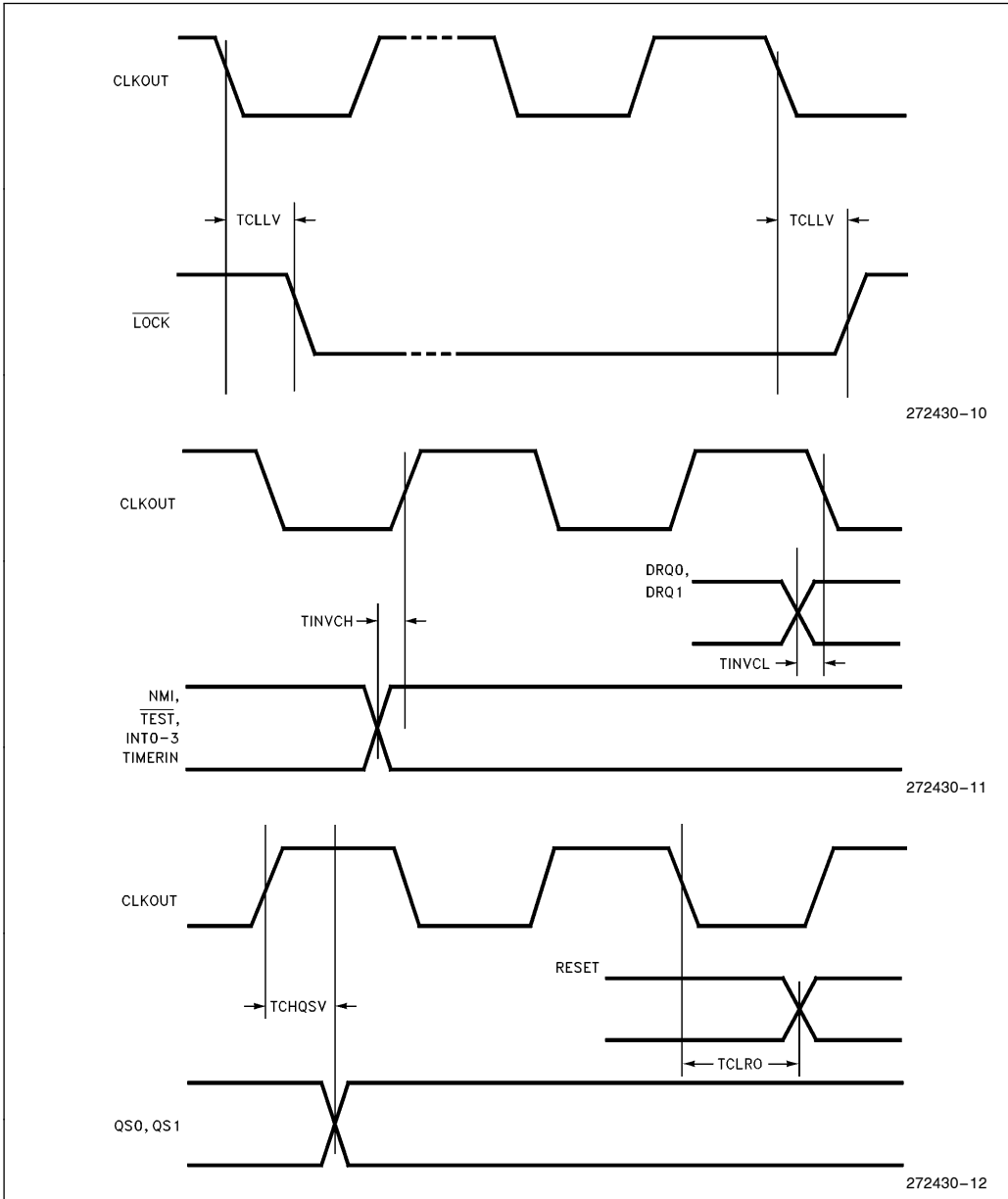

WAVEFORMS (Continued)

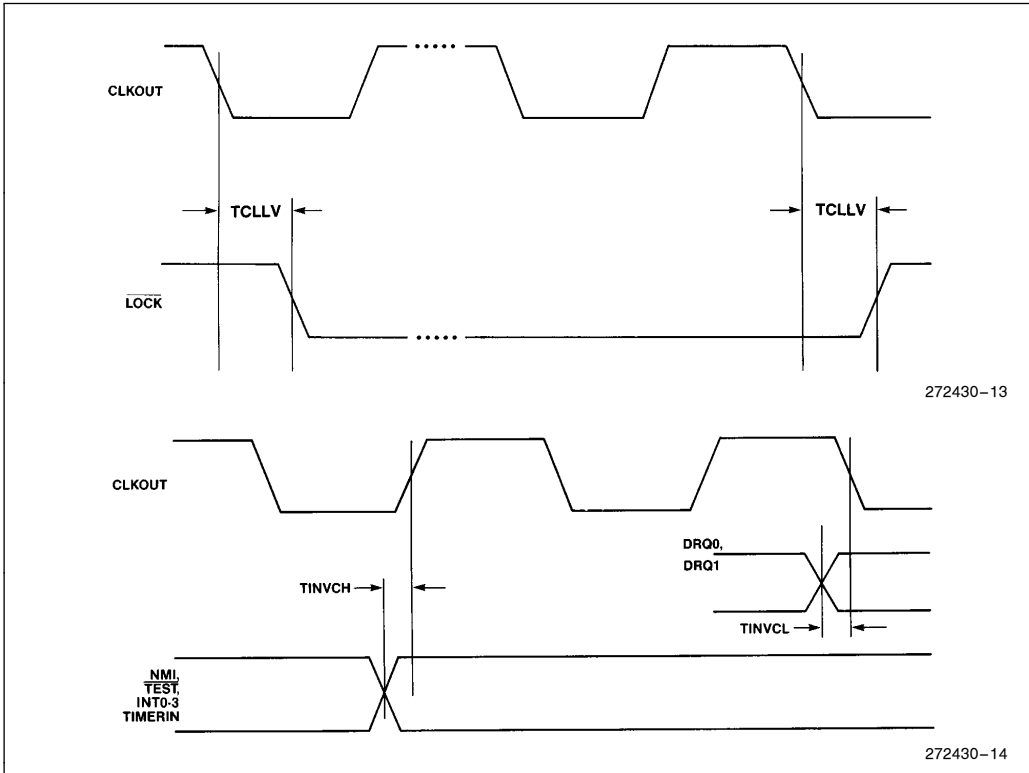

WAVEFORMS (Continued)

READY TIMING

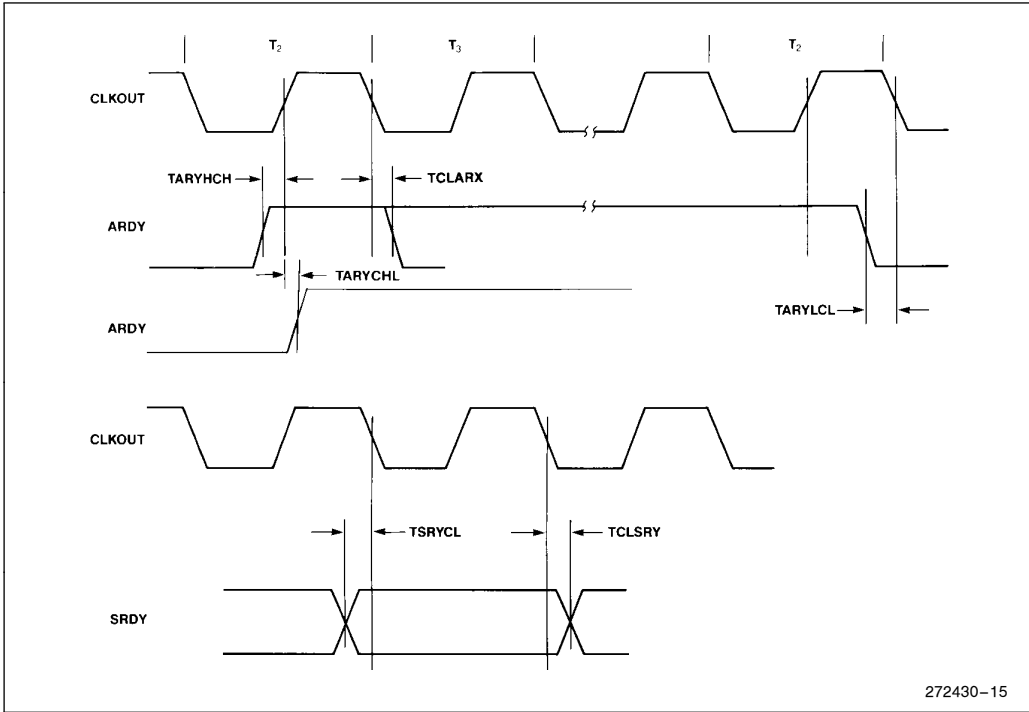

WAVEFORMS (Continued)

HOLD/HLDA TIMING (Entering Hold)

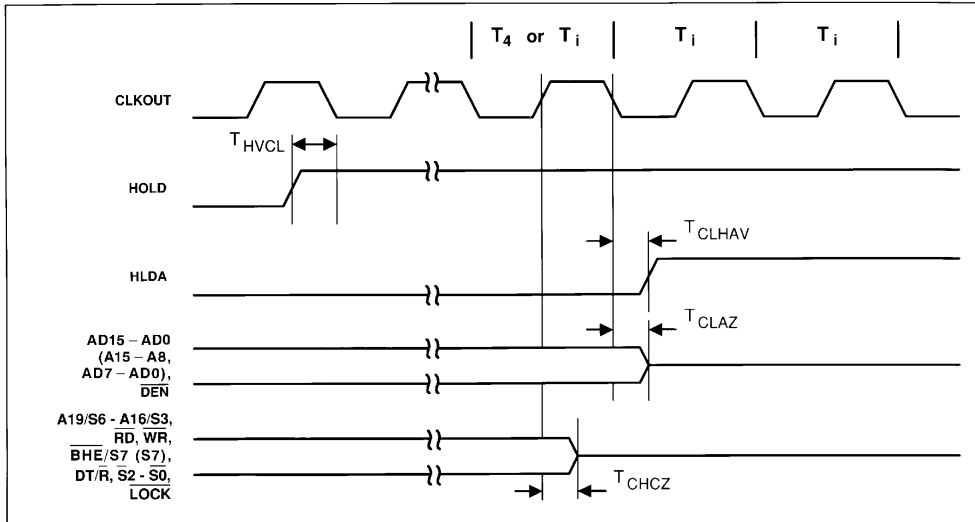

HOLD/HLDA TIMING (Leaving Hold)

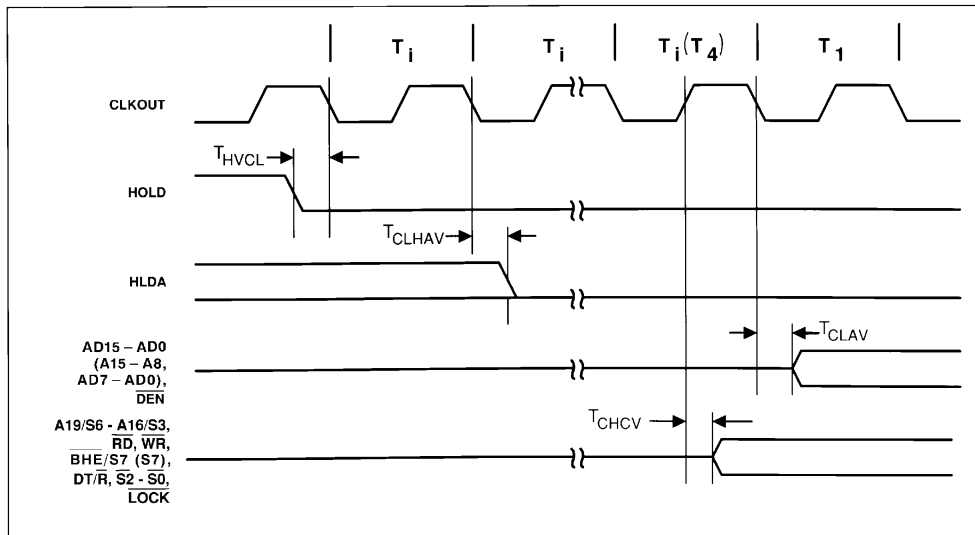

272430-16

NOTE:
Pin names in parentheses apply to the 80188.

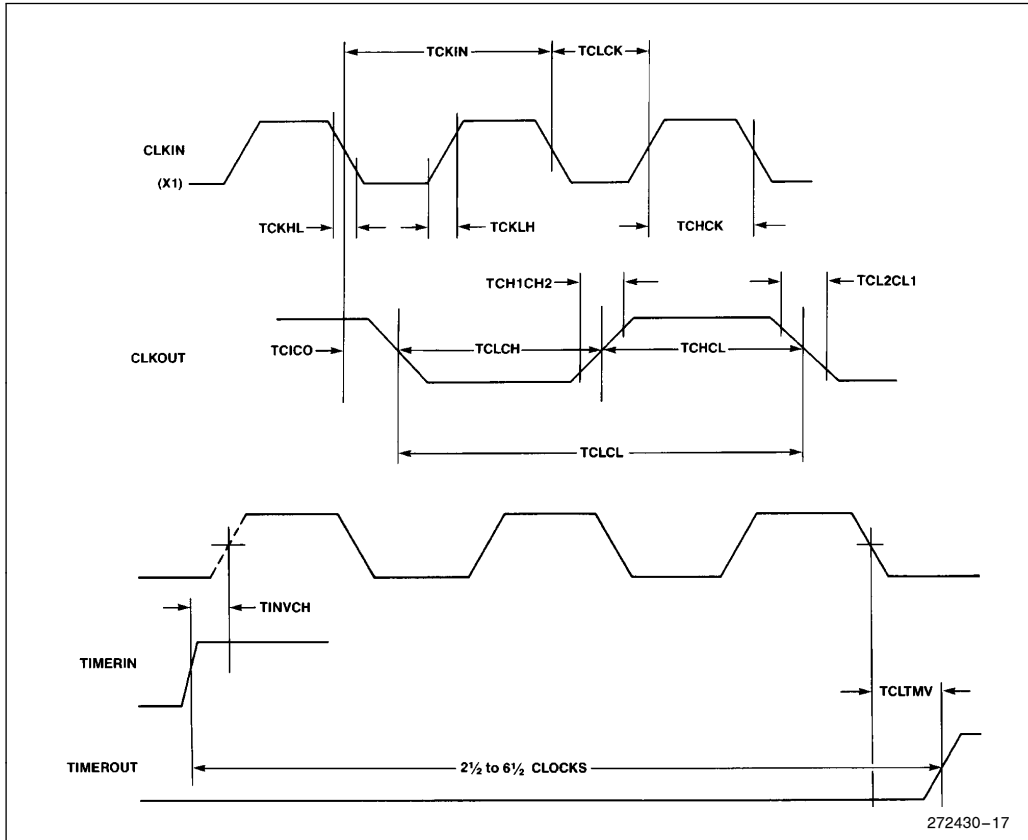
WAVEFORMS (Continued)

EXPRESS

The Intel EXPRESS system offers enhancements to the operational specifications of the microprocessor. EXPRESS products are designed to meet the needs of those applications whose operating requirements exceed commercial standards.

The EXPRESS program includes the commercial standard temperature range with burn-in and an extended temperature range without burn-in.

With the commercial standard temperature range operational characteristics are guaranteed over the temperature range of 0°C to +70°C. With the extended temperature range option, operational characteristics are guaranteed over the range of -40°C to +85°C.

The optional burn-in is dynamic, for a minimum time of 160 hours at +125°C with $V_{CC} = 5.5V \pm 0.25V$, following guidelines in MIL-STD-883, Method 1015.

Package types and EXPRESS versions are identified by a one- or two-letter prefix to the part number. The prefixes are listed in Table 2. All A.C. and D.C. specifications not mentioned in this section are the same for both commercial and EXPRESS parts.

Table 2. Prefix Identification

Prefix	Package Type	Temperature Range	Burn-In
A	PGA	Commercial	No
N	PLCC	Commercial	No
R	LCC	Commercial	No
TA	PGA	Extended	No
QA	PGA	Commercial	Yes
QR	LCC	Commercial	Yes

NOTE:

Not all package/temperature range/speed combinations are available.

EXECUTION TIMINGS

A determination of program execution timing must consider the bus cycles necessary to prefetch instructions as well as the number of execution unit cycles necessary to execute instructions. The following instruction timings represent the minimum execution time in clock cycles for each instruction. The timings given are based on the following assumptions:

- The opcode, along with any data or displacement required for execution of a particular instruction, has been prefetched and resides in the queue at the time it is needed.
- No wait states or bus HOLDS occur.
- All word-data is located on even-address boundaries.

All instructions which involve memory accesses can also require one or two additional clocks above the minimum timings shown due to the asynchronous handshake between the bus interface unit (BIU) and execution unit.

All jumps and calls include the time required to fetch the opcode of the next instruction at the destination address.

The 80186 has sufficient bus performance to ensure that an adequate number of prefetched bytes will reside in the queue (6 bytes) most of the time. Therefore, actual program execution time will not be substantially greater than that derived from adding the instruction timings shown.

The 80188 is noticeably limited in its performance relative to the execution unit. A sufficient number of prefetched bytes may not reside in the prefetch queue (4 bytes) much of the time. Therefore, actual program execution time may be substantially greater than that derived from adding the instruction timings shown.

INSTRUCTION SET SUMMARY

Function	Format	80186 Clock Cycles	80188 Clock Cycles	Comments
DATA TRANSFER				
MOV = Move:				
Register to Register/Memory	1 0 0 0 1 0 0 w mod reg r/m	2/12	2/12*	
Register/memory to register	1 0 0 0 1 0 1 w mod reg r/m	2/9	2/9*	
Immediate to register/memory	1 1 0 0 0 1 1 w mod 000 r/m data data if w = 1	12/13	12/13	8/16-bit
Immediate to register	1 0 1 1 w reg data data if w = 1	3/4	3/4	8/16-bit
Memory to accumulator	1 0 1 0 0 0 0 w addr-low addr-high	8	8*	
Accumulator to memory	1 0 1 0 0 0 1 w addr-low addr-high	9	9*	
Register/memory to segment register	1 0 0 0 1 1 1 0 mod 0 reg r/m	2/9	2/13	
Segment register to register/memory	1 0 0 0 1 1 0 0 mod 0 reg r/m	2/11	2/15	
PUSH = Push:				
Memory	1 1 1 1 1 1 1 1 mod 1 1 0 r/m	16	20	
Register	0 1 0 1 0 reg	10	14	
Segment register	0 0 0 reg 1 1 0	9	13	
Immediate	0 1 1 0 1 0 s 0 data data if s = 0	10	14	
PUSHA = Push All				
0 1 1 0 0 0 0 0		36	68	
POP = Pop:				
Memory	1 0 0 0 1 1 1 1 mod 0 0 0 r/m	20	24	
Register	0 1 0 1 1 reg	10	14	
Segment register	0 0 0 reg 1 1 1 (reg ≠ 01)	8	12	
POPA = Pop All				
0 1 1 0 0 0 0 1		51	83	
XCHG = Exchange:				
Register/memory with register	1 0 0 0 0 1 1 w mod reg r/m	4/17	4/17*	
Register with accumulator	1 0 0 1 0 reg	3	3	
IN = Input from:				
Fixed port	1 1 1 0 0 1 0 w port	10	10*	
Variable port	1 1 1 0 1 1 0 w	8	8*	
OUT = Output to:				
Fixed port	1 1 1 0 0 1 1 w port	9	9*	
Variable port	1 1 1 0 1 1 1 w	7	7*	
XLAT = Translate byte to AL	1 1 0 1 0 1 1 1	11	15	
LEA = Load EA to register	1 0 0 0 1 1 0 1 mod reg r/m	6	6	
LDS = Load pointer to DS	1 1 0 0 0 1 0 1 mod reg r/m (mod ≠ 11)	18	26	
LES = Load pointer to ES	1 1 0 0 0 1 0 0 mod reg r/m (mod ≠ 11)	18	26	
LAHF = Load AH with flags	1 0 0 1 1 1 1 1	2	2	
SAHF = Store AH into flags	1 0 0 1 1 1 1 0	3	3	
PUSHF = Push flags	1 0 0 1 1 1 0 0	9	13	
POPF = Pop flags	1 0 0 1 1 1 0 1	8	12	

Shaded areas indicate instructions not available in 8086, 8088 microsystems.

NOTE:

*Clock cycles shown for byte transfers, for word operations, add 4 clock cycles for each memory transfer.

INSTRUCTION SET SUMMARY (Continued)

Function	Format	80186 Clock Cycles	80188 Clock Cycles	Comments
DATA TRANSFER (Continued)				
SEGMENT = Segment Override:				
CS	00101110	2	2	
SS	00110110	2	2	
DS	00111110	2	2	
ES	00100110	2	2	
ARITHMETIC				
ADD = Add:				
Reg/memory with register to either	00000dw mod reg r/m	3/10	3/10*	
Immediate to register/memory	10000sw mod 000 r/m data data if sw=01	4/16	4/16*	
Immediate to accumulator	000010w data data if w=1	3/4	3/4	8/16-bit
ADC = Add with carry:				
Reg/memory with register to either	00010dw mod reg r/m	3/10	3/10*	
Immediate to register/memory	10000sw mod 010 r/m data data if sw=01	4/16	4/16*	
Immediate to accumulator	0001010w data data if w=1	3/4	3/4	8/16-bit
INC = Increment:				
Register/memory	1111111w mod 000 r/m	3/15	3/15*	
Register	01000 reg	3	3	
SUB = Subtract:				
Reg/memory and register to either	001010dw mod reg r/m	3/10	3/10*	
Immediate from register/memory	10000sw mod 101 r/m data data if sw=01	4/16	4/16*	
Immediate from accumulator	0010110w data data if w=1	3/4	3/4	8/16-bit
SBB = Subtract with borrow:				
Reg/memory and register to either	000110dw mod reg r/m	3/10	3/10*	
Immediate from register/memory	10000sw mod 011 r/m data data if sw=01	4/16	4/16*	
Immediate from accumulator	0001110w data data if w=1	3/4	3/4	8/16-bit
DEC = Decrement				
Register/memory	1111111w mod 001 r/m	3/15	3/15*	
Register	01001 reg	3	3	
CMP = Compare:				
Register/memory with register	0011101w mod reg r/m	3/10	3/10*	
Register with register/memory	0011100w mod reg r/m	3/10	3/10*	
Immediate with register/memory	10000sw mod 111 r/m data data if sw=01	3/10	3/10*	
Immediate with accumulator	0011110w data data if w=1	3/4	3/4	8/16-bit
NEG = Change sign register/memory	1111011w mod 011 r/m	3/10	3/10*	
AAA = ASCII adjust for add	00110111	8	8	
DAA = Decimal adjust for add	00100111	4	4	
AAS = ASCII adjust for subtract	00111111	7	7	
DAS = Decimal adjust for subtract	00101111	4	4	
MUL = Multiply (unsigned):				
Register-Byte	1111011w mod 100 r/m	26-28	26-28	
Register-Word		35-37	35-37	
Memory-Byte		32-34	32-34	
Memory-Word		41-43	41-43*	

Shaded areas indicate instructions not available in 8086, 8088 microsystems.

NOTE:

*Clock cycles shown for byte transfers, for word operations, add 4 clock cycles for each memory transfer.

INSTRUCTION SET SUMMARY (Continued)

Function	Format	80186 Clock Cycles	80188 Clock Cycles	Comments
ARITHMETIC (Continued)				
IMUL = Integer multiply (signed):	1 1 1 1 0 1 1 w mod 1 0 1 r/m			
Register-Byte		25–28	25–28	
Register-Word		34–37	34–37	
Memory-Byte		31–34	31–34	
Memory-Word		40–43	40–43*	
IMUL = Integer Immediate multiply (signed)	0 1 1 0 1 0 s 1 mod reg r/m data data if s = 0	22–25/ 29–32	22–25/ 29–32	
DIV = Divide (unsigned):	1 1 1 1 0 1 1 w mod 1 1 0 r/m			
Register-Byte		29	29	
Register-Word		38	38	
Memory-Byte		35	35	
Memory-Word		44	44*	
IDIV = Integer divide (signed):	1 1 1 1 0 1 1 w mod 1 1 1 r/m			
Register-Byte		44–52	44–52	
Register-Word		53–61	53–61	
Memory-Byte		50–58	50–58	
Memory-Word		59–67	59–67*	
AAM = ASCII adjust for multiply	1 1 0 1 0 1 0 0 0 0 0 0 1 0 1 0	19	19	
AAD = ASCII adjust for divide	1 1 0 1 0 1 0 1 0 0 0 0 1 0 1 0	15	15	
CBW = Convert byte to word	1 0 0 1 1 0 0 0	2	2	
CWD = Convert word to double word	1 0 0 1 1 0 0 1	4	4	
LOGIC				
Shift/Rotate Instructions:				
Register/Memory by 1	1 1 0 1 0 0 0 w mod TTT r/m	2/15	2/15	
Register/Memory by CL	1 1 0 1 0 0 1 w mod TTT r/m	5 + n/17 + n	5 + n/17 + n	
Register/Memory by Count	1 1 0 0 0 0 0 w mod TTT r/m count	5 + n/17 + n	5 + n/17 + n	
TTT Instruction				
0 0 0 ROL				
0 0 1 ROR				
0 1 0 RCL				
0 1 1 RCR				
1 0 0 SHL/SAL				
1 0 1 SHR				
1 1 1 SAR				
AND = And:				
Reg/memory and register to either	0 0 1 0 0 0 d w mod reg r/m	3/10	3/10*	
Immediate to register/memory	1 0 0 0 0 0 0 w mod 1 0 0 r/m data data if w = 1	4/16	4/16*	
Immediate to accumulator	0 0 1 0 0 1 0 w data data if w = 1	3/4	3/4	8/16-bit
TEST = And function to flags, no result:				
Register/memory and register	1 0 0 0 0 1 0 w mod reg r/m	3/10	3/10*	
Immediate data and register/memory	1 1 1 1 0 1 1 w mod 0 0 0 r/m data data if w = 1	4/10	4/10*	
Immediate data and accumulator	1 0 1 0 1 0 0 w data data if w = 1	3/4	3/4	8/16-bit
OR = Or:				
Reg/memory and register to either	0 0 0 0 1 0 d w mod reg r/m	3/10	3/10*	
Immediate to register/memory	1 0 0 0 0 0 0 w mod 0 0 1 r/m data data if w = 1	4/16	4/16*	
Immediate to accumulator	0 0 0 0 1 1 0 w data data if w = 1	3/4	3/4	8/16-bit

Shaded areas indicate instructions not available in 8086, 8088 microsystems.

NOTE:

*Clock cycles shown for byte transfers, for word operations, add 4 clock cycles for each memory transfer.

INSTRUCTION SET SUMMARY (Continued)

Function	Format	80186 Clock Cycles	80188 Clock Cycles	Comments
LOGIC (Continued)				
XOR = Exclusive or:				
Reg/memory and register to either	0 0 1 1 0 0 d w mod reg r/m	3/10	3/10*	8/16-bit
Immediate to register/memory	1 0 0 0 0 0 w mod 1 1 0 r/m data data if w = 1	4/16	4/16*	
Immediate to accumulator	0 0 1 1 0 1 0 w data data if w = 1	3/4	3/4	
NOT = Invert register/memory	1 1 1 1 0 1 1 w mod 0 1 0 r/m	3/10	3/10*	
STRING MANIPULATION				
MOVS = Move byte/word	1 0 1 0 0 1 0 w	14	14*	
CMPS = Compare byte/word	1 0 1 0 0 1 1 w	22	22*	
SCAS = Scan byte/word	1 0 1 0 1 1 1 w	15	15*	
LODS = Load byte/wd to AL/AX	1 0 1 0 1 1 0 w	12	12*	
STOS = Store byte/wd from AL/AX	1 0 1 0 1 0 1 w	10	10*	
INS = Input byte/wd from DX port	0 1 1 0 1 1 0 w	14	14	
OUTS = Output byte/wd to DX port	0 1 1 0 1 1 1 w	14	14	
Repeated by count in CX (REP/REPE/REPZ/REPNE/REPNZ)				
MOVS = Move string	1 1 1 1 0 0 1 0 1 0 1 0 0 1 0 w	8 + 8n	8 + 8n*	
CMPS = Compare string	1 1 1 1 0 0 1 z 1 0 1 0 0 1 1 w	5 + 22n	5 + 22n*	
SCAS = Scan string	1 1 1 1 0 0 1 z 1 0 1 0 1 1 1 w	5 + 15n	5 + 15n*	
LODS = Load string	1 1 1 1 0 0 1 0 1 0 1 0 1 1 0 w	6 + 11n	6 + 11n*	
STOS = Store string	1 1 1 1 0 0 1 0 1 0 1 0 1 0 1 w	6 + 9n	6 + 9n*	
INS = Input string	1 1 1 1 0 0 1 0 0 1 1 0 1 1 0 w	8 + 8n	8 + 8n*	
OUTS = Output string	1 1 1 1 0 0 1 0 0 1 1 0 1 1 1 w	8 + 8n	8 + 8n*	
CONTROL TRANSFER				
CALL = Call:				
Direct within segment	1 1 1 0 1 0 0 0 disp-low disp-high	15	19	
Register/memory indirect within segment	1 1 1 1 1 1 1 1 mod 0 1 0 r/m	13/19	17/27	
Direct intersegment	1 0 0 1 1 0 1 0 segment offset segment selector	23	31	
Indirect intersegment	1 1 1 1 1 1 1 1 mod 0 1 1 r/m (mod ≠ 11)	38	54	
JMP = Unconditional jump:				
Short/long	1 1 1 0 1 0 1 1 disp-low	14	14	
Direct within segment	1 1 1 0 1 0 0 1 disp-low disp-high	14	14	
Register/memory indirect within segment	1 1 1 1 1 1 1 1 mod 1 0 0 r/m	11/17	11/21	
Direct intersegment	1 1 1 0 1 0 1 0 segment offset segment selector	14	14	
Indirect intersegment	1 1 1 1 1 1 1 1 mod 1 0 1 r/m (mod ≠ 11)	26	34	

Shaded areas indicate instructions not available in 8086, 8088 microsystems.

NOTE:

*Clock cycles shown for byte transfers, for word operations, add 4 clock cycles for each memory transfer.

INSTRUCTION SET SUMMARY (Continued)

Function	Format	80186 Clock Cycles	80188 Clock Cycles	Comments
CONTROL TRANSFER (Continued)				
RET = Return from CALL:				
Within segment	11000011	16	20	
Within seg adding immed to SP	11000010 data-low data-high	18	22	
Intersegment	11001011	22	30	
Intersegment adding immediate to SP	11001010 data-low data-high	25	33	
JE/JZ = Jump on equal/zero	01110100 disp	4/13	4/13	JMP not taken/JMP taken
JL/JNGE = Jump on less/not greater or equal	01111100 disp	4/13	4/13	
JLE/JNG = Jump on less or equal/not greater	01111110 disp	4/13	4/13	
JB/JNAE = Jump on below/not above or equal	01110010 disp	4/13	4/13	
JBE/JNA = Jump on below or equal/not above	01110110 disp	4/13	4/13	
JP/JPE = Jump on parity/parity even	01111010 disp	4/13	4/13	
JO = Jump on overflow	01110000 disp	4/13	4/13	
JS = Jump on sign	01111000 disp	4/13	4/13	
JNE/JNZ = Jump on not equal/not zero	01110101 disp	4/13	4/13	
JNL/JGE = Jump on not less/greater or equal	01111101 disp	4/13	4/13	
JNLE/JG = Jump on not less or equal/greater	01111111 disp	4/13	4/13	
JNB/JAE = Jump on not below/above or equal	01110011 disp	4/13	4/13	
JNBE/JA = Jump on not below or equal/above	01110111 disp	4/13	4/13	
JNP/JPO = Jump on not par/par odd	01111011 disp	4/13	4/13	
JNO = Jump on not overflow	01110001 disp	4/13	4/13	
JNS = Jump on not sign	01111001 disp	4/13	4/13	
JCXZ = Jump on CX zero	11100011 disp	5/15	5/15	LOOP not taken/LOOP taken
LOOP = Loop CX times	11100010 disp	6/16	6/16	
LOOPZ/LOOPE = Loop while zero/equal	11100001 disp	6/16	6/16	
LOOPNZ/LOOPNE = Loop while not zero/equal	11100000 disp	6/16	6/16	
ENTER = Enter Procedure	11001000 data-low data-high L	15	19	
L = 0		25	29	
L = 1		22 + 16(n - 1)	26 + 20(n - 1)	
LEAVE = Leave Procedure	11001001	8	8	
INT = Interrupt:				
Type specified	11001101 type	47	47	if INT. taken/ if INT. not taken
Type 3	11001100	45	45	
INTO = Interrupt on overflow	11001110	48/4	48/4	
IRET = Interrupt return	11001111	28	28	
BOUND = Detect value out of range	01100010 mod reg r/m	33-35	33-35	

Shaded areas indicate instructions not available in 8086, 8088 microsystems.

NOTE:

*Clock cycles shown for byte transfers, for word operations, add 4 clock cycles for each memory transfer.



INSTRUCTION SET SUMMARY (Continued)

Function	Format	80186 Clock Cycles	80188 Clock Cycles	Comments
PROCESSOR CONTROL				
CLC = Clear carry	11111000	2	2	
CMC = Complement carry	11110101	2	2	
STC = Set carry	11111001	2	2	
CLD = Clear direction	11111100	2	2	
STD = Set direction	11111101	2	2	
CLI = Clear interrupt	11111010	2	2	
STI = Set interrupt	11111011	2	2	
HLT = Halt	11110100	2	2	
WAIT = Wait	10011011	6	6	if TEST = 0
LOCK = Bus lock prefix	11110000	2	3	
ESC = Processor Extension Escape	11011TTT mod LLL r/m	6	6	
	(TTT LLL are opcode to processor extension)			
NOP = No Operation	10010000	3	3	

Shaded areas indicate instructions not available in 8086, 8088 microsystems.

NOTE:

*Clock cycles shown for byte transfers, for word operations, add 4 clock cycles for each memory transfer.

FOOTNOTES

The Effective Address (EA) of the memory operand is computed according to the mod and r/m fields:

- if mod = 11 then r/m is treated as REG field
- if mod = 00 then DISP = 0*, disp-low and disp-high are absent
- if mod = 01 then DISP = disp-low sign-extended to 16-bits, disp-high is absent
- if mod = 10 then DISP = disp-high: disp-low
- if r/m = 000 then EA = (BX) + (SI) + DISP
- if r/m = 001 then EA = (BX) + (DI) + DISP
- if r/m = 010 then EA = (BP) + (SI) + DISP
- if r/m = 011 then EA = (BP) + (DI) + DISP
- if r/m = 100 then EA = (SI) + DISP
- if r/m = 101 then EA = (DI) + DISP
- if r/m = 110 then EA = (BP) + DISP*
- if r/m = 111 then EA = (BX) + DISP

DISP follows 2nd byte of instruction (before data if required)

*except if mod = 00 and r/m = 110 then EA = disp-high: disp-low.

EA calculation time is 4 clock cycles for all modes, and is included in the execution times given whenever appropriate.

Segment Override Prefix

0	0	1	reg	1	1	0
---	---	---	-----	---	---	---

reg is assigned according to the following:

reg	Segment Register
00	ES
01	CS
10	SS
11	DS

REG is assigned according to the following table:

16-Bit (w = 1)	8-Bit (w = 0)
000 AX	000 AL
001 CX	001 CL
010 DX	010 DL
011 BX	011 BL
100 SP	100 AH
101 BP	101 CH
110 SI	110 DH
111 DI	111 BH

The physical addresses of all operands addressed by the BP register are computed using the SS segment register. The physical addresses of the destination operands of the string primitive operations (those addressed by the DI register) are computed using the ES segment, which may not be overridden.



80186/80188

REVISION HISTORY

This data sheet replaces the following data sheets:

210706-011 80188

210451-011 80186

