

Low Voltage/Low Power CMOS 16-bit Microcontrollers

TMP93PW20AF

1. Outline and Device Characteristics

The TMP93PW20A is OTP type MCU which includes 128 Kbyte One-time PROM. Using the adapter-socket, you can write and verify the data for the TMP93CS20 by general EPROM programmer.

The TMP93PW20A has the same pin-assignment as the TMP93CS20 (Mask ROM type).

Writing the program to Built-in PROM, the TMP93PW20A operates as the same way as the TMP93CS20.

There are differences in the memory mapping area and the memory capacity of the internal PROM and RAM between the TMP93PW20A and the TMP93CS20. The internal PROM of the TMP93PW20A is 128 Kbytes, and the internal RAM is 4 Kbytes. The internal ROM of the TMP93CS20 is 64 Kbytes, and the internal RAM is 2 Kbytes. Memory maps are described as follows.

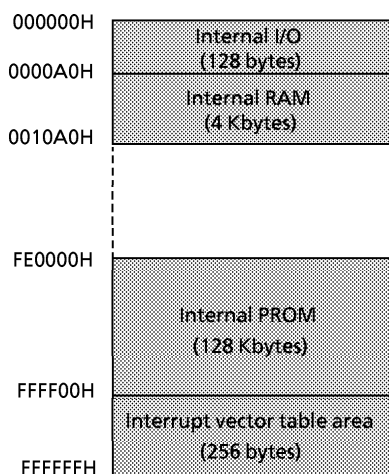

Memory map of TMP93PW20A

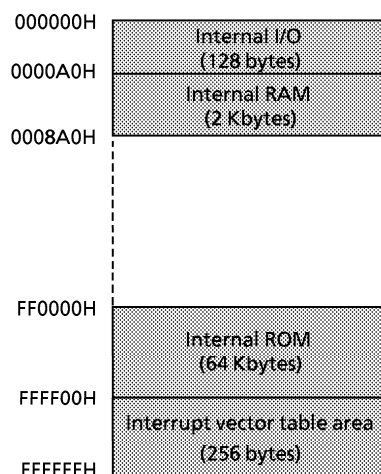

Memory map of TMP93CS20

Product No.	ROM	RAM	Package	Adapter Socket
TMP93PW20AF	OTP 128 Kbytes	4 Kbytes	P-LQFP144-1616-0.40	BM11141

000707EBP1

- For a discussion of how the reliability of microcontrollers can be predicted, please refer to Section 1.3 of the chapter entitled Quality and Reliability Assurance / Handling Precautions.
- TOSHIBA is continually working to improve the quality and reliability of its products. Nevertheless, semiconductor devices in general can malfunction or fail due to their inherent electrical sensitivity and vulnerability to physical stress. It is the responsibility of the buyer, when utilizing TOSHIBA products, to comply with the standards of safety in making a safe design for the entire system, and to avoid situations in which a malfunction or failure of such TOSHIBA products could cause loss of human life, bodily injury or damage to property. In developing your designs, please ensure that TOSHIBA products are used within specified operating ranges as set forth in the most recent TOSHIBA products specifications. Also, please keep in mind the precautions and conditions set forth in the "Handling Guide for Semiconductor Devices," or "TOSHIBA Semiconductor Reliability Handbook" etc..
- The TOSHIBA products listed in this document are intended for usage in general electronics applications (computer, personal equipment, office equipment, measuring equipment, industrial robotics, domestic appliances, etc.). These TOSHIBA products are neither intended nor warranted for usage in equipment that requires extraordinarily high quality and/or reliability or a malfunction or failure of which may cause loss of human life or bodily injury ("Unintended Usage"). Unintended Usage include atomic energy control instruments, airplane or spaceship instruments, transportation instruments, traffic signal instruments, combustion control instruments, medical instruments, all types of safety devices, etc.. Unintended Usage of TOSHIBA products listed in this document shall be made at the customer's own risk.
- The products described in this document are subject to the foreign exchange and foreign trade laws.
- The information contained herein is presented only as a guide for the applications of our products. No responsibility is assumed by TOSHIBA CORPORATION for any infringements of intellectual property or other rights of the third parties which may result from its use. No license is granted by implication or otherwise under any intellectual property or other rights of TOSHIBA CORPORATION or others.
- The information contained herein is subject to change without notice.



Purchase of TOSHIBA I²C components conveys a license under the Philips I²C Patent Rights to use these components in an I²C system, provided that the system conforms to the I²C Standard Specification as defined by Philips.

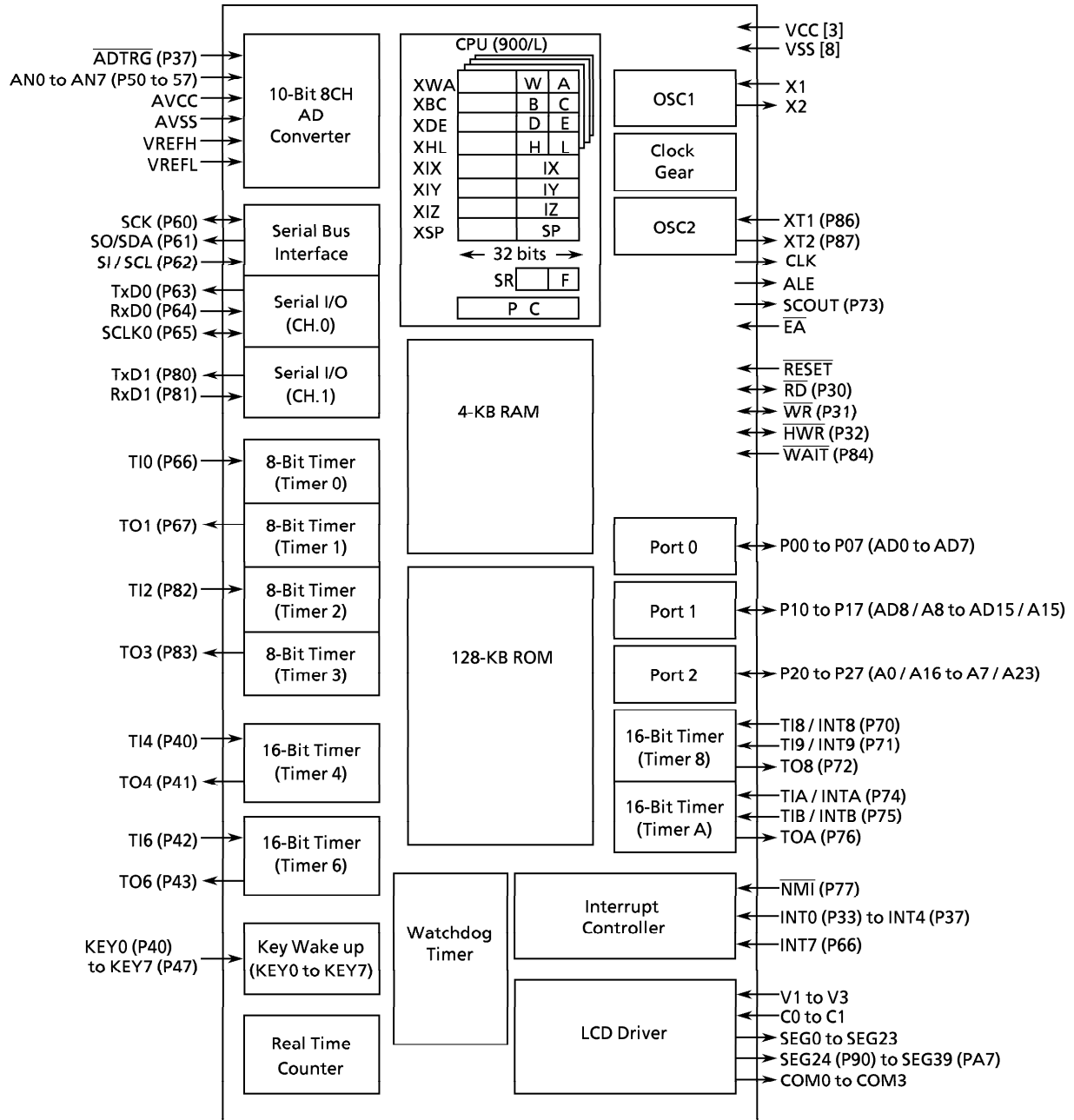

Note: The item in parentheses () are the initial setting after reset.

Figure 1 TMP93PW20A Block Diagram

2. Pin Assignment and Functions

The assignment of input/output pins for the TMP93PW20A their names and outline functions are described below.

2.1 Pin Assignment

Figure 2.1.1 shows pin assignment of the TMP93PW20A.

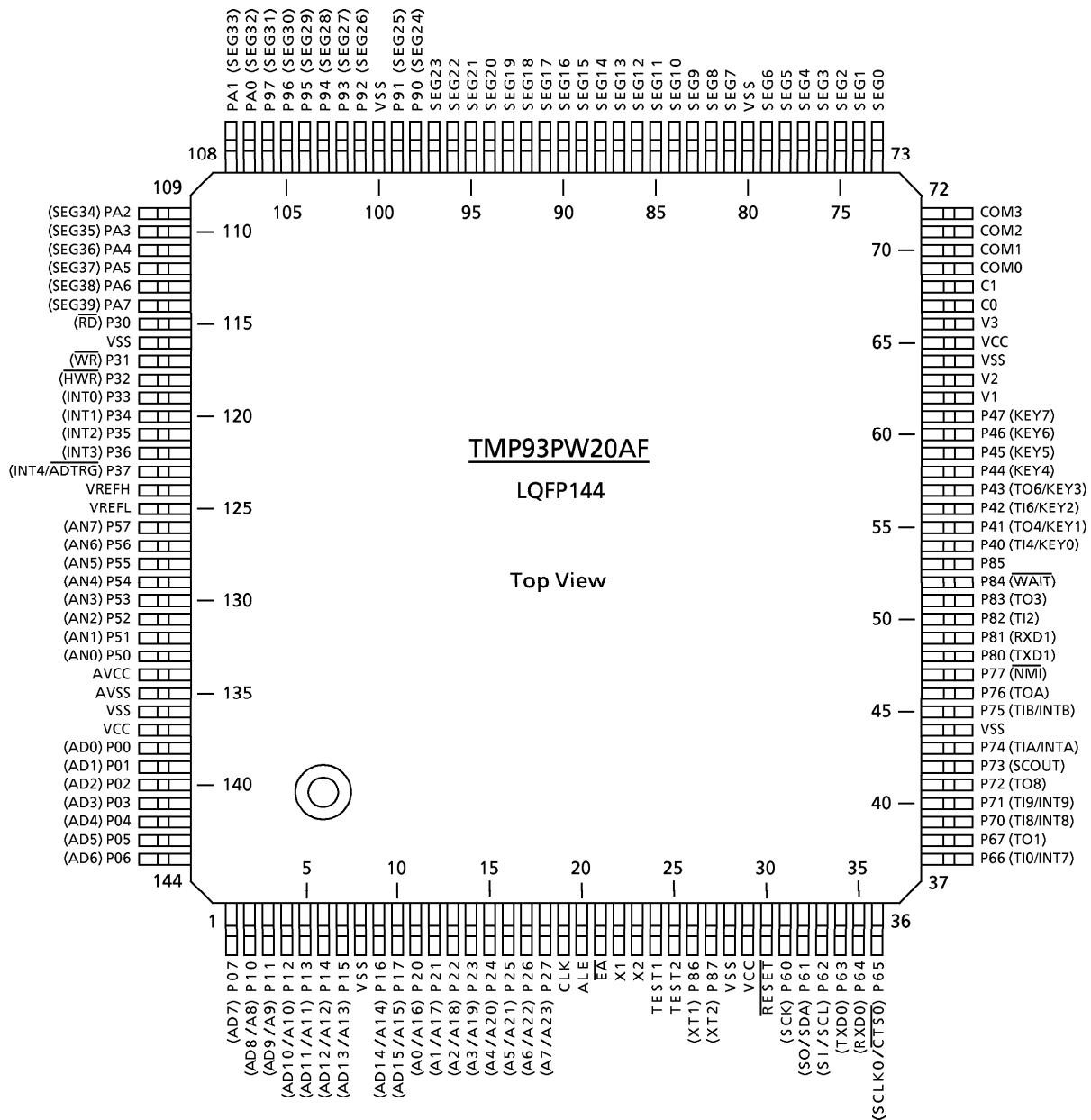

Figure 2.1.1 Pin Assignment (144-pin LQFP)

2.2 Pin Names and Functions

The TMP93PW20A has MCU mode and PROM mode.

- (1) Pin function of TMP93PW20A in MCU mode.

Table 2.2.1 Name and Function in MCU Mode (1/4)

Pin Name	Number of Pins	I/O	Functions
P00 to P07 AD0 to AD7	8	I/O I/O	Port 0: I/O port that allows I/O to be selected at the bit level Address and data (lower): Bits 0 to 7 for address and data bus
P10 to P17 AD8 to AD15 A8 to A15	8	I/O I/O Output	Port 1: I/O port that allows I/O to be selected at the bit level Address and data (upper): Bits 8 to 15 for address and data bus Address: Bits 8 to 15 for address bus
P20 to P27 A0 to A7 A16 to A23	8	I/O Output Output	Port 2: I/O port that allows I/O to be selected at the bit level (with pull-up resistor) Address: Bits 0 to 7 for address bus Address: Bits 16 to 23 for address bus
P30 RD	1	Output Output	Port 30: Output port Read: Strobe signal for reading external memory (Read when reading internal memory at $P3<P30> = 0$, $P3FC<P30F> = 1$)
P31 WR	1	Output Output	Port 31: Output port Write: Strobe signal for writing data on pins AD0 to 7
P32 HWR	1	I/O Output	Port 32: I/O port (with pull-up resistor) High write: Strobe signal for writing data on pins AD8 to 15
P33 INT0	1	I/O Input	Port 33: I/O port (with pull-up resistor) Interrupt request pin 0: Interrupt request pin with programmable level/rising/falling edge
P34 INT1	1	I/O Input	Port 34: I/O port (with pull-up resistor) Interrupt request pin 1: Interrupt request pin with programmable rising/falling edge
P35 INT2	1	I/O Input	Port 35: I/O port (with pull-up resistor) Interrupt request pin 2: Interrupt request pin with programmable rising/falling edge
P36 INT3	1	I/O Input	Port 36: I/O port (with pull-up resistor) Interrupt request pin 3: Interrupt request pin with programmable rising/falling edge
P37 INT4 ADTRG	1	I/O Input	Port 37: I/O port (with pull-up resistor) Interrupt request pin 4: Interrupt request pin with programmable rising/falling edge ADTRG Input AD external trigger pin: External trigger pin to start AD conversion
P40 TI4 KEY0	1	I/O Input Input	Port 40: I/O port (with pull-up resistor) Timer input 4: 16-bit timer 4 input Key input 0: Key-on wake-up pin 0

Table 2.2.1 Name and Function in MCU Mode (2/4)

Pin Name	Number of Pins	I/O	Functions
P41 TO4 KEY1	1	I/O Output Input	Port 41: I/O port (with pull-up resistor) Timer output 4: 16-bit timer 4 output Key input 1: Key-on wake-up pin 1
P42 TI6 KEY2	1	I/O Input Input	Port 42: I/O port (with pull-up resistor) Timer input 6: 16-bit timer 6 input Key input 2: Key-on wake-up pin 2
P43 TO6 KEY3	1	I/O Output Input	Port 43: I/O port (with pull-up resistor) Timer output 6: 16-bit timer 6 output Key input 3: Key-on wake-up pin 3
P44 to 47 KEY4 to KEY7	4	I/O Input	Port 44 to 47: I/O port (with pull-up resistor) Key input 4 to 7: Key-on wake-up pin 4 to 7
P50 to P57 AN0 to AN7	8	Input Input	Port 50 to 57: Pin used to input port Analog input 0 to 7
P60 SCK	1	I/O I/O	Port 60: I/O port Clock I/O pin in SIO mode of the serial bus interface
P61 SO SDA	1	I/O Output I/O	Port 61: I/O port (with programmable open-drain) Data send channel in SIO mode of the serial bus interface Data I/O pin in I ² C bus mode of the serial bus interface
P62 SI SCL	1	I/O Input I/O	Port 62: I/O port (with programmable open-drain) Data receive channel in SIO mode of the serial bus interface Clock I/O pin in I ² C bus mode of the serial bus interface
P63 TXD0	1	I/O Output	Port 63: I/O port (with programmable open-drain) Serial send data 0
P64 RXD0	1	I/O Input	Port 64: I/O port Serial receive data 0
P65 SCLK0 CTS0	1	I/O I/O Input	Port 65: I/O port Serial clock I/O 0 Serial data send enable 0 (Clear To Send)
P66 TI0 INT7	1	I/O Input Input	Port 66: I/O port Timer input 0: 8-bit timer 0 input Interrupt request pin 7: Interrupt request pin with programmable rising/falling edge
P67 TO1	1	I/O Output	Port 67: I/O port Timer output1: 8-bit timer 0 or timer 1 output
P70 TI8 INT8	1	I/O Input Input	Port 70: I/O port (with pull-up resistor) Timer input 8: 16-bit timer 8 input Interrupt request pin 8: Interrupt request pin with programmable rising/falling edge
P71 TI9 INT9	1	I/O Input Input	Port 71: I/O port (with pull-up resistor) Timer input 9: 16-bit timer 8 input Interrupt request pin 9: Interrupt request pin with rising edge

Table 2.2.1 Name and Function in MCU Mode (3/4)

Pin Name	Number of Pins	I/O	Functions
P72 TO8	1	I/O Output	Port 72: I/O port (with pull-up resistor) Timer output 8: 16-bit timer 8 output
P73 SCOUT	1	I/O Output	Port 73: I/O port (with pull-up resistor) System clock output: System clock or double system clock output to be synchronized with the external circuit
P74 TIA INTA	1	I/O Input Input	Port 74: I/O port (with pull-up resistor) Timer input A: 16-bit timer A input Interrupt request pin A: Interrupt request pin with programmable rising / falling edge
P75 TIB INTB	1	I/O Input Input	Port 75: I/O port (with pull-up resistor) Timer input B: 16-bit timer B input Interrupt request pin B: Interrupt request pin with rising edge
P76 TOA	1	I/O Output	Port 76: I/O port (with pull-up resistor) Timer output A: 16-bit timer A output
P77 NMI	1	I/O Input	Port 77: I/O port (with pull-up resistor) Non-maskable Interrupt request pin: Interrupt request pin with programmable falling edge or both edges.
P80 TXD1	1	I/O Output	Port 80: I/O port (with programmable open-drain) Serial send data 1
P81 RXD1	1	I/O Input	Port 81: I/O port (with programmable open-drain) Serial receive data 1
P82 TI2	1	I/O Input	Port 82: I/O port (with programmable open-drain) Timer input 2: 8-bit timer 2 input pin
P83 TO3	1	I/O Output	Port 83: I/O port (with programmable open-drain) Timer output 3: 8-bit timer 2, 3 output pin
P84 WAIT	1	I/O Input	Port 84: I/O port (with programmable open-drain) Wait: Pin used to request CPU bus wait
P85	1	I/O	Port 85: I/O port (with programmable open-drain)
P86 XT1	1	I/O Input	Port 86: I/O port (open-drain) Low Frequency Oscillator connecting pin
P87 XT2	1	I/O Output	Port 87: I/O port (open-drain) Low Frequency Oscillator connecting pin
P90 to P97 SEG24 to 31	8	Output Output	Port 90 to 97: Output port (open-drain) Segment data output pin
PA0 to PA7 SEG32 to 39	8	Output Output	Port A0 to A7: Output port, Large current port (open-drain) LCD segment output pin
SEG0 to 23	24	Output	LCD segment output
COM0 to 3	4	Output	LCD common output

Table 2.2.1 Pin Names and Function (4/4)

Pin Name	Number of Pins	I/O	Functions
AVCC	1	Power supply	Power supply pin for AD converter
AVSS	1	Power supply	GND pin for AD converter (0V)
VREFH	1	Input	Pin for reference voltage input to AD converter (H)
VREFL	1	Input	Pin for reference voltage input to AD converter (L)
X1	1	Input	Oscillator connecting pin
X2	1	Output	Oscillator connecting pin
RESET	1	Input	Reset: Initializes LSI
ALE	1	Output	Address Latch Enable Can be disabled for reducing noise.
CLK	1	Output	Clock output: Outputs "External input clock $\times 1 \div 4$ " Clock. Pulled-up during reset. Can be disabled for reducing noise.
EA	1	Input	The VCC pin should be connected.
VCC	3	Power supply	Power supply pin (All Vcc pins should be connected with the power supply pin.)
VSS	8	Power supply	GND pin (0V) (All Vss pins should be connected with GND (0V).)
TEST1 TEST2	2	Output Input	TEST1 should be connected with TEST2 pin.
C0, C1, V1 to V3	5	LCD pin	LCD drive boosting pin. A condenser should be connected between C0 and C1, V1, V2, V3 and GND.

Note: All pins that have built-in pull-up resistors can be disconnected from the built-in pull-up resistor by software.

(2) Pin function of the TMP93PW20A in PROM mode

Pin names and functions are shown in table 2.2.2.

Table 2.2.2 Pin Names and Function Is PROM Mode

Pin Function	Number of Pins	Input / Output	Function	Pin Name (MCU mode)
A7 to A0	8	Input	Memory address of program	P27 to P20
A15 to A8	8	Input		P17 to P10
A16	1	Input		P67
D7 to D0	8	I/O	Memory data of program	P07 to P00
\overline{CE}	1	Input	Chip enable	P32
\overline{OE}	1	Input	Output control	P30
\overline{PGM}	1	Input	Program control	P31
VPP	1	Power supply	12.75V/5V (Power supply of program)	\overline{EA}
VCC	4	Power supply	6.25V/5V	VCC, AVCC
VSS	9	Power supply	0V	VSS, AVSS
Pin function	Number of pins	Input/Output	Pin state	
P60	1	Input	Fix to low level (security pin)	
RESET	1	Input	Fix to low level (PROM mode)	
CLK	1	Input		
ALE	1	Output	Open	
X1	1	Input	Self oscillation with resonator	
X2	1	Output		
P66 to P61	6	Input	Fix to high level	
TEST1, TEST2	2	Input/Output	Short	
P37 to P33 P47 to P40 P57 to P50 P77 to P70 P87 to P80 P97 to P90 PA7 to PA0 SEG23 to 0 VREFH VREFL C0, C1 COM3 to 0 V3 to 1	88	I/O	Open	

3. Operation

This section describes the functions and basic operational blocks of the TMP93PW20A.

The TMP93PW20A has PROM in place of the mask ROM which is included in the TMP93CS20. The other configuration and functions are the same as the TMP93CS20. Regarding the function of the TMP93PW20A, which is not described herein, see the TMP93CS20.

The TMP93PW20A has two operational modes: MCU mode and PROM mode.

3.1 MCU mode

(1) Mode-setting and function

The MCU mode is set by releasing the CLK pin (Pin open). In the MCU mode, the operation is the same as TMP93CS20.

(2) Memory map

The memory map of TMP93PW20A differs from that of TMP93CS20. The memory map in MCU mode is shown in figure 3.1.1, and the memory map in PROM mode is shown in figure 3.1.2.

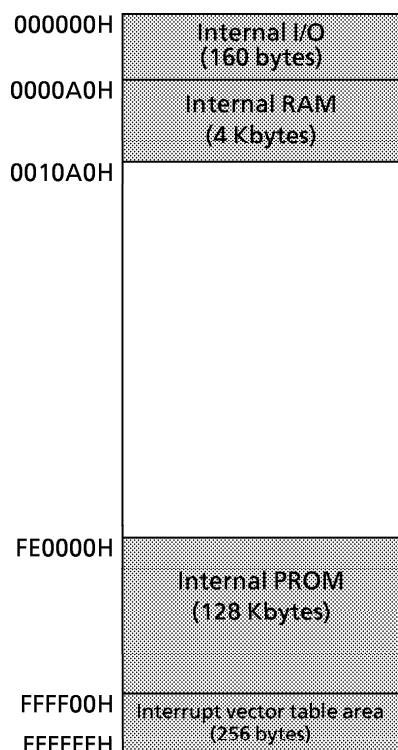

Figure 3.1.1 Memory Map in MCU Mode

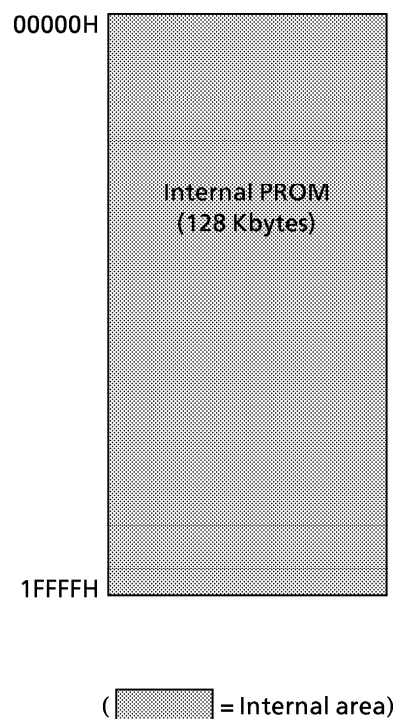

Figure 3.1.2 Memory Map in PROM Mode

4. Electrical Characteristics

4.1 Absolute Maximum Ratings
(TMP93PW20AF)

“X” used in an expression shows a frequency for the clock f_{PPH} selected by SYSCR1<SYSCK>. The value of X changes according to whether a clock gear or a low speed oscillator is selected. An example value is calculated for f_c , with gear = $f_c/1$ (SYSCR1<SYSCK, GEAR 2 to 0> = 0000).

Parameter	Symbol	Rating	Unit
Power Supply Voltage	V _{CC}	- 0.5 to 6.5	V
Input Voltage	V _{IN}	except \overline{EA} pin	- 0.5 to V _{CC} + 0.5
		\overline{EA} pin	- 0.5 to 14.0
Output Current (per one pin), Large current port	I _{OL1}	20	mA
Output Current (per one pin)	I _{OL2}	2	mA
Output Current (total of large current port)	ΣI_{OL1}	80	mA
Output Current (total)	ΣI_{OL}	120	mA
Output Current (total)	ΣI_{OH}	- 80	mA
Power Dissipation (Ta = 85°C)	P _D	600	mW
Soldering Temperature (10 s)	T _{SOLDER}	260	°C
Storage Temperature	T _{STG}	- 65 to 150	°C
Operating Temperature	T _{OPR}	- 40 to 85	°C

Note: The absolute maximum ratings are rated values which must not be exceeded during operation, even for an instant. Any one of the ratings must not be exceeded. If any absolute maximum rating is exceeded, a device may break down or its performance may be degraded, causing it to catch fire or explode resulting in injury to the user. Thus, when designing products which include this device, ensure that no absolute maximum rating value will ever be exceeded.

4.2 DC Characteristics (1/2)

Ta = - 40 to 85°C

Parameter	Symbol	Condition	Min	Typ. (Note)	Max	Unit
Power Supply Voltage ($\overline{AV}_{CC} = V_{CC}$ $\overline{AV}_{SS} = V_{SS} = 0\text{ V}$)	V _{CC}	$f_c = 4$ to 20 MHz	4.5		5.5	V
		$f_c = 4$ to 12.5 MHz	2.7			
Input Low Voltage	AD0 to 15	V _{IL}	$V_{CC} \geq 4.5\text{ V}$		0.8	V
	Port	V _{IL1}	$V_{CC} < 4.5\text{ V}$		0.6	
	KEY0 to 7, NMI, INT0 to 4	V _{IL2}	$V_{CC} = 2.7$ to 5.5 V	- 0.3	0.3 V _{CC}	
	\overline{EA}	V _{IL3}			0.3	
	X1	V _{IL4}			0.2 V _{CC}	
	RESET	V _{IL5}			0.1 V _{CC}	
AD0 to 15	V _{IH}	$V_{CC} \geq 4.5\text{ V}$			2.2	
Port	V _{IH1}	$V_{CC} \geq 4.5\text{ V}$	2.0			
Input High Voltage	KEY0 to 7, NMI, INT0 to 4	V _{IH2}	$V_{CC} = 2.7$ to 5.5 V		0.7 V _{CC}	V _{CC} + 0.3
	\overline{EA}	V _{IH3}			V _{CC} - 0.3	
	X1	V _{IH4}			0.8 V _{CC}	
	RESET	V _{IH5}			0.6 V _{CC}	
	AD0 to 15	V _{IH}				

Note: Typical values are for Ta = 25°C and V_{CC} = 5 V unless otherwise noted.

4.2 DC Characteristics (2/2)

Parameter	Symbol	Condition	Min	Typ. (Note 1)	Max	Unit	
Output Low Voltage	V_{OL}	$I_{OL} = 1.6 \text{ mA}$ ($V_{CC} = 5 \text{ V} \pm 10\%$)			0.45	V	
Output Low Current (PA0 to 7)	I_{OLA}	$V_{OL} = 1.0 \text{ V}$ ($V_{CC} = 5 \text{ V} \pm 10\%$) ($V_{CC} = 3 \text{ V} \pm 10\%$)	16 7			mA	
Output High Voltage	V_{OH1}	$I_{OH} = -400 \mu\text{A}$ ($V_{CC} = 3 \text{ V} \pm 10\%$)	2.4			V	
	V_{OH2}	$I_{OH} = -400 \mu\text{A}$ ($V_{CC} = 5 \text{ V} \pm 10\%$)	4.2				
Darlington Drive Current (8 Output Pins max)	I_{DAR} (Note 2)	$V_{EXT} = 1.5 \text{ V}$ $R_{EXT} = 1.1 \text{ k}\Omega$ ($V_{CC} = 5 \text{ V} \pm 10\%$ only)	-1.0		-3.5	mA	
Input Leakage Current	I_{LI}	$0.0 \leq V_{IN} \leq V_{CC}$		0.02	± 5	μA	
Output Leakage Current	I_{LO}	$0.2 \leq V_{IN} \leq V_{CC} - 0.2$		0.05	± 10		
Power Down Voltage (at Stop, RAM Back up)	V_{STOP}	$V_{IL2} = 0.2 V_{CC}$, $V_{IH2} = 0.8 V_{CC}$	2.0		6.0	V	
Pin Capacitance	C_{IO}	$f_c = 1 \text{ MHz}$			10	pF	
Schmitt Width KEYx, NMI, INTO to 4, RESET	V_{TH}		0.4	1.0		V	
Programmable Pull Up Resistance	R_{KH}	$V_{CC} = 5 \text{ V} \pm 10\%$	50		150	k Ω	
		$V_{CC} = 3 \text{ V} \pm 10\%$	100		300		
Normal Run Idle2 Idle1	I_{CC}	$V_{CC} = 5 \text{ V} \pm 10\%$ $f_c = 20 \text{ MHz}$		32	40	mA	
					24		30
					17		21
					4.5		7
Normal Run Idle2 Idle1	I_{CC}	$V_{CC} = 3 \text{ V} \pm 10\%$ $f_c = 12.5 \text{ MHz}$ (Typ. $V_{CC} = 3.0 \text{ V}$)		14	20	mA	
					10		14
					7		10
					2		3
Slow Run Idle2 Idle1	I_{CC}	$V_{CC} = 3 \text{ V} \pm 10\%$ $f_s = 32.768 \text{ kHz}$ (Typ. $V_{CC} = 3.0 \text{ V}$) at Boosting frequency = 1kHz		40	55	μA	
					30		42
					20		33
					10		24
Stop	I_{CC}	$T_a \leq 50^\circ\text{C}$ $T_a \leq 70^\circ\text{C}$ $T_a \leq 85^\circ\text{C}$			10	μA	
				0.2	20		
					50		

Note 1: Typical values are for $T_a = 25^\circ\text{C}$ and $V_{CC} = 5 \text{ V}$ unless otherwise noted.

Note 2: I_{DAR} is guaranteed for up to eight ports.

Note 3: Segment or Common output is not loaded.

Note 4: I_{CC} measurement conditions (NORMAL, SLOW): Only CPU is operational; output pins are open and input pins are fixed.

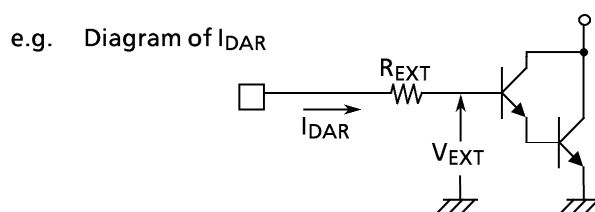

4.3 AC Electrical Characteristics

(1) $V_{CC} = 5\text{ V} \pm 10\%$

No.	Parameter	Symbol	Variable		16 MHz		20 MHz		Unit
			Min	Max	Min	Max	Min	Max	
1	Osc. Period (= x)	t_{OSC}	50	31250	62.5		50		ns
2	CLK width	t_{CLK}	$2x - 40$		85		60		ns
3	A0 to A23 Valid → CLK Hold	t_{AK}	$0.5x - 20$		11		5		ns
4	CLK Valid → A0 to A23 Hold	t_{KA}	$1.5x - 70$		24		5		ns
5	A0 to A15 Valid → ALE Fall	t_{AL}	$0.5x - 15$		16		10		ns
6	ALE fall → A0 to A15 Hold	t_{LA}	$0.5x - 20$		11		5		ns
7	ALE High Width	t_{LL}	$x - 40$		23		10		ns
8	ALE Fall → RD/WR Fall	t_{LC}	$0.5x - 25$		6		0		ns
9	RD/WR Rise → ALE Rise	t_{CL}	$0.5x - 20$		11		5		ns
10	A0 to A15 Valid → RD/WR Fall	t_{ACL}	$x - 25$		38		25		ns
11	A0 to A23 Valid → RD/WR Fall	t_{ACH}	$1.5x - 50$		44		25		ns
12	RD/WR Rise → A0 to A23 Hold	t_{CA}	$0.5x - 25$		6		0		ns
13	A0 to A15 Valid → D0 to D15 Input	t_{ADL}		$3.0x - 55$		133		95	ns
14	A0 to A23 Valid → D0 to D15 Input	t_{ADH}		$3.5x - 65$		154		110	ns
15	RD Fall → D0 to D15 Input	t_{RD}		$2.0x - 60$		65		40	ns
16	RD Low Pulse Width	t_{RR}	$2.0x - 40$		85		60		ns
17	RD Rise → D0 to D15 Hold	t_{HR}	0		0		0		ns
18	RD Rise → A0 to A15 Output	t_{RAE}	$x - 15$		48		35		ns
19	WR Low Pulse Width	t_{WW}	$2.0x - 40$		85		60		ns
20	D0 to D15 Valid → WR Rise	t_{DW}	$2.0x - 55$		70		45		ns
21	WR Rise → D0 to D15 Hold	t_{WD}	$0.5x - 15$		16		10		ns
22	A0 to A23 Valid → WAIT Input ⁽¹⁾ _(+n mode)	t_{AWH}		$3.5x - 90$		129		85	ns
23	A0 to A15 Valid → WAIT Input ⁽¹⁾ _(+n mode)	t_{AWL}		$3.0x - 80$		108		70	ns
24	RD/WR Fall → WAIT Hold ⁽¹⁾ _(+n mode)	t_{CW}	$2.0x + 0$		125		100		ns
25	A0 to A23 Valid → Port Input	t_{APH}		$2.5x - 120$		36		5	ns
26	A0 to A23 Valid → Port Hold	t_{APH2}	$2.5x + 50$		206		175		ns
27	WR Rise → Port Valid	t_{CP}		200		200		200	ns

AC Measuring Conditions

- Output Level: High 2.2 V/Low 0.8 V, $CL = 50\text{ pF}$
(However, $CL = 100\text{ pF}$ for AD0 to AD15, A0 to A23, ALE, RD, WR, HWR, CLK)
- Input Level: High 2.4 V/Low 0.45 V (AD0 to AD15)
High $0.8 \times V_{CC}$ /Low $0.2 \times V_{CC}$ (except for AD0 to AD15)

(2) $V_{CC} = 3V \pm 10\%$

No.	Parameter	Symbol	Variable		12.5 MHz		Unit
			Min	Max	Min	Max	
1	Osc. Period (= x)	t_{OSC}	80	31250	80		ns
2	CLK Width	t_{CLK}	$2x - 40$		120		ns
3	A0 to A23 Valid → CLK Hold	t_{AK}	$0.5x - 30$		10		ns
4	CLK Valid → A0 to A23 Hold	t_{KA}	$1.5x - 80$		40		ns
5	A0 to A15 Valid → ALE Fall	t_{AL}	$0.5x - 35$		5		ns
6	ALE Fall → A0 to A15 Hold	t_{LA}	$0.5x - 35$		5		ns
7	ALE High Width	t_{LL}	$x - 60$		20		ns
8	ALE Fall → RD/WR Fall	t_{LC}	$0.5x - 35$		5		ns
9	RD/WR Rise → ALE Rise	t_{CL}	$0.5x - 40$		0		ns
10	A0 to A15 Valid → RD/WR Fall	t_{ACL}	$x - 50$		30		ns
11	A0 to A23 Valid → RD/WR Fall	t_{ACH}	$1.5x - 50$		70		ns
12	RD/WR Rise → A0 to A23 Hold	t_{CA}	$0.5x - 40$		0		ns
13	A0 to A15 Valid → D0 to D15 Input	t_{ADL}		$3.0x - 110$		130	ns
14	A0 to A23 Valid → D0 to D15 Input	t_{ADH}		$3.5x - 125$		155	ns
15	RD Fall → D0 to D15 Input	t_{RD}		$2.0x - 115$		45	ns
16	RD Low Pulse Width	t_{RR}	$2.0x - 40$		120		ns
17	RD Rise → D0 to D15 Hold	t_{HR}	0		0		ns
18	RD Rise → A0 to A15 output	t_{RAE}	$x - 25$		55		ns
19	WR Low Pulse Width	t_{WW}	$2.0x - 40$		120		ns
20	D0 to D15 Valid → WR Rise	t_{DW}	$2.0x - 120$		40		ns
21	WR Rise → D0 to D15 Hold	t_{WD}	$0.5x - 40$		0		ns
22	A0 to A23 Valid → WAIT Input ⁽¹⁾ _{+n mode}	t_{AWH}		$3.5x - 130$		150	ns
23	A0 to A15 Valid → WAIT Input ⁽¹⁾ _{+n mode}	t_{AWL}		$3.0x - 100$		140	ns
24	RD/WR Fall → WAIT Hold ⁽¹⁾ _{+n mode}	t_{CW}	$2.0x + 0$		160		ns
25	A0 to A23 Valid → Port input	t_{APH}		$2.5x - 120$		80	ns
26	A0 to A23 Valid → Port Hold	t_{APH2}	$2.5x + 50$		250		ns
27	WR Rise → Port Valid	t_{CP}		200		200	ns

AC Measuring Conditions

- Output Level: High $0.7 \times V_{CC}$ /Low $0.3 \times V_{CC}$, CL = 50 pF
- Input Level: High $0.9 \times V_{CC}$ /Low $0.1 \times V_{CC}$

(1) Read Cycle

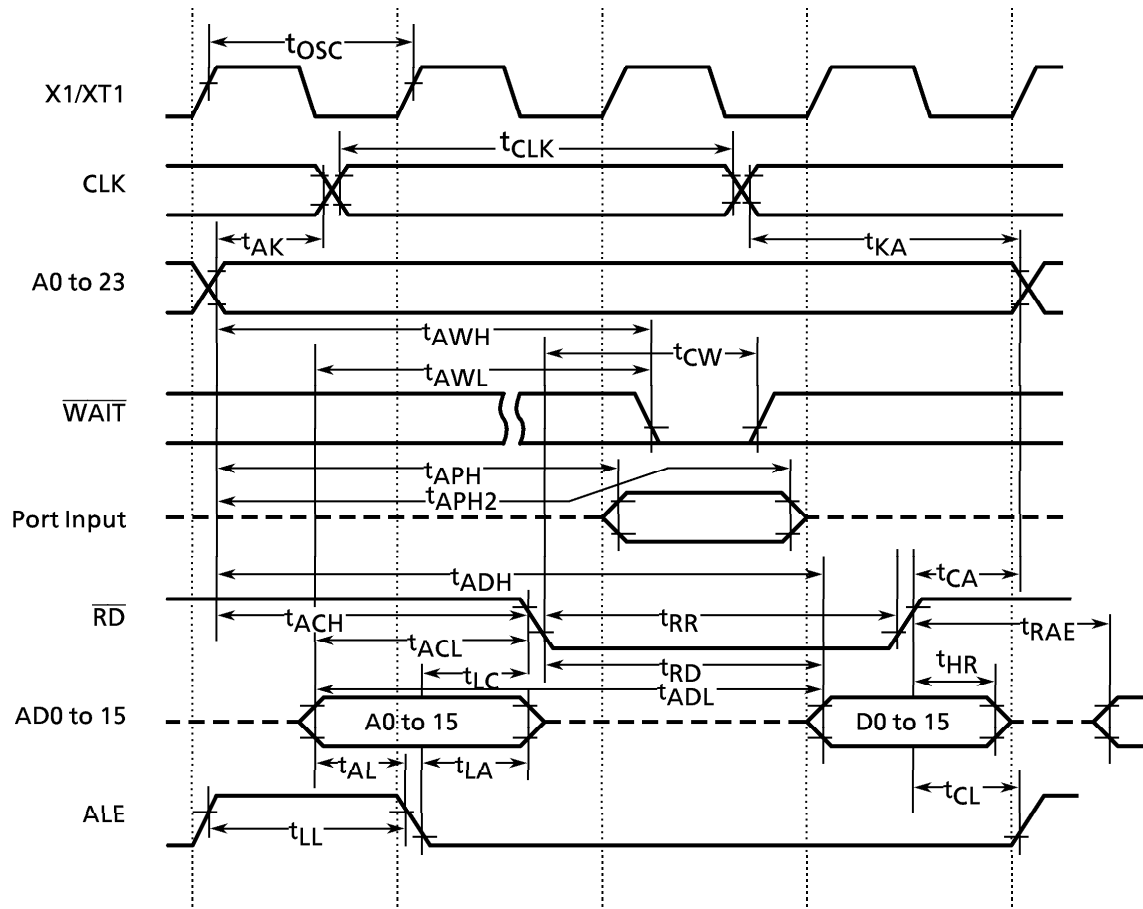

(2) Write Cycle

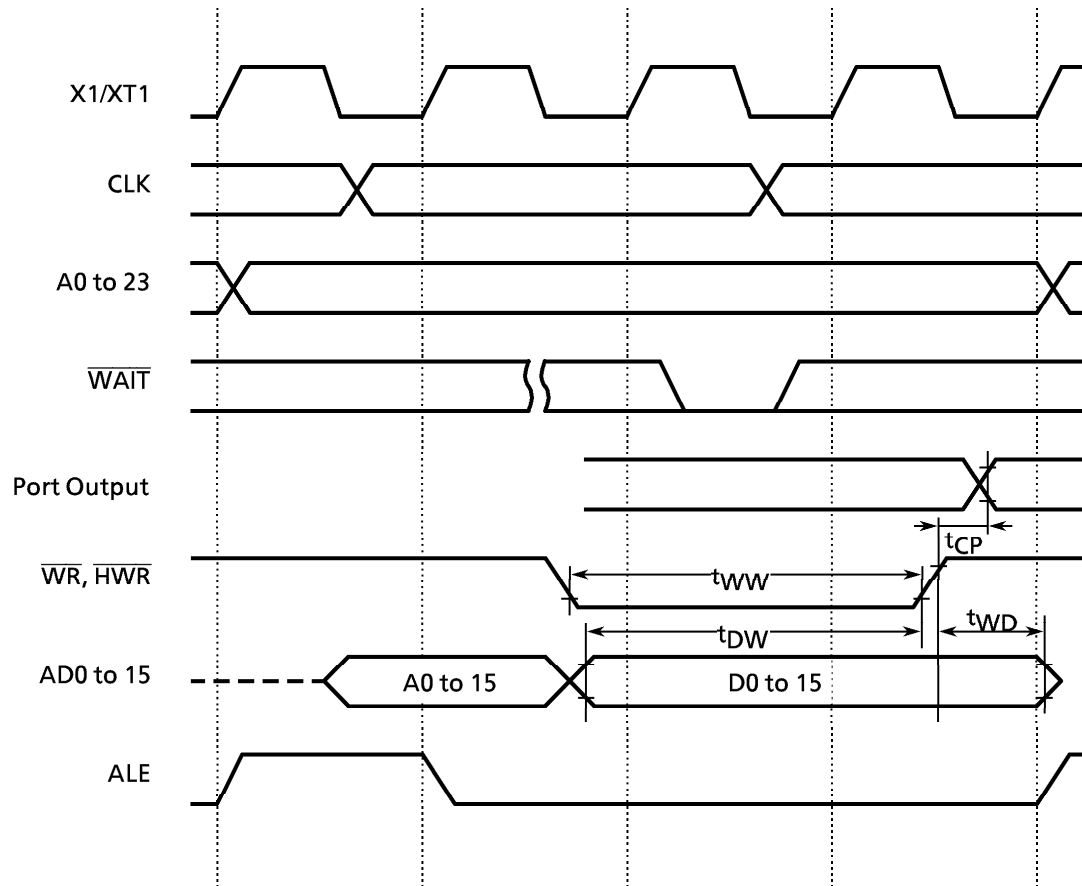

4.4 Serial Channel Timing

(1) I/O Interface Mode

① SCLK Input Mode

Parameter	Symbol	Variable		32.768 MHz ^(Note)		12.5 MHz		20 MHz		Unit
		Min	Max	Min	Max	Min	Max	Min	Max	
SCLK Cycle	t_{SCY}	16X		488		1.28		0.8		μs
Output Data → Rising Edge or Falling Edge* of SCLK	t_{OSS}	$t_{SCY}/2 - 5X - 50$		91.5 μs		190		100		ns
SCLK Rising Edge or Falling Edge* → Output Data Hold	t_{OHS}	5X - 100		152 μs		300		150		ns
SCLK Rising Edge or Falling Edge* → Input Data Hold	t_{HSR}	0		0		0		0		ns
SCLK Rising Edge or Falling Edge* → Effective Data Input	t_{SRD}		$t_{SCY} - 5X - 100$		336 μs		780		450	ns

Note: System clock is fs, or input clock to prescaler is divisor clock of fs.

*) The rising edge is used in SCLK Rising mode.
The falling edge is used SCLK Falling mode.

② SCLK Output Mode

Parameter	Symbol	Variable		32.768 MHz ^(Note)		12.5 MHz		20 MHz		Unit
		Min	Max	Min	Max	Min	Max	Min	Max	
SCLK Cycle (Programmable)	t_{SCY}	16X	8192X	488 μs	250 ms	1.28	655.36	0.8	409.6	μs
Output Data → SCLK Rising Edge	t_{OSS}	$t_{SCY} - 2X - 150$		427 μs		970		550		ns
SCLK Rising Edge → Output Data Hold	t_{OHS}	2X - 80		60 μs		80		20		ns
SCLK Rising Edge → Input Data Hold	t_{HSR}	0		0		0		0		ns
SCLK Rising Edge → Effective Data Input	t_{SRD}		$t_{SCY} - 2X - 150$		428 μs		970		550	ns

Note: System clock is fs, or input clock to prescaler is divisor clock of fs.

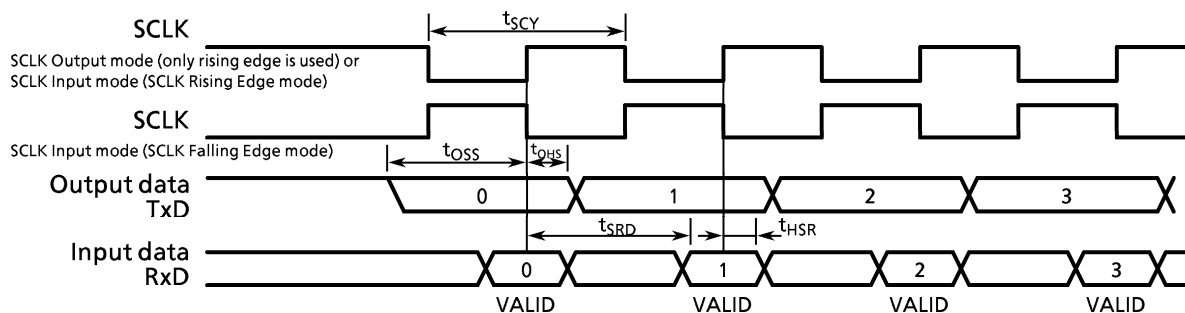

(2) UART Mode (SCLK0, 1 External Input)

Parameter	Symbol	Variable		32.768 kHz ^(Note)		12.5 MHz		20 MHz		Unit
		Min	Max	Min	Max	Min	Max	Min	Max	
SCLK Cycle	t_{SCY}	4x + 20		122 μs		340		220		ns
SCLK Low Level Pulse Width	t_{SCYL}	2x + 5		6 μs		165		105		ns
SCLK High Level Pulse Width	t_{SCYH}	2x + 5		6 μs		165		105		ns

Note: System clock is fs, or input clock to prescaler is divisor clock of fs.

4.5 AD Conversion Characteristics ($V_{SS} = 0\text{ V}$, $AV_{CC} = V_{CC}$, $AV_{SS} = V_{SS}$, $T_a = -40$ to 85°C)

$$AV_{CC} = V_{CC}, AV_{SS} = V_{SS}$$

Parameter	Symbol	Condition	Min	Typ.	Max	Unit
Analog Reference Voltage (+)	V_{REFH}	$V_{CC} = 5\text{ V} \pm 10\%$	$V_{CC} - 1.5\text{ V}$	V_{CC}	V_{CC}	V
		$V_{CC} = 3\text{ V} \pm 10\%$	$V_{CC} - 0.2\text{ V}$	V_{CC}	V_{CC}	
Analog Reference Voltage (-)	V_{REFL}	$V_{CC} = 5\text{ V} \pm 10\%$	V_{SS}			
		$V_{CC} = 3\text{ V} \pm 10\%$	V_{SS}			
Analog Input Voltage Range	V_{AIN}		V_{REFL}		V_{REFH}	
Analog Current for Analog Reference Voltage <VREFON> = 1	I_{REF} ($V_{REFL} = 0\text{ V}$)	$V_{CC} = 5\text{ V} \pm 10\%$		1.6	2.0	
		$V_{CC} = 3\text{ V} \pm 10\%$		1.0	1.5	
<VREFON> = 0		$V_{CC} = 2.7$ to 5.5 V		0.02	5.0	μA
Error (not including quantizing errors)	—	$V_{CC} = 5\text{ V} \pm 10\%$		± 1.0	± 3.0	LSB
		$V_{CC} = 3\text{ V} \pm 10\%$		± 1.0	± 5.0	

Note 1: $1\text{LSB} = (V_{REFH} - V_{REFL}) / 2^{10}$ [V]

Note 2: Minimum operation frequency

The operation of the AD converter is guaranteed only when f_c (high-frequency oscillator) is used. (It is not guaranteed when f_s is used.) Additionally, it is guaranteed when the clock frequency which is selected by the clock gear is 4 MHz or more.

Note 3: The value I_{CC} includes the current which flows through the AV_{CC} pin.

4.6 LCD Driver Characteristics

Charge and Pump Characteristics	Symbol	Min	Typ.	Max	Unit
Reference input voltage	V_{L1}	0.9		1.83	V
Output voltage V2 pin	V_{L2}		$2 \times V_{L1}$		V
V3 pin	V_{L3}		$3 \times V_{L1}$		V
External capacity C0, C1	C_{PMP}	0.1		1.0	μF
V1 pin	C_{VL1}	0.1		1.0	μF
V2 pin	C_{VL2}	0.1		1.0	μF
V3 pin	C_{VL3}	0.1		1.0	μF

Note: Output voltage and External capacity are not loaded.

4.7 Event Counter (TI0, TI2, TI4, TI6, TI8 to B)

Parameter	Symbol	Variable		12.5 MHz		20 MHz		Unit
		Min	Max	Min	Max	Min	Max	
Clock Cycle	t_{VCK}	$8X + 100$		740		500		ns
Low Level Clock Pulse Width	t_{VCKL}	$4X + 40$		360		240		ns
High Level Clock Pulse Width	t_{VCKH}	$4X + 40$		360		240		ns

4.8 Interrupt and Capture

(1) \overline{NMI} , INT0 to 4 interrupts, KEY interrupt

Parameter	Symbol	Variable		12.5 MHz		20 MHz		Unit
		Min	Max	Min	Max	Min	Max	
Low Level Pulse Width	t_{INTAL}	$4X$		320		200		ns
High Level Pulse Width	t_{INTAH}	$4X$		320		200		ns

(2) INT7 to B interrupts, capture

Parameter	Symbol	Variable		12.5 MHz		20 MHz		Unit
		Min	Max	Min	Max	Min	Max	
Low Level Pulse Width	t_{INTBL}	$4X + 100$		420		300		ns
High Level Pulse Width	t_{INTBH}	$4X + 100$		420		300		ns

4.9 SCOUT pin AC characteristics

Parameter	Symbol	Variable		12.5 MHz		20 MHz		Unit
		Min	Max	Min	Max	Min	Max	
High-Level Pulse Width $V_{CC} = 5V \pm 10\%$	t_{SCH}	$0.5X - 10$		30		15		ns
High-Level Pulse Width $V_{CC} = 3V \pm 10\%$		$0.5X - 20$		20		-	-	
Low-Level Pulse Width $V_{CC} = 5V \pm 10\%$	t_{SCL}	$0.5X - 10$		30		15		ns
Low-Level Pulse Width $V_{CC} = 3V \pm 10\%$		$0.5X - 20$		20		-	-	

Measurement condition

- Output level: High 2.2 V / Low 0.8 V, $C_L = 10$ pF

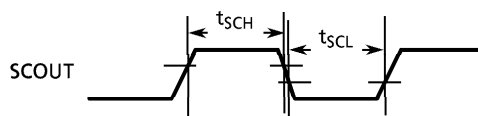

(2) Clock Synchronous 8-bit SIO Mode (Serial Bus Interface)

① SCK Input Mode

Parameter	Symbol	Variable		Unit
		Min	Max	
SCK Cycle	t_{SCY2}	2^5X		s
SCK Falling Edge → Output Data Hold	t_{OHS2}	$6X$		s
Output Data → SCK Rising Edge	t_{OSS2}	$t_{SCY2} - 6X$		s
SCK Rising Edge → Input Data Hold	t_{HSR2}	$6X$		ns
Input Data → SCK Rising Edge	t_{ISS2}	0		ns

② SCK Output Mode

Parameter	Symbol	Variable		Unit
		Min	Max	
SCK Cycle	t_{SCY2}	2^5X	$2^{11}X$	s
SCK Falling Edge → Output Data Hold	t_{OHS2}	$2X$		s
Output Data → SCK Rising Edge	t_{OSS2}	$t_{SCY2} - 2X$		s
SCK Rising Edge → Input Data Hold	t_{HSR2}	$2X$		s
Input Data → SCK Rising Edge	t_{ISS2}	0		ns

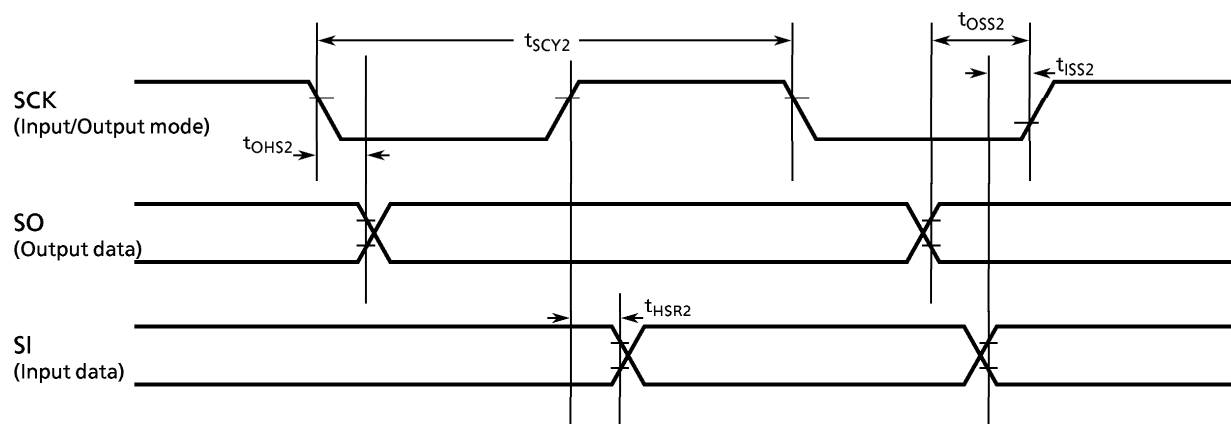

4.11 Operation in PROM Mode

(1) DC and AC characteristics in Read operation

Ta = 25 ± 5°C Vcc = 5 V ± 10%

Parameter	Symbol	Condition	Min	Max	Unit
V _{pp} Read Voltage	V _{pp}	-	4.5	5.5	V
Input High Voltage (A0 to A16, \overline{CE} , \overline{OE} , \overline{PGM})	V _{IH1}	-	2.2	V _{CC} + 0.3	V
Input Low Voltage (A0 to A16, \overline{CE} , \overline{OE} , \overline{PGM})	V _{IL1}	-	-0.3	0.8	V
Address to Output Delay	t _{ACC}	C _L = 50 pF	-	2.25T _{CYC} + α	ns

T_{CYC} = 400 ns (10 MHz Clock)
α = 200 ns

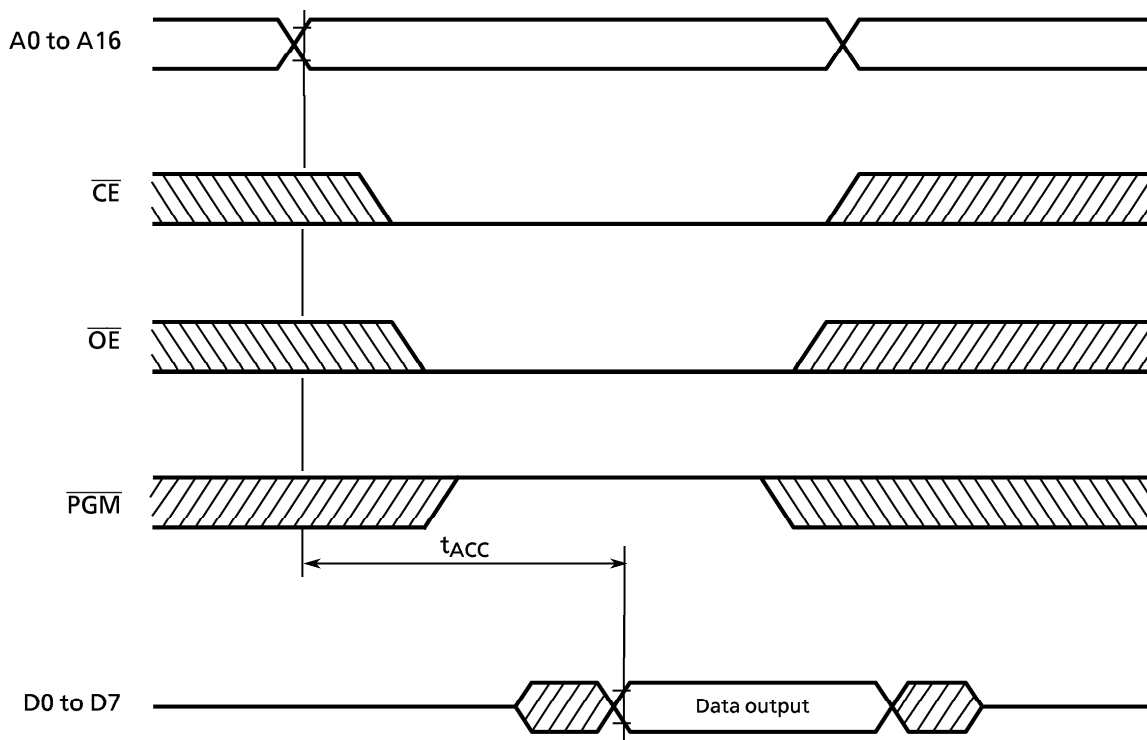

(2) DC and AC characteristics in Programming

Ta = 25 ± 5°C Vcc = 6.25 V ± 0.25 V

Parameter	Symbol	Condition	Min	Typ.	Max	Unit
Programming Supply Voltage	V _{PP}	-	12.50	12.75	13.00	V
Input High Voltage (D0 to D7, A0 to A16, \overline{CE} , \overline{OE} , \overline{PGM})	V _{IH}	-	2.6		V _{CC} + 0.3	V
Input Low Voltage (D0 to D7, A0 to A16, \overline{CE} , \overline{OE} , \overline{PGM})	V _{IL}	-	-0.3		0.8	V
V _{CC} Supply Current	I _{CC}	f _c = 10 MHz	-		50	mA
V _{PP} Supply Current	I _{PP}	V _{PP} = 13.00 V	-		50	mA
\overline{PGM} Program Pulse Width	t _{PW}	C _L = 50 pF	0.095	0.1	0.105	ms

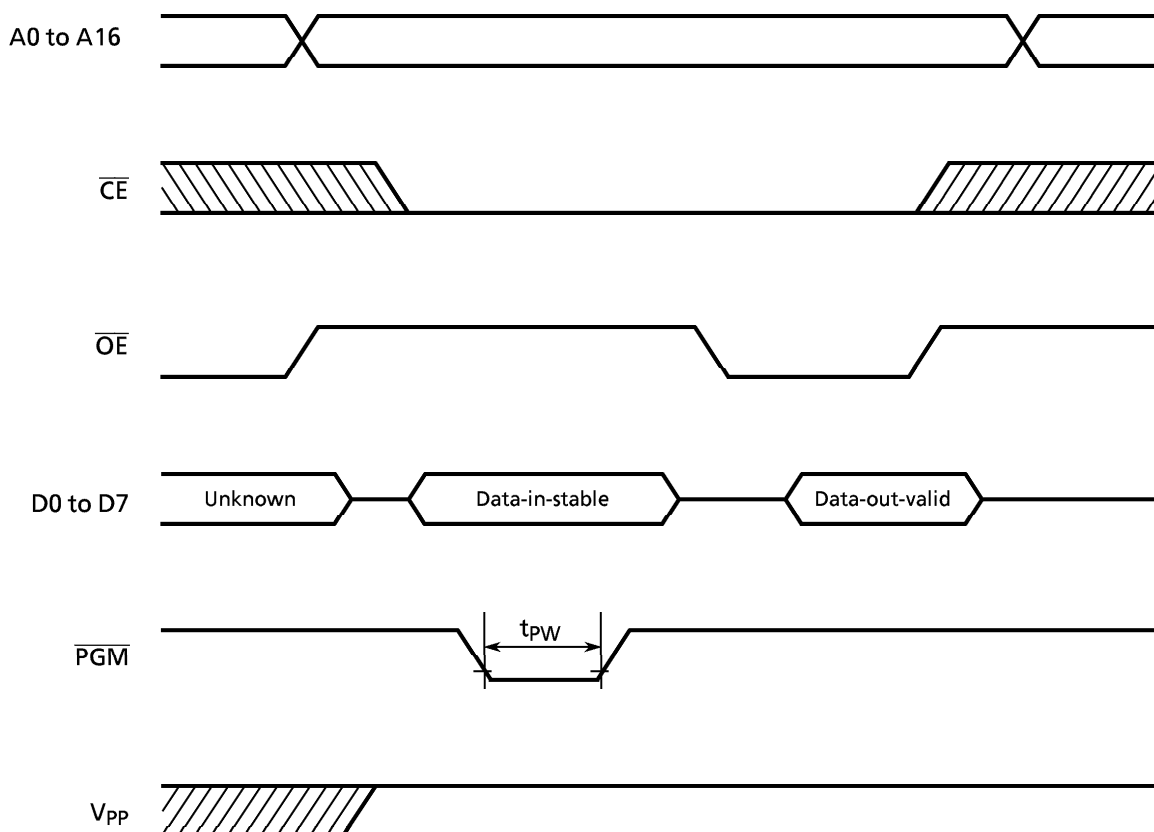

Note 1: The power supply of V_{PP} (12.75 V) must be turned on at the same time or the later time for a power supply of V_{CC} and must be turned off at the same time or early time for a power supply of V_{CC}.

Note 2: The device suffers a damage taking out and putting in on the condition of V_{PP} = 12.75 V.

Note 3: The maximum spec of V_{PP} pin is 14.0 V. Be carefull a overshoot at the programming.