



L6902D

UP TO 1A SWITCHING REGULATOR WITH ADJUSTABLE CURRENT LIMIT

- UP TO 1A OUTPUT CURRENT
- OPERATING INPUT VOLTAGE FROM 8V TO 36V
- PRECISE 3.3V ($\pm 2\%$) REFERENCE VOLTAGE
- 5% OUTPUT CURRENT ACCURACY
- OUTPUT VOLTAGE ADJUSTABLE FROM 1.235V TO 34V
- 250KHz INTERNALLY FIXED FREQUENCY
- VOLTAGE FEEDFORWARD
- ZERO LOAD CURRENT OPERATION
- ADJUSTABLE CURRENT LIMIT
- PROTECTION AGAINST FEEDBACK DISCONNECTION
- THERMAL SHUTDOWN

APPLICATIONS

- CHARGERS FOR NiCd, NiMH BATTERIES AND PREREGULATOR FOR LITHIUM-ION BATTERIES
- ADJUSTABLE CURRENT GENERATOR
- SIMPLE STEP-DOWN CONVERTERS WITH ADJUSTABLE CURRENT LIMIT
- BATTERY EQUIPPED SYSTEMS
- DISTRIBUTED POWER SUPPLY
- MOBILE PC & SUBNOTEBOOK

DESCRIPTION

The L6902D is a complete and simple step down switching regulator with adjustable current limit. Based on a voltage mode structure it integrates a cur-

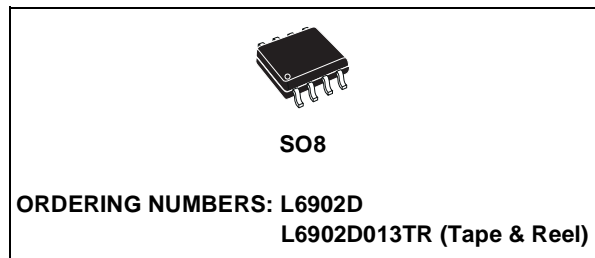

rent error amplifier to have a constant voltage and constant current control.

By means of an on board current sense resistor and the availability of the current sense pins (both compatible to V_{CC} and for $Cs-$ compatible with GND too) a current limit programming is very simple and accurate ($\pm 5\%$). Moreover constant current control can be used to charge NiMH and NiCd batteries.

The device can be used as a standard DC/DC converter with adjustable current limit (set by using the external sense resistor).

The internal robust P-Channel DMOS transistor with a typical of $250m\Omega$ assures high efficiency and a minimal dropout even at high output current level. The internal limiting current (latched function) of typical value of 2.5A protects the device from accidental output short circuit avoiding dangerous loads damage.

If the temperature of the chip goes higher than a fixed internal threshold ($150^{\circ}C$ with $20^{\circ}C$ hysteresis), the power stage is turned off.

TEST AND APPLICATION CIRCUIT

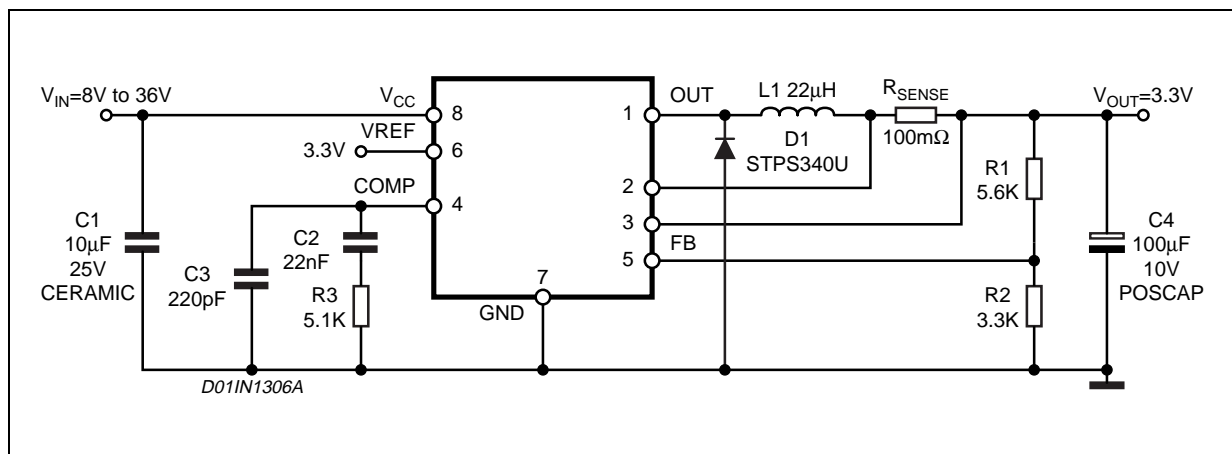

L6902D

DESCRIPTION (Continued)

Other protections beside thermal shutdown complete the device for a safe and reliable application: overvoltage protection, frequency fallback overcurrent protection and protection vs. feedback disconnection.

The internal fixed switching frequency of 250KHz, and the SO-8 package pin allow to built an ultra compact DC/DC converter with a minimum board space.

PIN CONNECTION

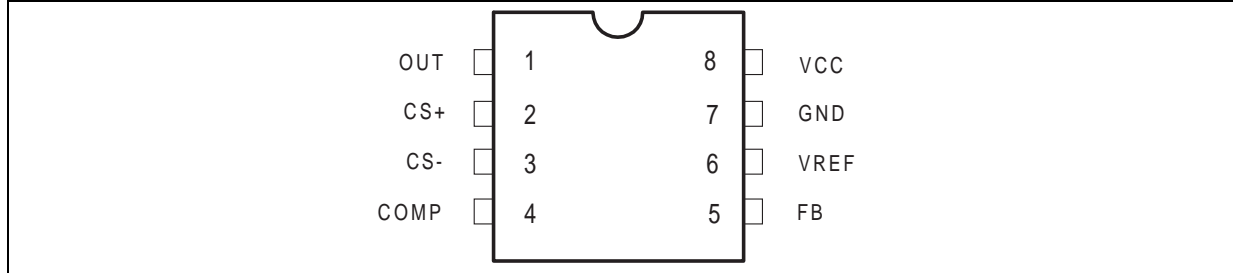

PIN DESCRIPTION

N°	Pin	Function
1	OUT	Regular Output
2	CS+	Current Error Amplifier input (current sense at higher voltage)
3	CS-	Current Error Amplifier input (current sense at lower voltage)
4	COMP	E/A output to be used for frequency compensation
5	FB	Stepdown feedback input. Connecting directly to this pin results in an output voltage of 1.235V. An external resistive divider is required for higher output voltages. In this case: $V_{out} = V_{FB} \cdot \left(1 + \frac{R1}{R2}\right) = 1.235V \left(1 + \frac{R1}{R2}\right)$
6	VREF	3.3V VREF. No cap is need for stability.
7	GND	Ground
8	VCC	Unregulated DC input voltage.

THERMAL DATA

Symbol	Parameter	Value	Unit
R _{th j-amb}	Thermal Resistance Junction to Ambient Max.	110 (*)	°C/W

(*) Package mounted on board.

ABSOLUTE MAXIMUM RATINGS

Symbol	Parameter	Value	Unit
V ₈	Input Voltage	40	V
V ₁	Output DC voltage Output peak voltage at t = 0.1μs	-1 to 40 -5 to 40	V V
I ₁	Maximum output current	Internally limited	
V ₄ , V ₅	Analog pins	4	V
V ₂ , V ₃	Analog pins	-0.3V to V _{CC}	V
P _{tot}	Power dissipation at T _{amb} ≤ 70 °C	0.7	W
T _j	Operating junction temperature range	-40 to 150	°C
T _{stg}	Storage temperature range	-55 to 150	°C

INTERNAL BLOCK DIAGRAM

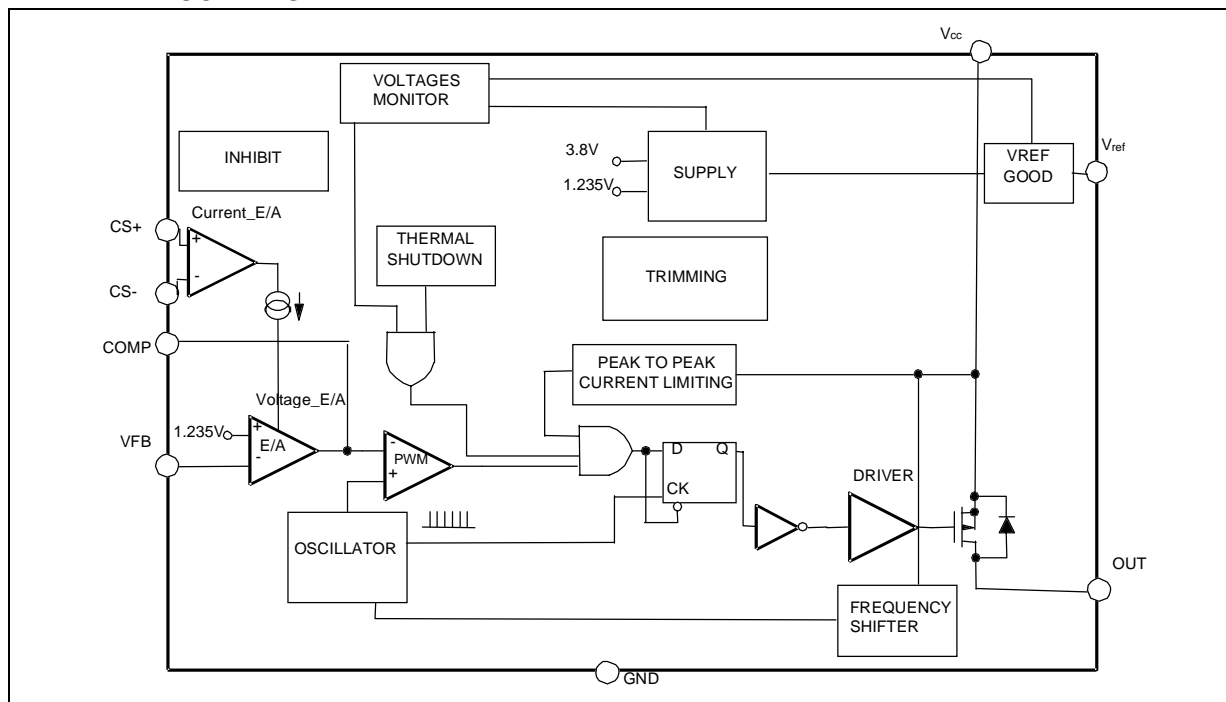

ELECTRICAL CHARACTERISTICS

($T_j = 25^\circ\text{C}$, $V_{CC} = 12\text{V}$, unless otherwise specified.) (•) Specification Referred to T_j from 0 to 125°C .

Symbol	Parameter	Test Condition	Min.	Typ.	Max.	Unit	
V_{CC}	Operating input voltage range	$V_O = 1.235\text{V}$; $I_O = 1\text{A}$	• 8		36	V	
V_d	Dropout voltage	$V_{CC} = 8\text{V}$; $I_O = 1\text{A}$	•	0.25	0.5	V	
I_O	Operating charging current	$R_{\text{sense}} = 0.1\Omega$	•	0.95	1	1.05	A
			•	0.92		1.08	A
I_l	Maximum limiting current	$V_{CC} = 8\text{V}$ to 36V	• 2	2.5	3.2	A	
f_s	Switching frequency		•	212	250	287	kHz
				225	250	275	kHz
d	Duty cycle		0		100	%	
DYNAMIC CHARACTERISTICS							
V_5	Voltage feedback (FB)	$8\text{V} < V_{CC} < 36\text{V}$, $20\text{mA} < I_O < 1\text{A}$		1.21	1.235	1.259	V
			•	1.198	1.235	1.272	V
η	Efficiency	$V_O = 5\text{V}$, $V_{CC} = 12\text{V}$		90		%	
DC CHARACTERISTICS							
I_{qop}	Total operating quiescent current		•	3	5	mA	
I_q	Quiescent current	Duty cycle = 0; $V_{FB} = 1.5\text{V}$			2.7	mA	

ELECTRICAL CHARACTERISTICS (continued)

(T_j = 25°C, V_{CC} = 12V, unless otherwise specified.) (*) Specification Referred to T_j from 0 to 125°C.

Symbol	Parameter	Test Condition	Min.	Typ.	Max.	Unit	
VOLTAGE ERROR AMPLIFIER							
V _{OH}	High level output voltage	V _{FB} = 1V		3.6		V	
V _{OL}	Low level output voltage	V _{FB} = 1.5			0.4	V	
I _{o source}	Source output current	V _{comp} = 1.9V; V _{FB} = 1V		200	300	μA	
I _{o sink}	Sink output current	V _{comp} = 1.9V; V _{FB} = 1.5V		1	1.5	mA	
I _b	Source bias current			2.5	4	μA	
	DC open loop gain	R _L = 0		50	58	dB	
g _m	Transconductance	I _{comp} = -0.1 to 0.1mA V _{comp} = 1.9V		2.3		mS	
CURRENT ERROR AMPLIFIER							
V _{offs}	Input offset voltage	V _{CS-} = 1.8V; V _{CS+} = V _{comp}		90	100	110	mV
I _{CS+}	CS+ Output Current	I _O = 1A, R _{sense} = 100mΩ V _{out} < V _{CC} -2V			1.5	3	μA
I _{CS-}	CS- Output Current	I _O = 1A, R _{sense} = 100mΩ V _{out} < V _{CC} -2V			1.5	3	μA
REFERENCE SECTION							
	Reference Voltage			3.234	3.3	3.366	V
		I _{REF} = 0 to 5mA V _{CC} = 8V to 36V	•	3.2	3.3	3.399	V
	Line Regulation	I _{REF} = 0mA V _{CC} = 8V to 36V			5	10	mV
	Load Regulation	I _{REF} = 0 to 5mA			8	15	mV
	Short Circuit Current			10			mA

DIM.	mm			inch		
	MIN.	TYP.	MAX.	MIN.	TYP.	MAX.
A			1.75			0.069
a1	0.1		0.25	0.004		0.010
a2			1.65			0.065
a3	0.65		0.85	0.026		0.033
b	0.35		0.48	0.014		0.019
b1	0.19		0.25	0.007		0.010
C	0.25		0.5	0.010		0.020
c1	45° (typ.)					
D (1)	4.8		5.0	0.189		0.197
E	5.8		6.2	0.228		0.244
e		1.27			0.050	
e3		3.81			0.150	
F (1)	3.8		4.0	0.15		0.157
L	0.4		1.27	0.016		0.050
M			0.6			0.024
S	8° (max.)					

(1) D and F do not include mold flash or protrusions. Mold flash or protrusions shall not exceed 0.15mm (.006inch).

OUTLINE AND MECHANICAL DATA

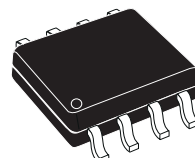

SO8

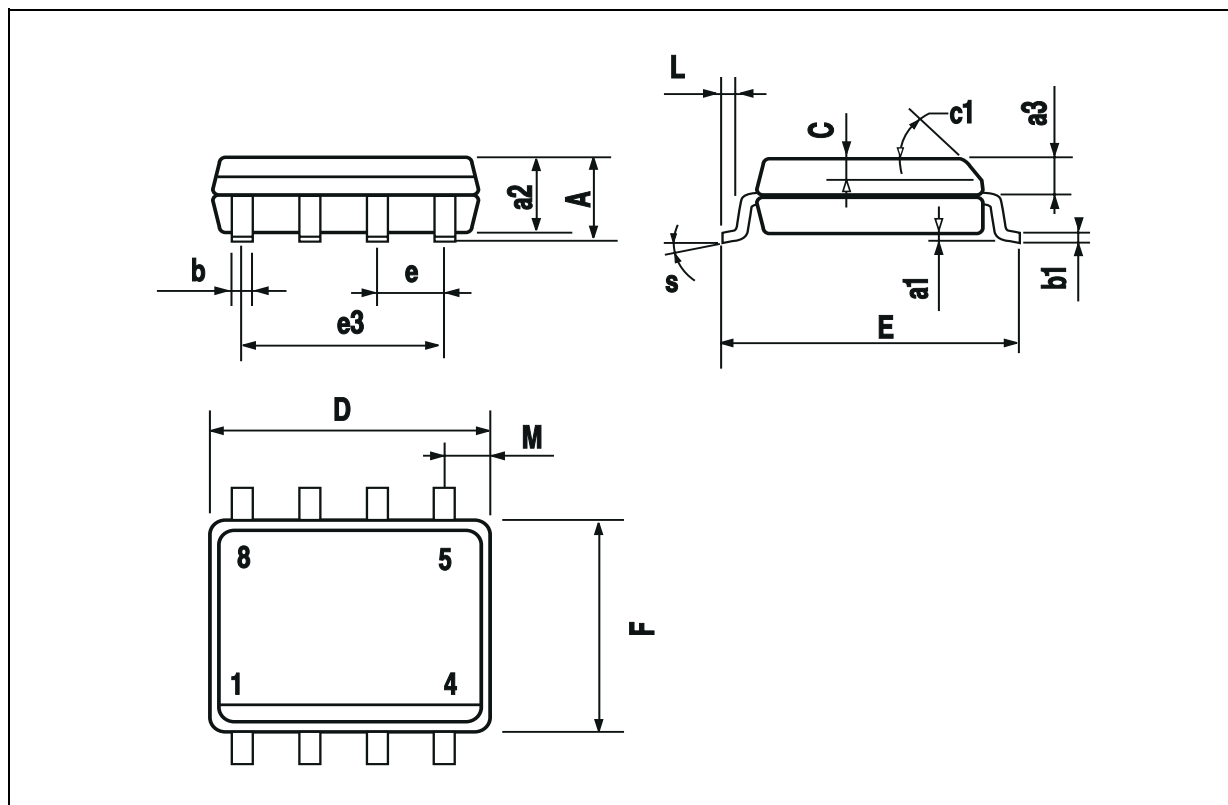

Information furnished is believed to be accurate and reliable. However, STMicroelectronics assumes no responsibility for the consequences of use of such information nor for any infringement of patents or other rights of third parties which may result from its use. No license is granted by implication or otherwise under any patent or patent rights of STMicroelectronics. Specifications mentioned in this publication are subject to change without notice. This publication supersedes and replaces all information previously supplied. STMicroelectronics products are not authorized for use as critical components in life support devices or systems without express written approval of STMicroelectronics.

The ST logo is a registered trademark of STMicroelectronics
© 2002 STMicroelectronics - All Rights Reserved

STMicroelectronics GROUP OF COMPANIES
Australia - Brazil - Canada - China - Finland - France - Germany - Hong Kong - India - Israel - Italy - Japan -Malaysia - Malta - Morocco -
Singapore - Spain - Sweden - Switzerland - United Kingdom - United States.
<http://www.st.com>