



# CMOS OCTAL DUAL-SUPPLY BUS TRANSCEIVER WITH CONFIGURABLE OUTPUT VOLTAGE, 3-STATE OUTPUTS, 3.3V AND 5V I/O

**IDT74LVCC4245A**

### FEATURES:

- 0.5 MICRON CMOS Technology
- $V_{CCA} = 5V \pm 0.5V$
- $V_{CCB} = 2.7V$  to  $5.5V$
- CMOS power levels ( $0.4\mu W$  typ. static)
- Rail-to-rail output swing for increased noise margin
- All inputs, outputs, and I/O are 5V tolerant
- Supports hot insertion
- Available in SSOP, QSOP, and TSSOP packages

### DRIVE FEATURES:

- High Output Drivers:  $\pm 24mA$
- Reduced system switching noise

### APPLICATIONS:

- 5V and 3.3V mixed voltage systems
- Data communication and telecommunication systems

### DESCRIPTION:

The LVCC4245A is manufactured using advanced dual metal CMOS technology. This 8-bit (octal) noninverting bus transceiver contains two separate power-supply rails. The configurable B port is designed to track  $V_{CCB}$ , which accepts voltages from 3V to 5V, and the A port is dedicated to accept a 5V supply level. This allows for translation from a 3.3V to a 5V system environment and vice-versa.

This LVCC4245A is ideal for asynchronous communication between two data buses (A and B). The device transmits data from A to B or from B to A, depending on the logic level at the direction-control (DIR) input. The output-enable ( $\overline{OE}$ ) input can be used to disable the device so the buses are effectively isolated.

The LVCC4245A has been designed with a  $\pm 24mA$  output driver. This driver is capable of driving a moderate to heavy load while maintaining speed performance.

## FUNCTIONAL BLOCK DIAGRAM

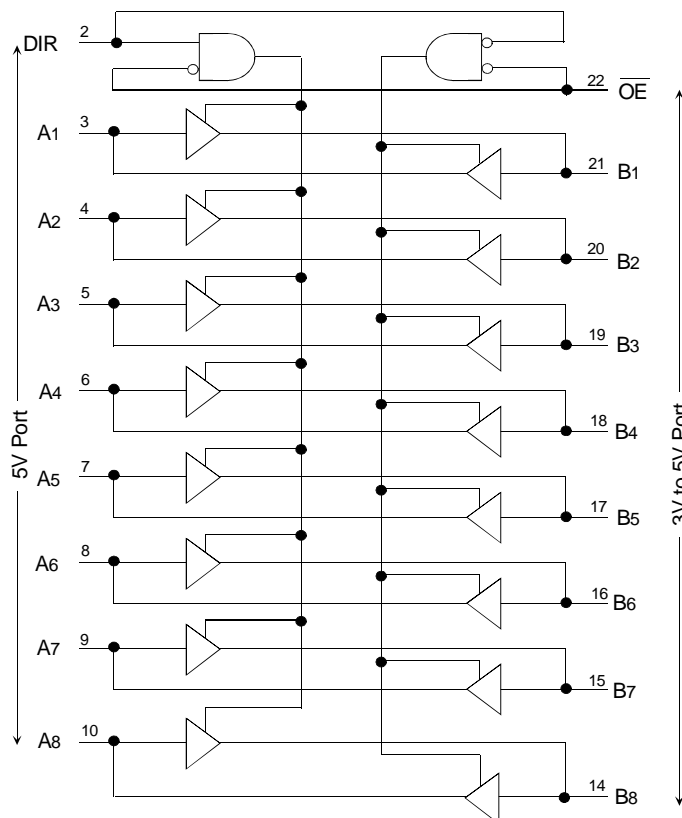

## PIN CONFIGURATION

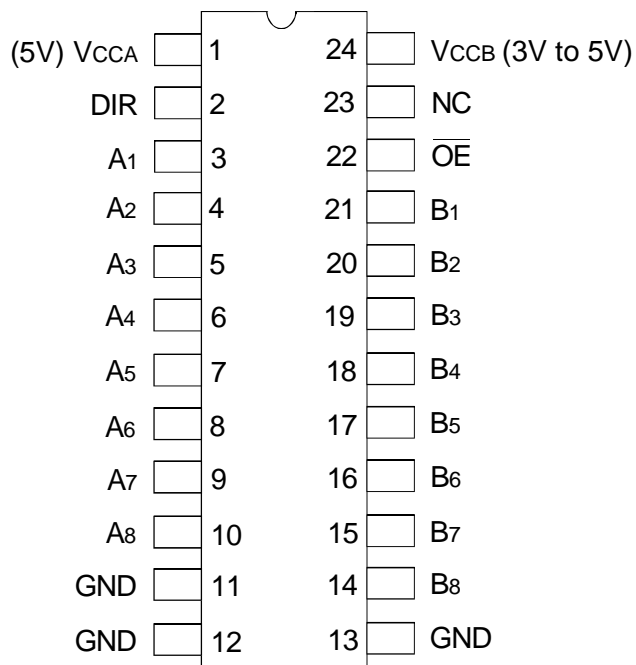

SSOP/ QSOP/ TSSOP  
TOP VIEW

## ABSOLUTE MAXIMUM RATINGS FOR V<sub>CCB</sub> OR V<sub>CCB</sub>(<sup>1</sup>)

Symbol	Description	Max	Unit
V <sub>TERM</sub>	Terminal Voltage with Respect to GND	-0.5 to +6	V
T <sub>STG</sub>	Storage Temperature	-65 to +150	°C
I <sub>OUT</sub>	DC Output Current	-50 to +50	mA
I <sub>IK</sub> I <sub>OK</sub>	Continuous Clamp Current, V <sub>I</sub> < 0 or V <sub>O</sub> < 0	-50	mA
I <sub>CC</sub> I <sub>SS</sub>	Continuous Current through each V <sub>CC</sub> or GND	±100	mA

**NOTE:**

- Stresses greater than those listed under ABSOLUTE MAXIMUM RATINGS may cause permanent damage to the device. This is a stress rating only and functional operation of the device at these or any other conditions above those indicated in the operational sections of this specification is not implied. Exposure to absolute maximum rating conditions for extended periods may affect reliability.

## CAPACITANCE (T<sub>A</sub> = +25°C, F = 1.0MHz)

Symbol	Parameter <sup>(1)</sup>	Conditions	Typ.	Max.	Unit
C <sub>IN</sub>	Input Capacitance	V <sub>IN</sub> = 0V	5	—	pF
C <sub>I/O</sub>	I/O Port Capacitance	V <sub>IN</sub> = 0V	11	—	pF

**NOTE:**

- As applicable to the device type.

## PIN DESCRIPTION

Pin Names	Description
$\overline{OE}$	Output Enable Input (Active LOW)
DIR	Direction Control Input
A <sub>x</sub>	Port A Inputs or 3-State Outputs
B <sub>x</sub>	Port B Inputs or 3-State Outputs
NC	No Internal Connection

## FUNCTION TABLE<sup>(1)</sup>

Inputs		Outputs
$\overline{OE}$	DIR	
L	L	Bus B Data to Bus A
L	H	Bus A Data to Bus B
H	X	High Z state

**NOTE:**

- H = HIGH Voltage Level  
L = LOW Voltage Level  
X = Don't Care

## DC ELECTRICAL CHARACTERISTICS OVER OPERATING RANGE (A PORT)

Following Conditions Apply Unless Otherwise Specified:

Operating Condition:  $T_A = -40^{\circ}\text{C}$  to  $+85^{\circ}\text{C}$ ,  $V_{CCA} = 4.5\text{V}$  to  $5.5\text{V}^{(1)}$

Symbol	Parameter	Test Conditions		Min.	Typ. <sup>(2)</sup>	Max.	Unit
$V_{IH}$	Input HIGH Voltage Level	$V_{CCA} = 4.5\text{V}$ , $V_{CCB} = 2.7\text{V}$	$V_{OB} \leq 0.1\text{V}$ or $V_{OB} \geq V_{CCB} - 0.1\text{V}$	2	—	—	V
		$V_{CCA} = 4.5\text{V}$ , $V_{CCB} = 3.6\text{V}$		2	—	—	
		$V_{CCA} = 5.5\text{V}$ , $V_{CCB} = 5.5\text{V}$		2	—	—	
$V_{IL}$	Input LOW Voltage Level	$V_{CCA} = 4.5\text{V}$ , $V_{CCB} = 2.7\text{V}$		—	—	0.8	V
		$V_{CCA} = 4.5\text{V}$ , $V_{CCB} = 3.6\text{V}$		—	—	0.8	
		$V_{CCA} = 5.5\text{V}$ , $V_{CCB} = 5.5\text{V}$		—	—	0.8	
$I_{IH}$ $I_{IL}$	Input Leakage Current (Control Inputs)	$V_{CCA} = 5.5\text{V}$ $V_{CCB} = 3.6\text{V}$ or $5.5\text{V}$	$V_I = 0$ to $5.5\text{V}$	—	—	$\pm 1$	$\mu\text{A}$
$I_{OZH}$ $I_{OZL}$	High Impedance Output Current (3-State Output pins)	$V_{CCA} = 5.5\text{V}$ $V_{CCB} = 3.6\text{V}$	$V_O = 0$ to $5.5\text{V}$	—	—	$\pm 5$	$\mu\text{A}$
$V_H$	Input Hysteresis	$V_{CCA} = 5.0\text{V}$		—	100	—	mV
$I_{CCL}$ $I_{CCH}$	Quiescent Power Supply Current	$V_{CCA} = 5.5\text{V}$ $V_{CCB} = 3.6\text{V}$ or $5.5\text{V}$	$V_{IN} = \text{GND}$ or $V_{CCA}$ $I_{OB} = 0$	—	—	80	$\mu\text{A}$
$\Delta I_{CC}$	Quiescent Power Supply Current Variation	One input at $3.4\text{V}$ , other inputs at $V_{CCA}$ or GND		—	—	1.5	mA

**NOTES:**

- $V_{CCB} = 2.7\text{V}$  to  $5.5\text{V}$  unless otherwise noted.
- Typical values are at  $V_{CCA} = 5\text{V}$ ,  $+25^{\circ}\text{C}$  ambient.

## DC ELECTRICAL CHARACTERISTICS OVER OPERATING RANGE (B PORT)

Following Conditions Apply Unless Otherwise Specified:

Operating Condition:  $T_A = -40^{\circ}\text{C}$  to  $+85^{\circ}\text{C}$ ,  $V_{CCB} = 2.7\text{V}$  to  $5.5\text{V}^{(1)}$

Symbol	Parameter	Test Conditions		Min.	Typ. <sup>(2)</sup>	Max.	Unit
$V_{IH}$	Input HIGH Voltage Level	$V_{CCB} = 2.7\text{V}$ , $V_{CCA} = 4.5\text{V}$	$V_{OA} \leq 0.1\text{V}$ or $V_{OA} \geq V_{CCA} - 0.1\text{V}$	2	—	—	V
		$V_{CCB} = 3.6\text{V}$ , $V_{CCA} = 4.5\text{V}$		2	—	—	
		$V_{CCB} = 5.5\text{V}$ , $V_{CCA} = 5.5\text{V}$		3.85	—	—	
$V_{IL}$	Input LOW Voltage Level	$V_{CCB} = 2.7\text{V}$ , $V_{CCA} = 4.5\text{V}$		—	—	0.8	V
		$V_{CCB} = 3.6\text{V}$ , $V_{CCA} = 4.5\text{V}$		—	—	0.8	
		$V_{CCB} = 5.5\text{V}$ , $V_{CCA} = 5.5\text{V}$		—	—	1.65	
$I_{OZH}$ $I_{OZL}$	High Impedance Output Current (3-State Output pins)	$V_{CCB} = 3.6\text{V}$ $V_{CCA} = 5.5\text{V}$	$V_O = 0$ to $5.5\text{V}$	—	—	$\pm 5$	$\mu\text{A}$
$V_H$	Input Hysteresis	$V_{CCB} = 3.3\text{V}$		—	100	—	mV
$I_{CCL}$ $I_{CCH}$	Quiescent Power Supply Current	$V_{CCB} = 3.6\text{V}$ or $5.5\text{V}$ $V_{CCA} = 5.5\text{V}$	$V_{IN} = \text{GND}$ or $V_{CCB}$ $I_{OA} = 0$	—	—	80	$\mu\text{A}$
$\Delta I_{CC}$	Quiescent Power Supply Current Variation	One input at $V_{CCB} - 0.6\text{V}$ , other inputs at $V_{CCB}$ or GND		—	—	500	$\mu\text{A}$

**NOTES:**

- $V_{CCA} = 4.5\text{V}$  to  $5.5\text{V}$  unless otherwise noted.
- Typical values are at  $V_{CCB} = 3.3\text{V}$ ,  $+25^{\circ}\text{C}$  ambient.

## OUTPUT DRIVE CHARACTERISTICS (A PORT)

Symbol	Parameter	Test Conditions <sup>(1)</sup>			Min.	Max.	Unit
VOH	Output HIGH Voltage (B port to A port)	VCCA = 4.5V	VCCB = 3V	IOH = - 0.1mA	4.4	—	V
				IOH = - 24mA	3.76	—	
VOL	Output LOW Voltage (B port to A port)	VCCA = 4.5V	VCCB = 3V	IOH = 0.1mA	—	0.1	V
				IOH = 24mA	—	0.44	

**NOTE:**  
1. VIH and VIL must be within the min. or max. range shown in the DC ELECTRICAL CHARACTERISTICS OVER OPERATING RANGE table for the appropriate Vcc range.  
TA = - 40°C to + 85°C.

## OUTPUT DRIVE CHARACTERISTICS (B PORT)

Symbol	Parameter	Test Conditions <sup>(1)</sup>			Min.	Max.	Unit
VOH	Output HIGH Voltage (A port to B port)	VCCB = 3V	VCCA = 4.5V	IOH = - 0.1mA	2.9	—	V
		VCCB = 2.7V	VCCA = 4.5V	IOH = - 12mA	2.2	—	
		VCCB = 3V	VCCA = 4.5V		2.46	—	
		VCCB = 2.7V	VCCA = 4.5V	IOH = - 24mA	2.1	—	
		VCCB = 3V	VCCA = 4.5V		2.25	—	
		VCCB = 4.5V	VCCA = 4.5V		3.76	—	
VOL	Output LOW Voltage (A port to B port)	VCCB = 3V	VCCA = 4.5V	IOH = 0.1mA	—	0.1	V
		VCCB = 2.7V	VCCA = 4.5V	IOH = 12mA	—	0.44	
		VCCB = 2.7V	VCCA = 4.5V	IOH = 24mA	—	0.5	
		VCCB = 3V	VCCA = 4.5V		—	0.44	
		VCCB = 4.5V	VCCA = 4.5V		—	0.44	

**NOTE:**  
1. VIH and VIL must be within the min. or max. range shown in the DC ELECTRICAL CHARACTERISTICS OVER OPERATING RANGE table for the appropriate Vcc range.  
TA = - 40°C to + 85°C, VCCA = 4.5V.

## OPERATING CHARACTERISTICS, TA = 25°C

Symbol	Parameter	Test Conditions	VCCA = 5V, VCCB = 3.3V	Unit
			Typical	
CPD	Power Dissipation Capacitance per Transceiver Outputs enabled	CL = 0pF, f = 10Mhz	20	pF
CPD	Power Dissipation Capacitance per Transceiver Outputs disabled		6.5	

SWITCHING CHARACTERISTICS<sup>(1)</sup>

Symbol	Parameter	V <sub>CCA</sub> = 5V ± 0.5V				Unit
		V <sub>CCB</sub> = 5V ± 0.5V		V <sub>CCB</sub> = 2.7V to 3.6V		
		Min.	Max.	Min.	Max.	
t <sub>PLH</sub>	Propagation Delay Ax to Bx	1	7.1	1	7	ns
t <sub>PHL</sub>		1	6	1	7	
t <sub>PLH</sub>	Propagation Delay Bx to Ax	1	6.8	1	6.2	ns
t <sub>PHL</sub>		1	6.1	1	5.3	
t <sub>PZL</sub>	Output Enable Time $\overline{OE}$ to Bx	1	8.2	1	10	ns
t <sub>PZH</sub>		1	8.1	1	10.2	
t <sub>PZL</sub>	Output Enable Time $\overline{OE}$ to Ax	1	9	1	9	ns
t <sub>PZH</sub>		1	8.3	1	8	
t <sub>PLZ</sub>	Output Disable Time $\overline{OE}$ to Ax	1	4.7	1	5.2	ns
t <sub>PHZ</sub>		1	4.9	1	5.2	
t <sub>PLZ</sub>	Output Disable Time $\overline{OE}$ to Bx	1	5.4	1	5.4	ns
t <sub>PHZ</sub>		1	6.3	1	7.4	

NOTE:

1. See TEST CIRCUITS AND WAVEFORMS. T<sub>A</sub> = - 40°C to + 85°C.

LOAD CIRCUIT AND VOLTAGE WAVEFORMS  
PARAMETER MEASUREMENT INFORMATION FOR A TO B

$V_{CCA} = 4.5V$  to  $5.5V$  and  $V_{CCB} = 2.7V$  to  $3.6V$

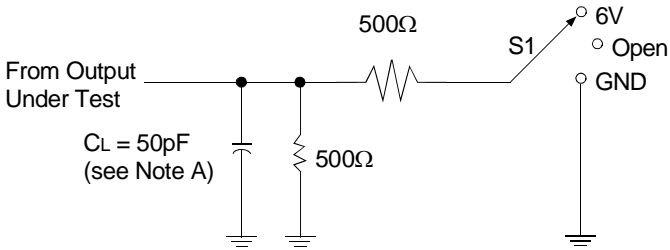

Load Circuit

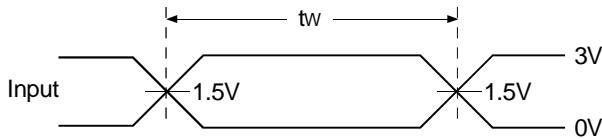

Voltage Waveforms Pulse Duration

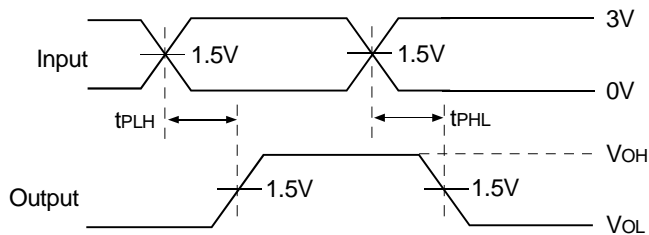

Voltage Waveforms Propagation Delay Times  
Noninverting Outputs

TEST CONDITIONS

TEST	S1
$t_{PLH}/t_{PHL}$	Open
$t_{PLZ}/t_{PZL}$	6V
$t_{PHZ}/t_{PZH}$	GND

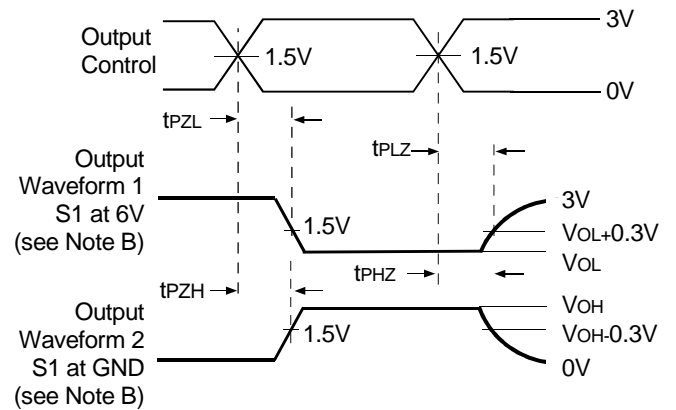

Voltage Waveforms Enable and Disable Times  
Low- and High-Level Enabling

NOTES:

- A.  $C_L$  includes probe and jig capacitance.
- B. Waveform 1 is for an output with internal conditions such that the output is LOW except when disabled by the output control.  
Waveform 2 is for an output with internal conditions such that the output is HIGH except when disabled by the output control.
- C. All input pulses are supplied by generators having the following characteristics:  $PRR \leq 10MHz$ ;  $Z_o = 50\Omega$ ;  $t_r \leq 2.5ns$ ;  $t_f \leq 2.5ns$ .
- D. The outputs are measured one at a time with one transition per measurement.

LOAD CIRCUIT AND VOLTAGE WAVEFORMS  
PARAMETER MEASUREMENT INFORMATION FOR A TO B

$V_{CCA} = 4.5V$  to  $5.5V$  and  $V_{CCB} = 3.6V$  to  $5.5V$

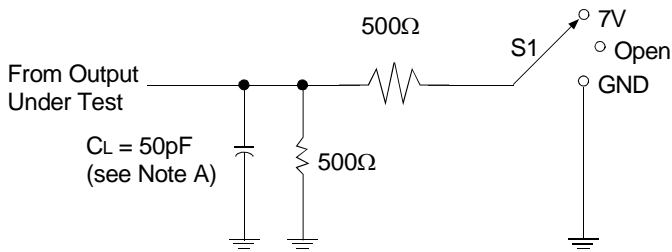

Load Circuit

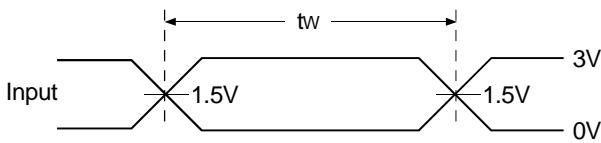

Voltage Waveforms Pulse Duration

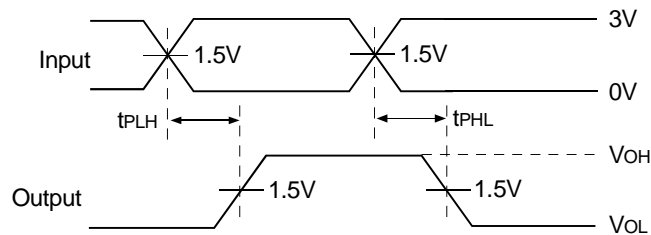

Voltage Waveforms Propagation Delay Times  
Noninverting Outputs

TEST CONDITIONS

TEST	S1
$t_{PLH}/t_{PHL}$	Open
$t_{PLZ}/t_{PZL}$	7V
$t_{PHZ}/t_{PZH}$	GND

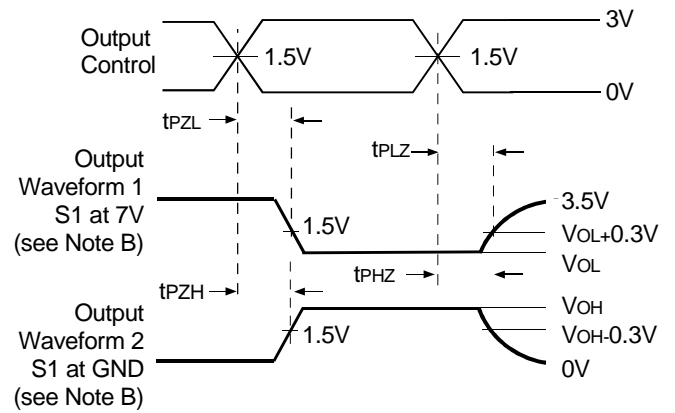

Voltage Waveforms Enable and Disable Times  
Low- and High-Level Enabling

NOTES:

- $C_L$  includes probe and jig capacitance.
- Waveform 1 is for an output with internal conditions such that the output is LOW except when disabled by the output control.  
Waveform 2 is for an output with internal conditions such that the output is HIGH except when disabled by the output control.
- All input pulses are supplied by generators having the following characteristics:  $PRR \leq 10MHz$ ;  $Z_o = 50\Omega$ ;  $t_r \leq 2.5ns$ ;  $t_f \leq 2.5ns$ .
- The outputs are measured one at a time with one transition per measurement.

LOAD CIRCUIT AND VOLTAGE WAVEFORMS  
PARAMETER MEASUREMENT INFORMATION FOR B TO A

$V_{CCA} = 4.5V$  to  $5.5V$  and  $V_{CCB} = 2.7V$  to  $3.6V$

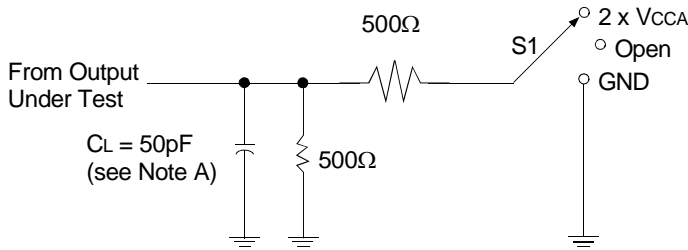

Load Circuit

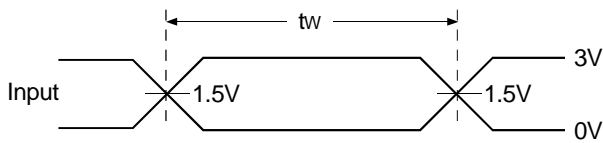

Voltage Waveforms Pulse Duration

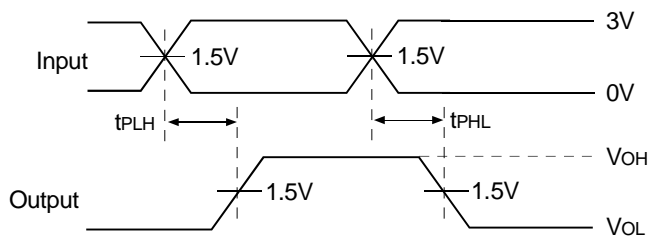

Voltage Waveforms Propagation Delay Times  
Noninverting Outputs

TEST CONDITIONS

TEST	S1
$t_{PLH}/t_{PHL}$	Open
$t_{PLZ}/t_{PZL}$	$2 \times V_{CCA}$
$t_{PHZ}/t_{PZH}$	GND

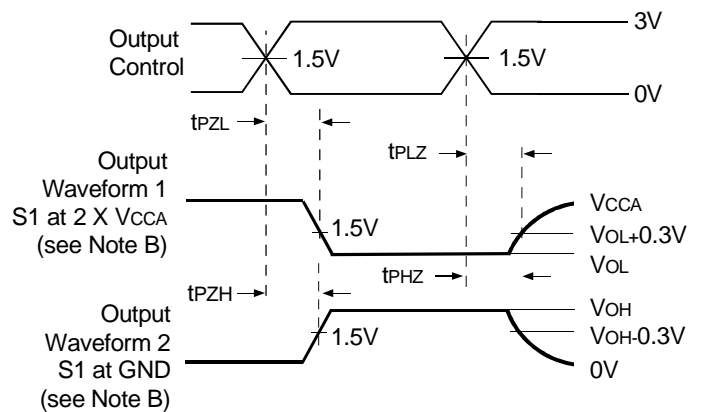

Voltage Waveforms Enable and Disable Times  
Low- and High-Level Enabling

NOTES:

- CL includes probe and jig capacitance.
- Waveform 1 is for an output with internal conditions such that the output is LOW except when disabled by the output control.  
Waveform 2 is for an output with internal conditions such that the output is HIGH except when disabled by the output control.
- All input pulses are supplied by generators having the following characteristics:  $PRR \leq 10MHz$ ;  $Z_o = 50\Omega$ ;  $t_r \leq 2.5ns$ ;  $t_f \leq 2.5ns$ .
- The outputs are measured one at a time with one transition per measurement.



## LOAD CIRCUIT AND VOLTAGE WAVEFORMS PARAMETER MEASUREMENT INFORMATION FOR B TO A

$V_{CCA} = 4.5V \text{ to } 5.5V$  and  $V_{CCB} = 3.6V \text{ to } 5.5V$

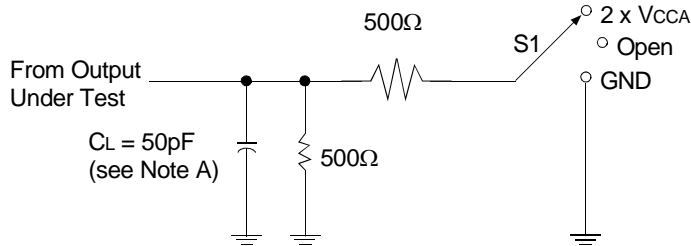

*Load Circuit*

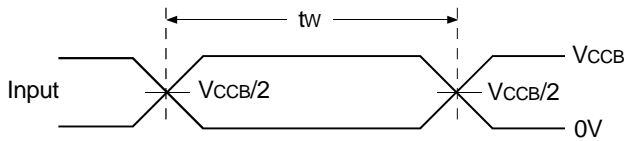

*Voltage Waveforms Pulse Duration*

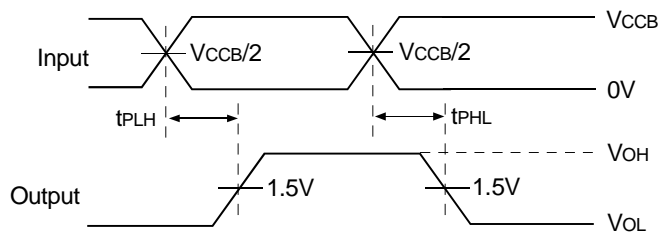

*Voltage Waveforms Propagation Delay Times  
Noninverting Outputs*

## TEST CONDITIONS

TEST	S1
$t_{PLH}/t_{PHL}$	Open
$t_{PLZ}/t_{PZL}$	$2 \times V_{CCA}$
$t_{PHZ}/t_{PZH}$	GND

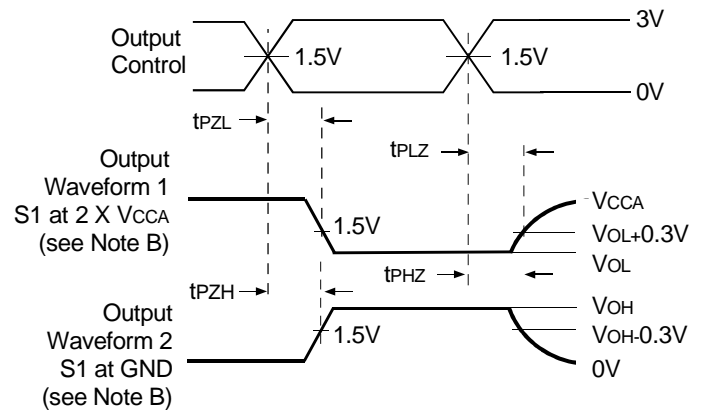

*Voltage Waveforms Enable and Disable Times  
Low- and High-Level Enabling*

### NOTES:

- CL includes probe and jig capacitance.
- Waveform 1 is for an output with internal conditions such that the output is LOW except when disabled by the output control.  
Waveform 2 is for an output with internal conditions such that the output is HIGH except when disabled by the output control.
- All input pulses are supplied by generators having the following characteristics:  $PRR \leq 10MHz$ ;  $Z_o = 50\Omega$ ;  $t_f \leq 2.5ns$ ;  $t_r \leq 2.5ns$ .
- The outputs are measured one at a time with one transition per measurement.

## ORDERING INFORMATION

IDT	XX	LVC	X	XXXX	XX	
Temp. Range			Bus-Hold	Device Type	Package	
						PY Shrink Small Outline Package
						Q Quarter Size Small Outline Package
						PG Thin Shrink Small Outline Package
						C4245A Octal Dual-Supply Bus Transceiver with Configurable Output Voltage and 3-State Outputs, ±24mA
						Blank No Bus-Hold
						74 -40°C to +85°C



**CORPORATE HEADQUARTERS**  
2975 Stender Way  
Santa Clara, CA 95054

**for SALES:**  
800-345-7015 or 408-727-6116  
fax: 408-492-8674  
www.idt.com

**for Tech Support:**  
logichelp@idt.com  
(408) 654-6459