

1.3 GHz PLL with I²C Bus for TV Tuner

Description

The U6207B is a single chip frequency synthesizer with I²C bus control. This IC contains a high frequency prescaler which can be switched off. The maximum input frequency at switched off prescaler is 220 MHz, so that

special channels, e.g. weather forecast channels, can be received. 3 open collector switching outputs are available.

Features

- 1.3 GHz divide-by-8 prescaler integrated (can be bypassed)
- 15 bit counter accepts input frequencies up to 220 MHz
- μ P-controlled by I²C bus
- 3 switching outputs (open collector)
- 4 addresses selectable at Pin 7 for multituner application
- 62.5 kHz (-1.3 GHz)/ 7.8125 kHz (-220 MHz) tuning steps
- Electrostatic protection according to MIL-STD 883
- SO14 package

Block Diagram

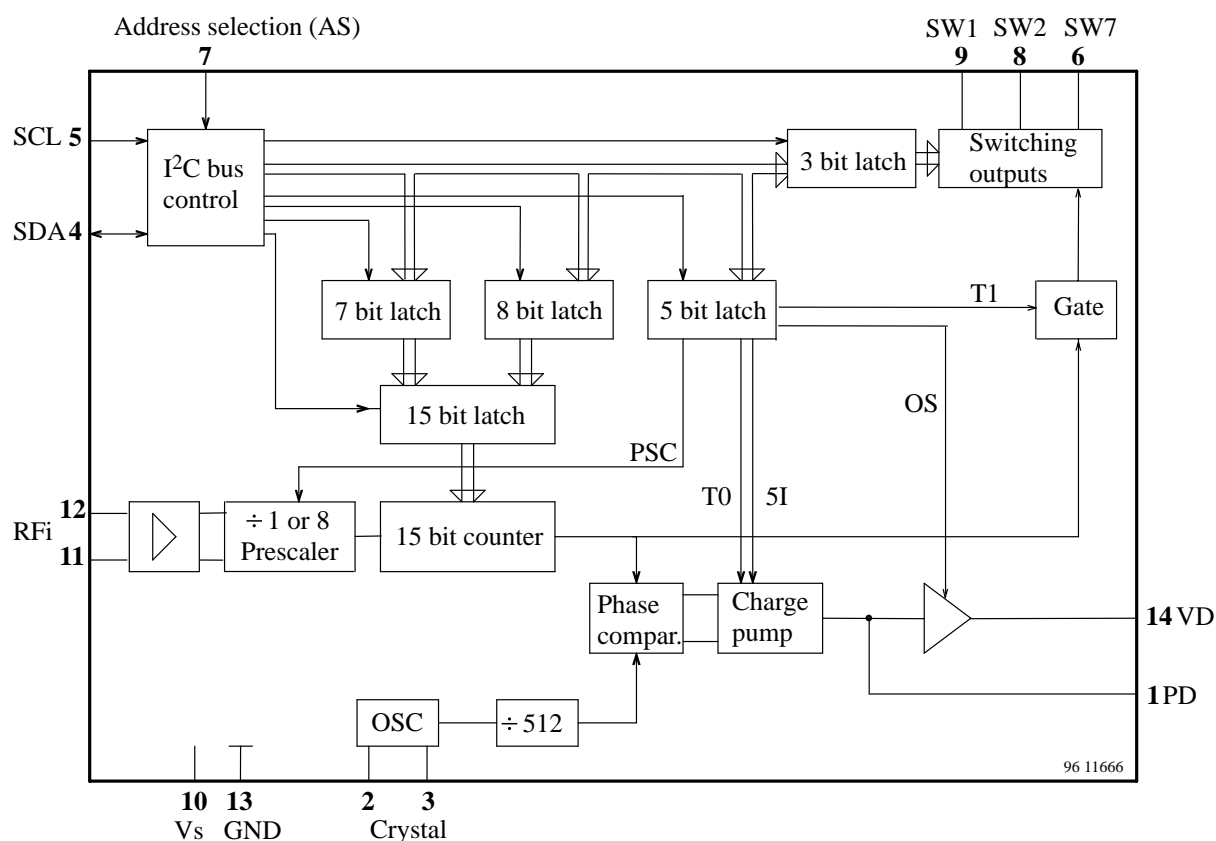
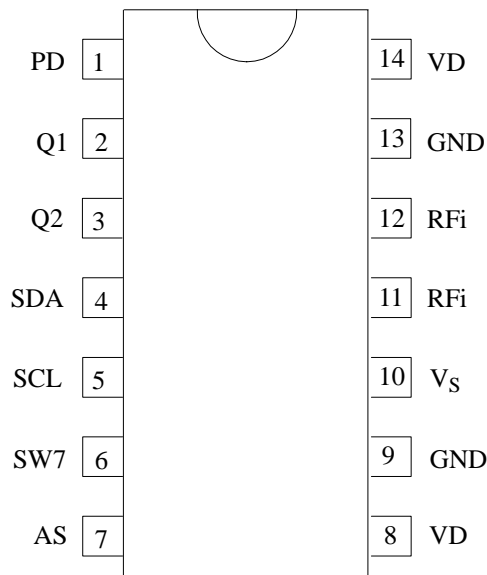

Figure 1.

Ordering Information

Extended Type Number	Package	Remarks
U6207B-FPG3	SO14 plastic package	Taped and reeled

Pin Description



95 10699

Figure 2.

Pin	Symbol	Function
1	PD	Charge pump output
2	Q1	Crystal
3	Q2	Crystal
4	SDA	Data in/output
5	SCL	Clock
6	SW7	Switching output (open collector)
7	AS	Address select
8	SW2	Switching output (open collector)
9	SW1	Switching output (open collector)
10	V _S	Supply voltage
11	RFi	RF input
12	RFi	RF input
13	GND	Ground
14	VD	Active filter output

Absolute Maximum Ratings

All voltages are referred to GND (Pin 13).

Parameters	Symbol	Min.	Typ.	Max.	Unit
Supply voltage	Pin 10 V _S	-0.3		6	V
RF input voltage	Pin 11, 12 RFi	-0.3		V _S	V
Bus input/output voltage	Pin 4 VSDA	-0.3		V _S	V
	Pin 5 VSCL	-0.3		V _S	V
SDA output current (open collector)	Pin 4 ISDA	-1		5	mA
Address select voltage	Pin 7 VAS	-0.3		V _S	V
Current switching outputs (open collector)	Pin 9, 8, 6 SW 1,2,7	-1		15	mA
Junction temperature	T _j	-40		125	°C
Storage temperature	T _{stg}	-40		125	°C

Operating Range

All voltages are referred to GND (Pin 13).

Parameters	Test Conditions / Pins	Symbol	Min.	Typ.	Max.	Unit
Supply voltage	Pin 10	V _S	4.5		5.5	V
Ambient temperature		T _{amb}	0		70	°C
Input frequency	PSC = 1 Pin 11, 12	RFi	64		1300	MHz
Input frequency	PSC = 0 Pin 11, 12	RFi	1		220	MHz
Prog. divider		SF	256		32767	

Thermal Resistance

Parameter	Symbol	Test Condition	Value	Unit
Junction ambient	R _{thJA}	Soldered to PCB	110	K/W

Electrical Characteristics

Test conditions (unless otherwise specified) $V_S = 5\text{ V}$, $T_{\text{amb}} = 25^\circ\text{C}$

Parameters	Test Conditions / Pins	Symbol	Min.	Typ.	Max.	Unit
Supply current	Pin 10 SW 1, 2, 7 = 0; PSC = 1	I_S	32	42	52	mA
	SW 1, 2, 7 = 0; PSC = 0	I_S	22	28	35	mA
Input sensitivity						
$f_i = 80 - 1000\text{ MHz}$	PSC = 1 Pin 11	$V_i^{1)}$			10	mV
$f_i = 1300\text{ MHz}$	PSC = 1 Pin 11	$V_i^{1)}$			40	mV
$f_i = 10 - 220\text{ MHz}$	PSC = 0 Pin 11	$V_i^{1)}$			10	mV
Maximum input signal	PSC = 0 / 1 Pin 11	$V_{\text{imax}}^{1)}$	315			mV
Open collector switching outputs (SW 1,2,7) Pin 9,8,6						
Reserve current	$V_H = 13.5\text{ V}$	IRH			10	μA
Saturation voltage	$I_L = 10\text{ mA}$	VSL ²⁾			0.5	V
Phase detector output						
Charge pump current "H"	$5I = 1$, $V_{PD} = 2\text{ V}$, Pin 1	IPDH		± 180		μA
Charge pump current "L"	$5I = 0$, $V_{DP} = 2\text{ V}$, Pin 1	IPDL		± 50		μA
Charge pump leakage current	$T_0 = 0$, $V_{PD} = 2\text{ V}$, Pin 1	IPDTRI		± 5		nA
Bus inputs (SDA,SCL)						
Input voltage	Pin 4, 5 Pin 4, 5	V_i "H"	3		5.5	V
		V_i "L"			1.5	V
Input current	V_{SCL} "H" = V_S , V_{SCL} "L" = 0 V, Pin 4, 5	i_i "H"			10	μA
		i_i "L"	-20			μA
Output voltage SDA (open collector)	I_{SDA} "L" = 2 mA, Pin 4	V_{SDA} "L"			0.4	V
Address selection (AS)						
Input current	V_{AS} "H" = V_S Pin 7	i_{iAS} "H"			10	μA
	V_{AS} "L" = 0 V Pin 7	i_{iAS} "L"	-100			μA
Bus timing						
Rise time SDA, SCL		t_R			15	μs
Fall time SDA, SCL		t_F			15	μs
Clock frequency SCL		f_{SCL}	0		100	kHz
Clock "H" Pulse		t_{HIGH}	4			μs
Clock "L" Pulse		t_{LOW}	4			μs
Hold time start		t_{HSTA}	4			μs
Set-up time stop		t_{SSTO}	4			μs
Set-up time data		t_{SDAT}	0.3			μs
Hold time data		t_{HDAT}	0			μs

1) RMS-voltage calculated from the measured available power on 50 Ω .

2) Tested with one switch active.

I²C Bus Description

Data Formats

Description	Data Format								
	MSB					LSB			
Address byte	1	1	0	0	0	AS1	AS2	0	A
Progr. divider byte 1	0	n14	n13	n12	n11	n10	n9	n8	A
Progr. divider byte 2	n7	n6	n5	n4	n3	n2	n1	n0	A
Control byte 1	1	5I	T1	T0	X	X	PSC	OS	A
Control byte 2	SW7	X	X	X	X	SW2	SW1	X	A

A = Acknowledge; X = not used; Unused bits of controlbyte 2 should be 0 for lowest power consumption.

n0 ... n14:	Scaling factor (SF)	SF = 16384*n14 + 8192*n13 + ... +2*n1 + n0
PSC	Prescaler on/off	PSC = 1: prescaler on (PSF = 8) PSC = 0: prescaler off (PSF = 1)
T0, T1	Testmode selection	T1 = 1: divider test mode on T1 = 0: divider test mode off T0 = 1: charge pump disable T0 = 0: charge pump enable
SW 1, 2, 7	Switching outputs	SW1, SW2, SW7 = 1: open collector active
5I	Charge pump current switch	5I = 1: high current 5I = 0: low current
OS	Output switch	OS = 1: varicap drive disable OS = 0: varicap drive enable

AS1, AS2 Address selection pin 7

AS1	AS2	Address	Dec. Value	Voltage at pin7
0	1	1	194	open
0	0	2	192	0 to 10% Vs
1	0	3	196	40 to 60% Vs
1	1	4	198	90 to 100% Vs

Oscillator Frequency Calculation

$$f_{osc} = f_{ref} * SF * PSF$$

f_{osc} Locked oscillator frequency

f_{ref} Reference frequency 4 MHz / 512 = 7.8125 kHz

SF Scaling factor of programmable 15-bit-divider

PSF Scaling factor of prescaler

I²C Bus Description (continued)

Pulse Diagram

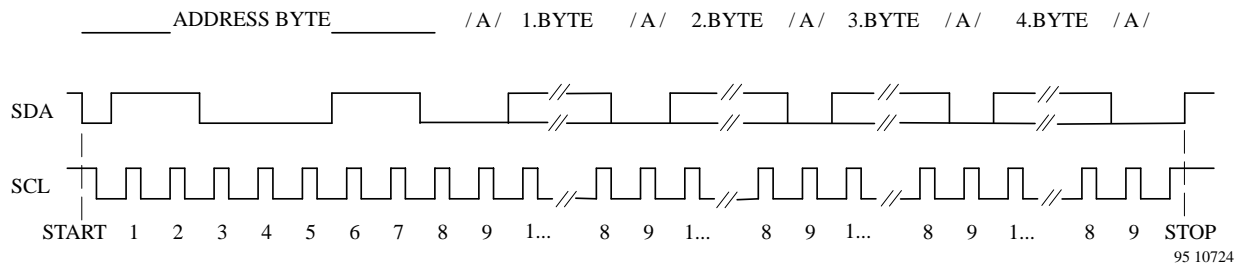

Figure 3.

Bus Timing

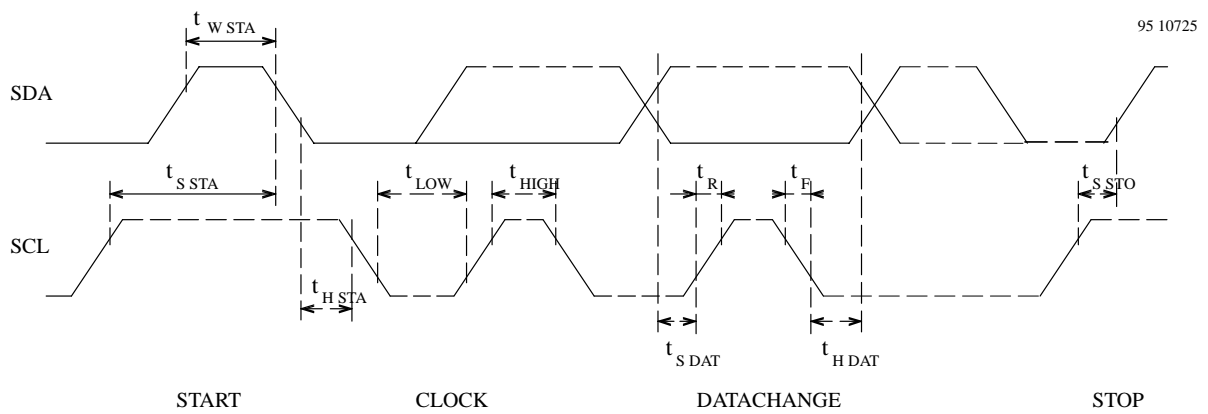

Figure 4.

Typical Prescaler Input Sensitivity (PSC = 1)

V_i (mV RMS on 50Ω)

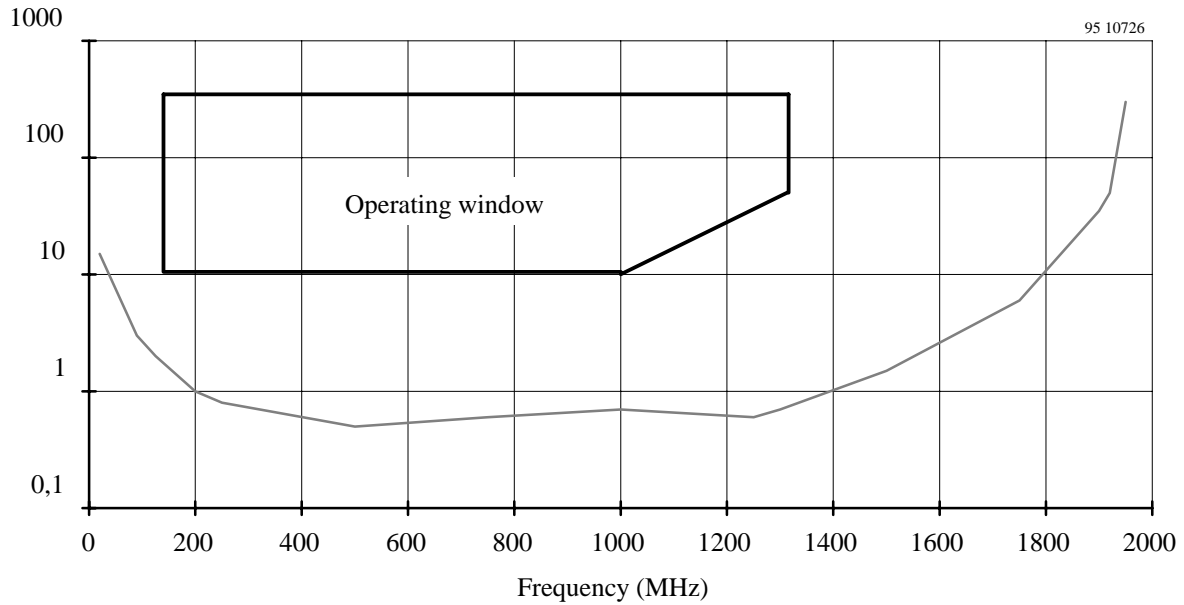

Figure 5.

Typical Prescaler Input Sensitivity (PSC = 0)

V_i (mV RMS on 50Ω)

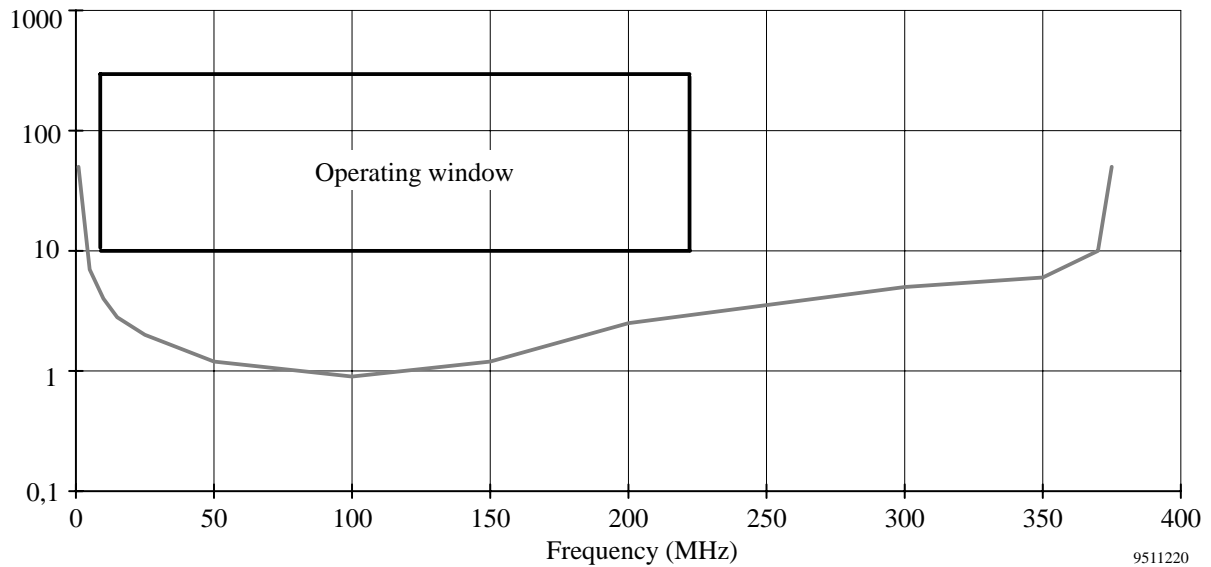

Figure 6.

Application Circuit

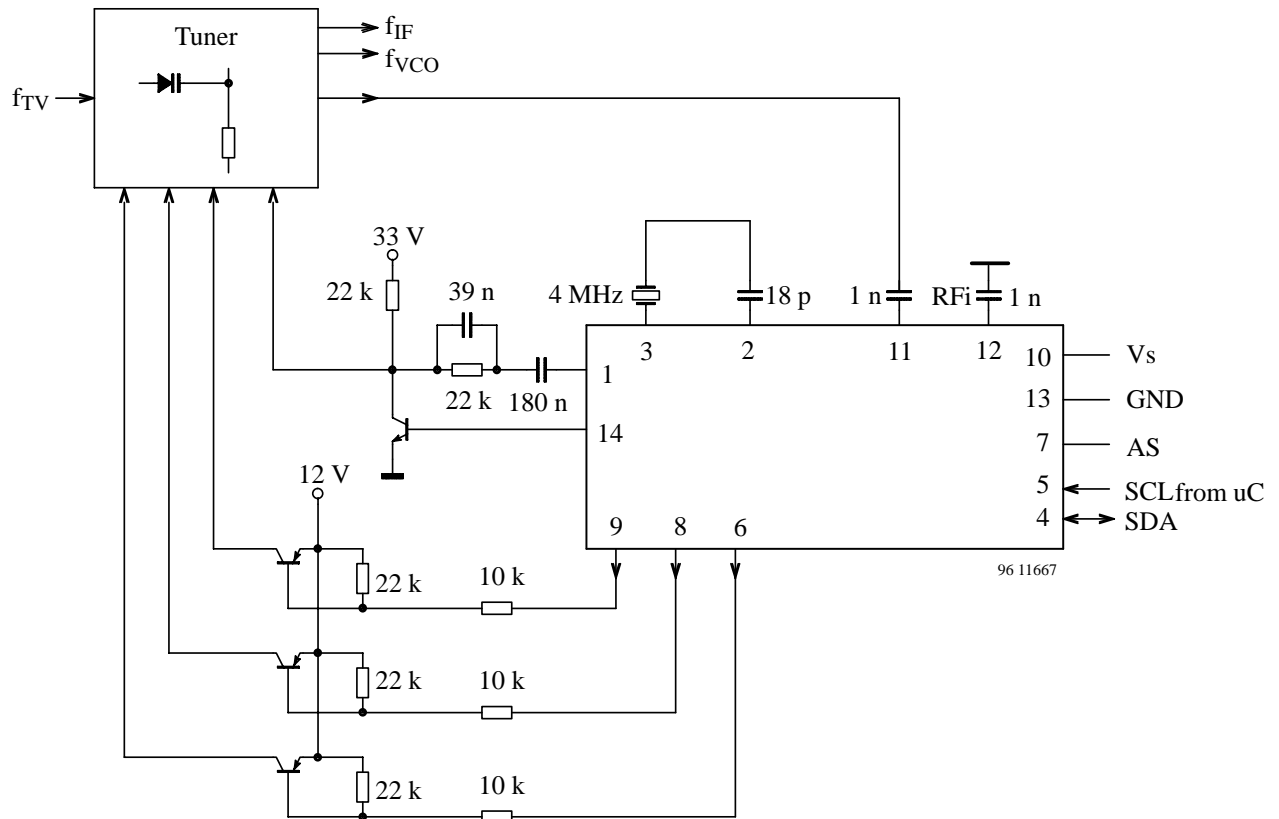
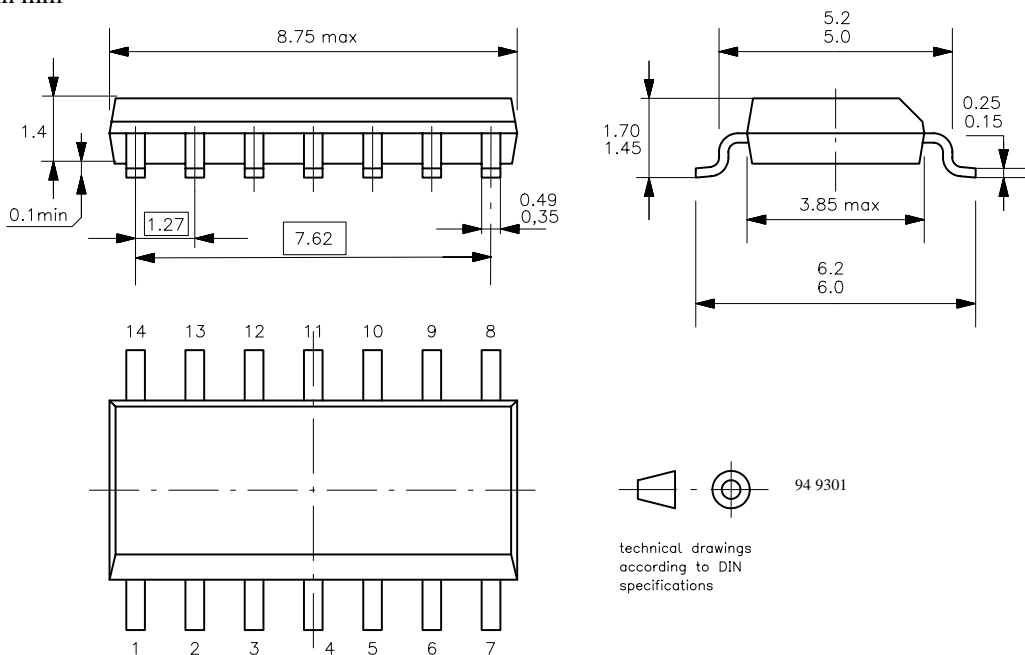

Figure 7.

Package Dimensions

Small outline plastic package, 14 pin-SO 14
Dimensions in mm



Ozone Depleting Substances Policy Statement

It is the policy of **TEMIC Semiconductor GmbH** to

1. Meet all present and future national and international statutory requirements.
2. Regularly and continuously improve the performance of our products, processes, distribution and operating systems with respect to their impact on the health and safety of our employees and the public, as well as their impact on the environment.

It is particular concern to control or eliminate releases of those substances into the atmosphere which are known as ozone depleting substances (ODSs).

The Montreal Protocol (1987) and its London Amendments (1990) intend to severely restrict the use of ODSs and forbid their use within the next ten years. Various national and international initiatives are pressing for an earlier ban on these substances.

TEMIC Semiconductor GmbH has been able to use its policy of continuous improvements to eliminate the use of ODSs listed in the following documents.

1. Annex A, B and list of transitional substances of the Montreal Protocol and the London Amendments respectively
2. Class I and II ozone depleting substances in the Clean Air Act Amendments of 1990 by the Environmental Protection Agency (EPA) in the USA
3. Council Decision 88/540/EEC and 91/690/EEC Annex A, B and C (transitional substances) respectively.

TEMIC Semiconductor GmbH can certify that our semiconductors are not manufactured with ozone depleting substances and do not contain such substances.

We reserve the right to make changes to improve technical design and may do so without further notice.

Parameters can vary in different applications. All operating parameters must be validated for each customer application by the customer. Should the buyer use TEMIC Semiconductors products for any unintended or unauthorized application, the buyer shall indemnify TEMIC Semiconductors against all claims, costs, damages, and expenses, arising out of, directly or indirectly, any claim of personal damage, injury or death associated with such unintended or unauthorized use.

TEMIC Semiconductor GmbH, P.O.B. 3535, D-74025 Heilbronn, Germany
Telephone: 49 (0)7131 67 2594, Fax number: 49 (0)7131 67 2423