



LINEAR

TECHNOLOGY

325MHz, 140V/ μ s Rail-to-Rail Input and Output Low Distortion, Low Noise Precision Op Amp

June 2000

FEATURES

- Gain Bandwidth Product: 325MHz
- Slew Rate: 140V/ μ s
- Wide Supply Range: 2.5V to 12V
- Large Output Current: 85mA
- Low Distortion, 5MHz: -80 dBc
- Low Voltage Noise: 3.5nV/ $\sqrt{\text{Hz}}$
- Input Common Mode Range Includes Both Rails
- Output Swings Rail-to-Rail
- Input Offset Voltage (Rail-to-Rail): 550 μ V Max
- Common Mode Rejection: 106dB Typ
- Power Supply Rejection: 105dB Typ
- Open-Loop Gain: 300V/mV Typ
- Power Down Pin
- SO-8 Package
- Operating Temperature Range -40°C to 85°C

APPLICATIONS

- Active Filters
- Rail-to-Rail Buffer Amplifiers
- Driving A/D Converters
- Low Voltage Signal Processing
- Video Line Driver

DESCRIPTION

The LT[®]1806 is a rail-to-rail input and output op amp that features a 325MHz gain bandwidth product, a 140V/ μ s slew rate and a 85mA output current to fit the need for low voltage, high performance signal conditioning systems.

The LT1806 has a very low distortion of -80 dBc at 5MHz, a low input referred noise voltage of 3.5nV/ $\sqrt{\text{Hz}}$ and a maximum offset voltage of 550 μ V that allows it to be used in high performance data acquisition systems.

The LT1806 has an input range that includes both supply rails and an output that swings within 20mV of either supply rail to maximize the signal dynamic range in low supply applications.

The LT1806 maintains its performance for supplies from 2.5V to 12V and is specified at 3V, 5V and ± 5 V supplies. The inputs can be driven beyond the supplies without damage or phase reversal of the output.

The LT1806 is available in an 8-pin SO package with the standard op amp pinout. This device can be used as a plug-in replacement for many op amps to improve input/output range and performance.

LT, LTC and LT are registered trademarks of Linear Technology Corporation.

TYPICAL APPLICATION

3V Single Supply Video Line Driver

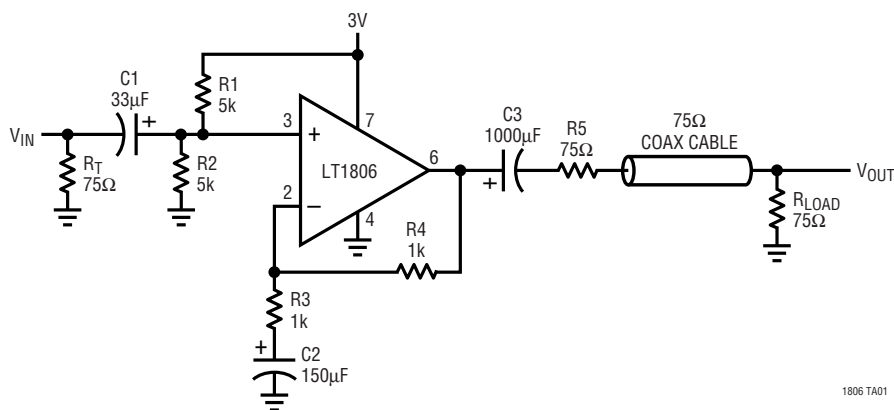

1806 TA01

ABSOLUTE MAXIMUM RATINGS

(Note 1)

Total Supply Voltage (V^+ to V^-)	12.6V
Input Voltage (Note 2)	$\pm V_S$
Input Current (Note 2)	$\pm 10\text{mA}$
Output Short-Circuit Duration (Note 3)	Indefinite
Operating Temperature Range (Note 4) ..	-40°C to 85°C
Specified Temperature Range (Note 5) ...	-40°C to 85°C
Junction Temperature	150°C
Storage Temperature Range	-65°C to 150°C
Lead Temperature (Soldering, 10 sec)	300°C

PACKAGE/ORDER INFORMATION

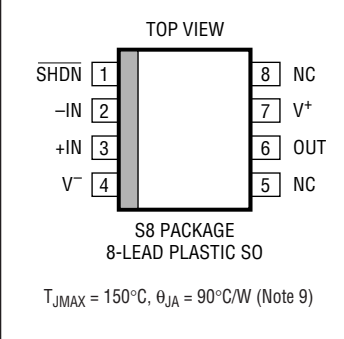
	ORDER PART NUMBER
	LT1806CS8 LT1806IS8
	S8 PART MARKING
	1806 1806I

Consult factory for Military grade parts.

ELECTRICAL CHARACTERISTICS

$T_A = 25^\circ\text{C}$. $V_S = 5\text{V}$, 0V ; $V_S = 3\text{V}$, 0V ; $V_{\text{SHDN}} = \text{open}$; $V_{\text{CM}} = V_{\text{OUT}} = \text{half supply unless otherwise noted}$.

SYMBOL	PARAMETER	CONDITIONS	MIN	TYP	MAX	UNITS
V_{OS}	Input Offset Voltage	$V_{\text{CM}} = V^+$ $V_{\text{CM}} = V^-$		100	550	μV μV
ΔV_{OS}	Input Offset Voltage Shift	$V_{\text{CM}} = V^-$ to V^+		50	500	μV
I_B	Input Bias Current	$V_{\text{CM}} = V^+$ $V_{\text{CM}} = V^-$	-13	1 -5	4	μA μA
ΔI_B	Input Bias Current Shift	$V_{\text{CM}} = V^-$ to V^+		6	17	μA
I_{OS}	Input Offset Current	$V_{\text{CM}} = V^+$ $V_{\text{CM}} = V^-$		0.03 0.05	0.6 1.5	μA μA
ΔI_{OS}	Input Offset Current Shift	$V_{\text{CM}} = V^-$ to V^+		0.08	2.1	μA
	Input Noise Voltage	0.1Hz to 10Hz		40		$\text{nV}_{\text{p-p}}$
e_n	Input Noise Voltage Density	$f = 10\text{kHz}$		3.5		$\text{nV}/\sqrt{\text{Hz}}$
i_n	Input Noise Current Density	$f = 10\text{kHz}$		4		$\text{pA}/\sqrt{\text{Hz}}$
C_{IN}	Input Capacitance			2		pF
A_{VOL}	Large Signal Voltage Gain	$V_S = 5\text{V}$, $V_O = 0.5\text{V}$ to 4.5V , $R_L = 1\text{k}$ $V_S = 5\text{V}$, $V_O = 1\text{V}$ to 4V , $R_L = 100$ $V_S = 3\text{V}$, $V_O = 0.5\text{V}$ to 2.5V , $R_L = 1\text{k}$	90 10 75	220 22 150		V/mV V/mV V/mV
CMRR	Common Mode Rejection Ratio	$V_S = 5\text{V}$, $V_{\text{CM}} = V^-$ to V^+ $V_S = 3\text{V}$, $V_{\text{CM}} = V^-$ to V^+	80 75	100 95		dB dB
	Input Common Mode Range		V^-		V^+	V
PSRR	Power Supply Rejection Ratio	$V_S = 2.5\text{V}$ to 10V , $V_{\text{CM}} = 0\text{V}$	91	105		dB
	Minimum Supply Voltage (Note 6)			2.3	2.5	V
V_{OL}	Output Voltage Swing LOW (Note 7)	No Load $I_{\text{SINK}} = 5\text{mA}$ $I_{\text{SINK}} = 25\text{mA}$		6 45 170	35 130 400	mV mV mV
V_{OH}	Output Voltage Swing HIGH (Note 7)	No Load $I_{\text{SOURCE}} = 5\text{mA}$ $I_{\text{SOURCE}} = 25\text{mA}$		12 85 350	50 180 700	mV mV mV
I_{SC}	Short-Circuit Current	$V_S = 5\text{V}$ $V_S = 3\text{V}$	± 35 ± 30	± 70 ± 60		mA mA
I_S	Supply Current			9	13	mA

ELECTRICAL CHARACTERISTICS

T_A = 25°C. V_S = 5V, 0V; V_S = 3V, 0V; V_{SHDN} = open; V_{CM} = V_{OUT} = half supply unless otherwise noted.

SYMBOL	PARAMETER	CONDITIONS	MIN	TYP	MAX	UNITS
	Disable Supply Current	V _S = 5V, V _{SHDN} = 0V V _S = 3V, V _{SHDN} = 0V		0.30 0.16	0.9 0.7	mA mA
GBW	Gain Bandwidth Product	Frequency = 2MHz		325		MHz
SR	Slew Rate	V _S = 5V, A _V = -1, R _L = 1k, V _O = 4V _{P-P}		130		V/μs
THD	Total Harmonic Distortion	V _S = 5V, A _V = 1, R _L = 1k, V _O = 2V _{P-P} , f _C = 5MHz		-78		dB
t _S	Settling Time	0.01%, V _S = 5V, V _{STEP} = 2V, A _V = 1, R _L = 1k		60		ns
ΔG	Differential Gain (NTSC)	V _S = 5V, A _V = 2, R _L = 150		0.015		%
Δθ	Differential Phase (NTSC)	V _S = 5V, A _V = 2, R _L = 150		0.05		Deg

The ● denotes specifications which apply over the 0°C < T_A < 70°C temperature range. V_S = 5V, 0V; V_S = 3V, 0V; V_{SHDN} = open; V_{CM} = V_{OUT} = half supply unless otherwise noted.

SYMBOL	PARAMETER	CONDITIONS	MIN	TYP	MAX	UNITS
V _{OS}	Input Offset Voltage	V _{CM} = V ⁺ V _{CM} = V ⁻	● ●	200 200	700 700	μV μV
V _{OS} TC	Input Offset Voltage Drift (Note 8)	V _{CM} = V ⁺ V _{CM} = V ⁻	● ●	1.5 1.5	5 5	μV/°C μV/°C
ΔV _{OS}	Input Offset Voltage Shift	V _{CM} = V ⁻ to V ⁺	●	100	700	μV
I _B	Input Bias Current	V _{CM} = V ⁺ - 0.1V V _{CM} = V ⁻ + 0.2V	● ●	1 -14	5	μA μA
ΔI _B	Input Bias Current Shift	V _{CM} = V ⁻ + 0.2V to V ⁺ - 0.1V	●	6	19	μA
I _{OS}	Input Offset Current	V _{CM} = V ⁺ - 0.1V V _{CM} = V ⁻ + 0.2V	● ●	0.03 0.05	0.75 1.8	μA μA
ΔI _{OS}	Input Offset Current Shift	V _{CM} = V ⁻ + 0.2V to V ⁺ - 0.1V	●	0.08	2.55	μA
A _{VOL}	Large Signal Voltage Gain	V _S = 5V, V _O = 0.5V to 4.5V, R _L = 1kΩ V _S = 5V, V _O = 1V to 4V, R _L = 100Ω V _S = 3V, V _O = 0.5V to 2.5V, R _L = 1kΩ	● ● ●	75 9 65	175 20 140	V/mV V/mV V/mV
CMRR	Common Mode Rejection Ratio	V _S = 5V, V _{CM} = V ⁻ to V ⁺ V _S = 3V, V _{CM} = V ⁻ to V ⁺	● ●	77 72	94 89	dB dB
	Input Common Mode Range		●	V ⁻	V ⁺	V
PSRR	Power Supply Rejection Ratio	V _S = 2.5V to 10V, V _{CM} = 0V	●	89	105	dB
	Minimum Supply Voltage (Note 6)		●	2.3	2.5	V
V _{OL}	Output Voltage Swing LOW (Note 7)	No Load I _{SINK} = 5mA I _{SINK} = 25mA	● ● ●	8 50 180	60 150 450	mV mV mV
V _{OH}	Output Voltage Swing HIGH (Note 7)	No Load I _{SOURCE} = 5mA I _{SOURCE} = 25mA	● ● ●	30 110 370	80 220 750	mV mV mV
I _{SC}	Short-Circuit Current	V _S = 5V V _S = 3V	● ●	±30 ±25	±65 ±55	mA mA
I _S	Supply Current		●	10	14	mA
	Disable Supply Current	V _S = 5V, V _{SHDN} = 0V V _S = 3V, V _{SHDN} = 0V	● ●	0.3 0.18	1.1 0.9	mA mA
GBW	Gain Bandwidth Product	Frequency = 2MHz	●	300		MHz
SR	Slew Rate	V _S = 5V, A _V = -1, R _L = 1k, V _O = 4V _{P-P}	●	100		V/μs

ELECTRICAL CHARACTERISTICS The ● denotes the specifications which apply over the $-40^{\circ}\text{C} < T_A < 85^{\circ}\text{C}$ temperature range. $V_S = 5\text{V}, 0\text{V}; V_S = 3\text{V}, 0\text{V}; V_{\text{SHDN}} = \text{open}; V_{\text{CM}} = V_{\text{OUT}} = \text{half supply unless otherwise noted. (Note 5)}$

SYMBOL	PARAMETER	CONDITIONS		MIN	TYP	MAX	UNITS
V_{OS}	Input Offset Voltage	$V_{\text{CM}} = V^+$	●		200	800	μV
		$V_{\text{CM}} = V^-$	●		200	800	μV
$V_{\text{OS TC}}$	Input Offset Voltage Drift (Note 8)	$V_{\text{CM}} = V^+$	●		1.5	5	$\mu\text{V}/^{\circ}\text{C}$
		$V_{\text{CM}} = V^-$	●		1.5	5	$\mu\text{V}/^{\circ}\text{C}$
ΔV_{OS}	Input Offset Voltage Shift	$V_{\text{CM}} = V^-$	●		100	800	μV
I_{B}	Input Bias Current	$V_{\text{CM}} = V^+ - 0.1\text{V}$	●		1	6	μA
		$V_{\text{CM}} = V^- + 0.2\text{V}$	●	-16	-5		μA
ΔI_{B}	Input Bias Current Shift	$V_{\text{CM}} = V^- + 0.2\text{V to } V^+ - 0.1\text{V}$	●		6	22	μA
I_{OS}	Input Offset Current	$V_{\text{CM}} = V^+ - 0.1\text{V}$	●		0.02	0.9	μA
		$V_{\text{CM}} = V^- + 0.2\text{V}$	●		0.05	2.1	μA
ΔI_{OS}	Input Offset Current Shift	$V_{\text{CM}} = V^- + 0.2\text{V to } V^+ - 0.1\text{V}$	●		0.07	3	μA
A_{VOL}	Large Signal Voltage Gain	$V_S = 5\text{V}, V_O = 0.5\text{V to } 4.5\text{V}, R_L = 1\text{k}\Omega$	●	60	140		V/mV
		$V_S = 5\text{V}, V_O = 1\text{V to } 4\text{V}, R_L = 100\Omega$	●	7	16		V/mV
		$V_S = 3\text{V}, V_O = 0.5\text{V to } 2.5\text{V}, R_L = 1\text{k}\Omega$	●	50	100		V/mV
CMRR	Common Mode Rejection Ratio	$V_S = 5\text{V}, V_{\text{CM}} = V^- \text{ to } V^+$	●	75	94		dB
		$V_S = 3\text{V}, V_{\text{CM}} = V^- \text{ to } V^+$	●	71	89		dB
	Input Common Mode Range		●	V^-		V^+	V
PSRR	Power Supply Rejection Ratio	$V_S = 2.5\text{V to } 10\text{V}, V_{\text{CM}} = 0\text{V}$	●	87	105		dB
		Minimum Supply Voltage (Note 6)	●		2.3	2.5	V
V_{OL}	Output Voltage Swing LOW (Note 7)	No Load	●		10	70	mV
		$I_{\text{SINK}} = 5\text{mA}$	●		50	160	mV
		$I_{\text{SINK}} = 20\text{mA}$	●		170	400	mV
V_{OH}	Output Voltage Swing HIGH (Note 7)	No Load	●		300	100	mV
		$I_{\text{SOURCE}} = 5\text{mA}$	●		110	240	mV
		$I_{\text{SOURCE}} = 20\text{mA}$	●		310	650	mV
I_{SC}	Short-Circuit Current	$V_S = 5\text{V}$	●	± 22	± 45		mA
		$V_S = 3\text{V}$	●	± 20	± 40		mA
I_{S}	Supply Current		●		11	16	mA
		Disable Supply Current	●		0.4	1.2	mA
		$V_S = 5\text{V}, V_{\text{SHDN}} = 0\text{V}$	●		0.4	1.2	mA
		$V_S = 3\text{V}, V_{\text{SHDN}} = 0\text{V}$	●		0.2	1	mA
GBW	Gain Bandwidth Product	Frequency = 2MHz	●		250		MHz
SR	Slew Rate	$V_S = 5\text{V}, A_V = -1, R_L = 1\text{k}, V_O = 4\text{V}_{\text{P-P}}$	●		80		$\text{V}/\mu\text{s}$

ELECTRICAL CHARACTERISTICS

$T_A = 25^\circ\text{C}$. $V_S = \pm 5\text{V}$, $V_{\text{SHDN}} = \text{open}$; $V_{\text{CM}} = 0\text{V}$, $V_{\text{OUT}} = 0\text{V}$ unless otherwise noted.

SYMBOL	PARAMETER	CONDITIONS	MIN	TYP	MAX	UNITS
V_{OS}	Input Offset Voltage	$V_{\text{CM}} = V^+$		100	650	μV
		$V_{\text{CM}} = V^-$		100	650	μV
ΔV_{OS}	Input Offset Voltage Shift	$V_{\text{CM}} = V^- \text{ to } V^+$		50	600	μV
I_{B}	Input Bias Current	$V_{\text{CM}} = V^+$		1	5	μA
		$V_{\text{CM}} = V^-$	-14	-5		μA
ΔI_{B}	Input Bias Current Shift	$V_{\text{CM}} = V^- \text{ to } V^+$		6	19	μA
I_{OS}	Input Offset Current	$V_{\text{CM}} = V^+$		0.03	0.7	μA
		$V_{\text{CM}} = V^-$		0.04	1.6	μA
ΔI_{OS}	Input Offset Current Shift	$V_{\text{CM}} = V^- \text{ to } V^+$		0.07	2.3	μA
	Input Noise Voltage	0.1Hz to 10Hz		40		nV _{p-p}
e_{n}	Input Noise Voltage Density	f = 10kHz		3.5		nV/ $\sqrt{\text{Hz}}$
i_{n}	Input Noise Current Density	f = 10kHz		5		pA/ $\sqrt{\text{Hz}}$
C_{IN}	Input Capacitance	f = 100kHz		2		pF
A_{VOL}	Large Signal Voltage Gain	$V_{\text{O}} = -4\text{V to } 4\text{V}$, $R_{\text{L}} = 1\text{k}\Omega$	120	300		V/mV
		$V_{\text{O}} = -2.5\text{V to } 2.5\text{V}$, $R_{\text{L}} = 100\Omega$	12	27		V/mV
CMRR	Common Mode Rejection Ratio	$V_{\text{CM}} = V^- \text{ to } V^+$	84	106		dB
	Input Common Mode Range		V^-		V^+	V
PSRR	Power Supply Rejection Ratio	$V^+ = 2.5\text{V to } 10\text{V}$, $V_{\text{CM}} = 0\text{V}$	91	105		dB
V_{OL}	Output Voltage Swing LOW (Note 7)	No Load		10	60	mV
		$I_{\text{SINK}} = 5\text{mA}$		45	140	mV
		$I_{\text{SINK}} = 25\text{mA}$		180	450	mV
V_{OH}	Output Voltage Swing HIGH (Note 7)	No Load		20	70	mV
		$I_{\text{SOURCE}} = 5\text{mA}$		90	200	mV
		$I_{\text{SOURCE}} = 25\text{mA}$		360	700	mV
I_{SC}	Short-Circuit Current		± 40	± 85		mA
I_{S}	Supply Current			11	16	mA
	Disable Supply Current	$V_{\text{SHDN}} = 0\text{V}$		0.4	1.2	mA
GBW	Gain Bandwidth Product	Frequency = 2MHz	180	325		MHz
SR	Slew Rate	$A_{\text{V}} = -1$, $R_{\text{L}} = 1\text{k}$, $V_{\text{O}} = \pm 4\text{V}$, Measure at $V_{\text{O}} = \pm 2\text{V}$	70	140		V/ μs
THD	Total Harmonic Distortion	$A_{\text{V}} = 1$, $R_{\text{L}} = 1\text{k}$, $V_{\text{O}} = 2V_{\text{P-P}}$, $f_{\text{C}} = 5\text{MHz}$		-80		dB
t_{S}	Settling Time	0.01%, $V_{\text{STEP}} = 5\text{V}$, $A_{\text{V}} = 1$, $R_{\text{L}} = 1\text{k}$		85		ns
ΔG	Differential Gain (NTSC)	$A_{\text{V}} = 2$, $R_{\text{L}} = 150$		0.01		%
$\Delta\theta$	Differential Phase (NTSC)	$A_{\text{V}} = 2$, $R_{\text{L}} = 150$		0.01		Deg

ELECTRICAL CHARACTERISTICS The ● denotes specifications which apply over the $0^{\circ}\text{C} < T_A < 70^{\circ}\text{C}$ temperature range. $V_S = \pm 5\text{V}$, $V_{\text{SHDN}} = \text{open}$; $V_{\text{CM}} = 0\text{V}$, $V_{\text{OUT}} = 0\text{V}$ unless otherwise noted.

SYMBOL	PARAMETER	CONDITIONS	MIN	TYP	MAX	UNITS
V_{OS}	Input Offset Voltage	$V_{\text{CM}} = V^+$	●	200	800	μV
		$V_{\text{CM}} = V^-$	●	200	800	μV
$V_{\text{OS TC}}$	Input Offset Voltage Drift (Note 8)	$V_{\text{CM}} = V^+$	●	1.5	5	$\mu\text{V}/^{\circ}\text{C}$
		$V_{\text{CM}} = V^-$	●	1.5	5	$\mu\text{V}/^{\circ}\text{C}$
ΔV_{OS}	Input Offset Voltage Shift	$V_{\text{CM}} = V^-$ to V^+	●	100	800	μV
I_{B}	Input Bias Current	$V_{\text{CM}} = V^+ - 0.1\text{V}$	●	1	6	μA
		$V_{\text{CM}} = V^- + 0.2\text{V}$	●	-15	-6	μA
ΔI_{B}	Input Bias Current Shift	$V_{\text{CM}} = V^- + 0.2\text{V}$ to $V^+ - 0.1\text{V}$	●	7	21	μA
I_{OS}	Input Offset Current	$V_{\text{CM}} = V^+ - 0.1\text{V}$	●	0.03	0.9	μA
		$V_{\text{CM}} = V^- + 0.2\text{V}$	●	0.04	1.9	μA
ΔI_{OS}	Input Offset Current Shift	$V_{\text{CM}} = V^- + 0.2\text{V}$ to $V^+ - 0.1\text{V}$	●	0.07	2.8	μA
A_{VOL}	Large Signal Voltage Gain	$V_{\text{O}} = -4\text{V}$ to 4V , $R_{\text{L}} = 1\text{k}\Omega$	●	100	250	V/mV
		$V_{\text{O}} = -2.5\text{V}$ to 2.5V , $R_{\text{L}} = 100\Omega$	●	10	25	V/mV
CMRR	Common Mode Rejection Ratio	$V_{\text{CM}} = V^-$ to V^+	●	81	100	dB
	Input Common Mode Range		●	V^-	V^+	V
PSRR	Power Supply Rejection Ratio	$V^+ = 2.5\text{V}$ to 10V , $V_{\text{CM}} = 0\text{V}$	●	89	105	dB
V_{OL}	Output Voltage Swing LOW (Note 7)	No Load	●	10	100	mV
		$I_{\text{SINK}} = 5\text{mA}$	●	45	160	mV
		$I_{\text{SINK}} = 25\text{mA}$	●	200	550	mV
V_{OH}	Output Voltage Swing HIGH (Note 7)	No Load	●	40	120	mV
		$I_{\text{SOURCE}} = 5\text{mA}$	●	110	240	mV
		$I_{\text{SOURCE}} = 25\text{mA}$	●	320	750	mV
I_{SC}	Short-Circuit Current		●	± 35	± 75	mA
I_{S}	Supply Current		●	14	20	mA
	Disable Supply Current	$V_{\text{SHDN}} = 0\text{V}$	●	0.4	1.4	mA
GBW	Gain Bandwidth Product	Frequency = 2MHz	●	150	300	MHz
SR	Slew Rate	$A_{\text{V}} = -1$, $R_{\text{L}} = 1\text{k}$, $V_{\text{O}} = \pm 4\text{V}$, Measure at $V_{\text{O}} = \pm 2\text{V}$	●	60	120	$\text{V}/\mu\text{s}$

ELECTRICAL CHARACTERISTICS The ● denotes the specifications which apply over the $-40^{\circ}\text{C} < T_A < 85^{\circ}\text{C}$ temperature range. $V_S = \pm 5\text{V}$, $V_{\text{SHDN}} = \text{open}$; $V_{\text{CM}} = 0\text{V}$, $V_{\text{OUT}} = 0\text{V}$ unless otherwise noted. (Note 5)

SYMBOL	PARAMETER	CONDITIONS	MIN	TYP	MAX	UNITS
V_{OS}	Input Offset Voltage	$V_{\text{CM}} = V^+$	●	200	900	μV
		$V_{\text{CM}} = V^-$	●	200	900	μV
$V_{\text{OS TC}}$	Input Offset Voltage Drift (Note 8)	$V_{\text{CM}} = V^+$	●	1.5	5	$\mu\text{V}/^{\circ}\text{C}$
		$V_{\text{CM}} = V^-$	●	1.5	5	$\mu\text{V}/^{\circ}\text{C}$
ΔV_{OS}	Input Offset Voltage Shift	$V_{\text{CM}} = V^-$ to V^+	●	100	900	μV
I_{B}	Input Bias Current	$V_{\text{CM}} = V^+ - 0.1\text{V}$	●	1.2	7	μA
		$V_{\text{CM}} = V^- + 0.2\text{V}$	●	-16	-5	μA
ΔI_{B}	Input Bias Current Shift	$V_{\text{CM}} = V^- + 0.2\text{V}$ to $V^+ - 0.1\text{V}$	●	6.2	23	μA
I_{OS}	Input Offset Current	$V_{\text{CM}} = V^+ - 0.1\text{V}$	●	0.03	1	μA
		$V_{\text{CM}} = V^- + 0.2\text{V}$	●	0.04	2.2	μA
ΔI_{OS}	Input Offset Current Shift	$V_{\text{CM}} = V^- + 0.2\text{V}$ to $V^+ - 0.1\text{V}$	●	0.07	3.2	μA
A_{VOL}	Large Signal Voltage Gain	$V_{\text{O}} = -4\text{V}$ to 4V , $R_{\text{L}} = 1\text{k}\Omega$	●	80	175	V/mV
		$V_{\text{O}} = -2\text{V}$ to 2V , $R_{\text{L}} = 100\Omega$	●	8	17	V/mV
CMRR	Common Mode Rejection Ratio	$V_{\text{CM}} = V^-$ to V^+	●	80	100	dB
		Input Common Mode Range	●	V^-	V^+	V
PSRR	Power Supply Rejection Ratio	$V^+ = 2.5\text{V}$ to 10V , $V_{\text{CM}} = 0\text{V}$	●	87	105	dB
V_{OL}	Output Voltage Swing LOW (Note 7)	No Load	●	20	120	mV
		$I_{\text{SINK}} = 5\text{mA}$	●	60	170	mV
		$I_{\text{SINK}} = 20\text{mA}$	●	200	500	mV
V_{OH}	Output Voltage Swing HIGH (Note 7)	No Load	●	50	140	mV
		$I_{\text{SOURCE}} = 5\text{mA}$	●	115	260	mV
		$I_{\text{SOURCE}} = 20\text{mA}$	●	360	700	mV
I_{SC}	Short-Circuit Current		●	± 25	± 55	mA
I_{S}	Supply Current		●	15	22	mA
		Disable Supply Current	●	$V_{\text{SHDN}} = 0\text{V}$	0.45	1.5
GBW	Gain Bandwidth Product	Frequency = 2MHz	●	125	250	MHz
SR	Slew Rate	$A_{\text{V}} = -1$, $R_{\text{L}} = 1\text{k}$, $V_{\text{O}} = \pm 4\text{V}$, Measure at $V_{\text{O}} = \pm 2\text{V}$	●	50	100	$\text{V}/\mu\text{s}$

Note 1: Absolute maximum ratings are those values beyond which the life of the device may be impaired.

Note 2: The inputs are protected by back-to-back diodes. If the differential input voltage exceeds 1.4V, the input current should be limited to less than 10mA.

Note 3: A heat sink may be required to keep the junction temperature below the absolute maximum rating when the output is shorted indefinitely.

Note 4: The LT1806C/LT1806I are guaranteed functional over the temperature range of -40°C and 85°C .

Note 5: The LT1806C is guaranteed to meet specified performance from 0°C to 70°C . The LT1806C is designed, characterized and expected to

meet specified performance from -40°C to 85°C but is not tested or QA sampled at these temperatures. The LT1806I is guaranteed to meet specified performance from -40°C to 85°C .

Note 6: Minimum supply voltage is guaranteed by power supply rejection ratio test.

Note 7: Output Voltage swings are measured between the output and power supply rails.

Note 8: This parameter is not 100% tested.

Note 9: Thermal resistance varies depending upon the amount of PC board metal attached to Pin 4 of the device. θ_{JA} is specified for a 2500mm² test board covered with 2 oz copper on both sides.

APPLICATIONS INFORMATION

Single Supply Video Line Driver

The LT1806 is a wideband rail-to-rail op amp with high output current that allows it to drive video signals in low supply applications. The figure on the front page depicts a single supply video line driver with AC coupling to minimize the quiescent power dissipation. Resistors R1 and R2 are used to level-shift the input and output to provide the largest signal swing. The gain of two is set up with R3 and R4 to restore the signal at V_{OUT} which is

attenuated by 6dB due to the matching of the 75Ω line with the back-terminated resistor, R5. The back termination will eliminate any reflection of the signal that comes from the load. The input termination resistor, R_T , is optional—it is used only if matching of the incoming line is necessary. The values of C1, C2 and C3 are selected to minimize the droop of the luminance signal. In some less stringent requirements, the value of capacitors could be reduced.

PACKAGE DESCRIPTION

Dimensions in inches (millimeters) unless otherwise noted.

S8 Package 8-Lead Plastic Small Outline (Narrow 0.150) (LTC DWG # 05-08-1610)

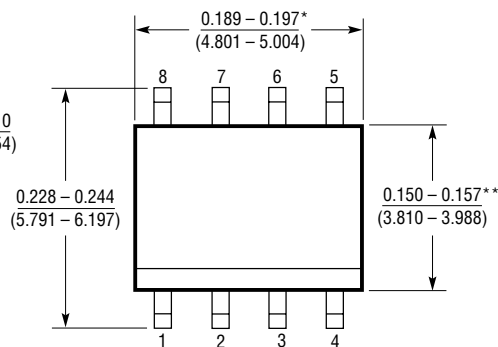
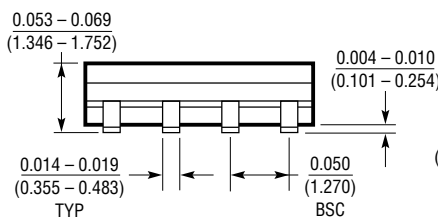
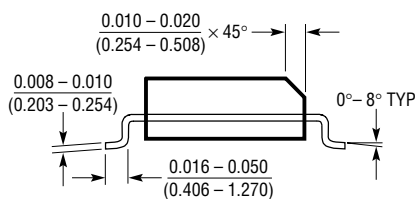

S08 1298

*DIMENSION DOES NOT INCLUDE MOLD FLASH. MOLD FLASH SHALL NOT EXCEED 0.006" (0.152mm) PER SIDE
**DIMENSION DOES NOT INCLUDE INTERLEAD FLASH. INTERLEAD FLASH SHALL NOT EXCEED 0.010" (0.254mm) PER SIDE

RELATED PARTS

PART NUMBER	DESCRIPTION	COMMENTS
LT1395	400MHz Current Feedback Amplifier	800V/ μ s Slew Rate, Shutdown
LT1399	Triple 300MHz Current Feedback Amplifier	0.1dB Gain Flatness to 150MHz, Shutdown
LT1809	180MHz Rail-to-Rail Amplifier	350V/ μ s Slew Rate, Shutdown