

Line Driver / Receiver

Description

The SL75232N, SL75232D are monolithic device containing 3 independent drives and 5 receivers. These are designed to interface between data terminal equipment and data communication equipment as designed by EIA-232-D.

Features

- Meets standard EIA-232-D (Revision of RS-232-C)
- Drivers
 - Current Limited Output 10 mA Typical
 - Power-off Output Impedance 300 Ω Min
 - Slew Rate Control by Load Capacitor
 - Flexible Supply Voltage Range
 - Input Compatible with Most TTL and DTL Circuits
- Receivers
 - Input Resistance 3 kΩ to 7 kΩ
 - Input Signal Range ± 30 V
 - Built-in Input Hysteresis (Double Threshold)
- 20 DIP/SO20: Ì S-001AD (SL75232N) / Ì S-013AÑ (SL75232D)

Block Diagram

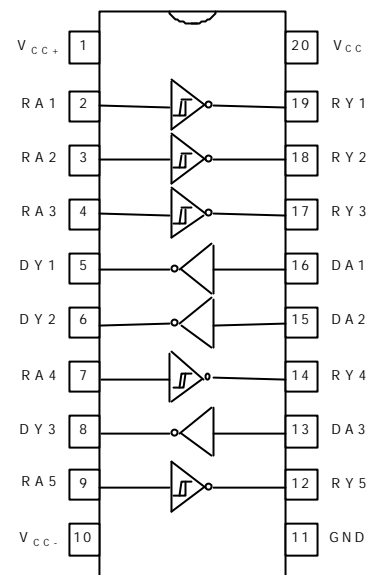

IL75232N, IL75232D

Pin Description

Name	Pin No	Function	Name	Pin No	Function
V _{CC+}	1	Driver Section Supply +	V _{CC-}	10	Driver Section Supply -
DA1	16	Driver Input	DY1	5	Driver Output
DA2	15		DY2	6	
DA3	13		DY3	8	
V _{CC}	20	Receiver Section Supply	GND	11	Ground
RA1	2	Receiver Input	RY1	19	Receiver Output
RA2	3		RY2	18	
RA3	4		RY3	17	
RA4	7		RY4	14	
RA5	9		RY5	12	

Absolute Maximum Ratings

Symbol	Parameter	Rating	Unit
V _{CC+}	Supply Voltage	15	V
V _{CC-}	Supply Voltage	-15	V
V _{CC}	Supply Voltage	10	V
VI (Driver)	Input Voltage	-15 ÷ +7	V
VI (Reciver)	Input Voltage	± 30	V
VO (Driver)	Output Voltage	-15 ÷ +15	V
PT	Continuous Power Dissipation (Below 25 °C)	1.0	W
T _{STG}	Storage Temperature	-65 ÷ +175	°C
Top	Operating Temperature	0 ÷ +75	°C

Schematic

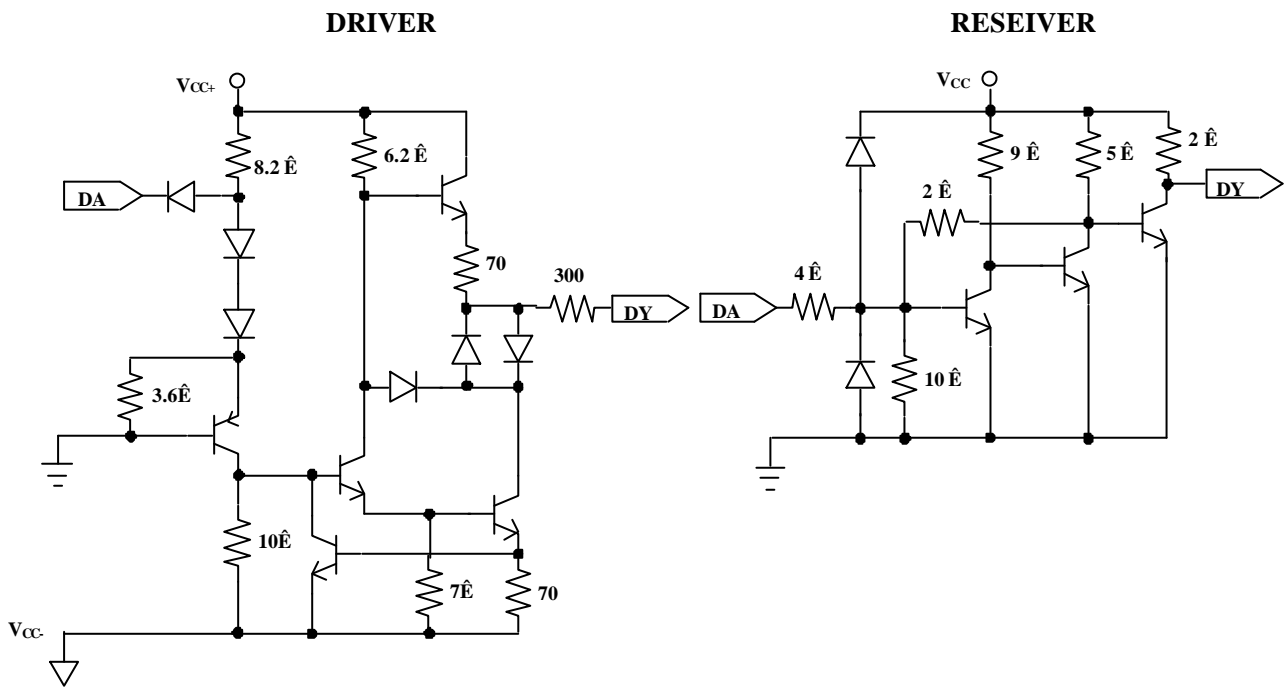

Electrical Characteristics

Supply Current

 $V_{CC} = 5V, T_A = 25^\circ C$

Symbol	Parameter	Test Conditions		Min	Max	Unit
I_{CC+}	Supply Current from V_{CC+}	$V_{CC+} = 9V$	$V_{IN} = 1.9V$		15	mA
		No Load	$V_{IN} = 0.8V$		4.5	
		$V_{CC+} = 12V$	$V_{IN} = 1.9V$		19	
I_{CC-}	Supply Current from V_{CC-}	No Load	$V_{IN} = 0.8V$		5.5	mA
		$V_{CC+} = 15V$	$V_{IN} = 1.9V$		25	
		No Load	$V_{IN} = 0.8V$		9	
I_{CC-}	Supply Current from V_{CC-}	$V_{CC-} = -9V$	$V_{IN} = 1.9V$		-15	mA
		No Load	$V_{IN} = 0.8V$		-3.2	
		$V_{CC-} = -12V$	$V_{IN} = 1.9V$		-19	
I_{CC}	Supply Current from V_{CC}	No Load	$V_{IN} = 0.8V$		-3.2	mA
		$V_{CC-} = -15V$	$V_{IN} = 1.9V$		-25	
		No Load	$V_{IN} = 0.8V$		-3.2	
I_{CC}	Supply Current from V_{CC}	$V_{CC} = 5V$	$V_{IN} = 5.0V$		30	mA

Driver Section

Symbol	Parameter	Test Conditions		Min	Max	Unit
V_{IH}	High Level Input Voltage	$V_{CC+} = 9V$		1.9		V
V_{IL}	Low Level Input Voltage	$V_{CC-} = -9V$			0.8	V
V_{OH}	High Level Output Voltage	$V_{IL} = 0.8V$ $R_L = 3k\Omega$	$V_{CC+} = 9V$ $V_{CC-} = -9V$	6		V
			$V_{CC+} = 13.2V$ $V_{CC-} = -13.2V$	9		
V_{OL}	Low Level Output Voltage	$V_{IH} = 1.9V$ $R_L = 3k\Omega$	$V_{CC+} = 9V$ $V_{CC-} = -9V$		-6	V
			$V_{CC+} = 13.2V$ $V_{CC-} = -13.2V$		-9	
I_{IH}	High Level Input Current	$V_I = 5V$			10	μA
I_{IL}	Low Level Input Current	$V_I = 0$			-1.6	mA
$I_{OS(H)}$	Short Circuit Output Current at High Level	$V_I = 0.8V$ $V_O = 0$		-6	-12	mA
$I_{OS(L)}$	Short Circuit Output Current at Low Level	$V_I = 1.9V$ $V_O = 0$		6	12	mA
R_O	Output Resistance,	$V_{CC+} = 0, V_{CC-} = 0$		300		Ω

Power Off	$V_O = -2V$ to $2V$			
-----------	---------------------	--	--	--

Driver Switching Characteristic

$V_{CC+} = 9V, V_{CC-} = -9V, T_A = 25^\circ C$

Symbol	Parameter	Test Conditions	Min	Max	Unit
t_{PLH}	Propagation Delay Time, Low-To-High-Level Output	$R_L = 3\text{ k}\Omega$ $C_L = 15\text{ }\mu\text{F}$		500	ns
t_{PHL}	Propagation Delay Time, High -To- Low -Level Output	See Figure 1		175	ns
t_{TLH}	Transition Time, Low-To-High-Level Output *			100	ns
t_{THL}	Transition Time, High -To- Low -Level Output*			75	ns
t_{TLH}	Transition Time, Low-To-High-Level Output**		$R_L = 3\text{ k}\Omega$ to $7\text{ k}\Omega$ $C_L = 2500\text{ }\rho\text{F}$	2.5 (tip)	
t_{THL}	Transition Time, High-To-Low -Level Output**	See Figure 1	3.0 (tip)		μs

*- Measured between 10 % and 90 % Points of Output Waveform

** - Measured between +3V and -3V Points on the Output Waveform (EIA-232-D Condition)

Receiver Section

Symbol	Parameter	Test Conditions	Min	Max	Unit
V_{T+}	Positive-Going Threshold Voltage		1.75	2.25	V
V_{T-}	Negative-Going Threshold Voltage		0.75	1.25	V
V_{OH}	High Level Output Voltage	$V_I = 0.75V, I_{OL} = -0.5mA$	2.6	5	V
		Input Open, $I_{OL} = -0.5\text{ mA}$	2.6	5	
V_{OL}	Low Level Output Voltage	$V_I = 3V, I_{OL} = 10\text{ mA}$		0.45	V
I_{IH}	High-Level Input Current	$V_I = 25V$	3.6	8.3	mA
		$V_I = 3V$	0.43		
I_{IL}	Low-Level Input Current	$V_I = -25V$	-3.6	-8.3	mA
		$V_I = -3V$	-0.43		
I_{OS}	Short-Circuit Output Current		-3 (tip)		mA

Receiver Switching Characteristic

$V_{CC} = 5V$

Symbol	Parameter	Test Conditions	Min	Max	Unit
t_{PLH}	Propagation Delay Time, Low-To-High-Level Output	$C_L = 15\text{ }\rho\text{F}$ $R_L = 3.9\text{ k}\Omega$		190	ns
t_{PHL}	Propagation Delay Time, High -To- Low -Level Output	$C_L = 15\text{ }\rho\text{F}$ $R_L = 390\text{ k}\Omega$		60	ns
t_{TLH}	Transition Time, Low-To-High-Level Output	$C_L = 15\text{ }\rho\text{F}$ $R_L = 3.9\text{ k}\Omega$		175	ns

t_{THL}	Transition Time, High -To- Low -Level Output	$C_L = 15 \text{ pF}$ $R_L = 390 \text{ k}\Omega$		20	ns
-----------	---	--	--	----	----

Parameter Measurement Information

DRIVER

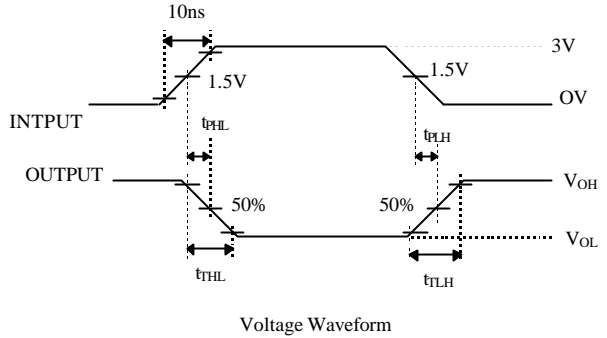
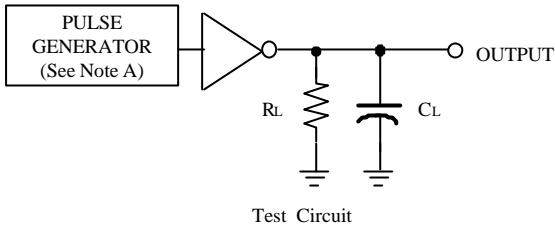

RESEIVER

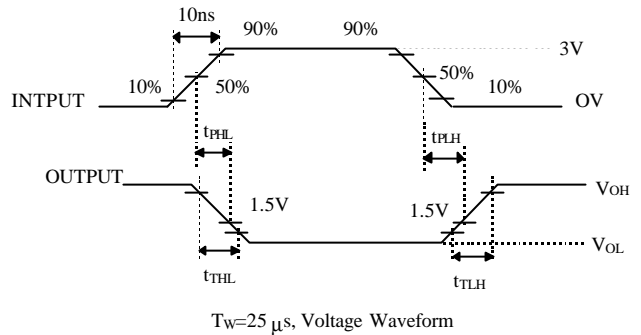
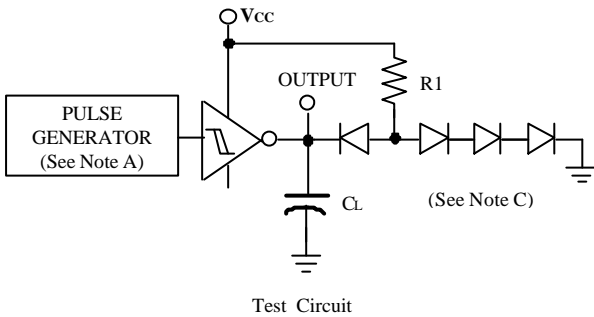

- Note
- A. The pulse generator has the following characteristics. $f = 200 \text{ KHz}$, $Z_O = 50 \Omega$
 - B. C included probe and jig capacitance.
 - C. All diodes are 1N3064 or equivalent.

Fig1. Propagation and Transition Times

Typical Application

