

## FEATURES

- Translates positive ECL to TTL (PECL-to-TTL)
- 300ps pin-to-pin skew
- 500ps part-to-part skew
- Differential internal design for increased noise immunity and stable threshold inputs
- V<sub>BB</sub> reference output
- Single supply
- Enable input
- Latch enable input
- Extra TTL and ECL power/ground pins to reduce cross-talk/noise
- High drive capability: 24mA each output
- Fully compatible with industry standard 10K, 100K I/O levels
- Available in 16-pin SOIC package

## DESCRIPTION

The SY10/100H841 are single supply, low skew translating 1:4 clock drivers.

The devices feature a 24mA TTL output stage, with AC performance specified into a 50pF load capacitance.

A latch is provided on-chip. When LEN is LOW (or left open, in which case it is pulled low by the internal pull-downs) the latch is transparent. A HIGH on the enable pin ( $\overline{EN}$ ) forces all outputs LOW.

As frequencies increase to 40MHz and above, precise timing and shaping of clock signals becomes extremely important. The H841 solves several clock distribution problems such as minimizing skew (300ps), maximizing clock fanout (24mA drive), and precise duty cycle control through a proprietary differential internal design.

The 10K version is compatible with 10KH ECL logic levels. The 100K version is compatible with 100K levels.

## BLOCK DIAGRAM

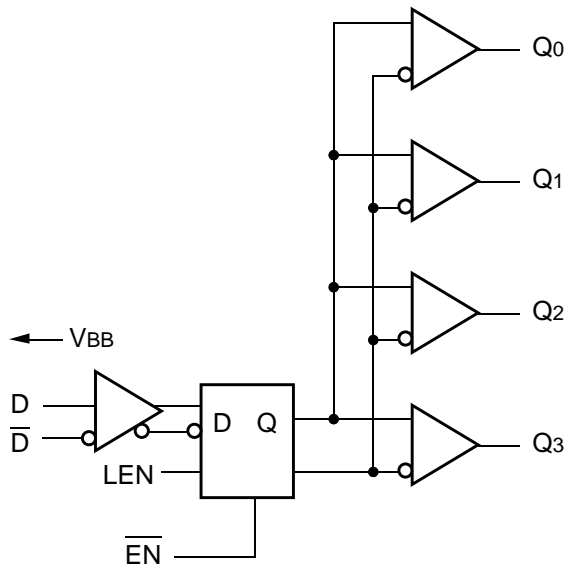

## PIN CONFIGURATION

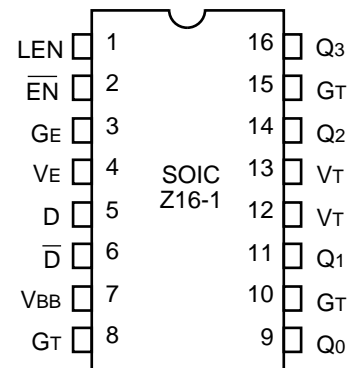

## PIN NAMES

Pin	Function
GT	TTL Ground (0V)
VT	TTL Vcc (+5.0V)
VE	ECL Vcc (+5.0V)
GE	ECL Ground (0V)
D, $\overline{D}$	Signal Input (PECL)
V <sub>BB</sub>	V <sub>BB</sub> Reference Output (PECL)
Q <sub>0</sub> - Q <sub>3</sub>	Signal Outputs (TTL)
$\overline{EN}$	Enable Input (PECL)
LEN	Latch Enable Input

**TRUTH TABLE**

D	LEN	EN	Q
L	L	L	L
H	L	L	H
X	X	H	L
X	H	L	Latch

**ABSOLUTE MAXIMUM RATINGS<sup>(1)</sup>**

Symbol	Rating	Value	Unit
VE (ECL) VT (TTL)	Power Supply Voltage	-0.5 to +7.0 -0.5 to +7.0	V
VI (ECL) VOUT (TTL)	Input Voltage	0.0 to VEE 0.0 to VT	V
T <sub>store</sub>	Storage Temperature	-65 to +150	°C
TA	Operating Temperature	0 to +85	°C

**NOTE:**

1. Permanent device damage may occur if ABSOLUTE MAXIMUM RATINGS are exceeded. This is a stress rating only and functional operation is not implied at conditions other than those detailed in the operational sections of this data sheet. Exposure to ABSOLUTE MAXIMUM RATING conditions for extended periods may affect device reliability.

**PIN DESCRIPTION**

Pin	Symbol	Description
1	LEN	Latch Enable Input
2	EN	Enable Input (PECL)
3	GE	ECL Ground (0V)
4	VE	ECL Vcc (+5.0V)
5	D	ECL Signal Input (Non-inverting)
6	D̄	ECL Signal Input (Inverting)
7	VBB	VBB Reference Output (PECL)
8	GT	TTL Ground (0V)
9	Q0	Signal Output (TTL)
10	GT	TTL Ground (0V)
11	Q1	Signal Output (TTL)
12	VT	TTL Vcc (+5.0V)
13	VT	TTL Vcc (+5.0V)
14	Q2	Signal Output (TTL)
15	GT	TTL Ground (0V)
16	Q3	Signal Output (TTL)

**VCC AND CLOAD**

Ranges to meet duty cycle requirement: 0°C ≤ TA ≤ 85°C. Output duty cycle measured relative to 1.5V.

Symbol	Parameter		Min.	Typ.	Max.	Unit	Condition
PW	Ranges of Vcc and CL to meet min. pulse width (HIGH or LOW) at f <sub>OUT</sub> ≤ 40MHz	Vcc	4.75	5.0	5.25	V	All Outputs
		CL	10	—	50	pF	
		PW	11	—	—	ns	
PW	Ranges of Vcc and CL to meet min. pulse width (HIGH or LOW) at f <sub>OUT</sub> ≤ 50MHz	Vcc	4.875	5.0	5.125	V	All Outputs
		CL	15	—	27	pF	
		PW	9.0	—	—	ns	

**DC CHARACTERISTICS**

VT = VE = 5.0V ± 5%

Symbol	Parameter		TA = 0°C		TA = +25°C		TA = +85°C		Unit	Condition
			Min.	Max.	Min.	Max.	Min.	Max.		
IEE	Power Supply Current	ECL	—	40	—	40	—	40	mA	VE Pin
ICCH	Power Supply Current	TTL	—	20	—	20	—	20	mA	Total all VT pins
ICCL			—	25	—	25	—	25		

**TTL DC ELECTRICAL CHARACTERISTICS**

$V_T = V_E = +5.0V \pm 5\%$

Symbol	Parameter	TA = 0°C		TA = +25°C		TA = +85°C		Unit	Condition
		Min.	Max.	Min.	Max.	Min.	Max.		
V <sub>OH</sub>	Output HIGH Voltage	2.5 2.0	— —	2.5 2.0	— —	2.5 2.0	— —	V	I <sub>OH</sub> = -3.0mA I <sub>OH</sub> = -15mA
V <sub>OL</sub>	Output LOW Voltage	—	0.5	—	0.5	—	0.5	V	I <sub>OL</sub> = 24mA
I <sub>OS</sub>	Output Short Circuit Current	-80	-200	-80	-200	-80	-200	mA	V <sub>OUT</sub> = 0V

**10H ECL DC ELECTRICAL CHARACTERISTICS<sup>(1)</sup>**

$V_T = V_E = +5.0V \pm 5\%$

Symbol	Parameter	TA = 0°C		TA = +25°C		TA = +85°C		Unit	Condition
		Min.	Max.	Min.	Max.	Min.	Max.		
I <sub>IH</sub>	Input HIGH Current	—	225	—	175	—	175	μA	—
I <sub>IL</sub>	Input LOW Current	0.5	—	0.5	—	0.5	—	μA	—
V <sub>IH</sub>	Input HIGH Voltage	3.830	4.160	3.870	4.190	3.940	4.280	V	V <sub>E</sub> = 5.0V
V <sub>IL</sub>	Input LOW Voltage	3.050	3.520	3.050	3.520	3.050	3.555	V	V <sub>E</sub> = 5.0V
V <sub>BB</sub>	Output Reference Voltage	3.620	3.730	3.650	3.750	3.690	3.810	V	V <sub>E</sub> = 5.0V

**NOTE:**

1. ECL V<sub>IH</sub>, V<sub>IL</sub> and V<sub>BB</sub> are referenced to V<sub>CC</sub>E and will vary 1:1 with the power supply. The levels shown are for I<sub>VT</sub> = I<sub>VO</sub> = V<sub>CC</sub>E = +5.0V.

**100H ECL DC ELECTRICAL CHARACTERISTICS<sup>(1)</sup>**

$V_T = V_E = +5.0V \pm 5\%$

Symbol	Parameter	TA = 0°C		TA = +25°C		TA = +85°C		Unit	Condition
		Min.	Max.	Min.	Max.	Min.	Max.		
I <sub>IH</sub>	Input HIGH Current	—	225	—	175	—	175	μA	—
I <sub>IL</sub>	Input LOW Current	0.5	—	0.5	—	0.5	—	μA	—
V <sub>IH</sub>	Input HIGH Voltage	3.835	4.120	3.835	4.120	3.835	4.120	V	V <sub>E</sub> = 5.0V
V <sub>IL</sub>	Input LOW Voltage	3.190	3.525	3.190	3.525	3.190	3.525	V	V <sub>E</sub> = 5.0V
V <sub>BB</sub>	Output Reference Voltage	3.620	3.740	3.620	3.740	3.620	3.740	V	V <sub>E</sub> = 5.0V

**NOTE:**

1. ECL V<sub>IH</sub>, V<sub>IL</sub> and V<sub>BB</sub> are referenced to V<sub>CC</sub>E and will vary 1:1 with the power supply. The levels shown are for I<sub>VT</sub> = I<sub>VO</sub> = V<sub>CC</sub>E = +5.0V.

**AC CHARACTERISTICS**V<sub>T</sub> = V<sub>E</sub> = 5.0V ± 5%

Symbol	Parameter		T <sub>A</sub> = 0°C		T <sub>A</sub> = +25°C		T <sub>A</sub> = +85°C		Unit	Condition
			Min.	Max.	Min.	Max.	Min.	Max.		
t <sub>PLH</sub> t <sub>PHL</sub>	Propagation Delay D to Output	Q <sub>0</sub> –Q <sub>3</sub>	2.7	3.7	2.7	3.7	2.7	3.7	ns	CL = 50pF
t <sub>skpp</sub>	Part-to-Part Skew <sup>(1,4)</sup>	Q <sub>0</sub> –Q <sub>3</sub>	—	0.5	—	0.5	—	0.5	ns	CL = 50pF
t <sub>skew++</sub>	Within-Device Skew <sup>(2,4)</sup>	Q <sub>0</sub> –Q <sub>3</sub>	—	0.3	—	0.3	—	0.3	ns	CL = 50pF
t <sub>skew--</sub>	Within-Device Skew <sup>(3,4)</sup>	Q <sub>0</sub> –Q <sub>3</sub>	—	0.3	—	0.3	—	0.3	ns	CL = 50pF
t <sub>PLH</sub> t <sub>PHL</sub>	Propagation Delay LEN to Q	Q <sub>0</sub> –Q <sub>3</sub>	2.7	3.7	2.7	3.7	2.7	3.7	ns	CL = 50pF
t <sub>PLH</sub> t <sub>PHL</sub>	Propagation Delay EN to Output	Q <sub>0</sub> –Q <sub>3</sub>	2.7	3.7	2.7	3.7	2.7	3.7	ns	CL = 50pF
t <sub>r</sub> t <sub>f</sub>	Output Rise/Fall Time 1.0V to 2.0V	Q <sub>0</sub> –Q <sub>3</sub>	—	1.5	—	1.5	—	1.5	ns	CL = 50pF
f <sub>MAX</sub>	Max. Input Frequency <sup>(5,6)</sup>	Q <sub>0</sub> –Q <sub>3</sub>	160	—	160	—	160	—	MHz	CL = 50pF
—	Pulse Width	Q <sub>0</sub> –Q <sub>3</sub>	1.5	—	1.5	—	1.5	—	ns	—
—	Recovery Time EN	Q <sub>0</sub> –Q <sub>3</sub>	1.0	—	1.0	—	1.0	—	ns	—
t <sub>s</sub>	Set-up Time D, EN	Q <sub>0</sub> –Q <sub>3</sub>	0.75	—	0.75	—	0.75	—	ns	—
t <sub>h</sub>	Hold Time D, EN	Q <sub>0</sub> –Q <sub>3</sub>	0.75	—	0.75	—	0.75	—	ns	—

**NOTES:**

1. Device-to-Device Skew considering HIGH-to-HIGH transitions at common V<sub>CC</sub> level.
2. Within-Device Skew considering HIGH-to-HIGH transitions at common V<sub>CC</sub> level.
3. Within-Device Skew considering LOW-to-LOW transitions at common V<sub>CC</sub> level.
4. All skew parameters are guaranteed but not tested.
5. Frequency at which output levels will meet at 0.8V to 2.0V minimum swing.
6. The f<sub>MAX</sub> value is specified as the minimum guaranteed maximum frequency. Actual operational maximum frequency may be greater.

**PRODUCT ORDERING CODE**

Ordering Code	Package Type	Operating Range
SY10H841ZC	Z16-1	Commercial
SY10H841ZCTR	Z16-1	Commercial
SY100H841ZC	Z16-1	Commercial
SY100H841ZCTR	Z16-1	Commercial

**TTL SWITCHING CIRCUIT**

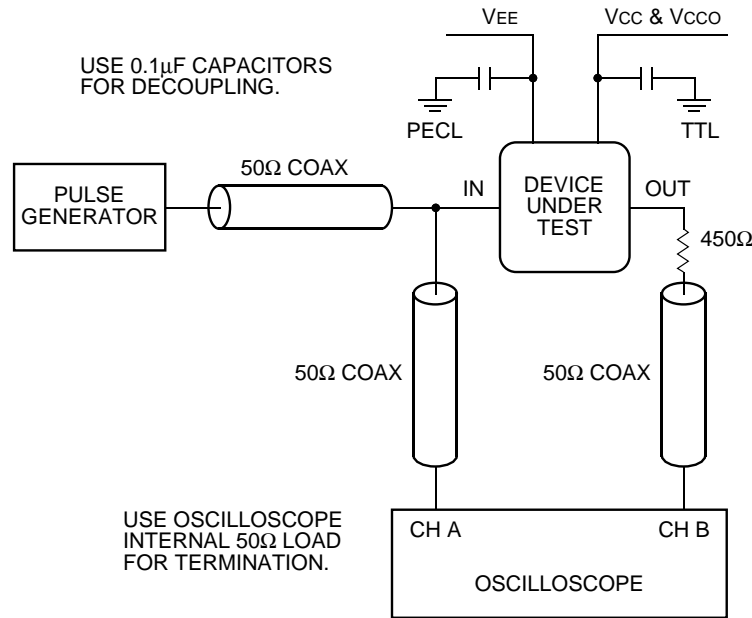

**ECL/TTL PROPAGATION DELAY — SINGLE ENDED**

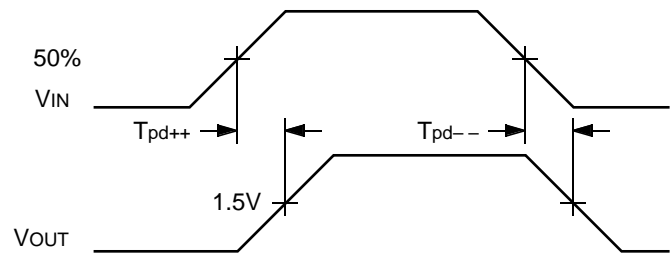

**ECL/TTL WAVEFORMS: RISE AND FALL TIMES**

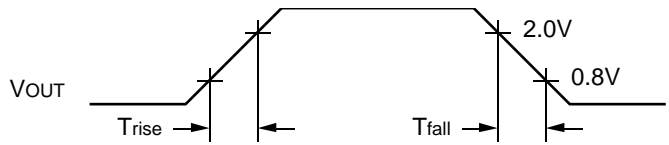

**16 LEAD SOIC .300" WIDE (Z16-1)**

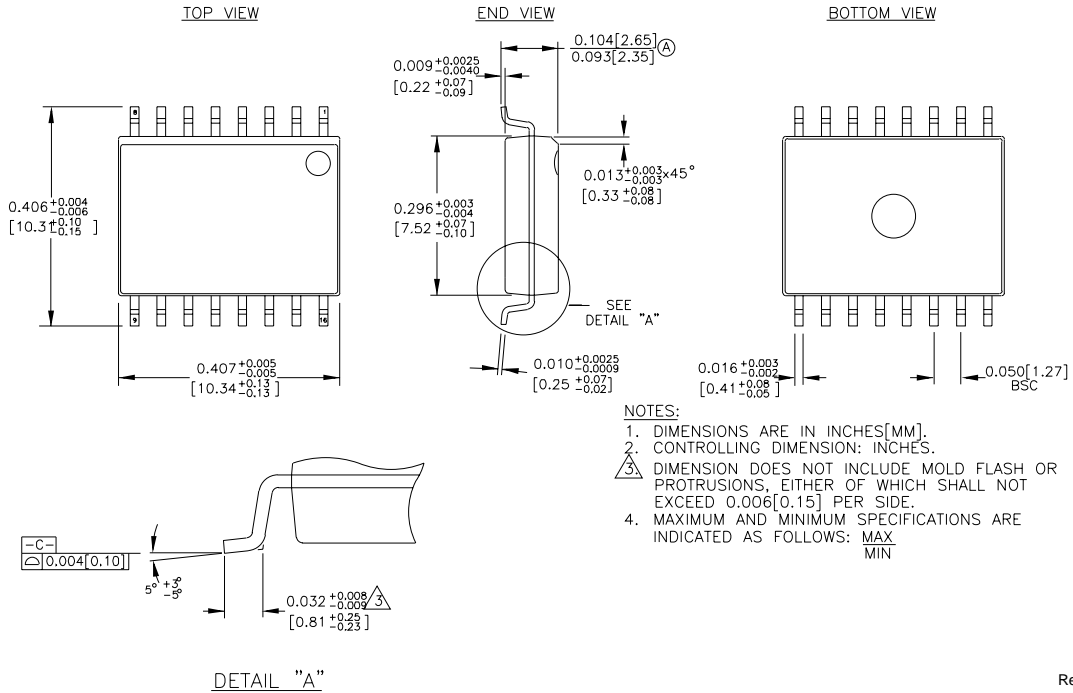

Rev. 03

**MICREL-SYNERGY 3250 SCOTT BOULEVARD SANTA CLARA CA 95054 USA**

TEL + 1 (408) 980-9191 FAX + 1 (408) 914-7878 WEB <http://www.micrel.com>

This information is believed to be accurate and reliable, however no responsibility is assumed by Micrel for its use nor for any infringement of patents or other rights of third parties resulting from its use. No license is granted by implication or otherwise under any patent or patent right of Micrel Inc.

© 2000 Micrel Incorporated