

Single-Chip Digital Signal Processor for Karaoke

Description

The CXD2720Q-2 is a digital signal processor LSI for Karaoke, suitable for use in LD/CD/CD-G/video CD and the like.

A large capacity DRAM and AD/DA converters are built in, and Karaoke functions such as key control and microphone echo are contained on a single chip.

Features

- 3-channel 1-bit AD converter and decimation filter
S/N ratio: 88 dB
THD + N: 0.016%
Filter pass band ripple: less than ± 0.008 dB
Filter stop band attenuation: less than -62 dB
(all characteristics are typical values)
- 2-channel 1-bit DA converter and oversampling filter
S/N ratio: 98dB
THD + N: 0.006%
Filter pass band ripple: less than ± 0.2 dB
Filter stop band attenuation: less than -41 dB
(all characteristics are typical values)
- In addition to analog input/output, 2-channel input/2-channel output of digital input/output are provided. The interface also supports a variety of formats.
- 128K-bit DRAM for key control and microphone echo processing

Functions

- Key controller pitch setting can be varied to a maximum of ± 1 octave with a precision of 14 bits
- Two key controllers are provided.
For their pitches, either of common or independent setting is possible
- Key controller can be used for voice
- Microphone echo delay time can be varied to a maximum of 185ms (when $f_s = 44.1$ kHz)
- Voice parametric equalizer
- Mixing function to support sound multiplexing software
- Digital de-emphasis function
- Soft mute function

Sony reserves the right to change products and specifications without prior notice. This information does not convey any license by any implication or otherwise under any patents or other right. Application circuits shown, if any, are typical examples illustrating the operation of the devices. Sony cannot assume responsibility for any problems arising out of the use of these circuits.

100 pin QFP (Plastic)

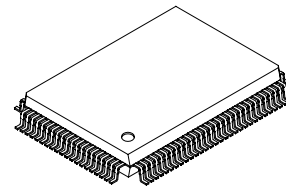
**Structure**

Silicon gate CMOS

Applications

Equipment having Karaoke function, such as LD/CD, compact music center, video games, etc.

Absolute Maximum Ratings

| | (Ta = 25°C, Vss = 0V) | | |
|-------------------------|-----------------------|--|----|
| • Supply voltage | V _{DD} | V _{SS} - 0.5 to +7.0 | V |
| • Input voltage | V _I | V _{SS} - 0.5 to V _{DD} + 0.5 | V |
| • Output voltage | V _O | V _{SS} - 0.5 to V _{DD} + 0.5 | V |
| • Operating temperature | T _{opr} | -20 to +75 | °C |
| • Storage temperature | T _{stg} | -55 to +150 | °C |

Recommended Operating Conditions

| | | | |
|-------------------------|-----------------|-----------------------|----|
| • Supply voltage | V _{DD} | 4.5 to 5.5 (5.0 typ.) | V |
| • Operating temperature | T _a | -20 to +75 | °C |

Input/Output Capacitance

| | | | |
|----------------------------|------------------|-----------|----|
| • Input capacitance | C _{IN} | 9 (max.) | pF |
| • Output capacitance | C _{OUT} | 11 (max.) | pF |
| • Input/output capacitance | C _{I/O} | 11 (max.) | pF |

* Measurement conditions: V_{DD} = V_I = 0V, F = 1MHz

Block Diagram

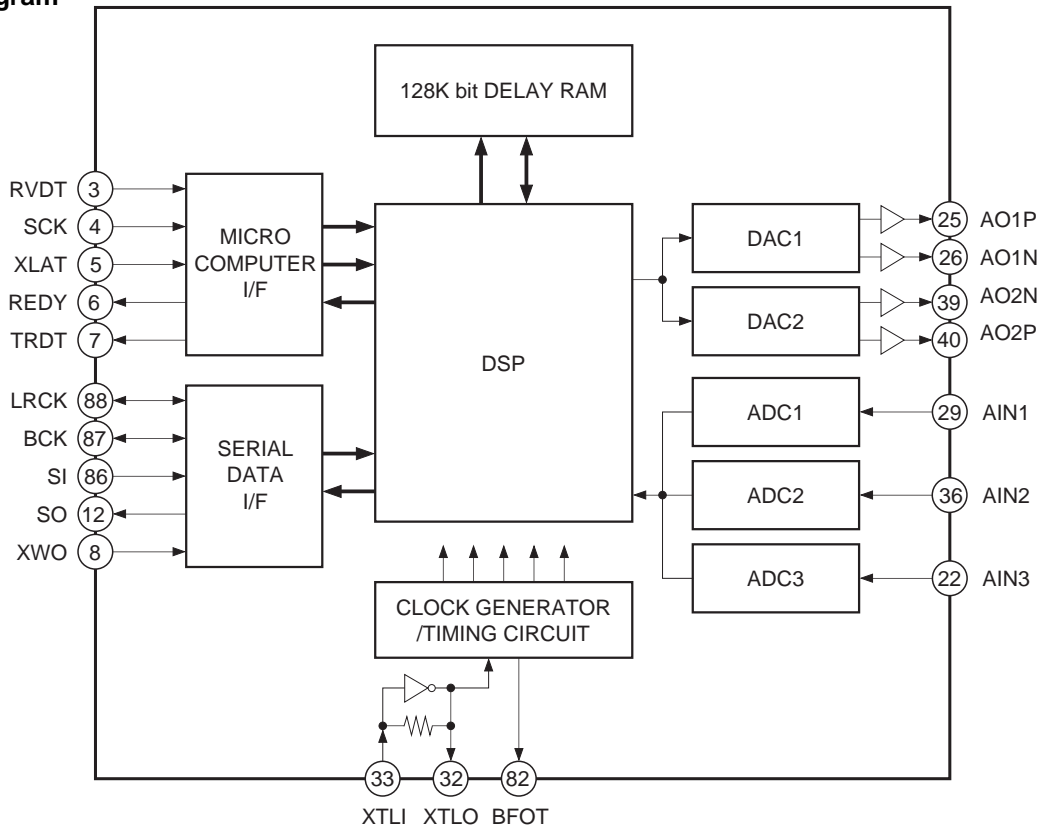

Pin Configuration



Pin Description

| Pin No. | Symbol | I/O | Description |
|---------|--------|-----|--|
| 1 | AVs0 | — | DRAM digital GND. |
| 2 | Vss0 | — | Digital GND. |
| 3 | RVDT | I | Data input for microcomputer interface. |
| 4 | SCK | I | Shift clock input for microcomputer interface. |
| 5 | XLAT | I | Latch input for microcomputer interface. |
| 6 | REDY | O | Transmission enabling signal output for microcomputer interface. Transmission prohibited when Low. |
| 7 | TRDT | O | Serial data output for microcomputer interface. |
| 8 | XWO | I | Window open input for synchronization. Normally High. |
| 9 | XRST | I | System reset input. Resets when Low. |
| 10 | Vss1 | — | Digital GND. |
| 11 | Vdd0 | — | Digital power supply. |
| 12 | SO | O | 1-sampling 2-channel serial data output. |
| 13 | XS24 | I | Serial data 24-/32-bit slot selection. 24-bit slot when Low. (valid for slave mode) |
| 14 | TST0 | I | Test pin. Normally set Low. |
| 15 | TST1 | I | Test pin. Normally set Low. |
| 16 | TST2 | I | Test pin. Normally set Low. |
| 17 | TST3 | I | Test pin. Normally set Low. |
| 18 | TST4 | I | Test pin. Normally set Low. |
| 19 | TST5 | I | Test pin. Normally set Low. |
| 20 | Vss2 | — | Digital GND. |
| 21 | AVs3 | — | CH3 AD converter GND. |
| 22 | AIN3 | I | CH3 AD converter analog input (for microphone input). |
| 23 | AVb3 | — | CH3 AD converter power supply. |
| 24 | AVb4 | — | CH1 DA converter power supply. |
| 25 | AO1P | O | CH1 DA converter analog positive phase output. |
| 26 | AO1N | O | CH1 DA converter analog reversed phase output. |
| 27 | AVs4 | — | CH1 DA converter GND. |
| 28 | AVs1 | — | CH1 AD converter GND. |
| 29 | AIN1 | I | CH1 AD converter analog input. |
| 30 | AVb1 | — | CH1 AD converter power supply. |
| 31 | XVDD | — | Digital power supply for master clock. |
| 32 | XTLO | O | Crystal oscillator circuit output. |
| 33 | XTLI | I | Crystal oscillator circuit input. |
| 34 | XVss | — | Digital GND for master clock. |
| 35 | AVs2 | — | CH2 AD converter GND. |

| Pin No. | Symbol | I/O | Description |
|----------|-------------------|-----|---|
| 36 | AIN2 | I | CH2 AD converter analog input. |
| 37 | AV _D 2 | — | CH2 AD converter power supply. |
| 38 | AV _D 5 | — | CH2 DA converter power supply. |
| 39 | AO2N | O | CH2 DA converter analog reversed phase output. |
| 40 | AO2P | O | CH2 DA converter analog positive phase output. |
| 41 | AV _S 5 | — | CH2 DA converter GND. |
| 42 | V _{SS} 3 | — | Digital GND. |
| 43 | V _{DD} 1 | — | Digital power supply. |
| 44 to 52 | NC | | Normally open. |
| 53 | V _{SS} 4 | — | Digital GND. |
| 54 to 68 | NC | | Normally open. |
| 69 | V _{SS} 5 | — | Digital GND. |
| 70 | V _{DD} 2 | — | Digital power supply. |
| 71 to 79 | NC | | Normally open. |
| 80 | V _{SS} 6 | — | Digital GND. |
| 81 | X768 | I | Test input pin. Normally set Low. |
| 82 | BFOT | O | Clock, frequency-divider output (384fs). |
| 83 | INVI | I | Test pin. Normally set Low. |
| 84 | NC | | Normally open. |
| 85 | NC | | Normally open. |
| 86 | SI | I | 1-sampling 2-channel serial data input. |
| 87 | BCK | I/O | Serial bit transmission clock for serial input/output data SI and SO. |
| 88 | LRCK | I/O | Sampling frequency clock for serial input/output data SI and SO. |
| 89 | XMST | I | BCK, LRCK master/slave mode switching input. Master mode when Low. |
| 90 | V _{SS} 7 | — | Digital GND. |
| 91 to 98 | NC | | Normally open. |
| 99 | V _{DD} 3 | — | Digital power supply. |
| 100 | AV _D 0 | — | Digital power supply for DRAM. |

DC Characteristics

(AV_{D0} to 5 = XV_{DD} = V_{DD0} to 3 = 5V ± 10%, AV_{S0} to 5 = XV_{SS} = V_{SS0} to 7 = 0V, Ta = -20 to +75°C)

| Item | Symbol | Conditions | Min. | Typ. | Max. | Unit | Applicable pins | |
|------------------------|-----------------|---|---------------------------|-----------------------|--------------------|-----------------|-----------------|--------------------------------|
| Input voltage (1) | High level | V _{IH} | | 0.7V _{DD} | | V | *1, *4, *5 | |
| | Low level | V _{IL} | | | 0.3V _{DD} | V | *1, *4, *5 | |
| Input voltage (2) | High level | V _{IH} | | 0.8V _{DD} | | V | *3 | |
| | Low level | V _{IL} | | | 0.2V _{DD} | V | *3 | |
| Input voltage (3) | | V _{IN} | Analog input | V _{SS} | | V _{DD} | V | *2 |
| Output voltage (1) | High level | V _{OH} | I _{OH} = -2.0mA | V _{DD} - 0.8 | | V | *6, *7, *8 | |
| | Low level | V _{OL} | I _{OL} = 4.0mA | | 0.4 | V | *6, *7, *8, *9 | |
| Output voltage (2) | High level | V _{OH} | I _{OH} = -6.0mA | V _{DD} - 0.8 | | V | *10 | |
| | Low level | V _{OL} | I _{OL} = 4.0mA | | 0.4 | V | *10 | |
| Output voltage (3) | High level | V _{OH} | I _{OH} = -12.0mA | V _{DD} /2 | | V | *11 | |
| | Low level | V _{OL} | I _{OL} = 12.0mA | | V _{DD} /2 | V | *11 | |
| Input leak current (1) | I _I | V _{IH} = V _{DD} , V _{SS} | | -10 | 10 | μA | *1, *3, *5 | |
| Input leak current (2) | I _I | V _{IH} = V _{DD} , V _{SS} | | -40 | 40 | μA | *4 | |
| Output leak current | I _{OZ} | V _{IH} = V _{DD} , V _{SS} | | -40 | 40 | μA | *8, *9 | |
| Feedback resistance | R _{Fb} | | | 250k | 1M | 2.5M | Ω | Resistance between *5 and *11. |
| Current consumption | I _{DD} | f _s = 44.1kHz | | | 79 | 90 | mA | |

*1 RVDT, SCK, XLAT, XWO, XRST, XS24, TST0 to TST5, X768, SI, XMST

*2 AIN1, AIN2, AIN3

*3 INVI

*4 During input to bidirectional pins BCK, LRCK

*5 XTLI

*6 During output from bidirectional pins BCK, LRCK

*7 SO, BFOT

*8 TRDT

*9 REDY

*10 AO1P, AO1N, AO2N, AO2P

*11 XTLO

AC Characteristics

(AV_{D0} to 5 = XV_{DD} = V_{DD0} to 3 = 5V±10%, AV_{s0} to 5 = XV_{SS} = V_{SS0} to 7 = 0V, Ta = -20 to +75°C)

Serial Audio Interface Timing

[Slave mode]

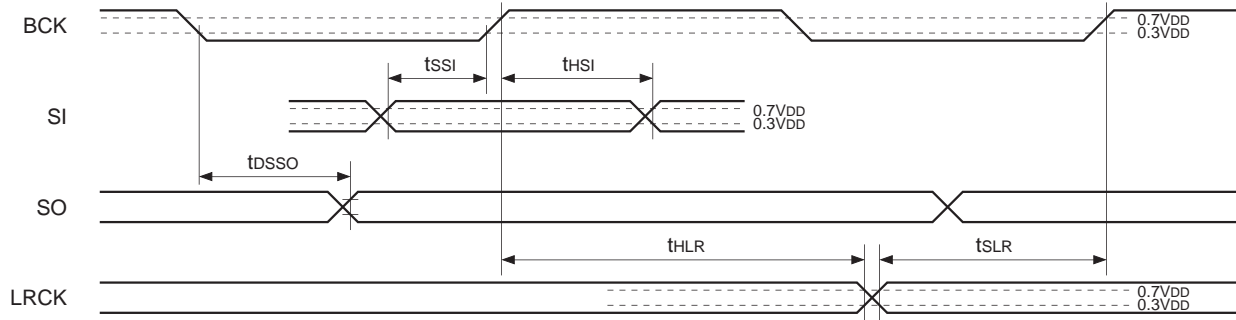

[Master mode]

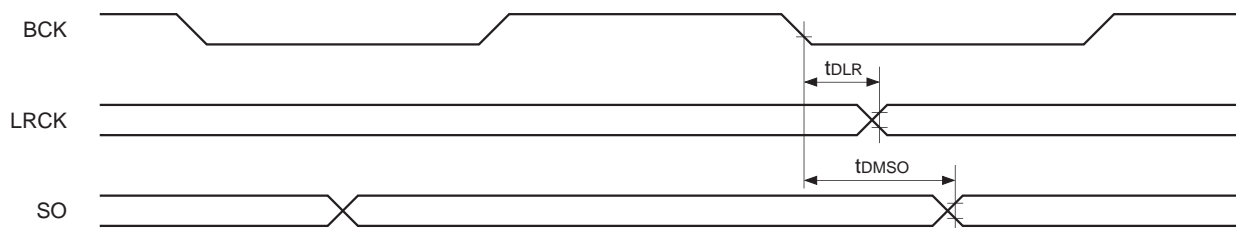

| Item | Symbol | Conditions | Min. | Max. | Unit |
|-----------------|-------------------|-------------------------|------|------|------|
| SI setup time | t _{SSI} | Slave mode | 20 | | ns |
| SI hold time | t _{HSI} | Slave mode | 40 | | ns |
| SO delay time | t _{DSSO} | Slave mode, CL = 60pF | | 50 | ns |
| LRCK setup time | t _{SLR} | Slave mode | 20 | | ns |
| LRCK hold time | t _{HLR} | Slave mode | 40 | | ns |
| LRCK delay time | t _{DLR} | Master mode, CL = 120pF | | 50 | ns |
| SO delay time | t _{DMSO} | Master mode, CL = 60pF | | 100 | ns |

Microcomputer Interface Timing

[Write]

- Transmission timing for address section, transmission mode section, data section LSB

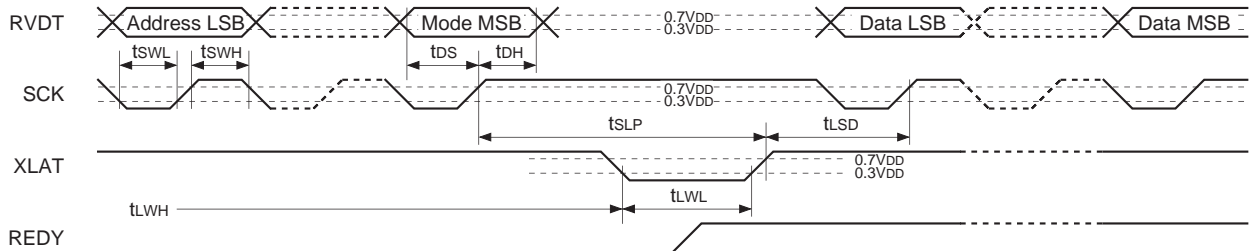

- Transmission timing from data section MSB to address section and transmission mode section

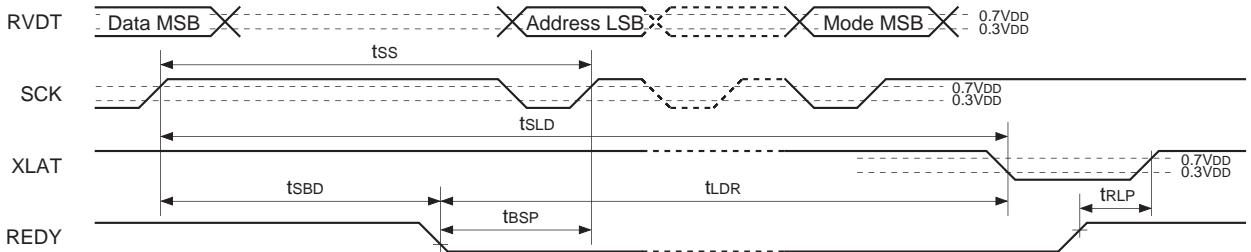

[Read]

- Transmission timing for address section and transmission mode section is the same as for write.

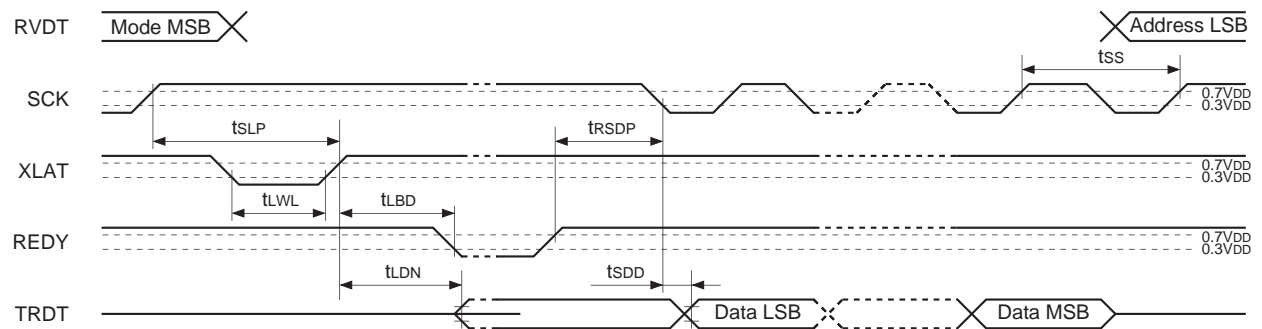

| Item | Symbol | Min. | Max. | Unit |
|---|-------------------|---------|---------|------|
| RVDT setup time relative to SCK rise | t _{DS} | 20 | | ns |
| RVDT data hold time from SCK rise | t _{DH} | 1t + 20 | | ns |
| SCK Low level width | t _{SWL} | 1t + 20 | | ns |
| SCK High level width | t _{SWH} | 1t + 20 | | ns |
| XLAT Low level width | t _{LWL} | 1t + 20 | | ns |
| XLAT High level width | t _{LWH} | 1t + 20 | | ns |
| SCK rise preceding time relative to XLAT rise | t _{SLP} | 20 | | ns |
| SCK rise wait time relative to XLAT rise | t _{LSL} | 3t + 20 | | ns |
| Delay time to REDY fall relative to XLAT rise. | t _{LBD} | | 3t + 50 | ns |
| Delay time to REDY fall relative to SCK rise | t _{SBD} | | 4t + 50 | ns |
| REDY fall preceding time relative to SCK rise | t _{BSP} | 20 | | ns |
| REDY rise preceding time relative to XLAT rise | t _{RLP} | 20 | | ns |
| REDY rise preceding time relative to SCK fall | t _{RSDP} | 20 | | ns |
| XLAT fall wait time relative to SCK rise | t _{SLD} | 3t + 20 | | ns |
| XLAT fall delay time relative to REDY fall | t _{LDR} | 20 | | ns |
| Delay time from XLAT rise until TRDT data becomes active | t _{LDN} | | 3t + 80 | ns |
| Delay time from SCK rise until TRDT data becomes high-impedance | t _{SDF} | | 3t + 80 | ns |
| Delay time from SCK fall until TRDT data is verified | t _{SDD} | | 2t + 70 | ns |
| SCK rise wait time for next transmission | t _{SS} | 2t + 40 | | ns |

Note 1) t is the cycle of 1/2 the clock frequency applied to the XTLL pin. (384fs)

Note 2) REDY and TRDT pins are the values for CL = 60pF.

Analog Characteristics (AV_{D0} to 5 = V_{DD0} to 3 = XV_{DD} = 5.0V, AV_{S0} to 5 = V_{SS0} to 7 = XV_{SS} = 0.0V, T_a = 25°C, DSP: each function = OFF, gain = 1)

[1] ADC + DAC connection total characteristics

The measurement circuit in Figure 1-1 is used. Unless otherwise indicated, the measurement conditions are as given below.

- Input signal ...1.0Vrms, 1kHz
- fs.....44.1kHz
- Rin0Ω

| Item | Measurement conditions | Min. | Typ. | Max. | Unit |
|-----------------------------------|---|------|-------|------|------|
| S/N ratio | 1.0Vrms, EIAJ (with "A" weighting filter) | 80 | 88 | | dB |
| THD + N | 1.0Vrms, EIAJ | | 0.016 | 0.03 | % |
| | 0.5Vrms, EIAJ | | 0.012 | | |
| Dynamic range | EIAJ | | 92 | | dB |
| Channel separation | Only ADC characteristics using DAC1, EIAJ | | 108 | | dB |
| Level difference between channels | Only ADC characteristics using DAC1 | | 0.05 | | dB |
| Analog full-scale input level*1 | Rin = 0Ω | | 1.26 | | Vrms |
| | Rin = 22kΩ | | 2.06 | | |
| ADC input impedance | | | 34.6 | | kΩ |
| Analog current consumption | | | 21 | | mA |

*1 Analog input level which outputs digital full scale.

An optional analog input signal level V_{in} (Vrms) of 1.26Vrms or more can be set in digital full scale by the measurement circuit external resistor R_{in} .

The calculation formula for external resistor R_{in} is:

$$R_{in} = 27.5 \times V_{in} - 34.6 \text{ [k}\Omega\text{]} \dots\dots(1)$$

However, THD + N characteristics deteriorate for full-scale output as shown in Graph 1, so use of up to 80% (when $R_{in} = 0\Omega$, 0.8×1.26 (Vrms) = 1.0 (Vrms) → "analog full scale") of the analog signal level is recommended for digital full-scale output.

In this case, the R_{in} calculation formula is the same as formula (1), except that V_{in} becomes $1.25 \times V_{in}$.

Note that this change causes the output level after ADC + DAC to change.

Most of the above specifications are measurement values for analog full scale.

[2] DAC unit characteristics

Use the measurement circuit in Figure 1-2. Unless otherwise specified, the measurement conditions are as follows.

- Input signal0dB, 1kHz, 16 bits
- fs.....44.1kHz

| Item | Measurement conditions | Min. | Typ. | Max. | Unit |
|-----------------------------------|--------------------------------------|------|-------|------|------|
| S/N ratio | EIAJ (with "A" weighting filter) | | 98 | | dB |
| THD + N | EIAJ (0dB) | | 0.006 | | % |
| | EIAJ (-1dB) | | 0.004 | | |
| Dynamic range | EIAJ (-60dB) | | 98 | | dB |
| Channel separation | EIAJ | | 120 | | dB |
| Level difference between channels | EIAJ | | 0.05 | | dB |
| Output level | EIAJ (Measure at OUT in Figure 1-2.) | | 2.0 | | Vrms |

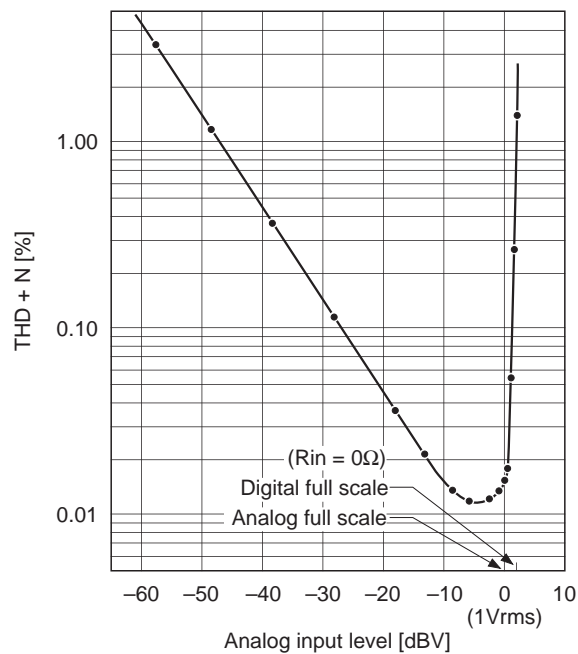

Graph 1.

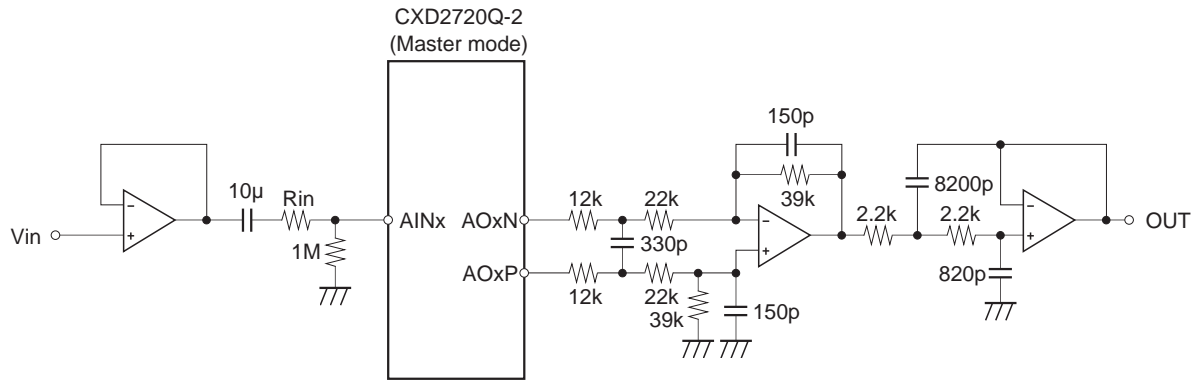

Figure 1-1. ADC + DAC Measurement Circuit Diagram

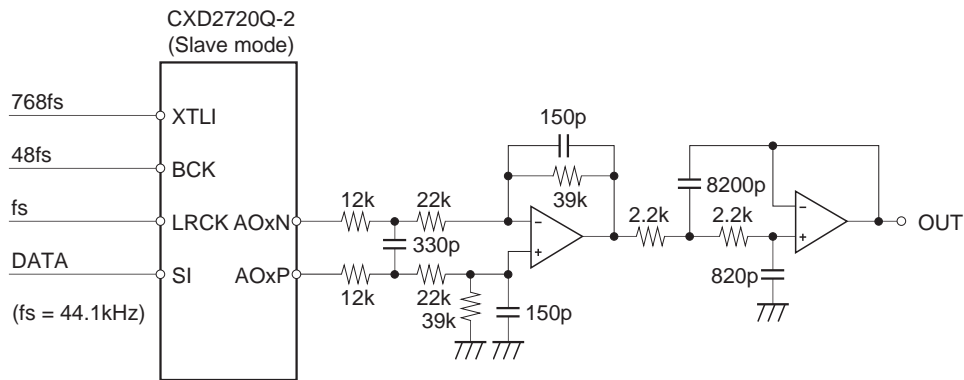

Figure 1-2. DAC Measurement Circuit Diagram

Description of Functions

1. Master/Slave Modes

[Relevant pins] XMST, LRCK, BCK

When connecting multiple CXD2720Q-2s, or when using as a pair with a D/A converter such as the CXD2558M, one of the CXD2720Q-2 should be in master mode to supply LRCK and BCK.

The clock applied to LRCK and BCK in slave mode must be synchronized to either the crystal oscillator clock of the XTLI and XTLO pins or the external clock input from the XTLI pin

| XMST | Mode | LRCK, BCK I/O |
|------|-------------|---------------|
| H | Slave mode | Input |
| L | Master mode | Output |

Table 1-1. LRCK, BCK Mode Setting

2. Master Clock System

[Relevant pins] XTLI, XTLO, BFOT

768fs ($f_s = 44.1\text{kHz}$) is assumed for the master clock system, and the connection is as shown below. (Please inquire with regard to use at other than $f_s = 44.1\text{kHz}$.)

(1) Master

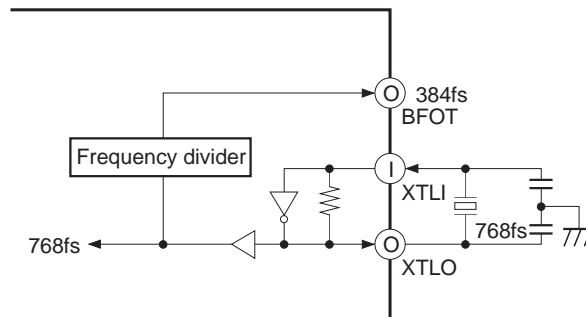

(2) Slave

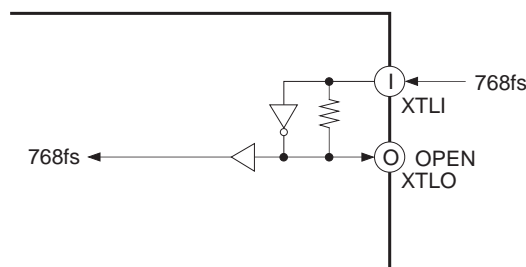

3. Input/Output Synchronization Circuit

[Relevant pins] LRCK, XWO

During normal operation, synchronization is performed automatically to input LRCK (in slave mode), and phase is matched with serial input data, but if there is a lot of jitter on LRCK, or during power input, synchronization may be impossible. In this case, forced synchronization can be done by making the XWO pin Low for 2/Fs or more. Forced synchronization operation is done by the timing of the second LRCK rising edge after the XWO pin is made Low. When synchronization is completed, return the XWO pin to High.

4. Reset Circuit

[Relevant pins] XRST, XTLI, XTLO

This LSI must be reset after power is turned ON.

Reset is done by making the XRST pin Low for 1/Fs or more after supply voltage satisfies the recommended operating condition, and the crystal oscillator clock of the XTLI, XTLO pins or the external clock input from the XTLI pin is correctly applied.

5. Serial Audio Interface (SIF)

[Relevant pins] SI, SO, BCK, LRCK, XS24, XMST

Serial data is used for the external communication of the digital audio data.

The CXD2720Q-2 has one system each for input and output, and each one inputs/outputs 2 channels of data at 1 sampling cycles. Either the 32-bit clock mode or 24-bit clock mode can be selected. In master mode, the 32-bit clock mode is fixed.

(1) Pin Configuration

The pins shown in the table below are assigned to SIF.

| Pin name | I/O | Function |
|----------|-----|--|
| SI | I | Serial input; taken synchronized to BCK. |
| SO | O | Serial output; output synchronized to BCK. |
| BCK | I/O | BCK input/output; either 32-bit clock mode (64fs) or 24-bit clock mode (48fs). BCK output supports 32-bit clock mode only. |
| LRCK | I/O | LRCK input/output (1fs). |
| XS24 | I | SI0 slot number (24/32) selection input. Low: 24-bit slot; High: 32-bit slot. Valid only in slave mode. Set High in master mode. |
| XMST | I | BCK, LRCK master mode/slave mode switching input. Low: master mode; High: slave mode. |

Table 5-1. Pin Configuration

(2) Operation Modes

The LRCK/BCK mode and SI/SO system settings can be selected by the setup register settings as follows.

LRCK/BCK Mode Setting

| Setup register | Function | Contents |
|----------------|--|-------------------------------|
| SQ11 | LRCK format | "0" : normal, "1" : IIS |
| SQ10 | LRCK polarity selection | "0" : Lch High, "1" : Lch Low |
| SQ09 | BCK polarity selection relative to LRCK edge | "0" : edge↓, "1" : edge↑ |

Table 5-2. LRCK/BCK Mode Setting

SI/O System Register Setting

SI system

| Setup register | Function | Contents |
|----------------|----------------------------------|--|
| SQ08 | SI data list | "0" : MSB first, "1" : LSB first |
| SQ07 | SI frontward/rearward truncation | "0" : Forward truncation, "1" : Rearward truncation |
| SQ06 | SI data word length | SQ06 SQ05 |
| SQ05 | SI data word length | 0 0 : 16 bits 1 1 : 24 bits |

Table 5-3. SI System Register Setting

SO system

| Setup register | Function | Contents |
|----------------|--------------------------------|--|
| SQ04 | SO data list | "0" : MSB first, "1" : LSB first |
| SQ03 | SO forward/rearward truncation | "0" : Forward truncation, "1" : Rearward truncation |
| SQ02 | SO data word length | SQ02 SQ01 |
| SQ01 | | 0 0 : 16 bits 0 1 : 18 bits 1 0 : 20 bits 1 1 : 24 bits |

Table 5-4. SO System Register Setting

(3) SIF Format

Serial I/F have one input/output system each, and except for slot number, the following formats can be set independently for input and output, by setting the setup register. It can also be made to support IIS format, to enable connection to Philips and other devices. The timing charts for each data format are given on the following pages.

32-bit slot (XS24 = High)

| SI format | Setup register | SQ05 | SQ06 | SQ07 | SQ08 | Supplement |
|-------------------|---------------------|------|------|------|------|----------------------|
| MSB first 24 bits | Forward truncation | 1 | 1 | 0 | 0 | Supports 20, 16 bits |
| MSB first 16 bits | Rearward truncation | 0 | 0 | 1 | 0 | |
| LSB first 24 bits | Rearward truncation | 1 | 1 | 1 | 1 | Supports 20, 16 bits |

Table 5-5. 32-bit Slot Serial IN

| SO format | Setup register | SQ01 | SQ02 | SQ03 | SQ04 |
|-------------------|---------------------|------|------|------|------|
| MSB first 16 bits | Rearward truncation | 0 | 0 | 1 | 0 |
| MSB first 18 bits | Rearward truncation | 1 | 0 | 1 | 0 |
| MSB first 20 bits | Rearward truncation | 0 | 1 | 1 | 0 |
| MSB first 24 bits | Rearward truncation | 1 | 1 | 1 | 0 |
| MSB first 24 bits | Forward truncation | 1 | 1 | 0 | 0 |
| LSB first 24 bits | Rearward truncation | 1 | 1 | 1 | 1 |

Table 5-6. 32-bit Slot Serial OUT

24-bit slot (XS24 = Low)

| SI format | Setup register | SQ05 | SQ06 | SQ07 | SQ08 | Supplement |
|-------------------|---------------------|------|------|------|------|--|
| MSB first 16 bits | Rearward truncation | 0 | 0 | 1 | 0 | Supports 20, 16 bits for forward truncation |
| MSB first 24 bits | | 1 | 1 | * | 0 | |
| LSB first 24 bits | | 1 | 1 | * | 1 | Supports 20, 16 bits for rearward truncation |

Table 5-7. 24-bit Slot Serial IN

| SO format | Setup register | SQ01 | SQ02 | SQ03 | SQ04 |
|-------------------|---------------------|------|------|------|------|
| MSB first 16 bits | Rearward truncation | 0 | 0 | 1 | 0 |
| MSB first 18 bits | Rearward truncation | 1 | 0 | 1 | 0 |
| MSB first 20 bits | Rearward truncation | 0 | 1 | 1 | 0 |
| MSB first 24 bits | | 1 | 1 | * | 0 |
| LSB first 24 bits | | 1 | 1 | * | 1 |

Table 5-8. 24-bit Slot Serial OUT

Note 1) When performing 20-bit and 16-bit data input in serial IN 24-bit data format, fill the lower 4 and 8 bits with "0", respectively.

Note 2) * means "don't care".

Digital Audio Data Input Timing (with polarities: SQ11 = 0, SQ10 = 0, SQ09 = 0)

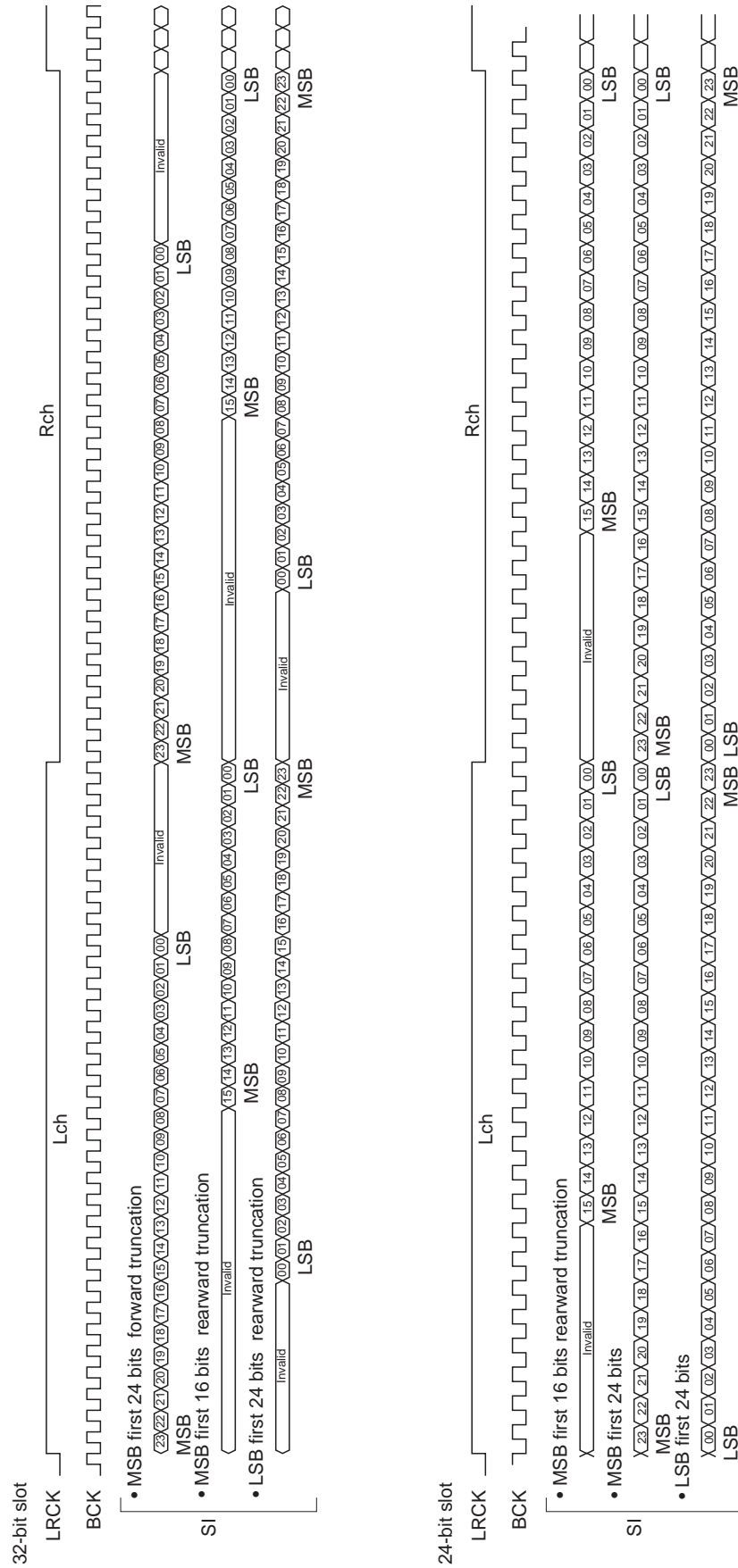

Figure 5-1.

Digital Audio Data Output Timing (with polarities: SQ11 = 0, SQ10 = 0, SQ09 = 0)

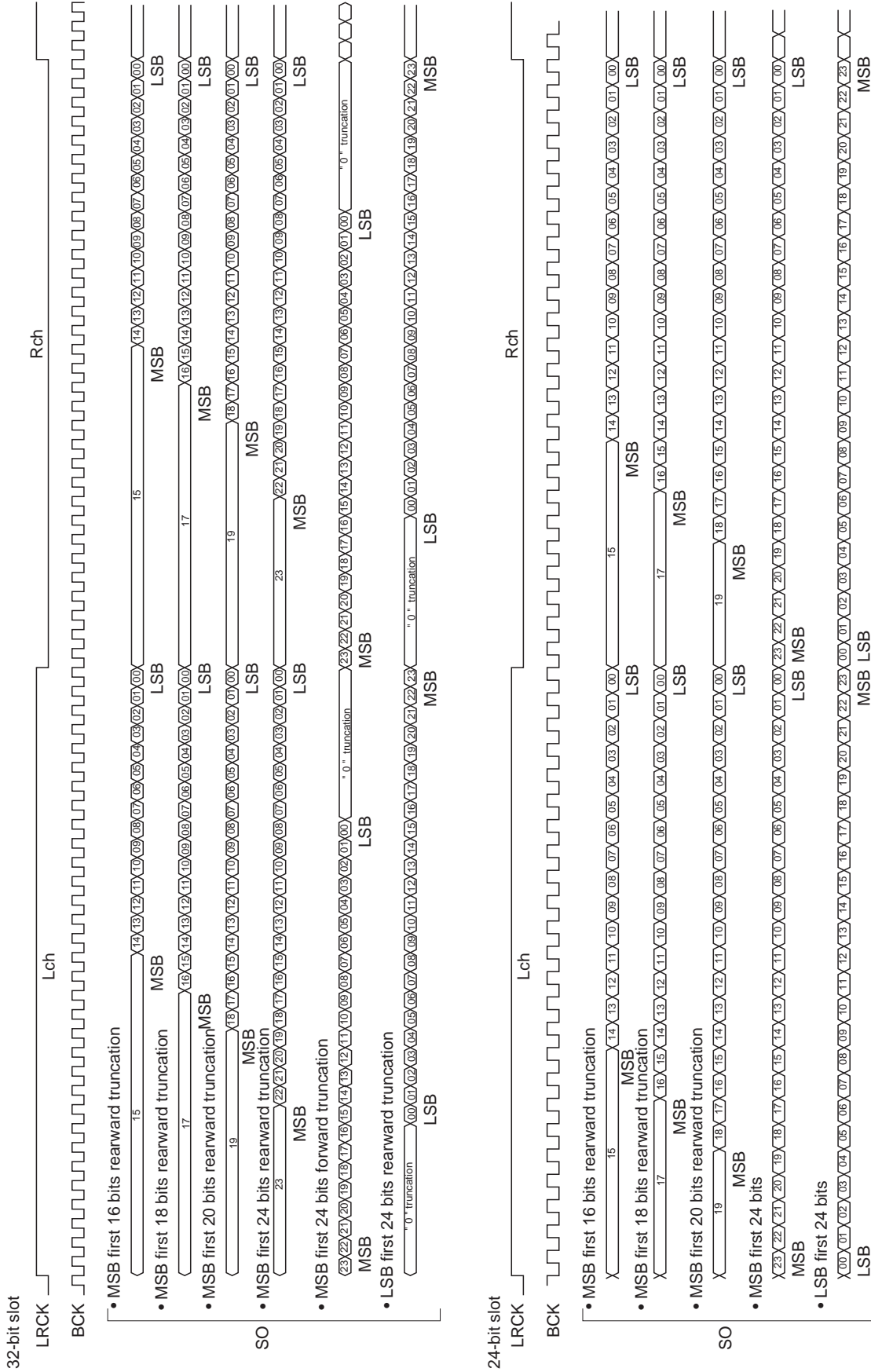

Figure 5-2.

6. Microcomputer Interface

[Relevant pins] RVDT, TRDT, SCK, XLAT, REDY

The CXD2720Q-2 performs serial audio interface format setting, volume, coefficient settings of microphone echo delay amount and others by serial data from the microcomputer.

Further, bidirectional communication such as internal data read from the CXD2720Q-2 to the microcomputer can be done at the rate of once in 1 LRCK.

(1) Pin Structure

The five external pins indicated in the table below are allocated for microcomputer interface.

Microcomputer interface begins operation when XLAT is received, so RVDT, TRDT, SCK and REDY are connected in common, and by controlling (wiring) only XLAT separately, multiple CXD2720Q-2s can be used.

| Pin name | I/O | Function |
|----------|-----|---|
| RVDT | I | Serial data input from microcomputer. |
| TRDT | O | Serial data output to microcomputer. High impedance state unless this pin is set to internal data read state by the microcomputer. Therefore, it is preferable to perform pull-up or pull-down so that potential is not unstable when this pin is not active. |
| SCK | I | Shift clock for serial data. Input data from RVDT is taken according to SCK rise, and output data from TRDT is sent out according to SCK fall. |
| XLAT | I | Interprets the 8 bits of RVDT before this signal rises as transmission mode data, and the bits before that as address data. |
| REDY | O | Transmission prohibited while at Low level. Transmission enabled at High. This pin is an open drain, and must be pulled up externally. |

Table 6-1. Microcomputer Interface External Pins

(2) Description of Communication Formats

The data transmission timing between the microcomputer interface and coefficient RAM and setup register is called the SV cycle, and is generated once in 1LRCK.

The SV cycle is generated immediately preceding the signal processing program, so it has absolutely no effect on signal processing, and there is no risk of the sound being cut.

In read/write modes,

Address section + Mode section + Data section

act as one package of data to perform data transmission between the microcomputer and the CXD2720Q-2.

[Write] • For coefficient RAM

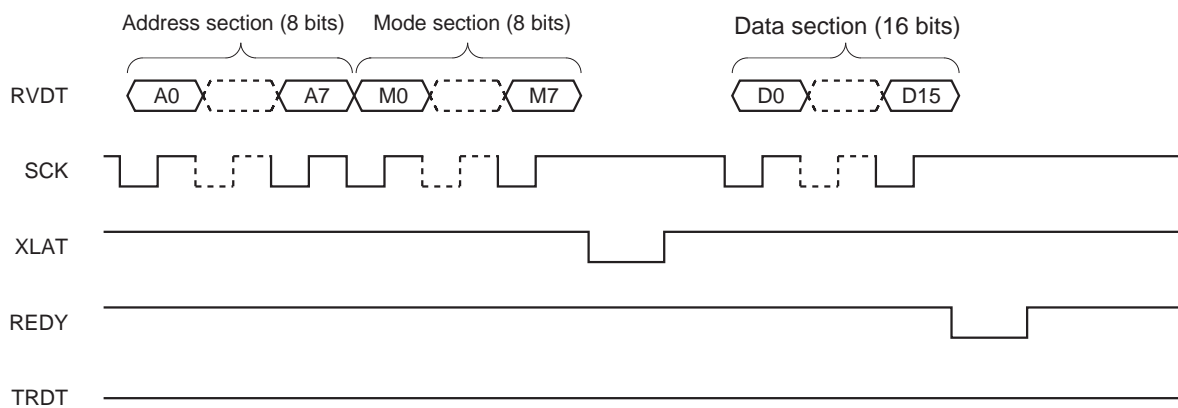

[Read] • For coefficient RAM

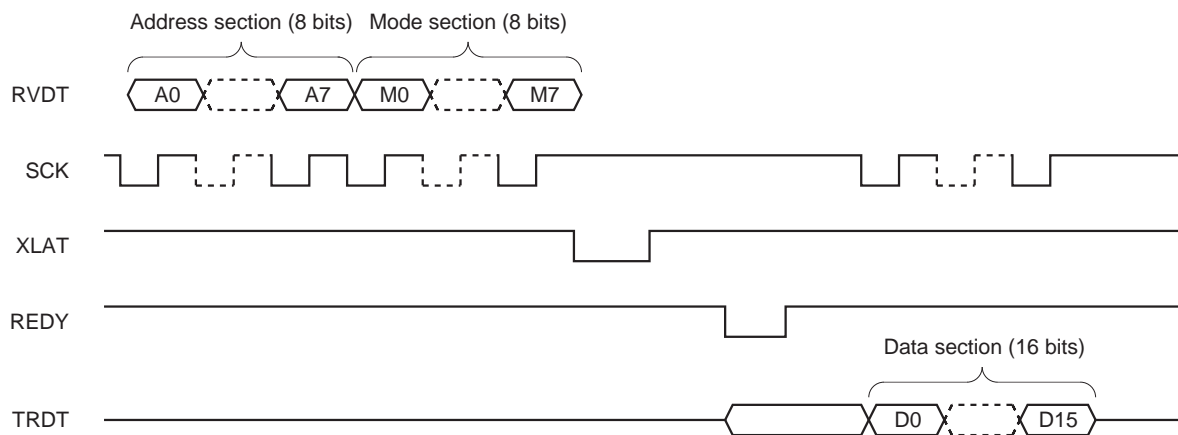

Note) For both read and write, the data section is 24 bits for the setup register.

Figure 6-1. Examples of Communication

(3) Data Structure

Data structure is classified in three types, as shown in the table below. All data communication is done with LSB first.

| Name | Bit length | Contents | Remarks |
|------------------------|------------|---------------------------|---|
| A0 to A7 | 8 | Address section | |
| M0 to M7 | 8 | Transmission mode section | |
| D0 to D15/SQ00 to SQ23 | 16/24 | Data section | Coefficient RAM is 16 bits; setup register is 24 bits |

Table 6-2. Data Structure

(3)-1. Transmission Mode Section

The transmission mode section is 8 bits and has the following functions.

| Bit | Name | Function | | | |
|-----|------|--------------|----------------------------|---|-------------------------|
| M7 | XVMT | SO Mute | 0: ON (No sound) 1: OFF | | |
| M6 | | Reserve | | | |
| M5 | | | | | |
| M4 | VS1 | Data type | VS1 | VS0 | |
| M3 | VS0 | | 0 | 0 | Setup register |
| | | | 1 | 0 | Coefficient RAM (K-RAM) |
| M2 | | Reserve | | | |
| M1 | | | | | |
| M0 | VRD | Send/Receive | 0: Receive 1: Send | Note) Polarity as seen from the CXD2720Q-2 | |

Table 6-3. Transmission Mode Section

(3)-2. Address Section

The coefficient RAM has a 192-word structure, so the address section is 8 bits. The setup register has a 1-word structure, so the address section data may be optional.

(3)-3. Data Section

Sixteen SCK are required, as the coefficient RAM has a 16-bit structure (D0 to D15). The setup register has a 24-bit structure (SQ00 to SQ23), so twenty-four SCK are required.

(4) Details of Communication Methods

The definitions of signal timing required for control from the microcomputer are given below.

(4)-1. Write

First, address section data and mode section data are sent from the microcomputer, synchronized to SCK, to the RVDT pin.

The address section data is 8 bits both for the coefficient RAM and setup register, and the setup register transmits optional data for 1 word length. Address section data is sent with LSB first.

Mode section data is fixed at 8 bits regardless of content.

The phase relationship between SCK and RV data (data applied to the RVDT pin) has the following restrictions:

- RV data must be verified before SCK rise ($t_{bs} \geq 20ns$).
- RV data must be held for $1t + 20ns$ or more after SCK rise (t_{DH}).

SCK itself has the following restrictions:

- SCK Low level must be $1t + 20ns$ or more (t_{SWL}).
- SCK High level must also be $1t + 20ns$ or more (t_{SWH}).

After raising SCK which corresponds to mode section final data, XLAT is raised ($t_{SLP} \geq 20ns$). XLAT Low level width must be maintained at $1t + 20ns$ or more (t_{LWL}). Further, fall timing restrictions are:

- for the preceding transmission, if REDI falls due to SCK, as for write, $3t + 20ns$ or more is required. (t_{SLD})
- for the preceding transmission, if REDI falls due to XLAT, as for read, $20ns$ or more is required. (t_{LDR})

Further, if preceding transmissions have been performed and REDI = Low, it is necessary to wait for REDI = High to raise XLAT.

The procedure until this point is the same for write and read.

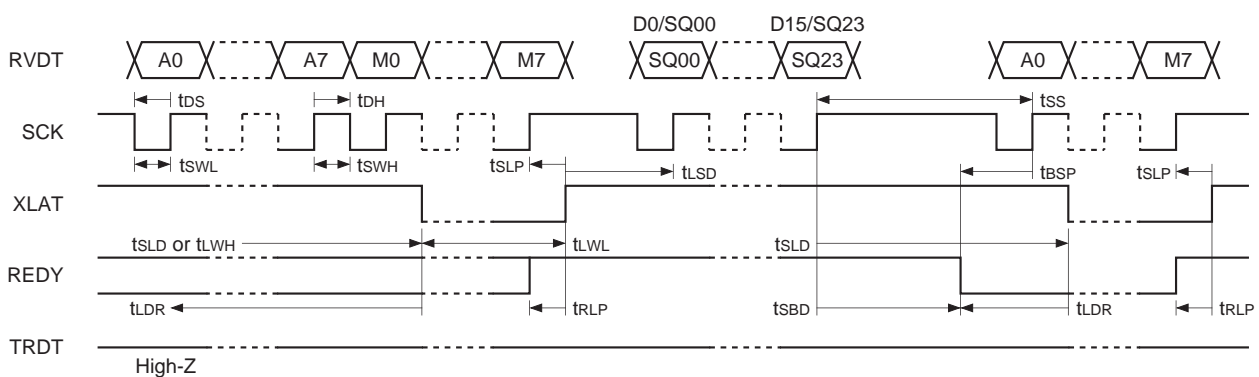

Figure 6-2. Write Timing

Data section write begins after XLAT rise, and here also transmission must be with LSB first, with t_{bs} and t_{DH} restrictions. In addition, after raising XLAT at the starting point for sending to the data section, wait for $3t + 20ns$ or more for the first SCK rise. (t_{LSD})

When 16 bits (coefficient RAM) or 24 bits (setup register) of this write is repeated, REDY = Low within $4t + 50ns$, and the microcomputer is informed of waiting status for the SV cycle, which is the dedicated data rewrite cycle by microcomputer interface. (t_{SBD})

When REDY goes High again, the corresponding data is written.

The next communication restarts by using the REDY signal as follows.

- When REDY = Low, the SCK for the next transmission can rise ($t_{BSP} \geq 20ns$).
- In the same way, when REDY = Low, the XLAT for the next transmission can fall ($t_{LDR} \geq 20ns$).

REDY will fall due to this transmission, but it is prohibited for XLAT to rise for the next transmission before the REDY rises. Be sure to raise the next XLAT after REDY rises ($t_{RLP} \geq 20ns$).

In order to restart the next transmission without using the REDY signal, the following conditions must be observed:

- There should be $2t + 40ns$ or more left between the SCK rise for the final data section and the SCK rise for the next transmission (t_{ss}).
- In the same way, the XLAT for the next transmission can fall after waiting $3t + 20ns$ or more after the final data section SCK rise (t_{SLD}).

The t_{ss} and t_{SLD} here are shorter times than $t_{SBD} \leq 4t + 50ns$, so the restriction conditions are not much strict. However, even in this case the rise of XLAT for the next transmission must come after REDY rise ($t_{RLP} \geq 20ns$).

Further, the restriction for XLAT fall at the starting point of this write from t_{SLD} can be:

- $t_{SLD} \geq 3t + 20ns$ if the preceding transmission was "write".

(4)-2. Read

First, address section and mode section data are transmitted synchronized to SCK, and XLAT is raised matched with this; the procedure until this point is the same as for write, so the description is omitted here.

Read differs from write in that after XLAT rise, REDY falls within $3t + 50\text{ns}$ (t_{LBD}), and the microcomputer is informed of SV cycle waiting.

At this time, the TRDT pin changes from high-impedance state to active state ($t_{\text{LDN}} \leq 3t + 80\text{ns}$) simultaneously with REDY fall. When the read data is ready, the REDY pin changes from Low to High. When the data read out from the TRDT pin is made TR, and SCK falls ($t_{\text{RSDP}} \geq 20\text{ns}$) when the REDY pin goes High, the first TR data is defined within $2t + 70\text{ns}$ (t_{SDD}). The microcomputer reads this data at SCK rise. The TR data is read in order from the LSB with 16 bits for the coefficient RAM and 24 bits for the setup register by adding SCK, the corresponding data is all read, and then read is completed.

Next, the method for restarting transmission after read is completed is described.

As in Case 1, there is a method for sending address section and mode section data consecutively after reading all of the 16- or 24-bit data. There should be $2t + 40\text{ns}$ or more left between the SCK rise for the final data read and the next SCK rise (t_{ss}), and this is established by the conditions $t_{\text{SWL}} \geq 1t + 20\text{ns}$ and $t_{\text{SWH}} \geq 1t + 20\text{ns}$. Further, at this read REDY changes from High to Low, but it is prohibited for the XLAT for the next transmission to fall before this. If REDY = Low has been verified, XLAT can fall ($t_{\text{LDR}} \geq 20\text{ns}$).

Also, while 16- or 24-bit data is being read from the TRDT pin, address and mode section data writing to the RVDT pin for the next transmission can be started.

In Case 3, the final section of read data and the final data in the mode section overlap, and this allows shifting to the next transmission processing in the shortest possible time after data read.

It is also possible to have data read and address and mode section write overlap partially, as shown in Case 2.

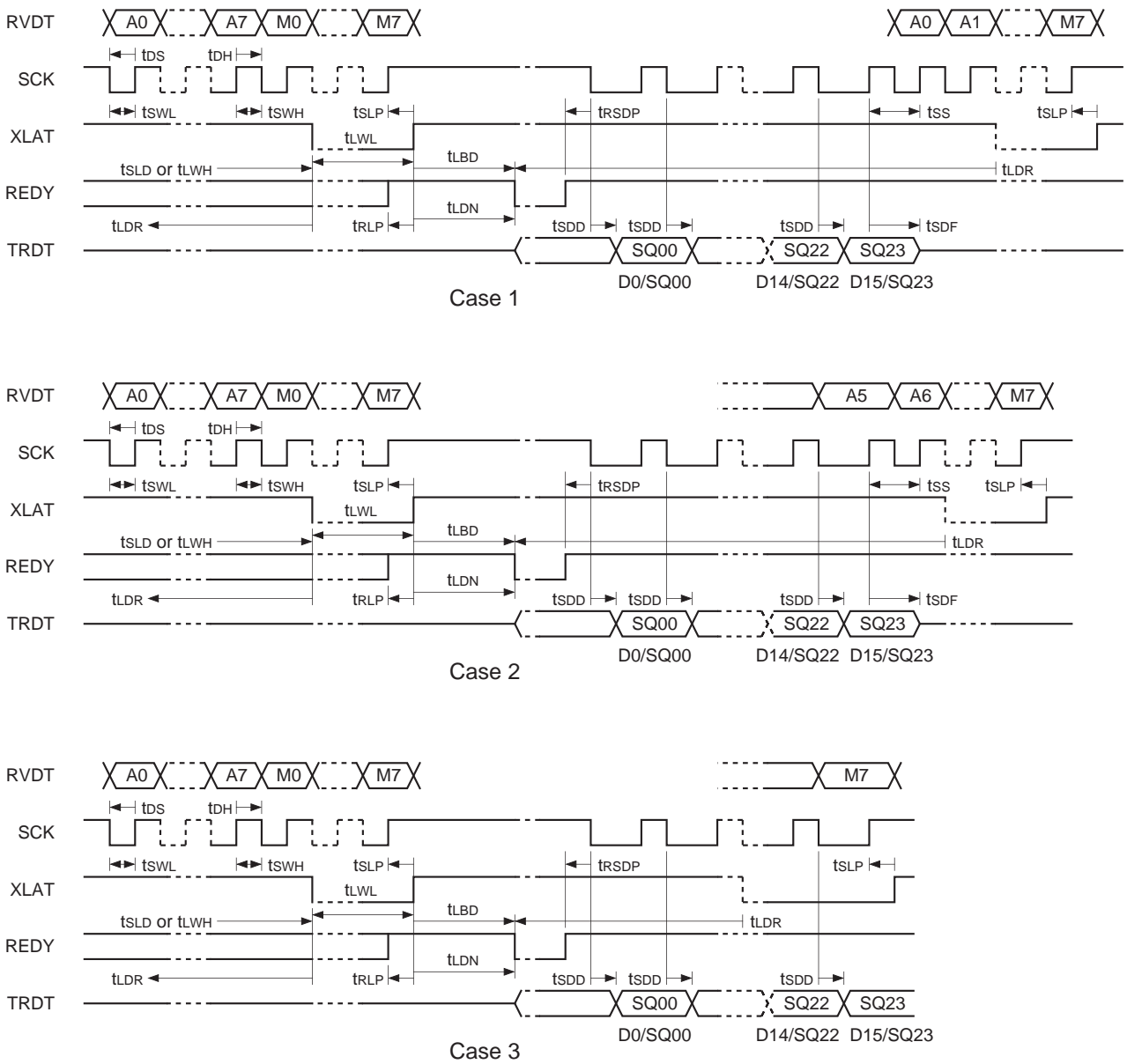

Figure 6-3. Read Timing

7. Setup Register

When the setup register is selected for microcomputer interface transmission mode, the following settings are possible for serial audio interface and DAC.

| Data section bit | Control | | When system reset is Low |
|------------------|--|--|--------------------------|
| SQ23 to 12 | Reserve bit | Must be Low for setup register setting change | All Low |
| SQ11 | LRCK format | 0: normal 1: IIS | Normal |
| SQ10 | LRCK polarity selection | 0: Lch High 1: Lch Low | Lch High |
| SQ09 | BCK polarity selection relative to LRCK edge | 0: Falling edge 1: Rising edge | Falling edge |
| SQ08 | SI data list | 0: MSB first 1: LSB first (24-bit rearward truncation) | MSB first |
| SQ07 | SI frontward/rearward truncation | 0: Frontward truncation (valid only for MSB first/24 bits/32 slots) 1: Rearward truncation | Frontward truncation |
| SQ06, 05 | SI data word length | SQ06 SQ05 0 0 : 16 bits 1 1 : 24 bits | 16 bits |
| SQ04 | SO data list | 0: MSB first 1: LSB first | LSB first |
| SQ03 | SO frontward/rearward truncation | 0: Frontward truncation 1: Rearward truncation | Frontward truncation |
| SQ02, 01 | SO data word length | SQ02 SQ01 0 0 : 16 bits 0 1 : 18 bits 1 0 : 20 bits 1 1 : 24 bits | 16 bits |
| SQ00 | DAC forced mute | 0: ON 1: OFF | ON |

Table 7-1.

8. Coefficient RAM Setting

When the coefficient RAM is selected in microcomputer interface transmission mode, the coefficient parameters such as each section's volumes and microphone echo delay amount can be set. Data settings other than those given following in Tables 8-1 and 8-2 are "don't care".

(1) Fixed Values for System Initialization

When the system is initialized, the coefficient RAM must be set at the fixed values, shown below, for internal operation.

| Address | Fixed value | | | Address | Fixed value | | |
|---------|--------------|------------|------------|---------|--------------|------------|------------|
| | fs = 44.1kHz | fs = 48kHz | fs = 32kHz | | fs = 44.1kHz | fs = 48kHz | fs = 32kHz |
| 01H | 68A9H | 6A30H | 623EH | 36H | 0000H | | |
| 02H | 5121H | 5460H | 447CH | 3BH | 0008H | | |
| 03H | 0000H | | | 43H | 0000H | | |
| 19H | 0000H | | | 46H | 0000H | | |
| 1AH | 0000H | | | 48H | 0001H | | |
| 1BH | 4000H | | | 50H | 0008H | | |
| 1CH | 4000H | | | 72H | 0092H | | |
| 20H | 0010H | | | 73H | 0209H | | |
| 21H | 4000H | | | 74H | 02CDH | | |
| 23H | 4000H | | | 75H | 0109H | | |
| 24H | 1600H | | | 76H | FDA0H | | |
| 25H | 2A00H | | | 77H | FD19H | | |
| 26H | 3FF8H | | | 78H | 0189H | | |
| 27H | 8000H | | | 79H | 058AH | | |
| 28H | 0000H | | | 7AH | 016DH | | |
| 2DH | 0008H | | | 7BH | F7BEH | | |
| 31H | 4000H | | | 7CH | F72AH | | |
| 32H | 1600H | | | 7DH | 0A4EH | | |
| 33H | 2A00H | | | 7EH | 2706H | | |
| 34H | 3FF8H | | | 7FH | 34EEH | | |
| 35H | 8000H | | | | | | |

Table 8-1.

(2) Setting Data

The relationships between the coefficient RAM and each function during DSP operation are as follows.

| Address | Name | Function | Setting value |
|---------|--------|--|---------------------------------|
| 00H | Ki | SI data input level control | Refer to Table 12-1 |
| 04H | Ke | De-emphasis ON/OFF | Refer to Table 9 |
| 05H | DC1a1 | DC cut1 coefficient for accompaniment | Refer to Table 14-1 |
| 06H | DC1a0 | DC cut1 coefficient for accompaniment | Refer to Table 14-1 |
| 07H | DC1b | DC cut1 coefficient for accompaniment | Refer to Table 14-1 |
| 08H | DC2a1 | DC cut2 coefficient for voice | Refer to Table 14-1 |
| 09H | DC2a0 | DC cut2 coefficient for voice | Refer to Table 14-1 |
| 0AH | DC2b | DC cut2 coefficient for voice | Refer to Table 14-1 |
| 0BH | PEQa | PEQ coefficient for voice | Refer to Table 14-3 |
| 0CH | PEQb1 | PEQ coefficient for voice | Refer to Table 14-3 |
| 0DH | PEQb2 | PEQ coefficient for voice | Refer to Table 14-3 |
| 0EH | PEQg | PEQ coefficient for voice | Refer to Table 14-4 |
| 0FH | KisLm | SI CH1 data → Lch mix | Refer to Table 12-1 |
| 10H | KisRc | SI CH2 data → Lch mix | Refer to Table 12-1 |
| 11H | KiaLm | ADC CH1 data → Lch mix | Refer to Table 12-1 |
| 12H | KiaRc | ADC CH2 data → Lch mix | Refer to Table 12-1 |
| 13H | KisRm | SI CH2 data → Rch mix | Refer to Table 12-1 |
| 14H | KisLc | SI CH1 data → Rch mix | Refer to Table 12-1 |
| 15H | KiaRm | ADC CH2 data → Rch mix | Refer to Table 12-1 |
| 16H | KiaLc | ADC CH1 data → Rch mix | Refer to Table 12-1 |
| 17H | KiaML | ADC CH3 (Mic) data → Lch mix | Refer to Table 12-1 |
| 18H | KiaMR | ADC CH3 (Mic) data → Rch mix | Refer to Table 12-1 |
| 1DH | nRpR | Pitch ratio for Lch | Refer to Table 10-1 |
| 1EH | nRpR_R | Pitch ratio for Rch | Refer to Table 10-1 |
| 1FH | Kp | Pitch ratio switching for LR independent/LR common | Common/8000H; independent/0000H |
| 2EH | Ks | Key control ON/OFF | ON/8000H; OFF/0000H |
| 3CH | KLf | Lch IIR4 output mix | Refer to Table 12-1 |
| 3DH | KRf | Rch IIR4 output mix | Refer to Table 12-1 |
| 3EH | KLpc | Lch pitch control output mix | Refer to Table 12-1 |
| 3FH | KRpc | Rch pitch control output mix | Refer to Table 12-1 |
| 40H | KLpt | Lch data → Echo mix | Refer to Table 12-1 |
| 41H | KRpt | Lch data → Echo mix | Refer to Table 12-1 |
| 42H | KdryE | Microphone PEQ output → Echo mix | Refer to Table 12-1 |

Table 8-2 (1). Coefficient RAM Setting Data (1/2)

| Address | Name | Function | Setting value |
|---------|--------|---|---------------------|
| 44H | Tdo | Microphone echo delay amount | Refer to Table 12-1 |
| 45H | Kre | Microphone echo read tap volume | Refer to Table 12-2 |
| 47H | Tre | Microphone echo read tap address | Refer to Table 11-1 |
| 49H | Krd | Microphone echo input sound mix | Refer to Table 12-1 |
| 4AH | Kfb | Microphone echo reverberation sound mix | Refer to Table 12-1 |
| 4BH | HCa1 | Microphone echo high cut | Refer to Table 14-2 |
| 4CH | HCa0 | Microphone echo high cut | Refer to Table 14-2 |
| 4DH | HCb | Microphone echo high cut | Refer to Table 14-2 |
| 51H | KdryL | Microphone input direct sound Lch mix | Refer to Table 12-1 |
| 52H | KdryR | Microphone input direct sound Rch mix | Refer to Table 12-1 |
| 53H | Keff | Microphone input echo mix | Refer to Table 12-1 |
| 54H | KLm | Key control Lch data → Lch mix | Refer to Table 12-1 |
| 55H | KRm | Key control Rch data → Rch mix | Refer to Table 12-1 |
| 56H | KLmc | Key control Rch data → Lch mix | Refer to Table 12-1 |
| 57H | KRmc | Key control Lch data → Rch mix | Refer to Table 12-1 |
| 58H | KLo | System volume Lch | Refer to Table 12-1 |
| 59H | KRo | System volume Rch | Refer to Table 12-1 |
| 5AH | Kmut | Fade in/out Lch and Rch | Refer to Table 12-1 |
| 60H | IIR1a1 | Pitch control input IIR_1 coefficient | Refer to Table 14-5 |
| 61H | IIR1a0 | Pitch control input IIR_1 coefficient | Refer to Table 14-5 |
| 62H | IIR1b | Pitch control input IIR_1 coefficient | Refer to Table 14-5 |
| 63H | IIR2a1 | Pitch control input IIR_2 coefficient | Refer to Table 14-5 |
| 64H | IIR2a0 | Pitch control input IIR_2 coefficient | Refer to Table 14-5 |
| 65H | IIR2b | Pitch control input IIR_2 coefficient | Refer to Table 14-5 |
| 66H | IIR3a1 | IIR_3 coefficient | Refer to Table 14-5 |
| 67H | IIR3a0 | IIR_3 coefficient | Refer to Table 14-5 |
| 68H | IIR3b | IIR_3 coefficient | Refer to Table 14-5 |
| 69H | IIR4a1 | IIR_4 coefficient | Refer to Table 14-5 |
| 6AH | IIR4a0 | IIR_4 coefficient | Refer to Table 14-5 |
| 6BH | IIR4b | IIR_4 coefficient | Refer to Table 14-5 |

Table 8-2. Coefficient RAM Setting Data (2/2)

* Refer to 13. DSP Signal Flow regarding the names.

9. De-emphasis Settings

[Relevant coefficients] Ke (address = 04H)

| | | Ke |
|-----|--------------|-------|
| OFF | | 0000H |
| ON | fs = 44.1kHz | AC19H |
| | fs = 48kHz | AB50H |
| | fs = 32kHz | B01DH |

Table 9. Settings for De-emphasis ON/OFF Coefficients

10. Key Controller Setting

[Relevant coefficients] nRpR (address = 1DH), nRpR_R (address = 1EH), Kp (address = 1FH),
Ks (address = 2EH)

(1) Key Controller Pitch Ratio

nRpR (D15,.....,D2) is a 2's complement format with a decimal point between D14 and D13, and sets the desired pitch ratio directly. (VnRpR has the same type of setting as nRpR.)

$$nRpR = \sum_{n=2}^{15} D_n \times 2^{n-14}$$

The expression range for the pitch ratio is: $-2.0 \leq nRpR \leq 2.0 - 2^{-12}$

but for practical use it is: $-0.5 \leq nRpR \leq 1.0$
or ± 1 octave.

Use within a range of \pm half an octave is recommended for quality of sound, although it depends on the aim and the source.

Also, the algorithm is such that allophones will not be generated even when nRpR setting value is changed. This applies to nRpR_R (Rch pitch ratio).

(2) L/R Common Setting and L/R Independent Setting of Pitch Ratio

The pitch ratio value can be set commonly or independently for Lch and Rch. It is recommended that the common value be set when the key controller is used as the music key controller, and the independent values be set when it is used as the voice effect.

Kp (address = 1FH) is used to switch the settings of the common value and independent values.

The common value is set when Kp is 8000H. nRpR (address = 1DH) is valid, and nRpR_R (address = 1EH) setting value is invalid for both Lch and Rch in the pitch ratio.

The independent values are set when Kp is 0000H. nRpR is valid for Lch, and nRpR_R is valid for Rch in the pitch ratio.

(3) Notes on Key Controller OFF

The pitch does not change when nRpR and nRpR_R are set to 0000H (OFF) when the key controller is OFF, but depending on the internal state during OFF, there is no guarantee that the input value will be output as is. During OFF, after setting nRpR and nRpR_R to 0000H (OFF), set the pitch control section to through state.

(4) Examples of Key Controller Setting

Examples of pitch ratio setting are illustrated below.

nRpR setting values are hexadecimal notation with D15 as MSB and D2 as LSB for a total of 14 bits.
(D1 and D0 can be optional data.)

| CENT | nPpR, nRpR_R | CENT | nPpR, nRpR_R |
|-------|--------------|-------|--------------|
| 0 | 0000H | 0 | 0000H |
| +50 | 01E0H | -50 | FE2EH |
| +100 | 03CEH | -100 | FC69H |
| +150 | 05CAH | -150 | FAB1H |
| +200 | 07D6H | -200 | F905H |
| +250 | 09F1H | -250 | F765H |
| +300 | 0C1BH | -300 | F5D2H |
| +350 | 0E56H | -350 | F44AH |
| +400 | 10A2H | -400 | F2CCH |
| +450 | 12FFH | -450 | F15AH |
| +500 | 156EH | -500 | EFF3H |
| +550 | 17EEH | -550 | EE95H |
| +600 | 1A82H | -600 | ED42H |
| +650 | 1D29H | -650 | EBF8H |
| +700 | 1FE4H | -700 | EAB8H |
| +750 | 22B3H | -750 | E980H |
| +800 | 2597H | -800 | E852H |
| +850 | 2892H | -850 | E72CH |
| +900 | 2BA2H | -900 | E60EH |
| +950 | 2EC9H | -950 | E4F9H |
| +1000 | 3208H | -1000 | E3ECH |
| +1050 | 3560H | -1050 | E2E6H |
| +1100 | 38D0H | -1100 | E1E8H |
| +1150 | 3C5BH | -1150 | E0F1H |
| +1200 | 4000H | -1200 | E000H |

Table 10-1. Pitch Ratio Setting Examples

The numeric representation format for pitch ratio here is:

$$nRpR = \sum_{n=2}^{15} D_n \times 2^{n-14}$$

The numeric representation range is: $-2.0 \leq nRpR \leq 2.0 - 2^{-12}$

Also, the relationship formula with music word cent value C is:

$$nRpR = 2^{\frac{C}{1200}} - 1, C = 1200 \log^2 [nRpR + 1] [\text{cent}]$$

The semitone at average ratio is 100 [cent].

11. Microphone Echo Delay Amount Setting

[Relevant coefficients] Tdo (address = 44H), Tre (address = 47H)

Microphone echo delay amount can be varied by setting coefficient Tdo (12 bits from D14 to D3) values. The relationships between the coefficient and the delay amount differ depending on fs used as shown in Table 11-1.

Coefficient Tre (12 bits from D14 to D3) is microphone input echo initial delay time.
Set in the range of 0008H to Tdo.

| Setting value Tdo | Delay | | |
|-------------------|--------------------|--------------------|--------------------|
| | fs = 44.1kHz | fs = 48kHz | fs = 32kHz |
| ▲ 0008H | ▲ 0.045ms | ▲ 0.042ms | ▲ 0.063ms |
| 0010H | · | · | · |
| 0018H | · | · | · |
| · | · | · | · |
| · | · 0.045ms/step | · 0.042ms/step | · 0.063ms/step |
| · 4096 step | · setting possible | · setting possible | · setting possible |
| · | · | · | · |
| 7ff0H | · | · | · |
| 7ff8H | · | · | · |
| ▼ 0000H | ▼ 185.760ms | ▼ 170.667ms | ▼ 256.000ms |

Table 11-1. Microphone Echo Delay Amount Setting

12. Input/Output Level Settings

[Relevant coefficients] Ki (address = 00H), KisLm (address = 0FH), KisRc (address = 10H), KiaLm (address = 11H), KiaRc (address = 12H), KisRm (address = 13H), KisLc (address = 14H), KiaRm (address = 15H), KiaLc (address = 16H), Kre (address = 45H), Krd (address = 49H), Kfb (address = 4AH), KLf (address = 3CH), KRf (address = 3DH), KLpc (address = 3EH), KRpc (address = 3FH), KLpt (address = 40H), KRpt (address = 41H), KdryE (address = 42H), KdryL (address = 51H), KdryR (address = 52H), Keff (address = 53H), KLM (address = 54H), KRm (address = 55H), KLmc (address = 56H), KRmc (address = 57H), KLo (address = 58H), KRo (address = 59H), Kmut (address = 5AH)

The input/output levels and volumes are 2's complement format with a decimal point between D15 and D14, and hexadecimal notation with D15 as MSB and D0 as LSB.

The coefficient and level relationships are as follows.

| D15 to D0 | Level |
|-----------|----------|
| 8000H | 0dB |
| ↓ | ↓ |
| FFFFH | -90.31dB |
| 0000H | -∞ |

Table 12-1. Input/Output Level Settings (other than Kre)

| D15 to D0 | Level |
|-----------|----------|
| 8000H | +12.04dB |
| ↓ | ↓ |
| FFFFH | -78.27dB |
| 0000H | -∞ |

Table 12-2. Input/Output Level Settings (Kre)

The input/output levels for 8001H to FFFE H are determined by the following formulas.

$$(\text{Coefficient value}) = [(-1) \times D15 + \sum_{n=0}^{14} Dn \times 2^{n-15}] \times (-1) \quad \text{for other than Kre}$$

$$(\text{Coefficient value}) = [(-1) \times D15 + \sum_{n=0}^{14} Dn \times 2^{n-15}] \times (-4) \quad \text{for Kre}$$

$$\text{Input/output level} = 20\log [\text{coefficient value}] \text{ dB}$$

* D15 to D0 are negative values, but the calculation is $(-1) \times (D15 \text{ to } D0)$.

* Kmut is the coefficient of the soft mute.

This approaches the specified value approximately every 45μs.

For example, when the output with its level of 0dB (8000H) is set to OFF (0000H), it takes approximately 1.49s to change from 8000H to 0000H.

13. DSP Signal Flow

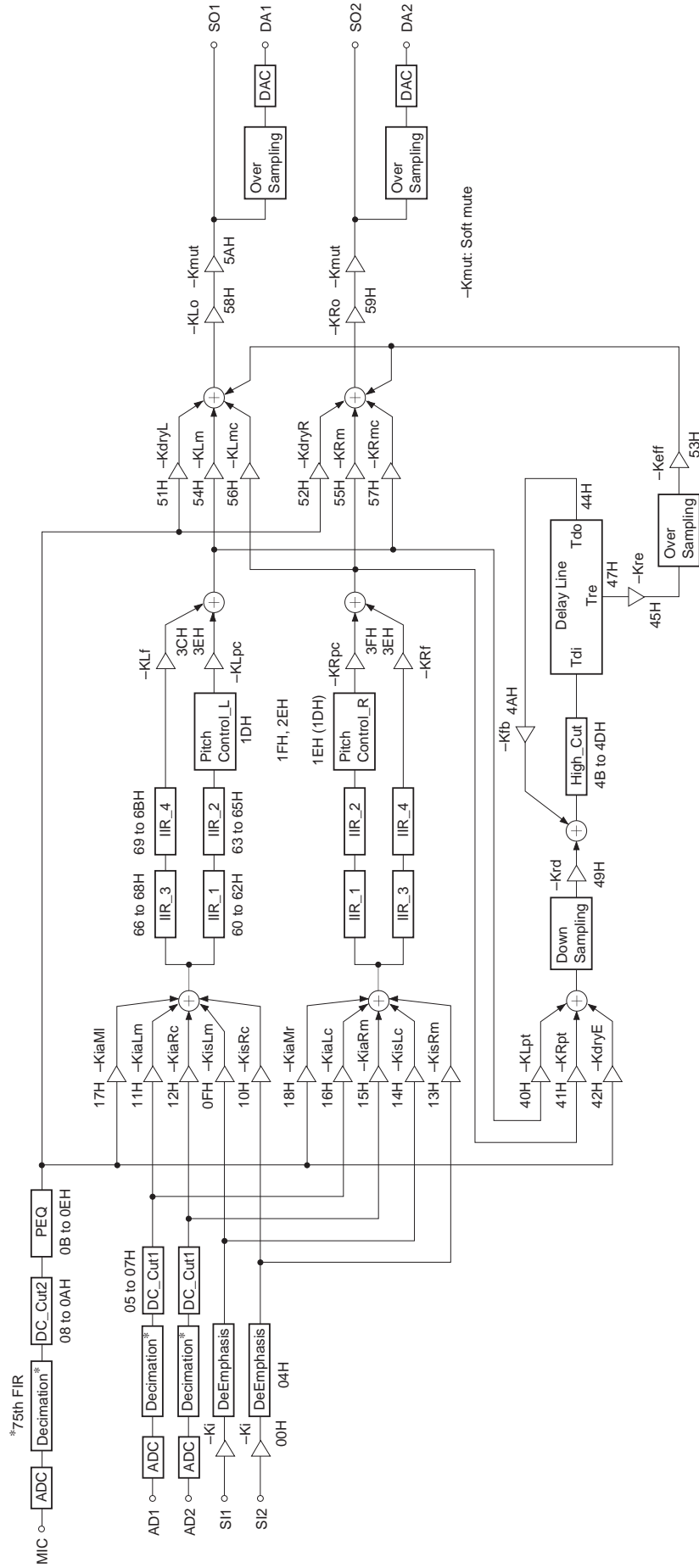

* Refer to the coefficient RAM setting for information on each coefficient.

14. Filter Coefficient Table

[Relevant coefficients] DC1a1 (address = 05H), DC1a0 (address = 06H), DC1b (address = 07H), DC2a1 (address = 08H), DC2a0 (address = 09H), DC2b (address = 0AH), PEQa (address = 0BH), PEQb1 (address = 0CH), PEQb2 (address = 0DH), PEQg (address = 0EH), HCa1 (address = 4BH), HCa0 (address = 4CH), HCb (address = 4DH), IIR*b (address = 62, 65, 68, 6BH), IIR*a1 (address = 60, 63, 66, 69H), IIR*a0 (address = 61, 64, 67, 6AH)

The cut-off frequencies and PEQ gain, Q, and center frequency settings for each signal flow filter are shown in Tables 14-1 (1) to 14-5 (3).

- Note)**
- If the above setting values are changed during DSP operation, the output level becomes unstable for several 1/fs.
 - The coefficients differ depending on fs used. Please inquire with regard to use at fs other than this value.

(1) DC Cut1 for Accompaniment/ DC Cut2 for Voice

| Cut-off frequency (Hz) | DC1a1 DC2a1 | DC1a0 DC2a0 | DC1b DC2b | Cut-off frequency (Hz) | DC1a1 DC2a1 | DC1a0 DC2a0 | DC1b DC2b |
|------------------------|----------------|----------------|--------------|------------------------|----------------|----------------|--------------|
| 20 | 7FD1 | 802F | 7FA2 | 270 | 7D95 | 826B | 7B2B |
| 30 | 7FBA | 8046 | 7F74 | 280 | 7D7F | 8281 | 7AFE |
| 40 | 7FA2 | 805E | 7F45 | 290 | 7D68 | 8298 | 7AD1 |
| 50 | 7F8B | 8075 | 7F17 | 300 | 7D52 | 82AE | 7AA4 |
| 60 | 7F74 | 808C | 7EE9 | 310 | 7D3B | 82C5 | 7A77 |
| 70 | 7F5D | 80A3 | 7EBA | 320 | 7D25 | 82DB | 7A4B |
| 80 | 7F46 | 80BA | 7E8C | 330 | 7D0F | 82F1 | 7A1E |
| 90 | 7F2F | 80D1 | 7E5E | 340 | 7CF8 | 8308 | 79F1 |
| 100 | 7F18 | 80E8 | 7E30 | 350 | 7CE2 | 831E | 79C5 |
| 110 | 7F01 | 80FF | 7E02 | 360 | 7CCC | 8334 | 7998 |
| 120 | 7EEA | 8116 | 7DD4 | 370 | 7CB6 | 834A | 796C |
| 130 | 7ED3 | 812D | 7DA6 | 380 | 7CA0 | 8360 | 7940 |
| 140 | 7EBC | 8144 | 7D78 | 390 | 7C8A | 8376 | 7914 |
| 150 | 7EA5 | 815B | 7D4B | 400 | 7C73 | 838D | 78E7 |
| 160 | 7E8E | 8172 | 7D1D | 410 | 7C5D | 83A3 | 78BB |
| 170 | 7E77 | 8189 | 7CEF | 420 | 7C47 | 83B9 | 788F |
| 180 | 7E61 | 819F | 7CC2 | 430 | 7C31 | 83CF | 7863 |
| 190 | 7E4A | 81B6 | 7C94 | 440 | 7C1B | 83E5 | 7837 |
| 200 | 7E33 | 81CD | 7C67 | 450 | 7C05 | 83FB | 780B |
| 210 | 7E1C | 81E4 | 7C39 | 460 | 7BEF | 8411 | 77DF |
| 220 | 7E06 | 81FA | 7C0C | 470 | 7BDA | 8426 | 77B4 |
| 230 | 7DEF | 8211 | 7BDF | 480 | 7BC4 | 843C | 7788 |
| 240 | 7DD9 | 8227 | 7BB2 | 490 | 7BAE | 8452 | 775C |
| 250 | 7DC2 | 823E | 7B85 | 500 | 7B98 | 8468 | 7731 |
| 260 | 7DAC | 8254 | 7B58 | OFF | 0000 | 8000 | 0000 |

Table 14-1 (1). Coefficients of DC Cut1 for Accompaniment / DC Cut2 for Voice (fs = 44.1kHz)

| Cut-off frequency (Hz) | DC1a1 DC2a1 | DC1a0 DC2a0 | DC1b DC2b | Cut-off frequency (Hz) | DC1a1 DC2a1 | DC1a0 DC2a0 | DC1b DC2b |
|------------------------|-------------|-------------|-----------|------------------------|-------------|-------------|-----------|
| 20 | 7FD5 | 802B | 7FAA | 270 | 7DC6 | 823A | 7B8D |
| 30 | 7FBF | 8041 | 7F7F | 280 | 7DB2 | 824E | 7B64 |
| 40 | 7FAA | 8056 | 7F54 | 290 | 7D9D | 8263 | 7B3B |
| 50 | 7F95 | 806B | 7F2A | 300 | 7D88 | 8278 | 7B11 |
| 60 | 7F7F | 8081 | 7EFF | 310 | 7D74 | 828C | 7AE8 |
| 70 | 7F6A | 8096 | 7ED5 | 320 | 7D5F | 82A1 | 7ABF |
| 80 | 7F55 | 80AB | 7EAA | 330 | 7D4B | 82B5 | 7A96 |
| 90 | 7F40 | 80C0 | 7E80 | 340 | 7D36 | 82CA | 7A6D |
| 100 | 7F2A | 80D6 | 7E55 | 350 | 7D22 | 82DE | 7A44 |
| 110 | 7F15 | 80EB | 7E2B | 360 | 7D0D | 82F3 | 7A1B |
| 120 | 7F00 | 8100 | 7E01 | 370 | 7CF9 | 8307 | 79F2 |
| 130 | 7EEB | 8115 | 7DD7 | 380 | 7CE4 | 831C | 79C9 |
| 140 | 7ED6 | 812A | 7DAC | 390 | 7CD0 | 8330 | 79A0 |
| 150 | 7EC1 | 813F | 7D82 | 400 | 7CBB | 8345 | 7977 |
| 160 | 7EAC | 8154 | 7D58 | 410 | 7CA7 | 8359 | 794E |
| 170 | 7E97 | 8169 | 7D2E | 420 | 7C93 | 836D | 7926 |
| 180 | 7E82 | 817E | 7D04 | 430 | 7C7E | 8382 | 78FD |
| 190 | 7E6D | 8193 | 7CDA | 440 | 7C6A | 8396 | 78D5 |
| 200 | 7E58 | 81A8 | 7CB1 | 450 | 7C56 | 83AA | 78AC |
| 210 | 7E43 | 81BD | 7C87 | 460 | 7C42 | 83BE | 7884 |
| 220 | 7E2E | 81D2 | 7C5D | 470 | 7C2D | 83D3 | 785B |
| 230 | 7E1A | 81E6 | 7C34 | 480 | 7C19 | 83E7 | 7833 |
| 240 | 7E05 | 81FB | 7C0A | 490 | 7C05 | 83FB | 780A |
| 250 | 7DF0 | 8210 | 7BE0 | 500 | 7BF1 | 840F | 77E2 |
| 260 | 7DDB | 8225 | 7BB7 | OFF | 0000 | 8000 | 0000 |

Table 14-1 (2). Coefficients of DC Cut1 for Accompaniment / DC Cut2 for Voice (fs = 48kHz)

| Cut-off frequency (Hz) | DC1a1 DC2a1 | DC1a0 DC2a0 | DC1b DC2b | Cut-off frequency (Hz) | DC1a1 DC2a1 | DC1a0 DC2a0 | DC1b DC2b |
|------------------------|-------------|-------------|-----------|------------------------|-------------|-------------|-----------|
| 20 | 7FBF | 8041 | 7F7F | 270 | 7CB1 | 834F | 7963 |
| 30 | 7F9F | 8061 | 7F3F | 280 | 7C93 | 836D | 7926 |
| 40 | 7F7F | 8081 | 7EFF | 290 | 7C74 | 838C | 78E9 |
| 50 | 7F5F | 80A1 | 7EBF | 300 | 7C56 | 83AA | 78AC |
| 60 | 7F40 | 80C0 | 7E80 | 310 | 7C37 | 83C9 | 786F |
| 70 | 7F20 | 80E0 | 7E40 | 320 | 7C19 | 83E7 | 7833 |
| 80 | 7F00 | 8100 | 7E01 | 330 | 7BFB | 8405 | 77F6 |
| 90 | 7EE0 | 8120 | 7DC1 | 340 | 7BDD | 8423 | 77BA |
| 100 | 7EC1 | 813F | 7D82 | 350 | 7BBF | 8441 | 777E |
| 110 | 7EA1 | 815F | 7D43 | 360 | 7BA0 | 8460 | 7741 |
| 120 | 7E82 | 817E | 7D04 | 370 | 7B82 | 847E | 7705 |
| 130 | 7E63 | 819D | 7CC6 | 380 | 7B64 | 849C | 76C9 |
| 140 | 7E43 | 81BD | 7C87 | 390 | 7B47 | 84B9 | 768E |
| 150 | 7E24 | 81DC | 7C48 | 400 | 7B29 | 84D7 | 7652 |
| 160 | 7E05 | 81FB | 7C0A | 410 | 7B0B | 84F5 | 7616 |
| 170 | 7DE6 | 821A | 7BCC | 420 | 7AED | 8513 | 75DB |
| 180 | 7DC6 | 823A | 7B8D | 430 | 7ACF | 8531 | 759F |
| 190 | 7DA7 | 8259 | 7B4F | 440 | 7AB2 | 854E | 7564 |
| 200 | 7D88 | 8278 | 7B11 | 450 | 7A94 | 856C | 7529 |
| 210 | 7D69 | 8297 | 7AD3 | 460 | 7A77 | 8589 | 74EE |
| 220 | 7D4B | 82B5 | 7A96 | 470 | 7A59 | 85A7 | 74B3 |
| 230 | 7D2C | 82D4 | 7A58 | 480 | 7A3C | 85C4 | 7478 |
| 240 | 7D0D | 82F3 | 7A1B | 490 | 7A1E | 85E2 | 743D |
| 250 | 7CEE | 8312 | 79DD | 500 | 7A01 | 85FF | 7403 |
| 260 | 7CD0 | 8330 | 79A0 | OFF | 0000 | 8000 | 0000 |

Table 14-1 (3). Coefficients of DC Cut1 for Accompaniment / DC Cut2 for Voice (fs = 32kHz)

(2) Microphone Echo High Cut

| Cut-off frequency (Hz) | HCa1 | HCa0 | HCb | Cut-off frequency (Hz) | HCa1 | HCa0 | HCb |
|------------------------|------|------|------|------------------------|------|------|------|
| 1000 | 100E | EFF2 | 5FE2 | 5600 | 40CC | BF34 | FE68 |
| 1100 | 1177 | EE89 | SD11 | 5700 | 41B5 | BE4B | FC95 |
| 1200 | 12D8 | ED28 | SA4E | 5800 | 429F | BD61 | FAC2 |
| 1300 | 1432 | EBCE | 579A | 5900 | 4389 | BC77 | F8EE |
| 1400 | 1586 | EA7A | 54F3 | 6000 | 4173 | BB8D | F719 |
| 1500 | 16D3 | E92D | 5259 | 6100 | 455E | BAA2 | F543 |
| 1600 | 181A | E7E6 | 4FCB | 6200 | 464A | B9B6 | F36C |
| 1700 | 195B | E6A5 | 4D48 | 6300 | 4136 | B8CA | F194 |
| 1800 | 1A97 | E569 | 4AD0 | 6400 | 4822 | B7DE | EFBB |
| 1900 | 1BCE | E432 | 4863 | 6500 | 4910 | B6F0 | EDE0 |
| 2000 | 1CFF | E301 | 4600 | 6600 | 49FF | B601 | EC02 |
| 2100 | 1E2C | E1D4 | 43A6 | 6700 | 4AEE | B512 | EA23 |
| 2200 | 1F55 | E0AB | 4155 | 6800 | 4BDF | B421 | E841 |
| 2300 | 2079 | DF87 | 3F0D | 6900 | 4CD1 | B32F | E65D |
| 2400 | 2199 | DE67 | 3CCD | 7000 | 4DC5 | B23B | E476 |
| 2500 | 22B5 | DD4B | 3A94 | 7100 | 4EBA | B146 | E28C |
| 2600 | 23CE | DC32 | 3863 | 7200 | 4FB0 | B050 | E09F |
| 2700 | 24E3 | DB1D | 3639 | 7300 | 50A9 | AF57 | DEAE |
| 2800 | 25F4 | DA0C | 3416 | 7400 | 51A3 | AE5D | DCBA |
| 2900 | 2703 | D8FD | 31F9 | 7500 | 529F | AD61 | DAC1 |
| 3000 | 280E | D7F2 | 2FE2 | 7600 | 539D | AC63 | D8C5 |
| 3100 | 2917 | D6E9 | 2DD0 | 7700 | 549E | AB62 | D6C4 |
| 3200 | 2A1D | D5E3 | 2BC4 | 7800 | 55A1 | AA5F | D4BE |
| 3300 | 2B21 | D4DF | 29BD | 7900 | 56A6 | A95A | D2B3 |
| 3400 | 2C22 | D3DE | 27BB | 8000 | 57AE | A852 | D0A3 |
| 3500 | 2D21 | D2DF | 25BD | 8100 | 58B9 | A747 | CE8E |
| 3600 | 2E1D | D1E3 | 23C4 | 8200 | 59C7 | A639 | CC72 |
| 3700 | 2F18 | D0E8 | 21CF | 8300 | 5AD8 | A528 | CA50 |
| 3800 | 3011 | CFEF | 1FDD | 8400 | 5BEC | A414 | C828 |
| 3900 | 3108 | CEF8 | 1DEF | 8500 | 5D03 | A2FD | C5F9 |
| 4000 | 31FD | CE03 | 1C04 | 8600 | 5E1F | A1E1 | C3C2 |
| 4100 | 32F1 | CD0F | 1A1C | 8700 | 5F3E | A0C2 | C184 |
| 4200 | 33E3 | CC1D | 1838 | 8800 | 6061 | 9F9F | BF3E |
| 4300 | 34D5 | CB2B | 1655 | 8900 | 6188 | 9E78 | BCEF |
| 4400 | 35C5 | CA3B | 1475 | 9000 | 62B4 | 9D4C | BA98 |
| 4500 | 36B3 | C94D | 1298 | 9100 | 63E4 | 9C1C | B837 |
| 4600 | 37A1 | C85F | 10BC | 9200 | 651A | 9AE6 | B5CC |
| 4700 | 388E | C772 | 0EE2 | 9300 | 6654 | 99AC | B357 |
| 4800 | 397B | C685 | 0D09 | 9400 | 6794 | 986C | B0D7 |
| 4900 | 3A66 | C59A | 0B32 | 9500 | 68DA | 9726 | AE4C |
| 5000 | 3B51 | C4AF | 095C | 9600 | 6A25 | 95DB | ABB5 |
| 5100 | 3C3B | C3C5 | 0788 | 9700 | 6B77 | 9489 | A911 |
| 5200 | 3D26 | C2DA | 05B3 | 9800 | 6CD0 | 9330 | A660 |
| 5300 | 3E0F | C1F1 | 03E0 | 9900 | 6E2F | 91D1 | A3A1 |
| 5400 | 3EF9 | C107 | 020D | 10000 | 6F96 | 906A | A0D4 |
| 5500 | 3FE2 | C01E | 003A | OFF | 0000 | 8000 | 0000 |

Table 14-2 (1). Coefficients of Microphone Echo High Cut (fs = 44.1kHz)

| Cut-off frequency (Hz) | HCa1 | HCa0 | HCb | Cut-off frequency (Hz) | HCa1 | HCa0 | HCb |
|------------------------|------|------|------|------------------------|------|------|------|
| 1000 | 0EE4 | F11C | 6237 | 5600 | 3CA5 | C35B | 06B5 |
| 1100 | 1035 | EFCB | 5F95 | 5700 | 3D7C | C284 | 0507 |
| 1200 | 1180 | EE80 | 5CFF | 5800 | 3E52 | C1AE | 035A |
| 1300 | 12C4 | ED3C | 5A76 | 5900 | 3F29 | C0D7 | 01AC |
| 1400 | 1403 | EBFD | 57F8 | 6000 | 4000 | C000 | 0000 |
| 1500 | 153C | EAC4 | 5586 | 6100 | 40D6 | BF2A | FE54 |
| 1600 | 1670 | E990 | 531F | 6200 | 41AD | BE53 | FCA6 |
| 1700 | 179E | E862 | 50C3 | 6300 | 4283 | BD7D | FAF9 |
| 1800 | 18C7 | E739 | 4E70 | 6400 | 435A | BCA6 | F94B |
| 1900 | 19EC | E614 | 4C26 | 6500 | 4431 | BBCF | F79D |
| 2000 | 1B0C | E4F4 | 49E6 | 6600 | 4509 | BAF7 | F5EE |
| 2100 | 1C28 | E3D8 | 47AE | 6700 | 45E1 | BA1F | F43E |
| 2200 | 1D40 | E2C0 | 457F | 6800 | 46BA | B946 | F28C |
| 2300 | 1E53 | EIAD | 4358 | 6900 | 4793 | B86D | F0DA |
| 2400 | 1F63 | E09D | 4138 | 7000 | 486C | B794 | EF27 |
| 2500 | 2070 | DF90 | 3F1F | 7100 | 4947 | B6B9 | ED71 |
| 2600 | 2179 | DE87 | 3D0D | 7200 | 4A22 | B5DE | EBBB |
| 2700 | 227E | DD82 | 3B02 | 7300 | 4AFF | B501 | EA02 |
| 2800 | 2381 | DC7F | 38FD | 7400 | 4BDC | B424 | E847 |
| 2900 | 2480 | DB80 | 36FE | 7500 | 4CBA | B346 | E68B |
| 3000 | 257D | DA83 | 3504 | 7600 | 4D9A | B266 | E4CB |
| 3100 | 2677 | D989 | 3311 | 7700 | 4E7B | B185 | E30A |
| 3200 | 276E | D892 | 3122 | 7800 | 4F5D | B0A3 | E146 |
| 3300 | 2863 | D79D | 2F38 | 7900 | 5041 | AFBF | DF7E |
| 3400 | 2956 | D6AA | 2D53 | 8000 | 5126 | AEDA | DDB4 |
| 3500 | 2A46 | D5BA | 2B73 | 8100 | 520C | ADF4 | DBE7 |
| 3600 | 2B34 | D4CC | 2996 | 8200 | 52F5 | AD0B | DA16 |
| 3700 | 2C20 | D3E0 | 27BE | 8300 | 53DF | AC21 | D842 |
| 3800 | 2D0A | D2F6 | 25EA | 8400 | 54CB | AB35 | D66A |
| 3900 | 2DF3 | D20D | 2419 | 8500 | SSB9 | AA47 | D18D |
| 4000 | 2ED9 | D127 | 224C | 8600 | 56A9 | A957 | D2AD |
| 4100 | 2FBE | D042 | 2082 | 8700 | 579C | A864 | D0C8 |
| 4200 | 30A2 | CF5E | 1EBA | 8800 | 5891 | A76F | CEDE |
| 4300 | 3184 | CE7C | 1CF6 | 8900 | 5988 | A678 | CCEF |
| 4400 | 3265 | CD9B | 1B35 | 9000 | 5A82 | A57E | CAFC |
| 4500 | 3345 | CCBB | 1975 | 9100 | 5B7F | A481 | C902 |
| 4600 | 3423 | CBDD | 17B9 | 9200 | 5C7E | A382 | C703 |
| 4700 | 3500 | CB00 | 15FE | 9300 | 5D81 | A27F | C4FE |
| 4800 | 35DD | CA23 | 1445 | 9400 | 5E86 | A17A | C2F3 |
| 4900 | 36B8 | C948 | 128F | 9500 | 5F8F | A071 | C0E1 |
| 5000 | 3793 | C86D | 10D9 | 9600 | 609C | 9F64 | BEC8 |
| 5100 | 386C | C794 | 0F26 | 9700 | 61AC | 9E54 | BCA8 |
| 5200 | 3945 | C6BB | 0D74 | 9800 | 62BF | 9D41 | BA81 |
| 5300 | 3A1E | C5E2 | 0BC2 | 9900 | 63D7 | 9C29 | B852 |
| 5400 | 3AF6 | C50A | 0A12 | 10000 | 64F3 | 9B0D | B61A |
| 5500 | 3BCE | C432 | 0863 | OFF | 0000 | 8000 | 0000 |

Table 14-2 (2). Coefficients of Microphone Echo High Cut (fs = 48kHz)

| Cut-off frequency (Hz) | HCa1 | HCa0 | HCb | Cut-off frequency (Hz) | HCa1 | HCa0 | HCb |
|------------------------|------|------|------|------------------------|------|------|------|
| 1000 | 153C | EAC4 | 5586 | 5600 | 54CB | AB35 | D66A |
| 1100 | 1707 | E8F9 | 51F0 | 5700 | 5631 | A9CF | D39E |
| 1200 | 18C7 | E739 | 4E70 | 5800 | 579C | A864 | D0C8 |
| 1300 | 1A7D | E583 | 4B05 | 5900 | 590C | A6F4 | CDE7 |
| 1400 | 1C28 | E3D8 | 47AE | 6000 | 5A82 | A57E | CAFC |
| 1500 | 1DCA | E236 | 446A | 6100 | 5BFE | A402 | C803 |
| 1600 | 1F63 | E09D | 4138 | 6200 | 5D81 | A27F | C4FE |
| 1700 | 20F5 | DF0B | 3E15 | 6300 | 5F0A | A0F6 | C1EB |
| 1800 | 227E | DD82 | 3B02 | 6400 | 609C | 9F64 | BEC8 |
| 1900 | 2401 | DBFF | 37FD | 6500 | 6235 | 9DCB | BB96 |
| 2000 | 257D | DA83 | 3504 | 6600 | 63D7 | 9C29 | B852 |
| 2100 | 26F3 | D90D | 3219 | 6700 | 6582 | 9A7E | B4FB |
| 2200 | 2863 | D79D | 2F38 | 6800 | 6738 | 98C8 | B190 |
| 2300 | 29CE | D632 | 2C62 | 6900 | 68F8 | 9708 | AE10 |
| 2400 | 2B34 | D4CC | 2996 | 7000 | 6AC3 | 953D | AA7A |
| 2500 | 2C95 | D36B | 26D4 | 7100 | 6C9B | 9365 | A6CA |
| 2600 | 2DF3 | D20D | 2419 | 7200 | 6E7F | 9181 | A301 |
| 2700 | 2F4C | D0B4 | 2166 | 7300 | 7072 | 8F8E | 9F1C |
| 2800 | 30A2 | CF5E | 1EBA | 7400 | 7274 | 8D8C | 9B18 |
| 2900 | 31F5 | CE0B | 1C15 | 7500 | 7486 | 8B7A | 96F4 |
| 3000 | 3345 | CCBB | 1975 | 7600 | 76A9 | 8957 | 92AE |
| 3100 | 3492 | CB6E | 16DB | 7700 | 78DF | 8721 | 8E42 |
| 3200 | 35DD | CA23 | 1445 | 7800 | 7B29 | 84D7 | 89AE |
| 3300 | 3725 | C8DB | 11B4 | 7900 | 7D88 | 8278 | 84EF |
| 3400 | 386C | C794 | 0F26 | 8000 | 7FFF | 8001 | 8001 |
| 3500 | 39B2 | C64E | 0C9B | 8100 | 8290 | 7D70 | 7AE0 |
| 3600 | 3AF6 | C50A | 0A12 | 8200 | 853C | 7AC4 | 7588 |
| 3700 | 3C39 | C3C7 | 078C | 8300 | 8805 | 77FB | 6FF5 |
| 3800 | 3D7C | C284 | 0507 | 8400 | 8AEF | 7511 | 6A22 |
| 3900 | 3EBE | C142 | 0283 | 8500 | 8DFB | 7205 | 6409 |
| 4000 | 4000 | C000 | 0000 | 8600 | 912F | 6ED1 | 5DA2 |
| 4100 | 4141 | BEBF | FD7D | 8700 | 948B | 6B75 | 56E9 |
| 4200 | 4283 | BD7D | FAF9 | 8800 | 9816 | 67EA | 4FD3 |
| 4300 | 43C6 | BC3A | F874 | 8900 | 9BD3 | 642D | 4859 |
| 4400 | 4509 | BAF7 | F5EE | 9000 | 9FC8 | 6038 | 4070 |
| 4500 | 464D | B9B3 | F365 | 9100 | A3FA | 5C06 | 380C |
| 4600 | 4793 | B86D | F0DA | 9200 | A870 | 5790 | 2F20 |
| 4700 | 48DA | B726 | EE4C | 9300 | AD31 | 52CF | 259D |
| 4800 | 4A22 | B5DE | EBBB | 9400 | B247 | 4DB9 | 1B71 |
| 4900 | 4B6D | B493 | E925 | 9500 | B7BC | 4844 | 1088 |
| 5000 | 4CBA | B346 | E68B | 9600 | BD9B | 4265 | 04CA |
| 5100 | 4E0A | B1F6 | E3EB | 9700 | C3F3 | 3C0D | F81A |
| 5200 | 4F5D | B0A3 | E146 | 9800 | CAD3 | 352D | EA59 |
| 5300 | 50B3 | AF4D | DE9A | 9900 | D250 | 2DB0 | DB5F |
| 5400 | 520C | ADF4 | DBE7 | 10000 | DA82 | 257E | CAFC |
| 5500 | 536A | AC96 | D92C | OFF | 0000 | 8000 | 0000 |

Table 14-2 (3). Coefficients of Microphone Echo High Cut (fs = 32kHz)

(3) PEQ for Voice

| Center frequency (Hz) | PEQa | PEQb1 | PEQb2 |
|-----------------------|------|-------|-------|
| 250.0 | 023D | 7DAE | 847B |
| 280.6 | 0282 | 7D64 | 8505 |
| 315.0 | 02CF | 7D10 | 859F |
| 353.6 | 0325 | 7CB2 | 864B |
| 396.9 | 0385 | 7C47 | 870B |
| 445.4 | 03F0 | 7BCF | 87E1 |
| 500.0 | 0467 | 7B48 | 88CF |
| 561.2 | 04EC | 7AAE | 89D9 |
| 630.0 | 0580 | 7A01 | 8B01 |
| 707.1 | 0624 | 793D | 8C4A |
| 793.7 | 06DB | 785E | 8DB7 |
| 890.9 | 07A6 | 7762 | 8F4D |
| 1000.0 | 0886 | 7643 | 910E |
| 1122.5 | 097E | 74FD | 92FE |
| 1259.9 | 0A91 | 738B | 9524 |
| 1414.2 | 0BC0 | 71E5 | 9781 |
| 1587.4 | 0D0D | 7004 | 9A1C |
| 1781.8 | 0E7C | 6DE0 | 9CFA |
| 2000.0 | 100E | 6B6D | A01E |
| 2244.9 | 11C7 | 68A1 | A38F |
| 2519.8 | 13A8 | 656E | A752 |
| 2828.4 | 15B5 | 61C6 | AB6C |
| 3174.8 | 17F1 | 5D97 | AFE4 |
| 3563.6 | 1A5E | 58CF | B4BE |
| 4000.0 | 1CFF | 535A | BA00 |
| 4489.8 | 1FD8 | 4D24 | BFB2 |
| 5039.7 | 22ED | 4617 | C5DC |
| 5656.9 | 2642 | 3E23 | CC85 |
| 6349.6 | 29DB | 353B | D3B8 |
| 7127.2 | 2DC1 | 2B5C | DB84 |
| 8000.0 | 31FD | 2097 | E3FC |

Table 14-3 (1). Coefficients of PEQ for Voice (fs = 44.1kHz)

| Gain (dB) | PEQg |
|-----------|------|
| 0.0 | 0000 |
| 0.5 | 01E5 |
| 1.0 | 03E7 |
| 1.5 | 0608 |
| 2.0 | 0849 |
| 2.5 | 0AAC |
| 3.0 | 0D33 |
| 3.5 | 0FE1 |
| 4.0 | 12B7 |
| 4.5 | 15B8 |
| 5.0 | 18E7 |
| 5.5 | 1C46 |
| 6.0 | 1FD9 |
| 6.5 | 23A1 |
| 7.0 | 27A3 |
| 7.5 | 2BE2 |
| 8.0 | 3061 |
| 8.5 | 3524 |
| 9.0 | 3A30 |
| 9.5 | 3F88 |
| 10.0 | 4531 |
| 10.5 | 4B30 |
| 11.0 | 518A |
| 11.5 | 5844 |
| 12.0 | 5F64 |

Table 14-4.

| Center frequency (Hz) | PEQa | PEQb1 | PEQb2 |
|-----------------------|------|-------|-------|
| 250.0 | 020F | 7DDF | 8420 |
| 280.6 | 024F | 7D9B | 849F |
| 315.0 | 0295 | 7D4E | 852C |
| 353.6 | 02E5 | 7CF8 | 85CB |
| 396.9 | 033D | 7C97 | 867C |
| 445.4 | 03A0 | 7C29 | 8742 |
| 500.0 | 040E | 7BAD | 881E |
| 561.2 | 0489 | 7B21 | 8914 |
| 630.0 | 0512 | 7A82 | 8A25 |
| 707.1 | 05AA | 79CF | 8B55 |
| 793.7 | 0653 | 7904 | 8CA8 |
| 890.9 | 070F | 781E | 8E1F |
| 1000.0 | 07DF | 7719 | 8FC0 |
| 1122.5 | 08C6 | 75F0 | 918D |
| 1259.9 | 09C5 | 749F | 938B |
| 1414.2 | 0ADF | 7320 | 95BF |
| 1587.4 | 0C16 | 716B | 982D |
| 1781.8 | 0D6C | 6F79 | 9AD9 |
| 2000.0 | 0EE4 | 6D41 | 9DC9 |
| 2244.9 | 1080 | 6AB8 | A101 |
| 2519.8 | 1243 | 67D2 | A488 |
| 2828.4 | 1430 | 6181 | A861 |
| 3174.8 | 1649 | 60B6 | AC94 |
| 3563.6 | 1892 | 5C61 | B125 |
| 4000.0 | 1B0C | 576C | B61A |
| 4489.8 | 1DBC | 51C6 | BB7A |
| 5039.7 | 20A5 | 4B58 | C14B |
| 5656.9 | 23CA | 4410 | C795 |
| 6349.6 | 2730 | 3BDC | CE62 |
| 7127.2 | 2ADE | 32B1 | D5BD |
| 8000.0 | 2ED9 | 2893 | DDB4 |

Table 14-3 (2). Coefficients of PEQ for Voice
(fs = 48kHz)

| Center frequency (Hz) | PEQa | PEQb1 | PEQb2 |
|-----------------------|------|-------|-------|
| 250.0 | 0311 | 7CC8 | 8623 |
| 280.6 | 036E | 7C60 | 86DE |
| 315.0 | 03D7 | 7BEC | 87AF |
| 353.6 | 074B | 7B68 | 8898 |
| 396.9 | 04CD | 7AD2 | 899B |
| 445.4 | 055D | 7A2A | 8ABC |
| 500.0 | 05FE | 796B | 8BFD |
| 561.2 | 06B0 | 7892 | 8D62 |
| 630.0 | 0776 | 779D | 8EEE |
| 707.1 | 0852 | 7686 | 90A5 |
| 793.7 | 0945 | 754A | 928B |
| 890.9 | 0A51 | 73E2 | 94A4 |
| 1000.0 | 0B79 | 7248 | 96F4 |
| 1122.5 | 0CC0 | 7075 | 9981 |
| 1259.9 | 0E27 | 6E61 | 9C4F |
| 1414.2 | 0FB1 | 6C01 | 9F64 |
| 1587.4 | 1161 | 694A | A2C3 |
| 1781.8 | 1339 | 662F | A673 |
| 2000.0 | 153C | 62A2 | AA7A |
| 2244.9 | 176D | 5E93 | AEDC |
| 2519.8 | 19CF | 59EF | B39F |
| 2828.4 | 1C64 | 54A3 | B8C9 |
| 3174.8 | 1F30 | 4E99 | BE62 |
| 3563.6 | 2237 | 47BF | C470 |
| 4000.0 | 257D | 4000 | CAFC |
| 4489.8 | 2907 | 374E | D20F |
| 5039.7 | 2CDB | 2DA6 | D9B8 |
| 5656.9 | 3103 | 2312 | E207 |
| 6349.6 | 3589 | 17B5 | EB14 |
| 7127.2 | 3A80 | 0BDA | F502 |
| 8000.0 | 3FFF | 0000 | 0000 |

Table 14-3 (3). Coefficients of PEQ for Voice
(fs = 32kHz)

(4) First-Stage IIR Filter

| Cut-off frequency (Hz) | Used as LPF | | | Used as HPF | | | Cut-off frequency (Hz) | Used as LPF | | | Used as HPF | | |
|------------------------|-------------|--------|-------|-------------|--------|-------|------------------------|-------------|--------|-------|-------------|--------|-------|
| | IIR*a1 | IIR*a0 | IIR*b | IIR*a1 | IIR*a0 | IIR*b | | IIR*a1 | IIR*a0 | IIR*b | IIR*a1 | IIR*a0 | IIR*b |
| 3000 | 16D3 | E92D | 5259 | 96D4 | 96D4 | 5259 | 7100 | 2D9F | D261 | 24C0 | ADA0 | ADA0 | 24C0 |
| 3100 | 1777 | E889 | 5110 | 9778 | 9778 | 5110 | 7200 | 2E1D | D1E3 | 23C4 | AE1E | AE1E | 23C4 |
| 3200 | 181A | E7E6 | 4FCB | 981B | 981B | 4FCB | 7300 | 2E9B | D165 | 22C9 | AE9C | AE9C | 22C9 |
| 3300 | 18BB | E745 | 4E88 | 98BC | 98BC | 4E88 | 7400 | 2F18 | D0E8 | 21CF | AF19 | AF19 | 21CF |
| 3400 | 195B | E6A5 | 4D48 | 995C | 995C | 4D48 | 7500 | 2F95 | D06B | 20D5 | AF96 | AF96 | 20D5 |
| 3500 | 19FA | E606 | 4C0B | 99FB | 99FB | 4C0B | 7600 | 3011 | CFEF | 1FDD | B012 | B012 | 1FDD |
| 3600 | 1A97 | E569 | 4AD0 | 9A98 | 9A98 | 4AD0 | 7700 | 308C | CF74 | 1EE6 | B08D | B08D | 1EE6 |
| 3700 | 1B33 | E4CD | 4998 | 9B34 | 9B34 | 4998 | 7800 | 3108 | CEF8 | 1DEF | B109 | B109 | 1DEF |
| 3800 | 1BCE | E432 | 4863 | 9BCF | 9BCF | 4863 | 7900 | 3183 | CE7D | 1CF9 | B184 | B184 | 1CF9 |
| 3900 | 1C67 | E399 | 4730 | 9C68 | 9C68 | 4730 | 8000 | 31FD | CE03 | 1C04 | B1FE | B1FE | 1C04 |
| 4000 | 1CFF | E301 | 4600 | 9D00 | 9D00 | 4600 | 8100 | 3277 | CD89 | 1B10 | B278 | B278 | 1B10 |
| 4100 | 1D96 | E26A | 44D2 | 9D97 | 9D97 | 44D2 | 8200 | 32F1 | CD0F | 1A1C | B2F2 | B2F2 | 1A1C |
| 4200 | 1E2C | E1D4 | 43A6 | 9E2D | 9E2D | 43A6 | 8300 | 336A | CC96 | 192A | B36B | B36B | 192A |
| 4300 | 1EC1 | E13F | 427C | 9EC2 | 9EC2 | 427C | 8400 | 33E3 | CC1D | 1838 | B3E4 | B3E4 | 1838 |
| 4400 | 1F55 | E0AB | 4155 | 9F56 | 9F56 | 4155 | 8500 | 345C | CBA4 | 1746 | B45D | B45D | 1746 |
| 4500 | 1FE7 | E019 | 4030 | 9EF8 | 9FE8 | 4030 | 8600 | 34D5 | CB2B | 1655 | B4D6 | B4D6 | 1655 |
| 4600 | 2079 | DF87 | 3F0D | A07A | A07A | 3F0D | 8700 | 354D | CAB3 | 1565 | B54E | B54E | 1565 |
| 4700 | 2109 | DEF7 | 3DEC | A10A | A10A | 3DEC | 8800 | 35C5 | CA3B | 1475 | B5C6 | B5C6 | 1475 |
| 4800 | 2199 | DE67 | 3CCD | A19A | A19A | 3CCD | 8900 | 363C | C9C4 | 1386 | B63D | B63D | 1386 |
| 4900 | 2228 | DDD8 | 3BAF | A229 | A229 | 3BAF | 9000 | 36B3 | C94D | 1298 | B6B4 | B6B4 | 1298 |
| 5000 | 22B5 | DD4B | 3A94 | A2B6 | A2B6 | 3A94 | 9100 | 372B | C8D5 | 11A9 | B72C | B72C | 11A9 |
| 5100 | 2342 | DCBE | 397B | A343 | A343 | 397B | 9200 | 37A1 | C85F | 10BC | B7A2 | B7A2 | 10BC |
| 5200 | 23CE | DC32 | 3863 | A3CF | A3CF | 3863 | 9300 | 3818 | C7E8 | 0FCF | B819 | B819 | 0FCF |
| 5300 | 2459 | DBA7 | 374D | A45A | A45A | 374D | 9400 | 388E | C772 | 0EE2 | B88F | B88F | 0EE2 |
| 5400 | 24E3 | DB1D | 3639 | A4E4 | A4E4 | 3639 | 9500 | 3905 | C6FB | 0DF5 | B906 | B906 | 0DF5 |
| 5500 | 256C | DA94 | 3527 | A56D | A56D | 3527 | 9600 | 397B | C685 | 0D09 | B97C | B97C | 0D09 |
| 5600 | 25F4 | DA0C | 3416 | A5F5 | A5F5 | 3416 | 9700 | 39F0 | C610 | 0C1E | B9F1 | B9F1 | 0C1E |
| 5700 | 267C | D984 | 3306 | A67D | A67D | 3306 | 9800 | 3A66 | C59A | 0B32 | BA67 | BA67 | 0B32 |
| 5800 | 2703 | D8FD | 31F9 | A704 | A704 | 31F9 | 9900 | 3ADC | C524 | 0A47 | BADD | BADD | 0A47 |
| 5900 | 2789 | D877 | 30EC | A78A | A78A | 30EC | 10000 | 3B51 | C4AF | 095C | BB52 | BB52 | 095C |
| 6000 | 280E | D7F2 | 2FE2 | A80F | A80F | 2FE2 | 10100 | 3BC6 | C43A | 0872 | BBC7 | BBC7 | 0872 |
| 6100 | 2893 | D76D | 2ED8 | A894 | A894 | 2ED8 | 10200 | 3C3B | C3C5 | 0788 | BC3C | BC3C | 0788 |
| 6200 | 2917 | D6E9 | 2DD0 | A918 | A918 | 2DD0 | 10300 | 3CB1 | C34F | 069D | BCB2 | BCB2 | 069D |
| 6300 | 299A | D666 | 2CCA | A99B | A99B | 2CCA | 10400 | 3D26 | C2DA | 05B3 | BD27 | BD27 | 05B3 |
| 6400 | 2A1D | D5E3 | 2BC4 | AA1E | AA1E | 2BC4 | 10500 | 3D9A | C266 | 04CA | BD9B | BD9B | 04CA |
| 6500 | 2A9F | D561 | 2AC0 | AAA0 | AAA0 | 2AC0 | 10600 | 3E0F | C1F1 | 03E0 | BE10 | BE10 | 03E0 |
| 6600 | 2B21 | D4DF | 29BD | AB22 | AB22 | 29BD | 10700 | 3E84 | C17C | 02F6 | BE85 | BE85 | 02F6 |
| 6700 | 2BA1 | D45F | 28BC | ABA2 | ABA2 | 28BC | 10800 | 3EF9 | C107 | 020D | BEFA | BEFA | 020D |
| 6800 | 2C22 | D3DE | 27BB | AC23 | AC23 | 27BB | 10900 | 3F6E | C092 | 0123 | BF6F | BF6F | 0123 |
| 6900 | 2CA1 | D35F | 26BC | ACA2 | ACA2 | 26BC | 11000 | 3FE2 | C01E | 003A | BFE3 | BFE3 | 003A |
| 7000 | 2D21 | D2DF | 25BD | AD22 | AD22 | 25BD | OFF | 0000 | 8000 | 0000 | 0000 | 8000 | 0000 |

Table 14-5 (1). Coefficients of First-Stage IIR Filter (fs = 44.1kHz)

| Cut-off frequency (Hz) | Used as LPF | | | Used as HPF | | | Cut-off frequency (Hz) | Used as LPF | | | Used as HPF | | |
|---------------------------|-------------|--------|-------|-------------|--------|-------|---------------------------|-------------|--------|-------|-------------|--------|-------|
| | IIR*a1 | IIR*a0 | IIR*b | IIR*a1 | IIR*a0 | IIR*b | | IIR*a1 | IIR*a0 | IIR*b | IIR*a1 | IIR*a0 | IIR*b |
| 3000 | 153C | EAC4 | 5586 | 953D | 953D | 5586 | 7100 | 2ABD | D543 | 2A84 | AABE | AABE | 2A84 |
| 3100 | 15D6 | EA2A | 5452 | 95D7 | 95D7 | 5452 | 7200 | 2B34 | D4CC | 2996 | AB35 | AB35 | 2996 |
| 3200 | 1670 | E990 | 531F | 9671 | 9671 | 531F | 7300 | 2BAA | D456 | 28AA | ABAB | ABAB | 28AA |
| 3300 | 1707 | E8F9 | 51F0 | 9708 | 9708 | 51F0 | 7400 | 2C20 | D3E0 | 27BE | AC21 | AC21 | 27BE |
| 3400 | 179E | E862 | 50C3 | 979F | 979F | 50C3 | 7500 | 2C95 | D36B | 26D4 | AC96 | AC96 | 26D4 |
| 3500 | 1833 | E7CD | 4F98 | 9834 | 9834 | 4F98 | 7600 | 2D0A | D2F6 | 25EA | AD0B | AD0B | 25EA |
| 3600 | 18C7 | E739 | 4E70 | 98C8 | 98C8 | 4E70 | 7700 | 2D7F | D281 | 2501 | AD80 | AD80 | 2501 |
| 3700 | 195A | E6A6 | 4D4A | 995B | 995B | 4D4A | 7800 | 2DF3 | D20D | 2419 | ADF4 | ADF4 | 2419 |
| 3800 | 19EC | E614 | 4C26 | 99ED | 99ED | 4C26 | 7900 | 2E66 | D19A | 2332 | AE67 | AE67 | 2332 |
| 3900 | 1A7D | E583 | 4B05 | 9A7E | 9A7E | 4B05 | 8000 | 2ED9 | D127 | 224C | AEDA | AEDA | 224C |
| 4000 | 1B0C | E4F4 | 49E6 | 9B0D | 9B0D | 49E6 | 8100 | 2F4C | D0B4 | 2166 | AF4D | AF4D | 2166 |
| 4100 | 1B9B | E465 | 48C9 | 9B9C | 9B9C | 48C9 | 8200 | 2FBE | D042 | 2082 | AFBF | AFBF | 2082 |
| 4200 | 1C28 | E3D8 | 47AE | 9C29 | 9C29 | 47AE | 8300 | 3030 | CFD0 | 1F9E | B031 | B031 | 1F9E |
| 4300 | 1CB4 | E34C | 4696 | 9CB5 | 9CB5 | 4696 | 8400 | 30A2 | CF5E | 1EBA | B0A3 | B0A3 | 1EBA |
| 4400 | 1D40 | E2C0 | 457F | 9D41 | 9D41 | 457F | 8500 | 3113 | CEED | 1DD8 | B114 | B114 | 1DD8 |
| 4500 | 1DCA | E236 | 446A | 9DCB | 9DCB | 446A | 8600 | 3184 | CE7C | 1CF6 | B185 | B185 | 1CF6 |
| 4600 | 1E53 | E1AD | 4358 | 9E54 | 9E54 | 4358 | 8700 | 31F5 | CE0B | 1C15 | B1F6 | B1F6 | 1C15 |
| 4700 | 1EDC | E124 | 4247 | 9EDD | 9EDD | 4247 | 8800 | 3265 | CD9B | 1B35 | B266 | B266 | 1B35 |
| 4800 | 1F63 | E09D | 4138 | 9F64 | 9F64 | 4138 | 8900 | 32D5 | CD2B | 1A55 | B2D6 | B2D6 | 1A55 |
| 4900 | 1FEA | E016 | 402A | 9FEB | 9FEB | 402A | 9000 | 3345 | CCBB | 1975 | B346 | B346 | 1975 |
| 5000 | 2070 | DF90 | 3F1F | A071 | A071 | 3F1F | 9100 | 33B4 | CC4C | 1897 | B3B5 | B3B5 | 1897 |
| 5100 | 20F5 | DF0B | 3E15 | A0F6 | A0F6 | 3E15 | 9200 | 3423 | CBDD | 17B9 | B424 | B424 | 17B9 |
| 5200 | 2179 | DE87 | 3D0D | A17A | A17A | 3D0D | 9300 | 3492 | CB6E | 16DB | B493 | B493 | 16DB |
| 5300 | 21FC | DE04 | 3C07 | A1FD | A1FD | 3C07 | 9400 | 3500 | CB00 | 15FE | B501 | B501 | 15FE |
| 5400 | 227E | DD82 | 3B02 | A27F | A27F | 3B02 | 9500 | 356E | CA92 | 1522 | B56F | B56F | 1522 |
| 5500 | 2300 | DD00 | 39FE | A301 | A301 | 39FE | 9600 | 35DD | CA23 | 1445 | B5DE | B5DE | 1445 |
| 5600 | 2381 | DC7F | 38FD | A382 | A382 | 38FD | 9700 | 364A | C9B6 | 136A | B64B | B64B | 136A |
| 5700 | 2401 | DBFF | 37FD | A402 | A402 | 37FD | 9800 | 36B8 | C948 | 128F | B6B9 | B6B9 | 128F |
| 5800 | 2480 | DB80 | 36FE | A481 | A481 | 36FE | 9900 | 3725 | C8DB | 11B4 | B726 | B726 | 11B4 |
| 5900 | 24FF | DB01 | 3600 | A500 | A500 | 3600 | 10000 | 3793 | C86D | 10D9 | B794 | B794 | 10D9 |
| 6000 | 257D | DA83 | 3504 | A57E | A57E | 3504 | 10100 | 3800 | C800 | 0FFF | B801 | B801 | 0FFF |
| 6100 | 25FA | DA06 | 340A | A5FB | A5FB | 340A | 10200 | 386C | C794 | 0F26 | B86D | B86D | 0F26 |
| 6200 | 2677 | D989 | 3311 | A678 | A678 | 3311 | 10300 | 38D9 | C727 | 0E4D | B8DA | B8DA | 0E4D |
| 6300 | 26F3 | D90D | 3219 | A6F4 | A6F4 | 3219 | 10400 | 3945 | C6BB | 0D74 | B946 | B946 | 0D74 |
| 6400 | 276E | D892 | 3122 | A76F | A76F | 3122 | 10500 | 39B2 | C64E | 0C9B | B9B3 | B9B3 | 0C9B |
| 6500 | 27E9 | D817 | 302D | A7EA | A7EA | 302D | 10600 | 3A1E | C5E2 | 0BC2 | BA1F | BA1F | 0BC2 |
| 6600 | 2863 | D79D | 2F38 | A864 | A864 | 2F38 | 10700 | 3A8A | C576 | 0AEA | BA8B | BA8B | 0AEA |
| 6700 | 28DD | D723 | 2E45 | A8DE | A8DE | 2E45 | 10800 | 3AF6 | C50A | 0A12 | BAF7 | BAF7 | 0A12 |
| 6800 | 2956 | D6AA | 2D53 | A957 | A957 | 2D53 | 10900 | 3B62 | C49E | 093B | BB63 | BB63 | 093B |
| 6900 | 29CE | D632 | 2C62 | A9CF | A9CF | 2C62 | 11000 | 3BCE | C432 | 0863 | BBCF | BBCF | 0863 |
| 7000 | 2A46 | D5BA | 2B73 | AA47 | AA47 | 2B73 | OFF | 0000 | 8000 | 0000 | 0000 | 8000 | 0000 |

Table 14-5 (2). Coefficients of First-Stage IIR Filter ($f_s = 48\text{kHz}$)

| Cut-off frequency (Hz) | Used as LPF | | | Used as HPF | | | Cut-off frequency (Hz) | Used as LPF | | | Used as HPF | | |
|------------------------|-------------|--------|-------|-------------|--------|-------|------------------------|-------------|--------|-------|-------------|--------|-------|
| | IIR*a1 | IIR*a0 | IIR*b | IIR*a1 | IIR*a0 | IIR*b | | IIR*a1 | IIR*a0 | IIR*b | IIR*a1 | IIR*a0 | IIR*b |
| 3000 | 1DCA | E236 | 446A | 9DCB | 9DCB | 446A | 7100 | 3A54 | C5AC | 0B56 | BA55 | BA55 | 0B56 |
| 3100 | 1E98 | E168 | 42CF | 9E99 | 9E99 | 42CF | 7200 | 3AF6 | C50A | 0A12 | BAF7 | BAF7 | 0A12 |
| 3200 | 1F63 | E09D | 4138 | 9F64 | 9F64 | 4138 | 7300 | 3B98 | C468 | 08CF | BB99 | BB99 | 08CF |
| 3300 | 202D | DFD3 | 3FA4 | A02E | A02E | 3FA4 | 7400 | 3C39 | C3C7 | 078C | BC3A | BC3A | 078C |
| 3400 | 20F5 | DF0B | 3E15 | A0F6 | A0F6 | 3E15 | 7500 | 3CDB | C325 | 0649 | BCDC | BCDC | 0649 |
| 3500 | 21BA | DE46 | 3C8A | A1BB | A1BB | 3C8A | 7600 | 3D7C | C284 | 0507 | BD7D | BD7D | 0507 |
| 3600 | 227E | DD82 | 3B02 | A27F | A27F | 3B02 | 7700 | 3E1D | C1E3 | 03C5 | BE1E | BE1E | 03C5 |
| 3700 | 2341 | DCBF | 397D | A342 | A342 | 397D | 7800 | 3EBE | C142 | 0283 | BEBF | BEBF | 0283 |
| 3800 | 2401 | DBFF | 37FD | A402 | A402 | 37FD | 7900 | 3F5F | C0A1 | 0141 | BF60 | BF60 | 0141 |
| 3900 | 24C0 | DB40 | 367F | A4C1 | A4C1 | 367F | 8000 | 4000 | C000 | 0000 | C000 | C000 | 0000 |
| 4000 | 257D | DA83 | 3504 | A57E | A57E | 3504 | 8100 | 40A0 | BF60 | FEBF | C0A1 | C0A1 | FEBF |
| 4100 | 2639 | D9C7 | 338D | A63A | A63A | 338D | 8200 | 4141 | BEBF | FD7D | C142 | C142 | FD7D |
| 4200 | 26F3 | D90D | 3219 | A6F4 | A6F4 | 3219 | 8300 | 41E2 | BE1E | FC3B | C1E3 | C1E3 | FC3B |
| 4300 | 27AC | D854 | 30A7 | A7AD | A7AD | 30A7 | 8400 | 4283 | BD7D | FAF9 | C284 | C284 | FAF9 |
| 4400 | 2863 | D79D | 2F38 | A864 | A864 | 2F38 | 8500 | 4324 | BCDC | F9B7 | C325 | C325 | F9B7 |
| 4500 | 2919 | D6E7 | 2DCC | A91A | A91A | 2DCC | 8600 | 43C6 | BC3A | F874 | C3C7 | C3C7 | F874 |
| 4600 | 29CE | D632 | 2C62 | A9CF | A9CF | 2C62 | 8700 | 4467 | BB99 | F731 | C468 | C468 | F731 |
| 4700 | 2A82 | D57E | 2AFB | AA83 | AA83 | 2AFB | 8800 | 4509 | BAF7 | F5EE | C50A | C50A | F5EE |
| 4800 | 2B34 | D4CC | 2996 | AB35 | AB35 | 2996 | 8900 | 45AB | BA55 | F4AA | C5AC | C5AC | F4AA |
| 4900 | 2BE5 | D41B | 2834 | ABE6 | ABE6 | 2834 | 9000 | 464D | B9B3 | F365 | C64E | C64E | F365 |
| 5000 | 2C95 | D36B | 26D4 | AC96 | AC96 | 26D4 | 9100 | 46F0 | B910 | F220 | C6F1 | C6F1 | F220 |
| 5100 | 2D45 | D2BB | 2575 | AD46 | AD46 | 2575 | 9200 | 4793 | B86D | F0DA | C794 | C794 | F0DA |
| 5200 | 2DF3 | D20D | 2419 | ADF4 | ADF4 | 2419 | 9300 | 4836 | B7CA | EF94 | C837 | C837 | EF94 |
| 5300 | 2EA0 | D160 | 22BF | AEA1 | AEA1 | 22BF | 9400 | 48DA | B726 | EE4C | C8DB | C8DB | EE4C |
| 5400 | 2F4C | D0B4 | 2166 | AF4D | AF4D | 2166 | 9500 | 497E | B682 | ED04 | C97F | C97F | ED04 |
| 5500 | 2FF8 | D008 | 200F | AFF9 | AFF9 | 200F | 9600 | 4A22 | B5DE | EBBB | CA23 | CA23 | EBBB |
| 5600 | 30A2 | CF5E | 1EBA | B0A3 | B0A3 | 1EBA | 9700 | 4AC8 | B538 | EA70 | CAC9 | CAC9 | EA70 |
| 5700 | 314C | CEB4 | 1D67 | B14D | B14D | 1D67 | 9800 | 4B6D | B493 | E925 | CB6E | CB6E | E925 |
| 5800 | 31F5 | CE0B | 1C15 | B1F6 | B1F6 | 1C15 | 9900 | 4C14 | B3EC | E7D8 | CC15 | CC15 | E7D8 |
| 5900 | 329D | CD63 | 1AC5 | B29E | B29E | 1AC5 | 10000 | 4CBA | B346 | E68B | CCBB | CCBB | E68B |
| 6000 | 3345 | CCBB | 1975 | B346 | B346 | 1975 | 10100 | 4D62 | B29E | E53B | CD63 | CD63 | E53B |
| 6100 | 33EB | CC15 | 1828 | B3EC | B3EC | 1828 | 10200 | 4E0A | B1F6 | E3EB | CE0B | CE0B | E3EB |
| 6200 | 3492 | CB6E | 16DB | B493 | B493 | 16DB | 10300 | 4EB3 | B14D | E299 | CEB4 | CEB4 | E299 |
| 6300 | 3537 | CAC9 | 1590 | B538 | B538 | 1590 | 10400 | 4F5D | B0A3 | E146 | CF5E | CF5E | E146 |
| 6400 | 35DD | CA23 | 1445 | B5DE | B5DE | 1445 | 10500 | 5007 | AFF9 | DFF1 | D008 | D008 | DFF1 |
| 6500 | 3681 | C97F | 12FC | B682 | B682 | 12FC | 10600 | 50B3 | AF4D | DE9A | D0B4 | D0B4 | DE9A |
| 6600 | 3725 | C8DB | 11B4 | B726 | B726 | 11B4 | 10700 | 515F | AEA1 | DD41 | D160 | D160 | DD41 |
| 6700 | 37C9 | C837 | 106C | B7CA | B7CA | 106C | 10800 | 520C | ADF4 | DBE7 | D20D | D20D | DBE7 |
| 6800 | 386C | C794 | 0F26 | B86D | B86D | 0F26 | 10900 | 52BA | AD46 | DA8B | D2BB | D2BB | DA8B |
| 6900 | 390F | C6F1 | 0DE0 | B910 | B910 | 0DE0 | 11000 | 536A | AC96 | D92C | D36B | D36B | D92C |
| 7000 | 39B2 | C64E | 0C9B | B9B3 | B9B3 | 1C9B | OFF | 0000 | 8000 | 0000 | 0000 | 8000 | 0000 |

Table 14-5 (3). Coefficients of First-Stage IIR Filter (fs = 32kHz)

Filter Characteristics

ADC Filter Characteristics (75th + 15th FIR)

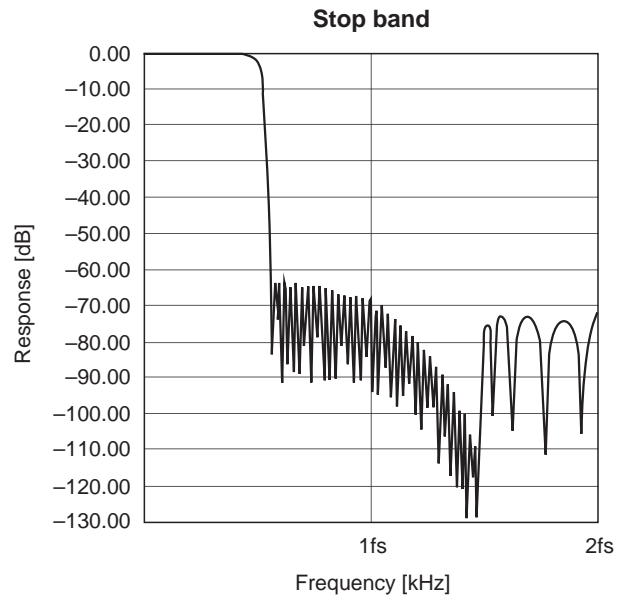
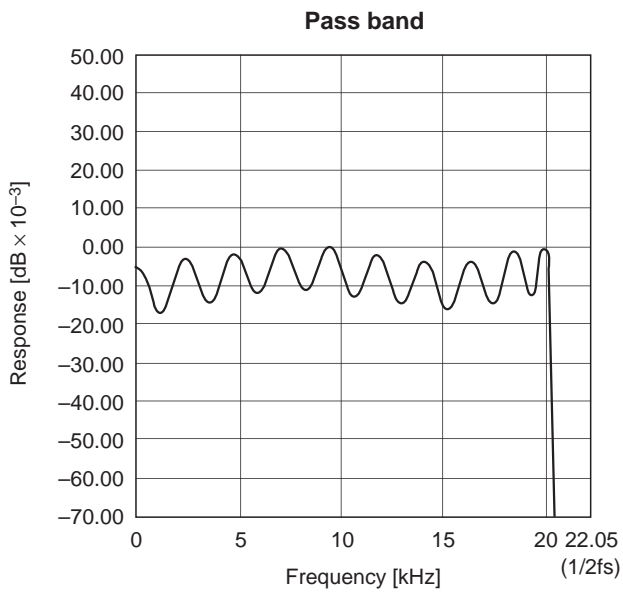

DAC Filter Characteristics (43rd + 7th FIR)

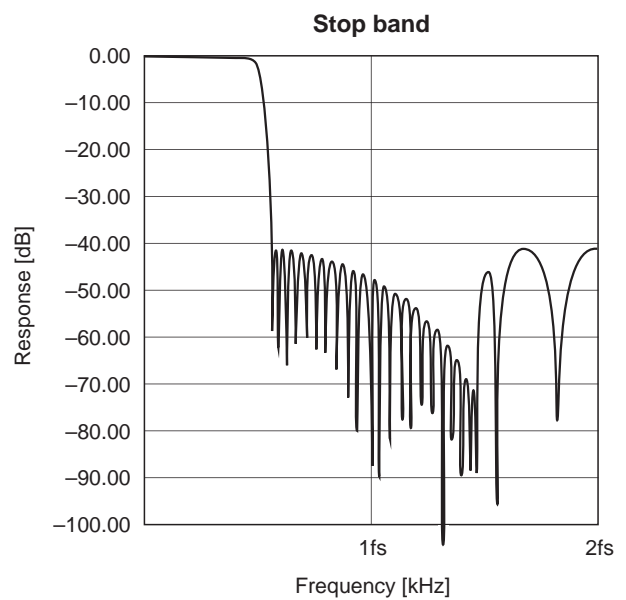
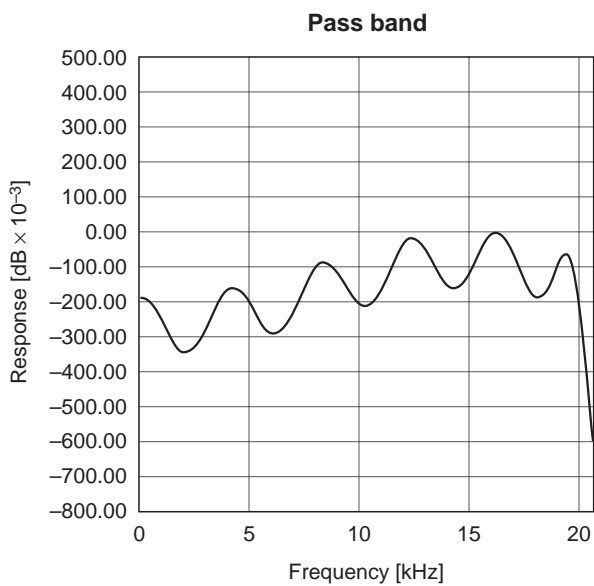

Application Circuit

- 1 : AD operational amplifier +12V power supply
 - 2 : DA operational amplifier +12V power supply
 - 3 : AD operational amplifier -12V power supply
 - 4 : DA operational amplifier -12V power supply
 - A : Crystal oscillator circuit +5V power supply
 - B : AIN1 +5V power supply
 - C : AIN2 +5V power supply
 - D : AIN3 +5V power supply
 - E : AO1 +5V power supply
 - F : AO2 +5V power supply
 - ↑ : Digital power supply +5V
- 5532 operational amplifier used

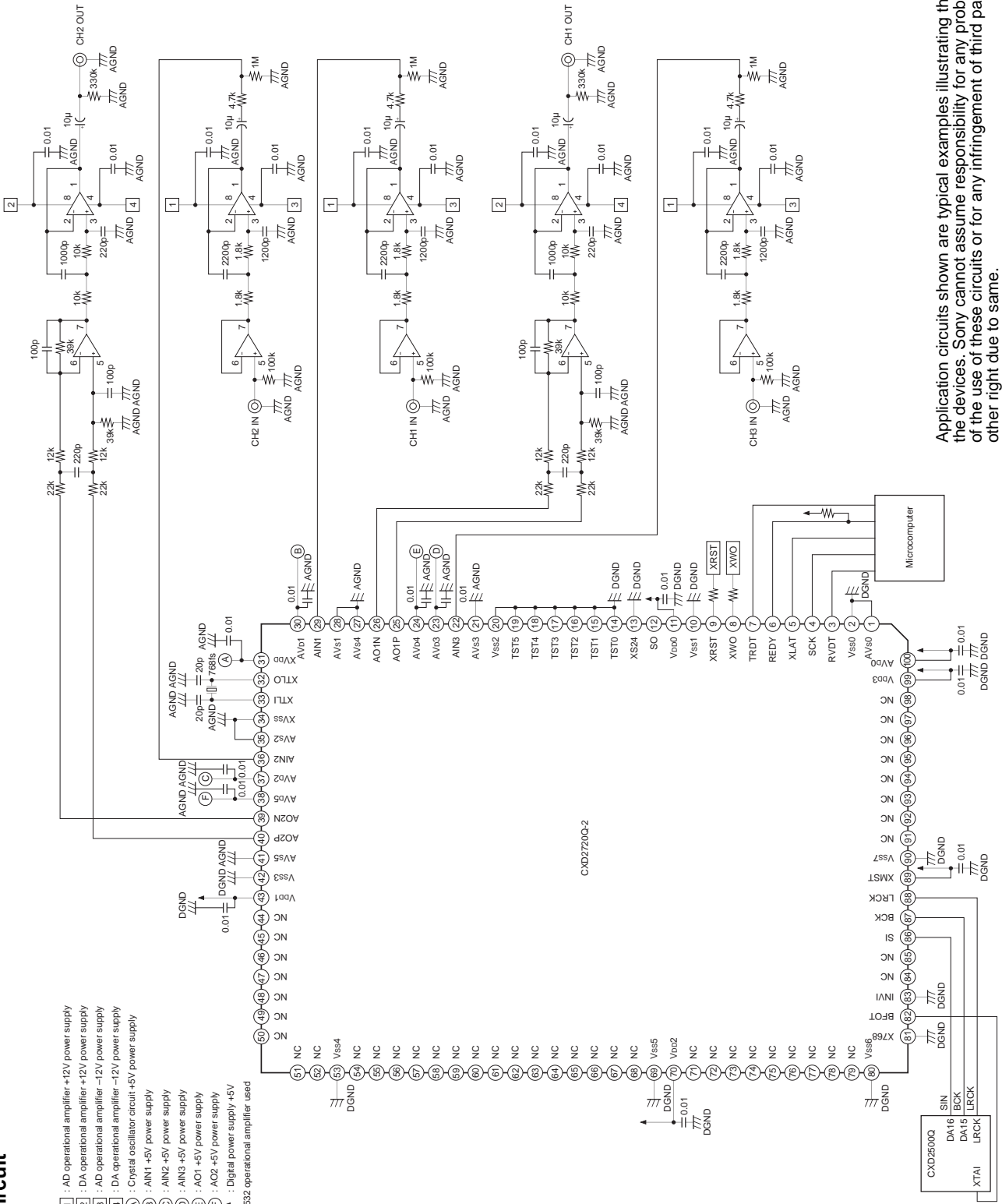

Application circuits shown are typical examples illustrating the operation of the devices. Sony cannot assume responsibility for any problems arising out of the use of these circuits or for any infringement of third party patent and other right due to same.

Package Outline

Unit: mm

100PIN QFP (PLASTIC)

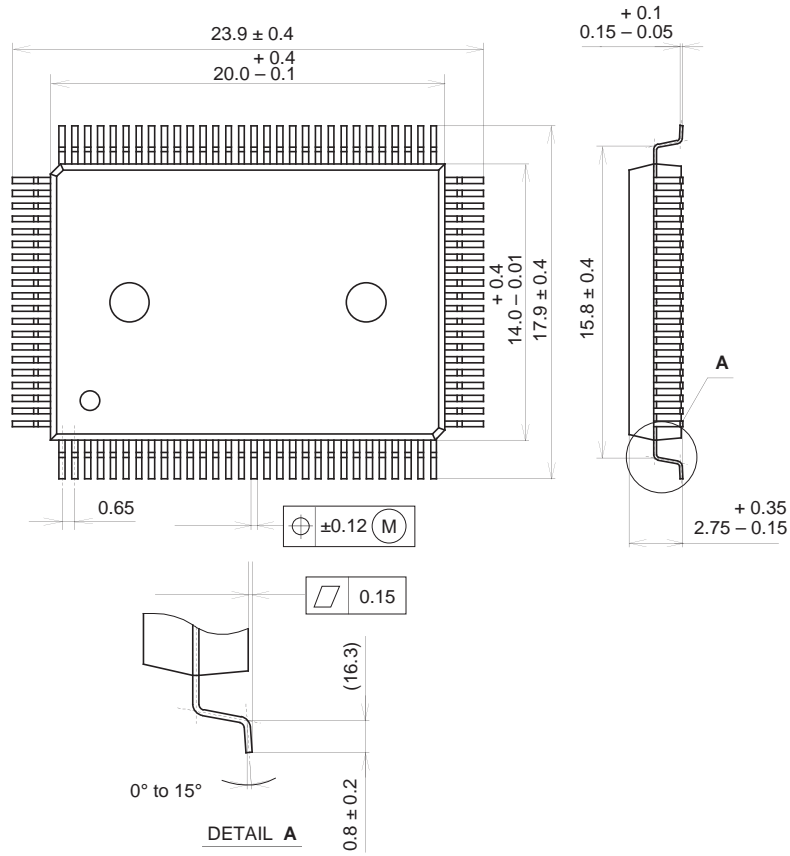

PACKAGE STRUCTURE

| | |
|------------|------------------|
| SONY CODE | QFP-100P-L01 |
| EIAJ CODE | *QFP100-P-1420-A |
| JEDEC CODE | _____ |

| | |
|------------------|-------------------|
| PACKAGE MATERIAL | EPOXY RESIN |
| LEAD TREATMENT | SOLDER PLATING |
| LEAD MATERIAL | COPPER / 42 ALLOY |
| PACKAGE WEIGHT | 1.4g |