

ACT-SF2816 High Speed 128Kx16 SRAM / 512Kx16 FLASH Multichip Module



FEATURES

- 2 – 128K x 8 SRAMs & 2 – 512K x 8 Flash Die in One MCM
- Access Times of 25ns (SRAM) and 60ns (Flash) or 35ns (SRAM) and 70 or 90ns (Flash)
- Organized as 128K x 16 of SRAM and 512K x 16 of Flash Memory with Separate Data Buses
- Both Blocks of Memory are User Configurable as 512KX8 AND 1MX8 Respectively
- Low Power CMOS
- Input and Output TTL Compatible Design
- MIL-PRF-38534 Compliant MCMs Available
- Decoupling Capacitors and Multiple Grounds for Low Noise
- Industrial and Military Temperature Ranges
- Industry Standard Pinouts
- Packaging – Hermetic Ceramic
 - 66 Pin, 1.08" x 1.08" x .160" PGA Type, No Shoulder, Aeroflex code# "P3"
 - 66 Pin, 1.08" x 1.08" x .185" PGA Type, With Shoulder, Aeroflex code# "P7"
 - 68 Lead, .94" x .94" x .140" Single-Cavity Small Outline Gull Wing, Aeroflex code# "F18" (Drops into the 68 Lead JEDEC .99"SQ CQFJ footprint)
- DESC SMD – TBD

FLASH MEMORY FEATURES

- Sector Architecture (Each Die)
 - 8 Equal Sectors of 64K bytes each
 - Any combination of sectors can be erased with one command sequence
- +5V Programming, +5V Supply
- Embedded Erase and Program Algorithms
- Hardware and Software Write Protection
- Internal Program Control Time.
- 10,000 Erase / Program Cycles

Note: Programming information available upon request

Block Diagram – PGA Type Packages (P3 & P7) & CQFP (F18)

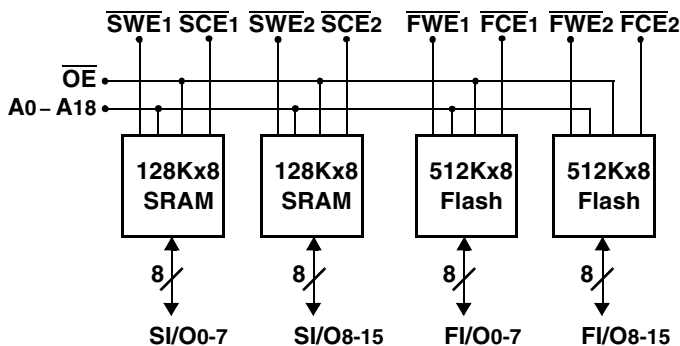

Pin Description

FI/O0-15	Flash Data I/O
SI/O0-15	SRAM Data I/O
A0-18	Address Inputs
FWE1-2	Flash Write Enables
SWE1-2	SRAM Write Enables
FCE1-2	Flash Chip Enables
SCE1-2	SRAM Chip Enables
OE	Output Enable
NC	Not Connected
Vcc	Power Supply
GND	Ground

Absolute Maximum Ratings

Symbol	Rating	Range	Units
T _C	Operating Temperature	-55 to +125	°C
T _{STG}	Storage Temperature	-65 to +150	°C
V _G	Maximum Signal Voltage to Ground	-0.5 to +7	V
T _L	Maximum Lead Temperature (10 seconds)	300	°C

Parameter	
Flash Data Retention	10 Years
Flash Endurance (Write/Erase Cycles)	10,000

Normal Operating Conditions

Symbol	Parameter	Minimum	Maximum	Units
V _{CC}	Power Supply Voltage	+4.5	+5.5	V
V _{IH}	Input High Voltage	+2.2	V _{CC} + 0.3	V
V _{IL}	Input Low Voltage	-0.5	+0.8	V

Capacitance

(V_{IN} = 0V, f = 1MHz, T_C = 25°C)

Symbol	Parameter	Maximum	Units
C _{AD}	A ₀ – A ₁₈ Capacitance	50	pF
C _{OE}	\overline{OE} Capacitance	50	pF
C _{WE1,2}	F/S Write Enable Capacitance	20	pF
C _{CCE1,2}	F/S Chip Enable Capacitance	20	pF
C _{I/O}	I/O ₀ – I/O ₁₅ Capacitance	20	pF

These parameters are guaranteed by design but not tested

DC Characteristics

(V_{CC} = 5.0V, V_{SS} = 0V, T_C = -55°C to +125°C, unless otherwise indicated)

Parameter	Sym	Conditions	Min	Max	Units
Input Leakage Current	I _{LI}	V _{CC} = Max, V _{IN} = 0 to V _{CC}		10	μA
Output Leakage Current	I _{LO}	$\overline{FCE} = \overline{SCE} = V_{IH}$, $\overline{OE} = V_{IH}$, V _{OUT} = 0 to V _{CC}		10	μA
SRAM Operating Supply Current x 16 Mode	I _{CCx16}	$\overline{SCE} = V_{IL}$, $\overline{OE} = V_{IH}$, f = 5MHz, V _{CC} = Max, $\overline{FCE} = V_{IH}$		325	mA
Standby Current	I _{SB}	$\overline{FCE} = \overline{SCE} = V_{IH}$, $\overline{OE} = V_{IH}$, f = 5MHz, V _{CC} = Max		40	mA
SRAM Output Low Voltage	V _{OL}	I _{OL} = 8 mA, V _{CC} = Min, $\overline{FCE} = V_{IH}$		0.4	V
SRAM Output High Voltage	V _{OH}	I _{OH} = -4.0 mA, V _{CC} = Min, $\overline{FCE} = V_{IH}$	2.4		V
Flash Vcc Active Current for Read (1)	I _{CC1}	$\overline{FCE} = V_{IL}$, $\overline{OE} = V_{IH}$, $\overline{SCE} = V_{IH}$		130	mA
Flash Vcc Active Current for Program or Erase (2)	I _{CC2}	$\overline{FCE} = V_{IL}$, $\overline{OE} = V_{IH}$, $\overline{SCE} = V_{IH}$		150	mA
Flash Output Low Voltage	V _{OL}	I _{OL} = 8 mA, V _{CC} = Min, $\overline{SCE} = V_{IH}$		0.45	V
Flash Output High Voltage	V _{OH}	I _{OH} = -2.5 mA, V _{CC} = Min, $\overline{SCE} = V_{IH}$	0.85 x V _{CC}		V
Flash Low Vcc Lock Out Voltage	V _{LKO}		3.2		V

Notes: 1) The I_{CC} current listed includes both the DC operating current and the frequency dependent component (at 5MHz). The frequency component typically is less than 2mA/MHz, with \overline{OE} at V_{IH} 2) I_{CC} active while Embedded Algorithm (program or erase) is in progress 3) DC test conditions: V_{IL} = 0.3V, V_{IH} = V_{CC} - 0.3V

SRAM AC Characteristics

(V_{CC} = 5.0V, V_{SS} = 0V, T_c = -55°C to +125°C)

Read Cycle

Parameter	Symbol	-025		-035		Units
		Min	Max	Min	Max	
Read Cycle Time	t _{RC}	25		35		ns
Address Access Time	t _{AA}		25		35	ns
Chip Select Access Time	t _{ACE}		25		35	ns
Output Hold from Address Change	t _{OH}	0		0		ns
Output Enable to Output Valid	t _{OE}		15		20	ns
Chip Select to Output in Low Z *	t _{CLZ}	3		3		ns
Output Enable to Output in Low Z *	t _{OLZ}	0		0		ns
Chip Deselect to Output in High Z *	t _{CHZ}		12		20	ns
Output Disable to Output in High Z *	t _{OHZ}		12		20	ns

* Parameters guaranteed by design but not tested

Write Cycle

Parameter	Symbol	-025		-035		Units
		Min	Max	Min	Max	
Write Cycle Time	t _{WC}	25		35		ns
Chip Select to End of Write	t _{CW}	20		25		ns
Address Valid to End of Write	t _{AW}	20		25		ns
Data Valid to End of Write	t _{DW}	15		20		ns
Write Pulse Width	t _{WP}	20		25		ns
Address Setup Time	t _{AS}	0		0		ns
Output Active from End of Write *	t _{OW}	0		0		ns
Write to Output in High Z *	t _{WHZ}		10		20	ns
Data Hold from Write Time	t _{DH}	0		0		ns
Address Hold Time	t _{AH}	0		0		ns

* Parameters guaranteed by design but not tested

Truth Table

Mode	\overline{SCE}	\overline{OE}	\overline{SWE}	Data I/O	Power
Standby	H	X	X	High Z	Standby
Read	L	L	H	Data Out	Active
Output Disable	L	H	H	High Z	Active
Write	L	X	L	Data In	Active

Timing Diagrams — SRAM

Read Cycle Timing Diagrams

Read Cycle 1 ($\overline{SCE} = \overline{OE} = V_{IL}$, $\overline{SWE} = V_{IH}$)

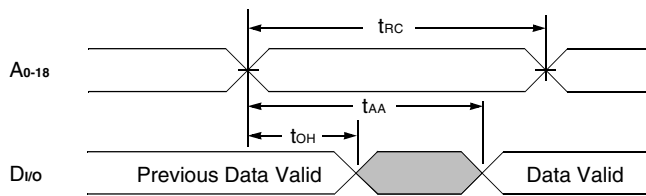

Read Cycle 2 ($\overline{SWE} = V_{IH}$)

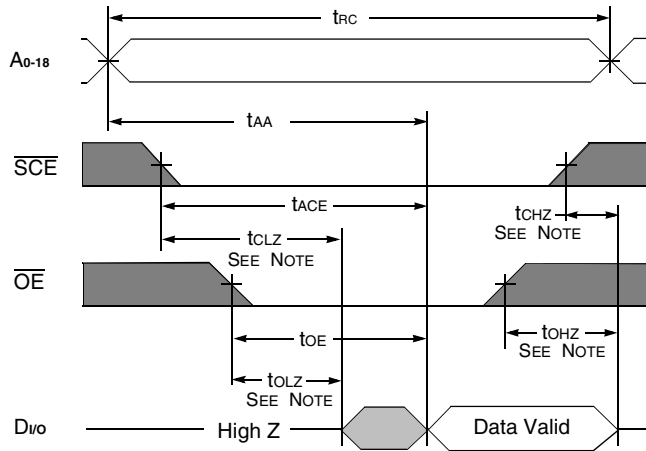

Write Cycle Timing Diagrams

Write Cycle (\overline{SWE} Controlled, $\overline{OE} = V_{IH}$)

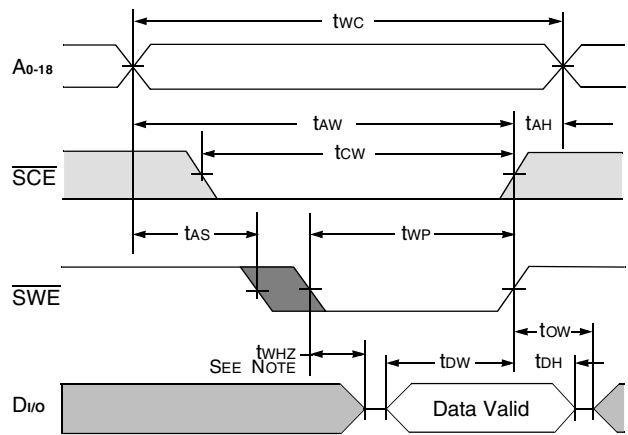

Write Cycle (\overline{SCE} Controlled, $\overline{OE} = V_{IH}$)

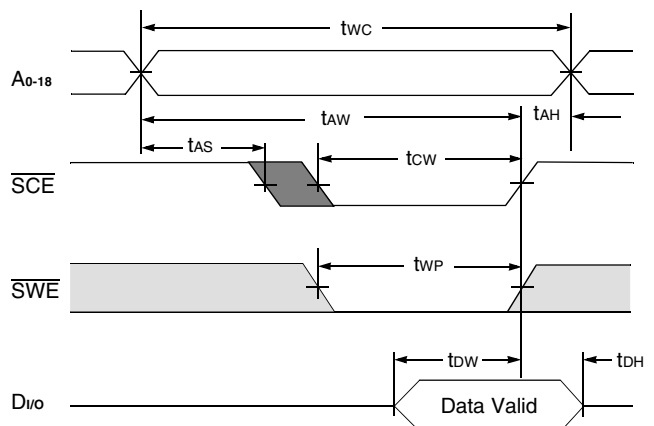

Note: Guaranteed by design, but not tested.

AC Test Circuit

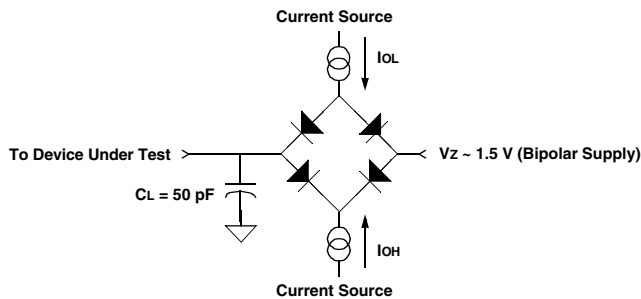

AC Test Conditions

Parameter	Typical	Units
Input Pulse Level	0 – 3.0	V
Input Rise and Fall	5	ns
Input and Output Timing Reference Level	1.5	V

Notes:

- 1) Vz is programmable from -2V to +7V.
- 2) IOL and IOH programmable from 0 to 16 mA.
- 3) Tester Impedance ZO = 75Ω.
- 4) Vz is typically the midpoint of VOH and VOL.
- 5) IOL and IOH are adjusted to simulate a typical resistance load circuit.
- 6) ATE Tester includes jig capacitance.

Flash AC Characteristics – Read Only Operations

(V_{cc} = 5.0V, V_{ss} = 0V, T_c = -55°C to +125°C)

Parameter	Symbol		-60		-70		-90		Units
	JEDEC	Stand'd	Min	Max	Min	Max	Min	Max	
Read Cycle Time	t _{AVAV}	t _{rc}	60		70		90		ns
Address Access Time	t _{AVQV}	t _{acc}		60		70		90	ns
Chip Enable Access Time	t _{ELQV}	t _{ce}		60		70		90	ns
Output Enable to Output Valid	t _{GLQV}	t _{oe}		30		35		35	ns
Chip Enable to Output High Z (1)	t _{EHQZ}	t _{df}		20		20		20	ns
Output Enable High to Output High Z(1)	t _{GHQZ}	t _{df}		20		20		20	ns
Output Hold from Address, \overline{CE} or \overline{OE} Change, Whichever is First	t _{AXQX}	t _{oh}	0		0		0		ns

Note 1. Guaranteed by design, but not tested

Flash AC Characteristics – Write / Erase / Program Operations, \overline{FWE} Controlled

(V_{cc} = 5.0V, V_{ss} = 0V, T_c = -55°C to +125°C)

Parameter	Symbol		-60		-70		-90		Units
	JEDEC	Stand'd	Min	Max	Min	Max	Min	Max	
Write Cycle Time	t _{AVAC}	t _{wc}	60		70		90		ns
Chip Enable Setup Time	t _{ELWL}	t _{ce}	0		0		0		ns
Write Enable Pulse Width	t _{WLWH}	t _{wp}	40		45		45		ns
Address Setup Time	t _{AVWL}	t _{as}	0		0		0		ns
Data Setup Time	t _{DVWH}	t _{ds}	40		45		45		ns
Data Hold Time	t _{WHDX}	t _{dh}	0		0		0		ns
Address Hold Time	t _{WLAX}	t _{ah}	45		45		45		ns
Write Enable Pulse Width High	t _{WHWL}	t _{wph}	20		20		20		ns
Duration of Byte Programming Operation	t _{WHWH1}		14	TYP	14	TYP	14	TYP	μs
Sector Erase Time	t _{WHWH2}			30		30		30	Sec
Read Recovery Time before Write	t _{GHWL}		0		0		0		μs
V _{cc} Setup Time		t _{vce}		50		50		50	μs
Chip Programming Time				50		50		50	Sec
Chip Enable Hold Time		t _{oeh} ¹		10		10		10	ns
Chip Erase Time	t _{WHWH3}			120		120		120	Sec

1. Toggle and Data Polling only.

Flash AC Characteristics – Write / Erase / Program Operations, \overline{FCE} Controlled

(V_{cc} = 5.0V, V_{ss} = 0V, T_c = -55°C to +125°C)

Parameter	Symbol		-60		-70		-90		Units
	JEDEC	Stand'd	Min	Max	Min	Max	Min	Max	
Write Cycle Time	t _{AVAC}	t _{wc}	60		70		90		ns
Write Enable Setup Time	t _{WLEL}	t _{ws}	0		0		0		ns
Chip Enable Pulse Width	t _{LELH}	t _{cp}	40		45		45		ns
Address Setup Time	t _{AVEL}	t _{as}	0		0		0		ns
Data Setup Time	t _{DVEH}	t _{ds}	40		45		45		ns
Data Hold Time	t _{EHDX}	t _{dh}	0		0		0		ns
Address Hold Time	t _{ELAX}	t _{ah}	45		45		45		ns
Chip Enable Pulse Width High	t _{EHEL}	t _{cpH}	20		20		20		ns
Duration of Byte Programming	t _{WHWH1}		14	TYP	14	TYP	14	TYP	μs
Sector Erase Time	t _{WHWH2}			30		30		30	Sec
Read Recovery Time	t _{GHEL}		0		0		0		ns
Chip Programming Time				50		50		50	Sec
Chip Erase Time	t _{WHWH3}			120		120		120	Sec

AC Waveforms for Flash Memory Read Operations

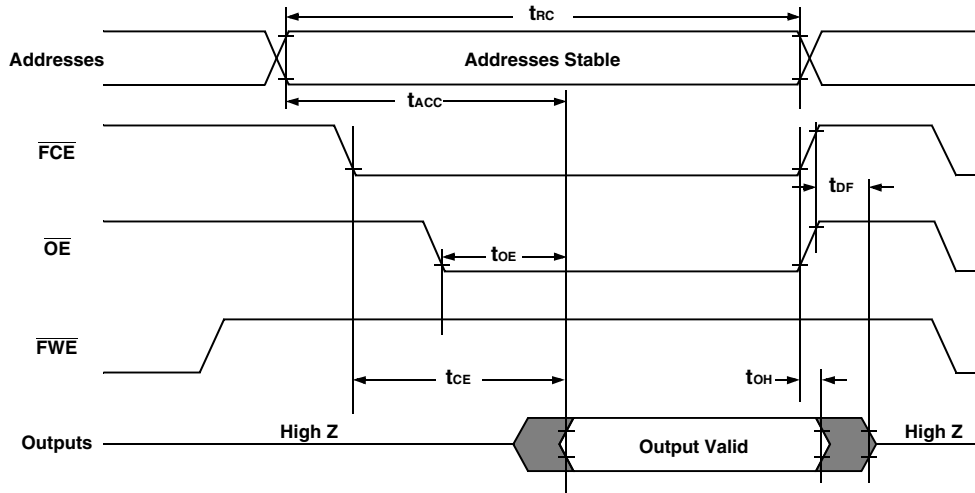

Write/Erase/Program Operation for Flash Memory, \overline{FWE} Controlled

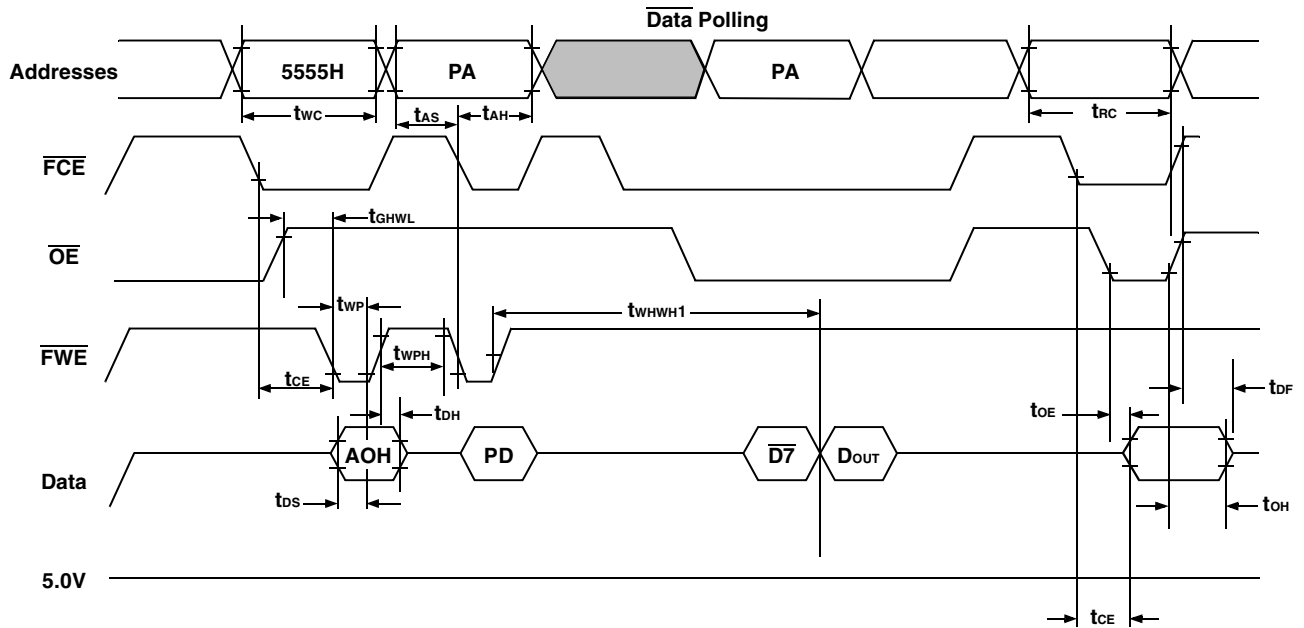

Notes:

1. PA is the address of the memory location to be programmed.
2. PD is the data to be programmed at byte address.
3. D7 is the Output of the complement of the data written to the device.
4. DOUT is the output of the data written to the device.
5. Figure indicates last two bus cycles of four bus cycle sequence.

AC Waveforms Chip/Sector Erase Operations for Flash Memory

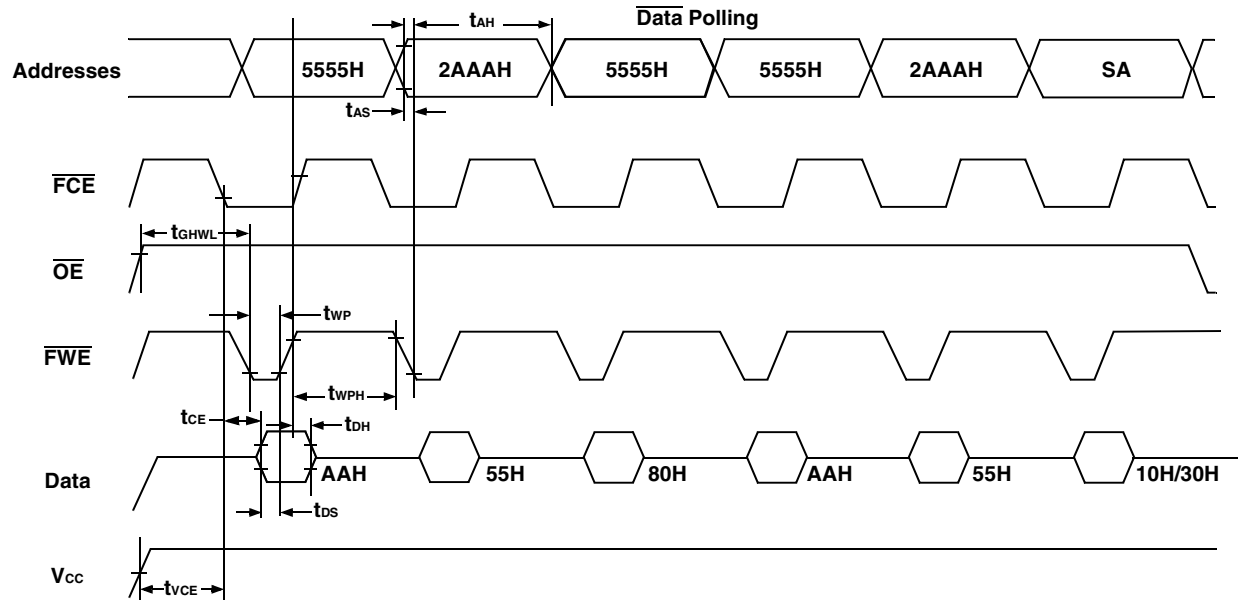

- Notes:**
 1. SA is the sector address for sector erase.

AC Waveforms for Data Polling During Embedded Algorithm Operations for Flash Memory

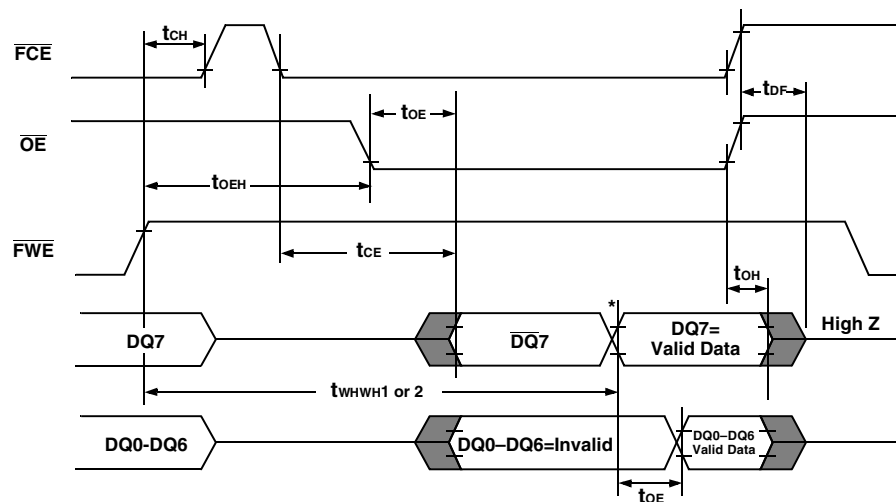

* DQ7=Valid Data (The device has completed the Embedded operation).

Write/Erase/Program Operation for Flash Memory, $\overline{\text{FCE}}$ Controlled

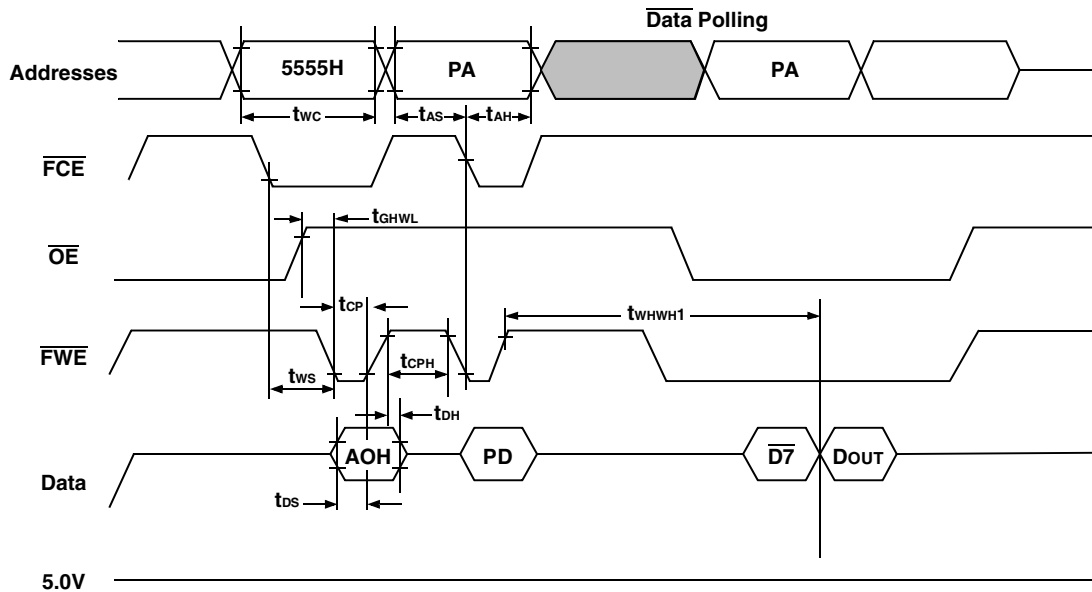

Notes:

1. PA is the address of the memory location to be programmed.
2. PD is the data to be programmed at byte address.
3. $\overline{\text{D7}}$ is the Output of the complement of the data written to the device.
4. DOUT is the output of the data written to the device.
5. Figure indicates last two bus cycles of four bus cycle sequence.

Pin Numbers & Functions

66 Pins — PGA-Type							
Pin #	Function	Pin #	Function	Pin #	Function	Pin #	Function
1	SI/O ₈	18	A ₁₂	35	FI/O ₉	52	$\overline{\text{FWE}}_1$
2	SI/O ₉	19	V _{CC}	36	FI/O ₁₀	53	$\overline{\text{FCE}}_1$
3	SI/O ₁₀	20	$\overline{\text{SCE}}_1$	37	A ₆	54	GND
4	A ₁₃	21	NC	38	A ₇	55	FI/O ₃
5	A ₁₄	22	SI/O ₃	39	NC	56	FI/O ₁₅
6	A ₁₅	23	SI/O ₁₅	40	A ₈	57	FI/O ₁₄
7	A ₁₆	24	SI/O ₁₄	41	A ₉	58	FI/O ₁₃
8	A ₁₇	25	SI/O ₁₃	42	FI/O ₀	59	FI/O ₁₂
9	SI/O ₀	26	SI/O ₁₂	43	FI/O ₁	60	A ₀
10	SI/O ₁	27	$\overline{\text{OE}}$	44	FI/O ₂	61	A ₁
11	SI/O ₂	28	A ₁₈	45	V _{CC}	62	A ₂
12	$\overline{\text{SWE}}_2$	29	$\overline{\text{SWE}}_1$	46	$\overline{\text{FCE}}_2$	63	FI/O ₇
13	$\overline{\text{SCE}}_2$	30	SI/O ₇	47	$\overline{\text{FWE}}_2$	64	FI/O ₆
14	GND	31	SI/O ₆	48	FI/O ₁₁	65	FI/O ₅
15	SI/O ₁₁	32	SI/O ₅	49	A ₃	66	FI/O ₄
16	A ₁₀	33	SI/O ₄	50	A ₄		
17	A ₁₁	34	FI/O ₈	51	A ₅		

"P3" — 1.08" SQ PGA Type Package Standard (without shoulders)

"P7" — 1.08" SQ PGA Type Package (with shoulders on Pins 1, 11, 56 & 66)

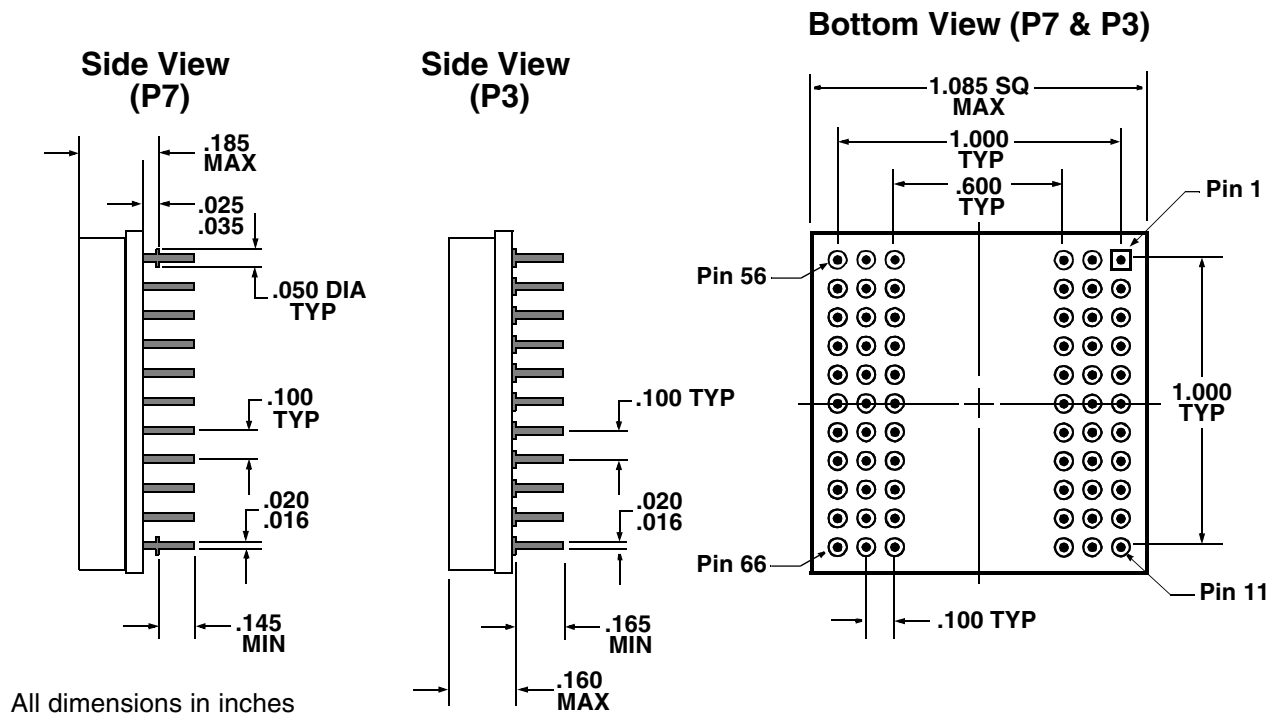

Pin Numbers & Functions

68 Pins — Dual-Cavity CQFP

Pin #	Function	Pin #	Function	Pin #	Function	Pin #	Function
1	GND	18	GND	35	\overline{OE}	52	GND
2	$\overline{FCE1}$	19	SI/O ₈	36	$\overline{SCE2}$	53	FI/O ₇
3	A ₅	20	SI/O ₉	37	A ₁₇	54	FI/O ₆
4	A ₄	21	SI/O ₁₀	38	$\overline{SWE2}$	55	FI/O ₅
5	A ₃	22	SI/O ₁₁	39	$\overline{FWE1}$	56	FI/O ₄
6	A ₂	23	SI/O ₁₂	40	$\overline{FWE2}$	57	FI/O ₃
7	A ₁	24	SI/O ₁₃	41	A ₁₈	58	FI/O ₂
8	A ₀	25	SI/O ₁₄	42	NC	59	FI/O ₁
9	NC	26	SI/O ₁₅	43	NC	60	FI/O ₀
10	SI/O ₀	27	V _{CC}	44	FI/O ₁₅	61	V _{CC}
11	SI/O ₁	28	A ₁₁	45	FI/O ₁₄	62	A ₁₀
12	SI/O ₂	29	A ₁₂	46	FI/O ₁₃	63	A ₉
13	SI/O ₃	30	A ₁₃	47	FI/O ₁₂	64	A ₈
14	SI/O ₄	31	A ₁₄	48	FI/O ₁₁	65	A ₇
15	SI/O ₅	32	A ₁₅	49	FI/O ₁₀	66	A ₆
16	SI/O ₆	33	A ₁₆	50	FI/O ₉	67	$\overline{SWE1}$
17	SI/O ₇	34	$\overline{SCE1}$	51	FI/O ₈	68	$\overline{FCE2}$

"F18" — CQFP Package

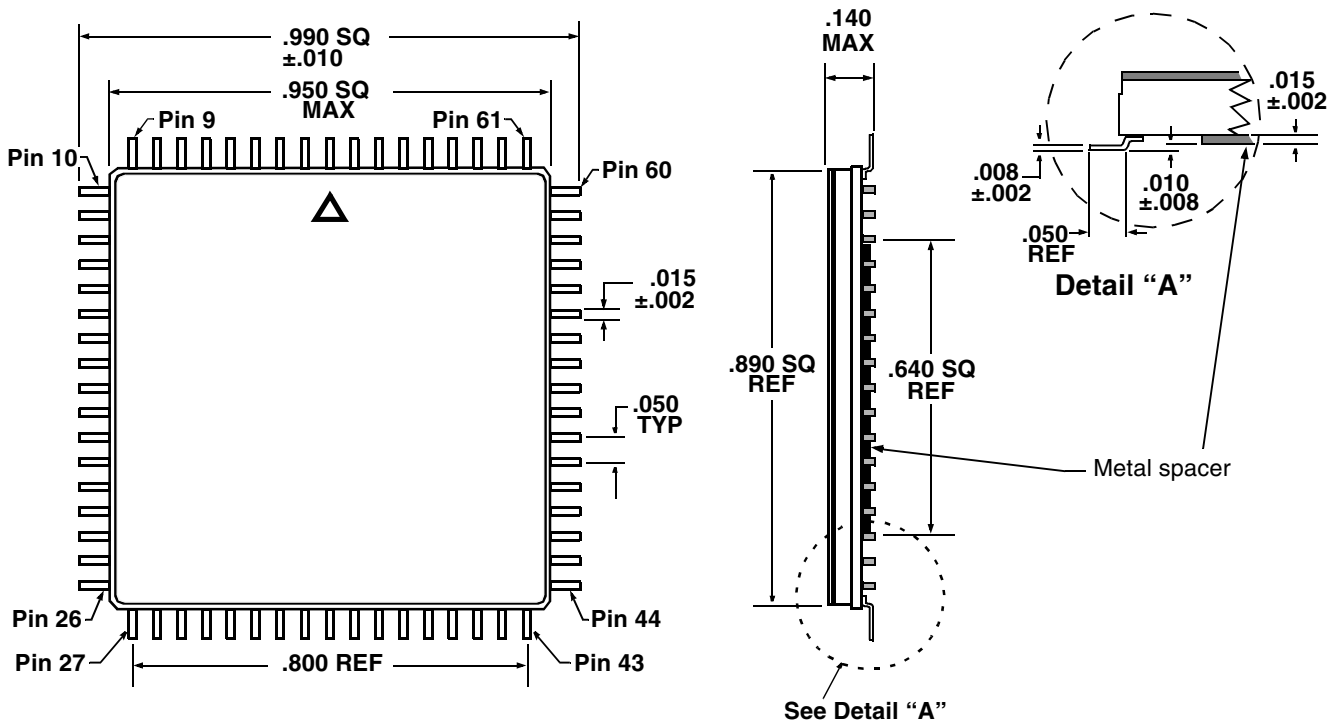

All dimensions in inches



Ordering Information

Model Number	DESC SMD Number	Speed	Package
ACT-SF2816N-26P3Q	TBD	25(S) / 60(F) ns	1.08"sq PGA-Type
ACT-SF2816N-37P3Q	TBD	35(S) / 70(F) ns	1.08"sq PGA-Type
ACT-SF2816N-39P3Q	TBD	35(S) / 90(F) ns	1.08"sq PGA-Type
ACT-SF2816N-26P7Q	TBD	25(S) / 60(F) ns	1.08"sq PGA-Type
ACT-SF2816N-37P7Q	TBD	35(S) / 70(F) ns	1.08"sq PGA-Type
ACT-SF2816N-39P7Q	TBD	35(S) / 90(F) ns	1.08"sq PGA-Type
ACT-SF2816N-26F18Q	TBD	25(S) / 60(F) ns	.94"sq CQFP
ACT-SF2816N-37F18Q	TBD	35(S) / 70(F) ns	.94"sq CQFP
ACT-SF2816N-39F18Q	TBD	35(S) / 90(F) ns	.94"sq CQFP

Note: (S) = Speed for SRAM, (F) = Speed for FLASH

Part Number Breakdown

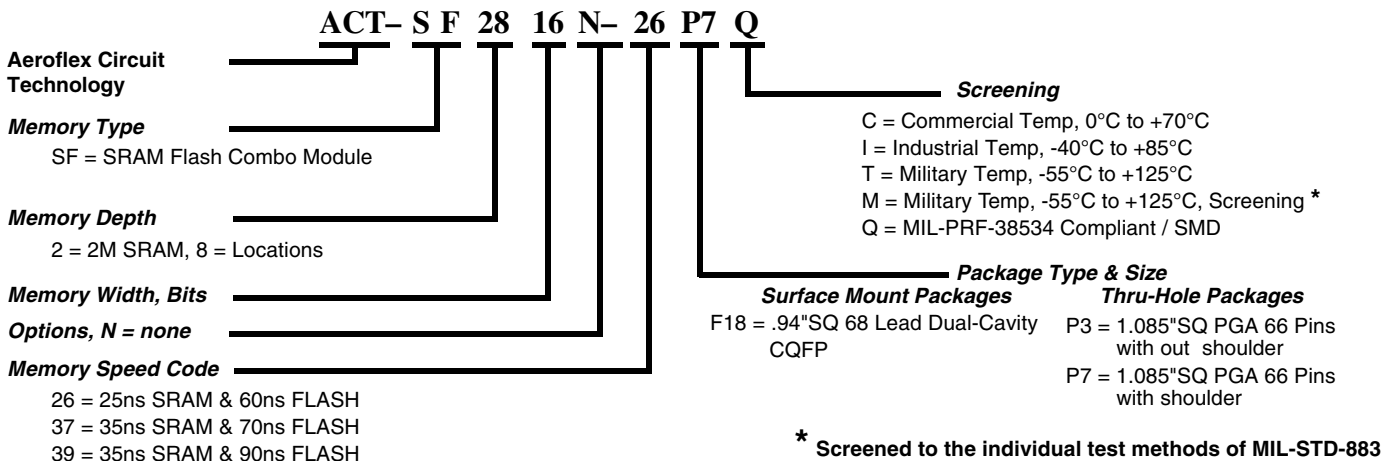

Specifications subject to change without notice.

Aeroflex Circuit Technology 35 South Service Road Plainview New York 11830	Telephone: (516) 694-6700 FAX: (516) 694-6715 Toll Free Inquiries: 1-(800) 843-1553
---	--