

MOC8030
MOC8050

DESCRIPTION

The MOC8030 and MOC8050 are photodarlington-type optically coupled optocouplers. The devices have a gallium arsenide infrared emitting diode coupled with a silicon darlington phototransistor.

FEATURES

- High BV_{CEO}
-Minimum 80 V
- High current transfer ratio
-300% (MOC8030)
-500% (MOC8050)
- No base connection for improved noise immunity
- Underwriters Laboratory (UL) recognized File# E90700

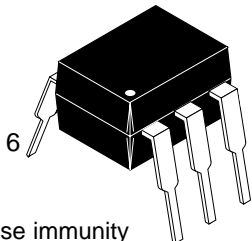

APPLICATIONS

- Appliances, measuring instruments
- I/O interface for computers
- Programmable controllers
- Portable electronics
- Interfacing and coupling systems of different potentials and impedance
- Solid state relays

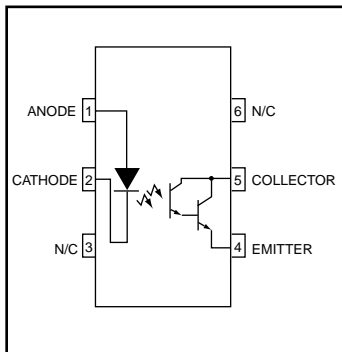

PACKAGE DIMENSIONS

NOTE
All dimensions are in inches (millimeters)

ABSOLUTE MAXIMUM RATINGS ($T_A = 25^\circ\text{C}$ Unless otherwise specified.)			
Parameter	Symbol	Value	Units
TOTAL DEVICE			
Storage Temperature	T_{STG}	-55 to +150	$^\circ\text{C}$
Operating Temperature	T_{OPR}	-55 to +100	$^\circ\text{C}$
Lead Solder Temperature	T_{SOL}	260 for 10 sec	$^\circ\text{C}$
Total Device Power Dissipation @ $T_A = 25^\circ\text{C}$	P_D	250	mW
Derate above 25°C		2.94	mW/ $^\circ\text{C}$
Input-Output Isolation Voltage	V_{ISO}	5300	Vac(rms)
EMITTER			
DC/Average Forward Input Current	I_F	60	mA
Reverse Input Voltage	V_R	3	V
LED Power Dissipation @ $T_A = 25^\circ\text{C}$	P_D	120	mW
Derate above 25°C		1.41	mW/ $^\circ\text{C}$
DETECTOR			
Collector-Emitter Voltage	V_{CEO}	80	V
Detector Power Dissipation @ $T_A = 25^\circ\text{C}$	P_D	150	mW
Derate above 25°C		1.76	mW/ $^\circ\text{C}$
Continuous Collector Current	I_C	150	mA



PHOTODARLINGTON OPTOCOUPERS

Preliminary (NO BASE CONNECTION)

MOC8030
MOC8050

ELECTRICAL CHARACTERISTICS ($T_A = 25^\circ\text{C}$ Unless otherwise specified.)

INDIVIDUAL COMPONENT CHARACTERISTICS

Parameter	Test Conditions	Symbol	Min	Typ**	Max	Unit
EMITTER						
Input Forward Voltage	($I_F = 10\text{ mA}$)	V_F		1.15	2	V
Input Capacitance	($V_F = 0, f = 1\text{ MHz}$)	C_{IN}		18		pF
Reverse Leakage Current	($V_R = 3.0\text{ V}$)	I_R		0.05	10	μA
DETECTOR						
Collector-Emitter Breakdown Voltage	($I_C = 1.0\text{ mA}$)	BV_{CEO}	80			V
Emitter-Collector Breakdown Voltage	($I_E = 100\text{ }\mu\text{A}$)	BV_{ECO}	5			V
Collector-Emitter Dark Current	($V_{CE} = 60\text{ V}$)	I_{CEO}			1	μA

TRANSFER CHARACTERISTICS

DC Characteristic	Test Conditions	Symbol	Min	Typ**	Max	Units
Current Transfer Ratio, Collector-Emitter	MOC8030 ($I_F = 10\text{ mA}, V_{CE} = 1.5\text{ V}$)	CTR	300			%
	MOC8050 ($I_F = 10\text{ mA}, V_{CE} = 1.5\text{ V}$)		500			

TRANSFER CHARACTERISTICS

Characteristic	Test Conditions	Symbol	Min	Typ**	Max	Units
SWITCHING TIMES						
Turn-on Time	($V_{CC} = 10\text{ V}, R_L = 100\Omega, I_F = 5\text{ mA}$)	t_{on}		3.5		μs
Turn-off Time		t_{off}		95		μs

ISOLATION CHARACTERISTICS

Characteristic	Test Conditions	Symbol	Min	Typ**	Max	Units
Input-Output Isolation Voltage	($I_{I-O} \leq 1\text{ }\mu\text{A}, 1\text{ min.}$)	V_{ISO}	7500			Vac(pk)
	($I_{I-O} \leq 1\text{ }\mu\text{A}, 1\text{ min.}$)		5300			Vac(rms)
Isolation Resistance	($V_{I-O} = 500\text{ VDC}$)	R_{ISO}	10^{11}			Ω
Isolation Capacitance	($f = 1\text{ MHz}$)	C_{ISO}		0.5		pf

Note

** Typical values at $T_A = 25^\circ\text{C}$

MOC8030
MOC8050

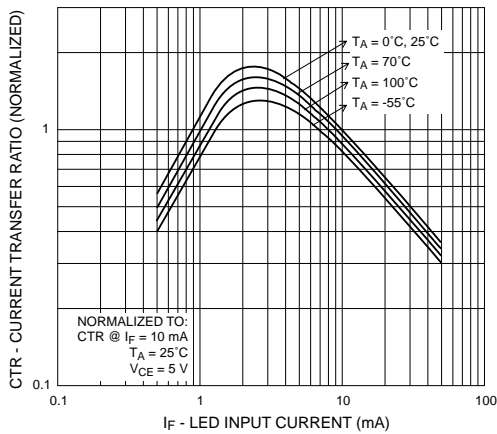

Fig. 1 Output Current vs. Input Current

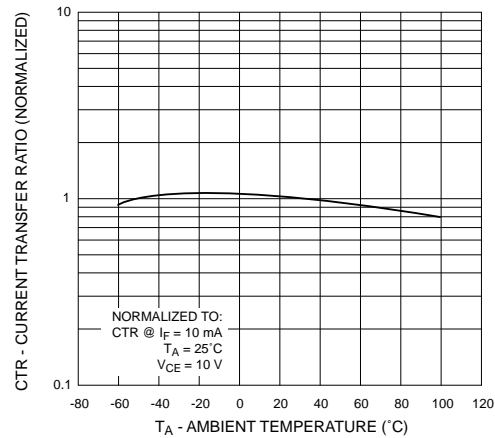

Fig. 2 Current Transfer Ratio vs. Ambient Temperature

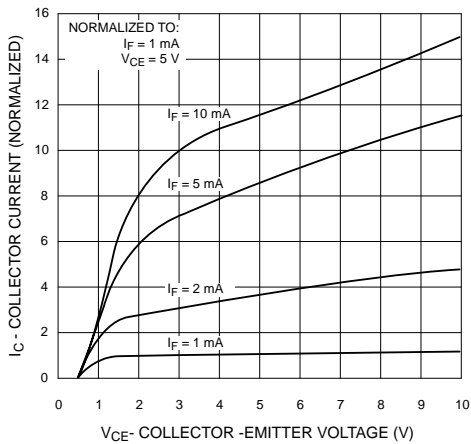

Fig. 3 Collector Current vs. Collector-Emitter Voltage

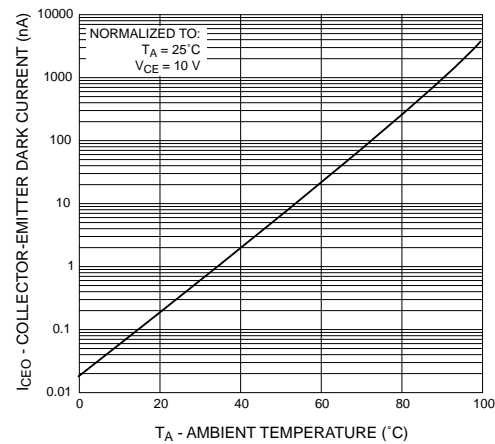

Fig. 4 Dark Current vs. Ambient Temperature

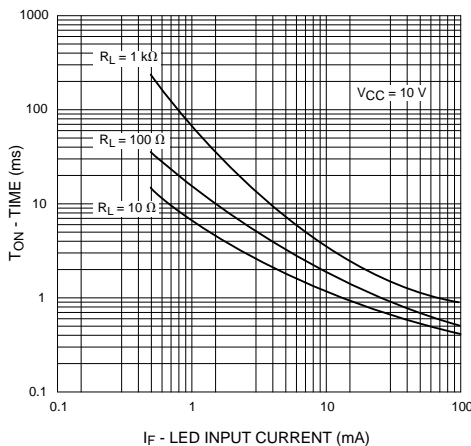

Fig. 5 Turn-On Time vs. Input Current

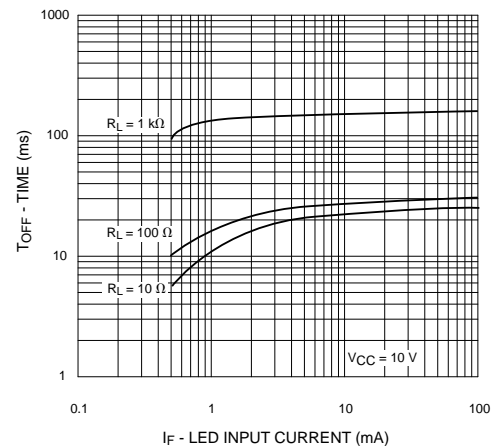
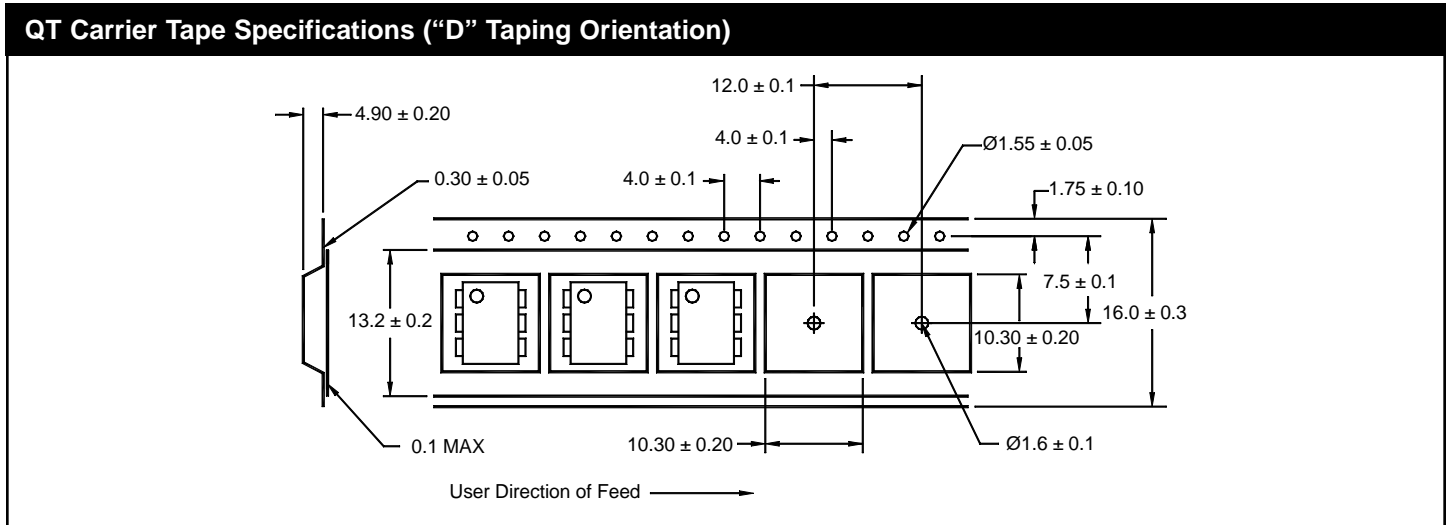

Fig. 6 Turn-Off Time vs. Input Current

MOC8030
MOC8050

ORDERING INFORMATION

Option	Order Entry Identifier	Description
S	.S	Surface Mount Lead Bend
SD	.SD	Surface Mount; Tape and reel
W	.W	0.4" Lead Spacing
300	.300	VDE 0884
300W	.300W	VDE 0884, 0.4" Lead Spacing
3S	.3S	VDE 0884, Surface Mount
3SD	.3SD	VDE 0884, Surface Mount, Tape & Reel



Corporate Headquarters

QT Optoelectronics
610 North Mary Avenue
Sunnyvale, CA 94086
(408) 720-1440 Phone
(408) 720-0848 Fax

North American Sales

QT Optoelectronics
16775 Addison Rd., Suite 200
Addison, TX 75001
(972) 447-1300 Phone
(972) 447-0784 Fax

European Sales

Quality Technologies Deutschland GmbH
Max-Huber-Strasse 8
D-85737 Ismaning, Germany
49 [0] 89/96.30.51 Phone
49 [0] 89/96.54.74 Fax

European Sales

QT Optoelectronics
"Le Levant"
2, rue du Nouveau Bercy
F-94277-CHARENTON-LE PONT Cedex
FRANCE
33 [0] 1.45.18.78.78 Phone
33 [0] 1.43.75.77.57 Fax

Asia/Pacific Sales

QT Optoelectronics
B613, 6th Floor
East Wing, Wisma Tractors
Jalan SS16/1, Subang Jaya
47500 Petaling Jaya
Selangor Darul Eshan, Malaysia
603/735-2417 Phone
603/736-3382 Fax

European Sales

Quality Technologies (U.K) Ltd.
10, Prebendal Court, Oxford Road
Aylesbury, Buckinghamshire
HP19-3EY United Kingdom
44 [0] 1296/30.44.99 Phone
44 [0] 1296/39.24.32 Fax

www.qtopto.com

Call QT Optoelectronics for more information or the phone number of your nearest distributor.

United States 800-533-6786 • France 33 [0] 1.45.18.78.78 • Germany 49 [0] 89/96.30.51 • United Kingdom 44 [0] 1296 394499 • Asia/Pacific 603-7352417