

Voltage Mode PWM Control Circuit with 200mA Output Drivers

Description

The CS3524A PWM control circuit retains the same versatile architecture of the industry standard CS3524 (SG3524) while adding substantial improvements.

The CS3524 is pin-compatible with "non-A" versions, and in most applications can be directly interchanged. The CS3524A, however, eliminates many of the design restrictions which had previously required additional external circuitry.

The CS3524A includes a precision 5V reference trimmed to $\pm 1\%$ accuracy (eliminating the need for potentiometer adjustments), an error amplifier with an output voltage swing extending to 5V, and a current sense amplifier useful in either the ground or power supply output lines. The uncommitted 60V, 200mA NPN output pair greatly enhances the output drive capability.

The CS3524A features an undervoltage lockout circuit which disables all internal circuitry (except the reference) until the input voltage has risen to 8V. This holds standby current low until turn-on, and greatly simplifies the design of low power, off-line supplies. The turn-on circuit has approximately 600mV of hysteresis for jitter free activation.

Other improvements include a PWM latch that insures freedom from multiple pulsing within a period, even in noisy environments; logic to eliminate double pulsing on a single output, a 200ns external shutdown capability, and automatic thermal protection from excessive chip temperature. The oscillator circuit is usable to 500kHz and is easier to synchronize with an external clock pulse.

Features

- Precision Reference Internally Trimmed to $\pm 1\%$
- Current Limit
- Undervoltage Lockout
- Start-up Supply Current < 4mA
- Output to 200mA
- 60V Output Capability
- Wide Common-mode Input Range for Error and Current Limit Amplifiers
- PWM Latch Insures Single Pulse per Period
- Double Pulse Suppression
- 200ns Shutdown
- Guaranteed Frequency
- Thermal Shutdown

Block Diagram

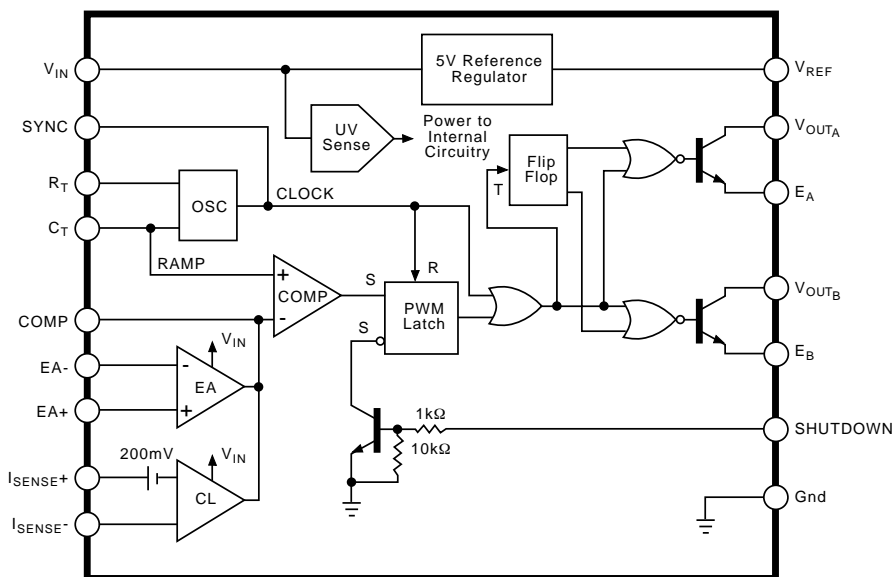

Package Options

16 Lead PDIP & SO Wide

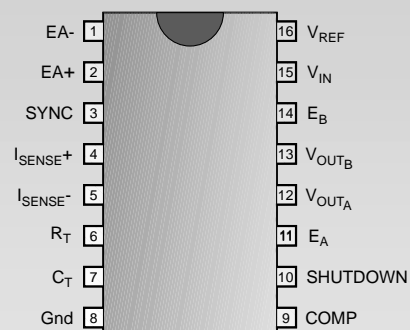

Absolute Maximum Ratings

Supply Voltage (V_{IN}).....	40V
Collector Supply Voltage (V_{CC}).....	60V
Output Current (Each Output).....	200mA
Reference Output Current.....	50mA
Oscillator Charging Current	5mA
Power Dissipation at $T_A=25^\circ\text{C}$	1000mW
Power Dissipation at $T_J=+25^\circ\text{C}$	2000mW
Derate for Case Temperature above $+25^\circ\text{C}$	16mW/ $^\circ\text{C}$
Storage Temperature Range	-65°C to $+150^\circ\text{C}$
Lead Temperature Soldering: Wave Solder (through hole styles only).....	10 sec. max, 260°C peak
Reflow (SMD styles only).....	60 sec. max above 183°C , 230°C peak

Electrical Characteristics: $0^\circ\text{C} \leq T_A \leq +70^\circ\text{C}$ for the CS3524A; $V_{IN} = V_{CC} = 20\text{V}$; unless otherwise stated.

PARAMETER	TEST CONDITIONS	MIN	TYP	MAX	UNIT
■ Turn-on Characteristics					
Input Voltage	Operating range after Turn-on	8		40	V
Turn-on Threshold		5.5	7.5	8.5	V
Turn-on Current	V_{IN} Turn-on - 100mV		2.5	4.0	mA
Operating Current	$V_{IN} = 8$ to 40V		5	10	mA
Turn-on Hysteresis*			0.6		V
■ Reference Section					
Output Voltage	$T_A = 25^\circ\text{C}$	4.90	5.00	5.20	V
Line Regulation	$V_{IN} = 10$ to 40V		10	30	mV
Load Regulation	$I_L = 0$ to 20mA		20	50	mA
Temperature Stability*	Over Operating Range		20	50	mV
Short Circuit Current	$V_{REF} = 0$, $T_A = 25^\circ\text{C}$		80	100	mA
Output Noise Voltage*	$10\text{Hz} \leq f \leq 10\text{kHz}$, $T_A = 25^\circ\text{C}$		40		μVrms
Long Term Stability*	$T_A = 125^\circ\text{C}$; 1000 Hrs.		20	50	mV
■ Oscillator Section (Unless otherwise specified, $R_T = 2700\Omega$, $C_T = 0.01\mu\text{F}$)					
Initial Accuracy	$T_A = 25^\circ\text{C}$	39	43	47	kHz
Temperature Stability*	Over Operating Temperature Range		1	2	%
Minimum Frequency	$R_T = 150\text{k}\Omega$, $C_T = 0.1\mu\text{F}$			120	Hz
Maximum Frequency	$R_T = 2.0\text{k}\Omega$, $C_T = 470\text{pF}$	500			kHz
Output Amplitude*	$T_A = 25^\circ\text{C}$		3.5		V
Output Pulse Width*	$T_A = 25^\circ\text{C}$		0.5		μs
Ramp Peak		3.3	3.5	3.7	V
Ramp Valley		0.7	0.9	1.0	V
■ Error Amplifier Section (Unless otherwise specified, $V_{CM} = 2.5\text{V}$)					
Input Offset Voltage			2	10	mV
Input Bias Current			1	10	μA
Input Offset Current			0.5	1.0	μA
Common Mode Rejection Ratio	$V_{CM} = 1.5$ to 5.5V	60	75		dB
Power Supply Rejection Ratio	$V_{IN} = 10$ to 40V	50	60		dB
Output Swing	Minimum Total Range	0.5		5.0	V

* These parameters are guaranteed by design but not 100% tested in production.

Electrical Characteristics: continued

PARAMETER	TEST CONDITIONS	MIN	TYP	MAX	UNIT
■ Error Amplifier Section (Unless otherwise specified, $V_{CM} = 2.5V$): continued					
Open Loop Voltage Gain	$\Delta V_{OUT} = 1$ to $4V$, $R_L \geq 10 M\Omega$	60	80		dB
Gain-Bandwidth*	$T_A = 25^\circ C$, $A_V = 0dB$		3		MHz

■ Current Limit Amplifier (Unless otherwise specified, $V_{SENSE} = V_O$)

Input Offset Voltage	$T_A = 25^\circ C$, EA Set for Max. Output	180	200	220	mV
Input Offset Voltage	Over Operating Temperature Range	170		230	mV
Input Bias Current			-1	-10	μA
Common Mode Rejection Ratio	$V_{SENSE} = 0$ to $15V$	50	60		dB
Power Supply Rejection Ratio	$V_{IN} = 10$ to $40V$	50	60		dB
Output Swing	Minimum Total Range	0.5		5.0	V
Open Loop Voltage Gain	$\Delta V_{OUT} = 1$ to $4V$, $R_L \geq 10M\Omega$	70	80		dB
Delay Time*	$\Delta V_{IN} = 300mV$		300		ns

■ Output Section (Each Output)

Collector Emitter Voltage	$I_C = 100\mu A$	60	80		V
Collector Leakage Current	$V_{CE} = 50V$		0.1	20.0	μA
Saturation	$I_C = 20mA$		0.2	0.4	V
	$I_C = 200mA$		1.0	2.2	V
Emitter Output Voltage	$I_E = 50mA$	17	18		V
Rise Time*	$T_A = 25^\circ C$, $R = 2k\Omega$		200		ns
Fall Time*	$T_A = 25^\circ C$, $R = 2k\Omega$		100		ns
Comparator Delay*	$T_A = 25^\circ C$, V_{COMP} to V_{OUT}		300		ns
Shutdown Delay*	$T_A = 25^\circ C$, V_{SHUT} to V_{OUT}		200		ns
Shutdown Threshold	$T_A = 25^\circ C$, $R_C = 2k\Omega$	0.5	0.7	1.0	V
Thermal Shutdown*			165		$^\circ C$

* These parameters are guaranteed by design but not 100% tested in production.

Typical Performance Characteristics

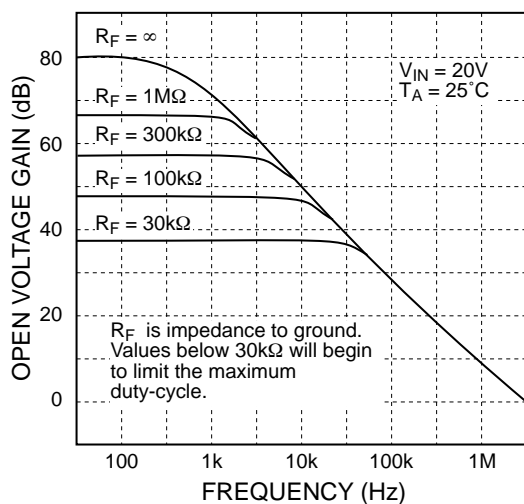
Error Amplifier Voltage Gain vs. Frequency Over R_F 

Duty Cycle vs. Input Voltage

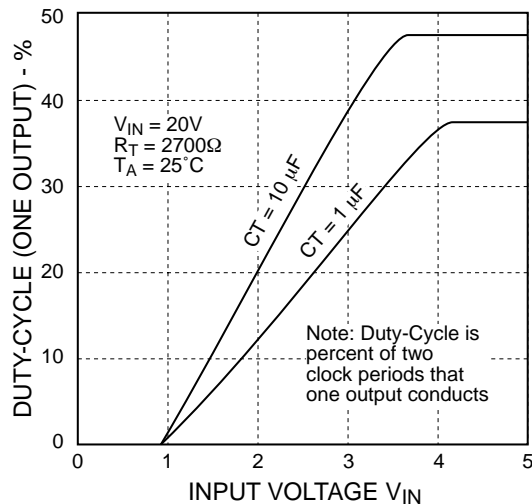

Typical Performance Characteristics continued

Quiescent Supply Current vs. Supply Voltage Over Temperature

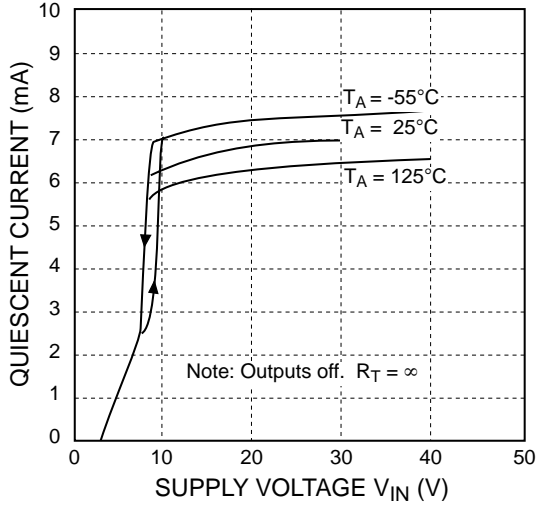

Shutdown Delay From PWM Comparator

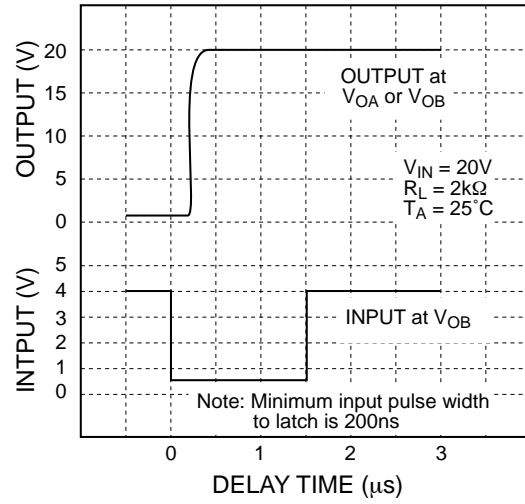

Oscillator Frequency vs. Timing Components Resistor Over Timing Capacitance

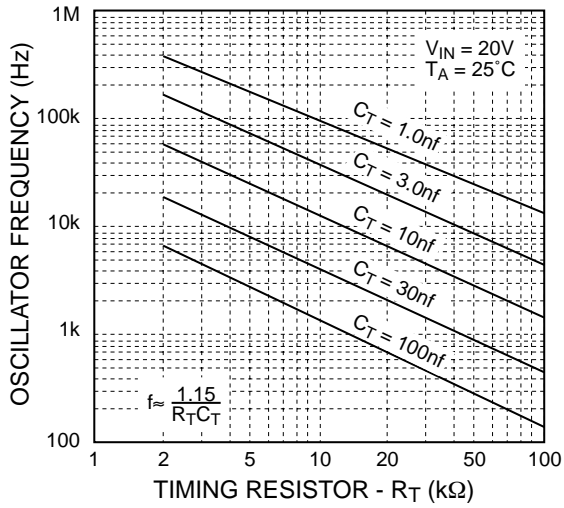

Output Dead Time vs. Timing Capacitor Value

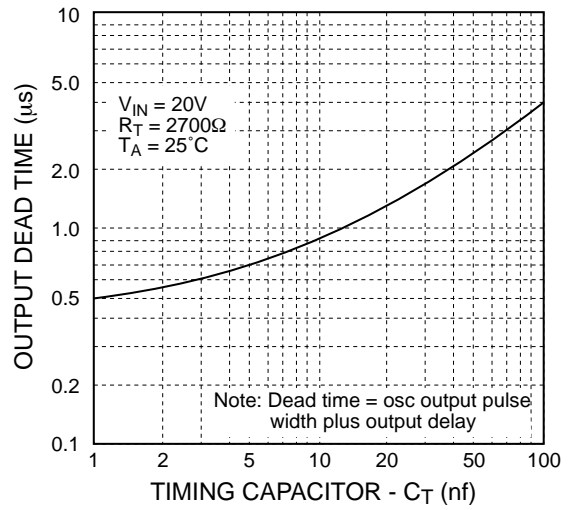

Current Limit Amplifier Delay

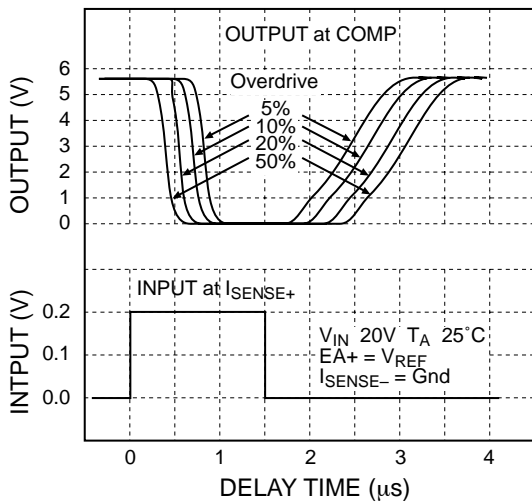

Turn-Off Delay From Shutdown

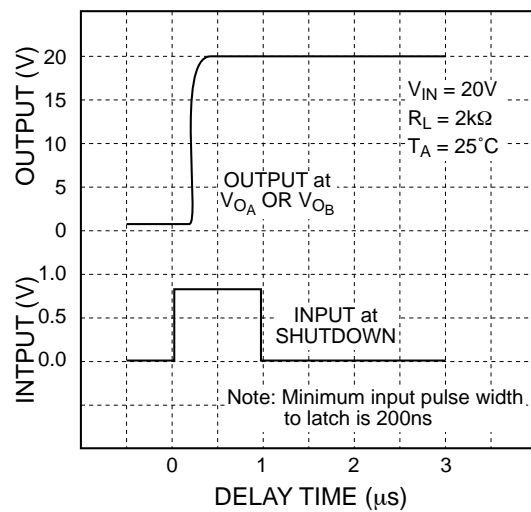

Output Saturation Voltage vs. Output Current Over Temperature

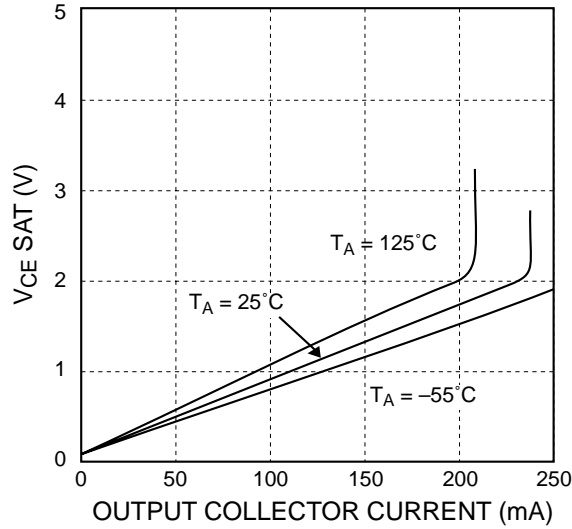

Open Loop Test Circuit

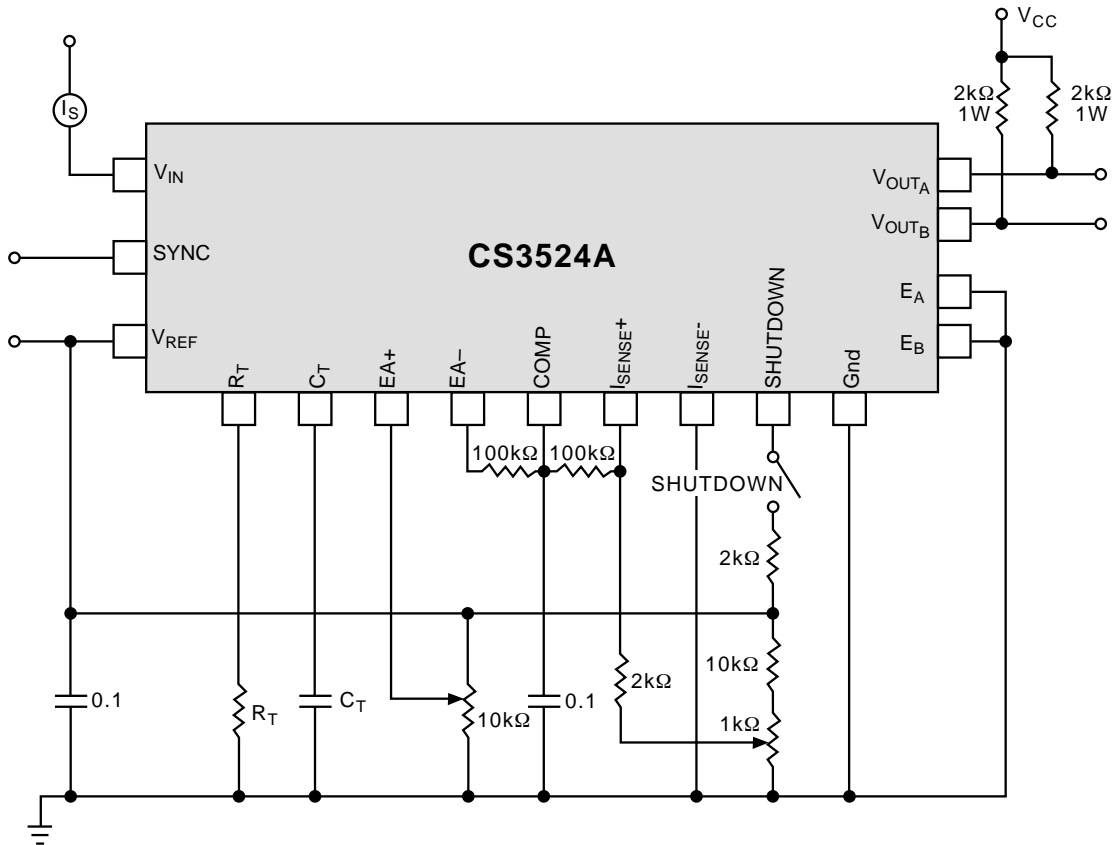

Note: The CS3524A should be able to be tested in any 3524 test circuit with two possible exceptions:

1. The higher gain-bandwidth of the current limit amplifier in the CS 3524A may cause oscillations in an uncompensated 3524 test circuit.
2. The effect of the shutdown, cannot be seen at the compensation terminal, but must be observed at the outputs.

Package Specification

PACKAGE DIMENSIONS IN mm (INCHES)

Lead Count	D			
	Metric		English	
	Max	Min	Max	Min
16 Lead PDIP	19.69	18.67	.775	.735
16L SO Wide	10.50	10.10	.413	.398

PACKAGE THERMAL DATA

Thermal Data		16 Lead PDIP	16L SO Wide	
$R_{\theta JC}$	typ	42	23	°C/W
$R_{\theta JA}$	typ	80	105	°C/W

Plastic DIP (N); 300 mil wide

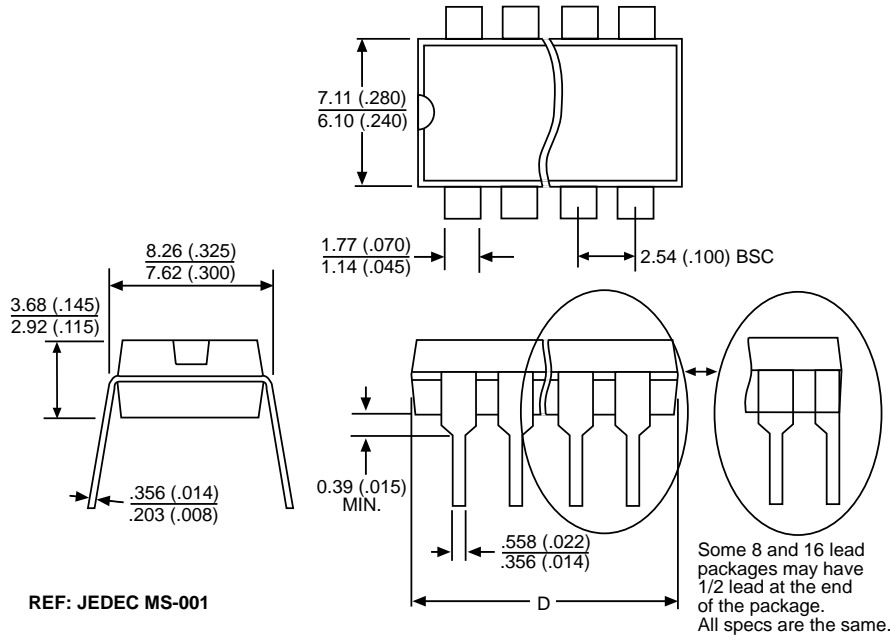

Surface Mount Wide Body (DW); 300 mil wide

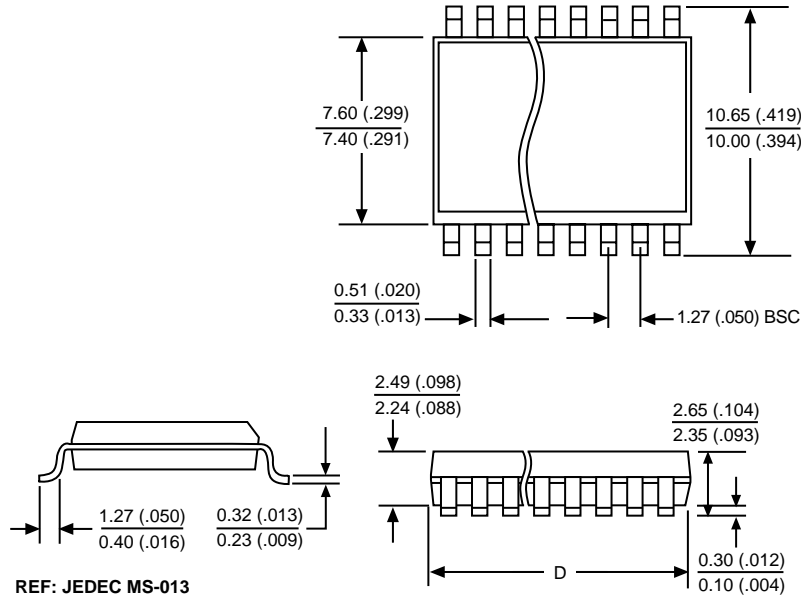

Ordering Information

Part Number	Description
CS3524AGN16	16 Lead PDIP
CS3524AGDW16	16 Lead SO Wide
CS3524AGDWR16	16 Lead SO Wide (tape & reel)

Cherry Semiconductor Corporation reserves the right to make changes to the specifications without notice. Please contact Cherry Semiconductor Corporation for the latest available information.