

# PTF 10139

## 60 Watts, 860-960 MHz

### GOLDMOS<sup>®</sup> Field Effect Transistor

#### Description

The PTF 10139 is a GOLDMOS FET intended for amplifier applications to 860-960 MHz. This 60-watt device operates at 55% efficiency with 12.5 dB typical gain. Nitride surface passivation and full gold metallization ensure excellent device lifetime and reliability.

- Performance at 960 MHz, 28 Volts
  - Output Power = 60 Watts Min
  - Power Gain = 12.5 dB Typ
  - Efficiency = 55% Typ
- Full Gold Metallization
- Silicon Nitride Passivated
- Excellent Thermal Stability
- Back Side Common Source
- 100% Lot Traceability
- Available in Package 20256 as PTF 10138

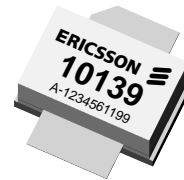
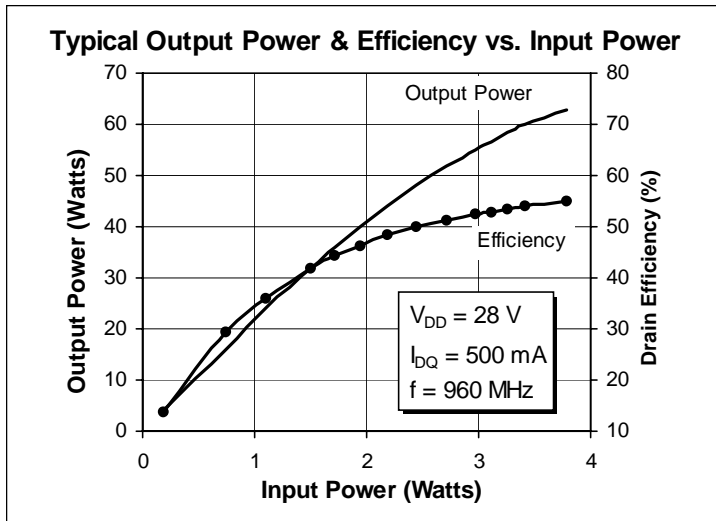

Package 20251

Also available in Package 20256

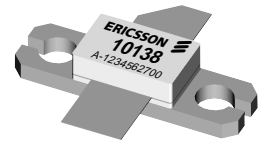

#### RF Specifications (100% Tested)

Characteristic	Symbol	Min	Typ	Max	Units
<b>Common Source Power Gain</b> ( $V_{DD} = 28\text{ V}$ , $P_{OUT} = 60\text{ W}$ , $I_{DQ} = 500\text{ mA}$ , $f = 960\text{ MHz}$ )	$G_{ps}$	11.5	12.5	—	dB
<b>Power Output at 1 dB Compression</b> ( $V_{DD} = 28\text{ V}$ , $I_{DQ} = 500\text{ mA}$ , $f = 960\text{ MHz}$ )	P-1dB	60	—	—	Watts
<b>Drain Efficiency</b> ( $V_{DD} = 28\text{ V}$ , $P_{OUT} = 60\text{ W}$ , $I_{DQ} = 500\text{ mA}$ , $f = 960\text{ MHz}$ )	$\eta$	50	55	—	%
<b>Load Mismatch Tolerance</b> ( $V_{DD} = 28\text{ V}$ , $P_{OUT} = 60\text{ W}$ , $I_{DQ} = 500\text{ mA}$ , $f = 960\text{ MHz}$ — all phase angles at frequency of test)	$\Psi$	—	—	10:1	—

All published data at  $T_{CASE} = 25^{\circ}\text{C}$  unless otherwise indicated.

## Electrical Characteristics (100% Tested)

Characteristic	Conditions	Symbol	Min	Typ	Max	Units
Drain-Source Breakdown Voltage	$V_{GS} = 0\text{ V}, I_D = 25\text{ mA}$	$V_{(BR)DSS}$	65	—	—	Volts
Drain-Source Leakage Current	$V_{DS} = 28\text{ V}, V_{GS} = 0\text{ V}$	$I_{DSS}$	—	—	1.0	mA
Gate-Source Leakage Current	$V_{GS} = 20\text{ V}, V_{DS} = 0\text{ V}$	$I_{GSS}$	—	—	1	$\mu\text{A}$
Gate Threshold Voltage	$V_{DS} = 10\text{ V}, I_D = 75\text{ mA}$	$V_{GS(th)}$	3.0	—	5.0	Volts
Forward Transconductance	$V_{DS} = 10\text{ V}, I_D = 3\text{ A}$	$g_{fs}$	—	2.8	—	Siemens

## Maximum Ratings

Parameter	Symbol	Value	Unit
Drain-Source Voltage	$V_{DS}$	65	Vdc
Gate-Source Voltage	$V_{GS}$	$\pm 20$	Vdc
Drain Current - Continuous	$I_D$	7	Adc
Operating Junction Temperature	$T_J$	200	$^{\circ}\text{C}$
Total Device Dissipation Above 25 $^{\circ}\text{C}$ derate by	$P_D$	194 1.11	Watts W/ $^{\circ}\text{C}$
Storage Temperature Range	$T_{STG}$	-65 to 150	$^{\circ}\text{C}$
Thermal Resistance ( $T_{CASE} = 70^{\circ}\text{C}$ )	$R_{\theta JC}$	0.9	$^{\circ}\text{C}/\text{W}$

## Typical Performance

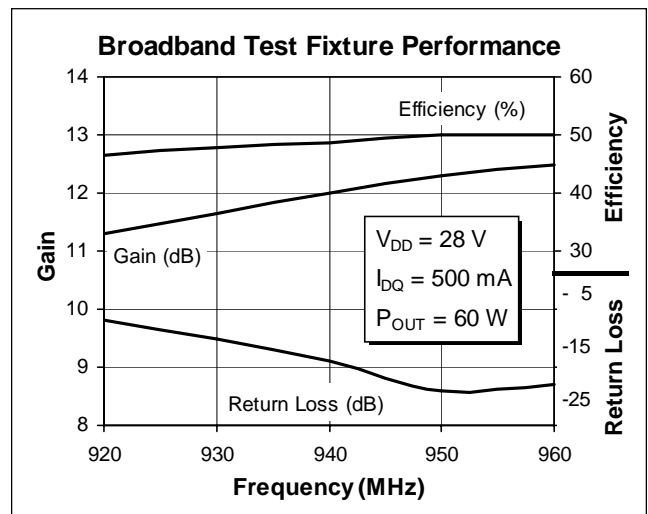
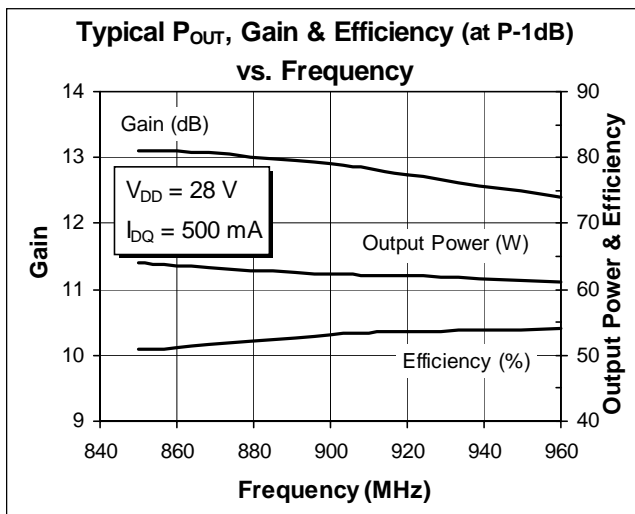

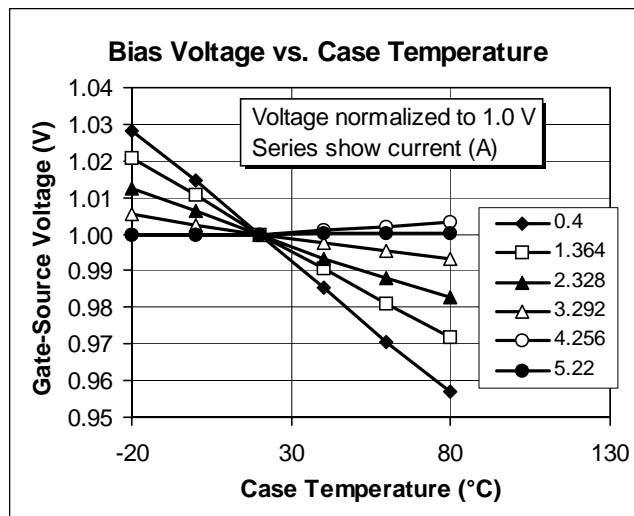
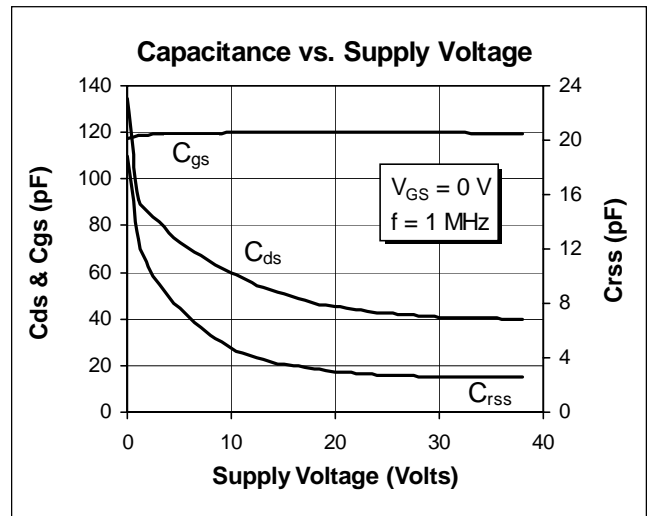
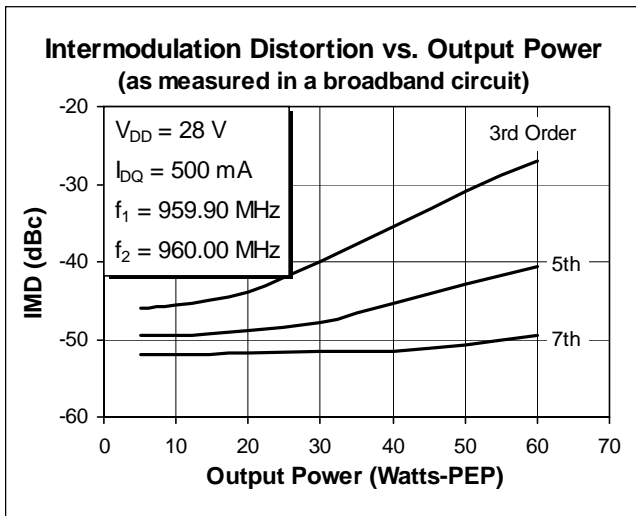
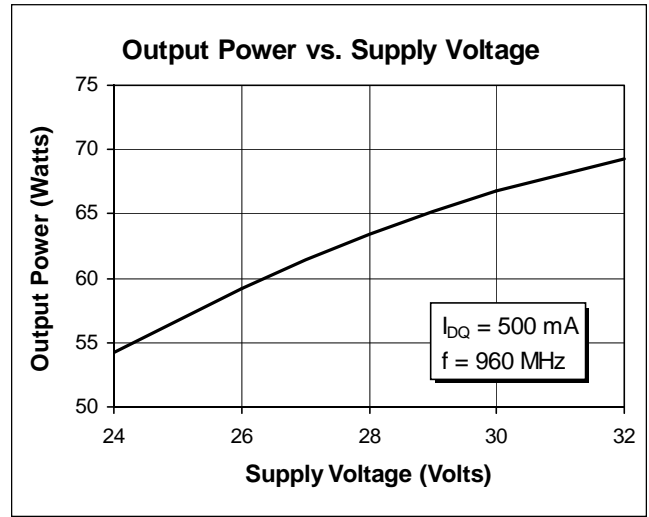
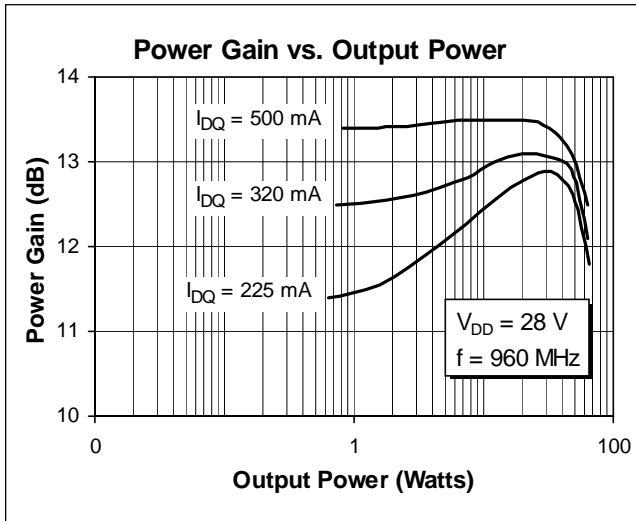

## Impedance Data

$V_{DD} = 28\text{ V}$ ,  $P_{OUT} = 60\text{ W}$ ,  $I_{DQ} = 500\text{ mA}$

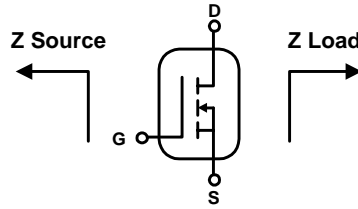

Frequency MHz	Z Source $\Omega$		Z Load $\Omega$	
	R	jX	R	jX
850	0.60	0.40	2.35	0.74
860	0.56	0.56	2.20	0.72
900	0.55	0.80	1.80	0.95
920	0.58	0.90	1.80	1.10
960	0.65	1.10	1.80	1.30

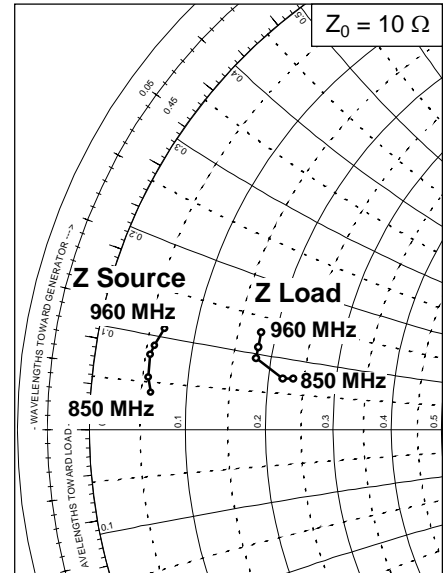

## Typical Scattering Parameters

$(V_{DS} = 28\text{ V}, I_D = 1.5\text{ A})$

f (MHz)	S11		S21		S12		S22	
	Mag	Ang	Mag	Ang	Mag	Ang	Mag	Ang
300	0.941	-175	2.70	36.8	0.028	-82.1	0.993	-175
350	0.949	-176	2.09	32.7	0.022	-82.7	0.990	-176
400	0.958	-178	1.71	28.3	0.017	-83.6	0.991	-178
450	0.968	-179	1.40	24.7	0.013	-82.9	0.994	-179
500	0.975	-179	1.20	22.3	0.009	-83.4	0.998	-179
550	0.973	180	1.03	18.0	0.006	-78.3	0.996	-180
600	0.974	179	0.892	14.6	0.003	-71.0	0.996	180
650	0.982	178	0.788	10.5	0.001	-19.9	0.996	179
700	0.985	177	0.671	6.38	0.003	44.0	0.997	178
750	0.981	177	0.576	3.31	0.004	68.8	0.999	178
800	0.979	176	0.489	0.641	0.007	71.9	0.996	177
850	0.986	175	0.425	0.228	0.008	70.1	0.990	176
900	0.984	175	0.378	0.643	0.010	76.6	0.992	176
950	0.986	174	0.342	-0.107	0.011	79.0	0.994	176
1000	0.992	173	0.316	-0.098	0.014	81.0	0.996	175
1050	0.990	173	0.294	-0.827	0.016	80.6	0.989	175
1100	0.983	172	0.264	-1.69	0.018	78.5	0.985	174
1150	0.984	171	0.245	-2.59	0.020	76.4	0.990	173
1200	0.993	171	0.228	-3.43	0.022	76.2	0.993	173
1250	0.991	171	0.211	-3.76	0.023	76.6	0.987	173
1300	0.986	170	0.192	-4.91	0.025	76.4	0.986	173
1350	0.982	169	0.179	-4.94	0.028	73.3	0.988	172
1400	0.990	169	0.173	-5.51	0.030	69.4	0.986	172
1450	0.991	169	0.159	-5.77	0.029	67.2	0.990	171
1500	0.986	168	0.146	-5.99	0.030	66.3	0.985	171

**Test Circuit**

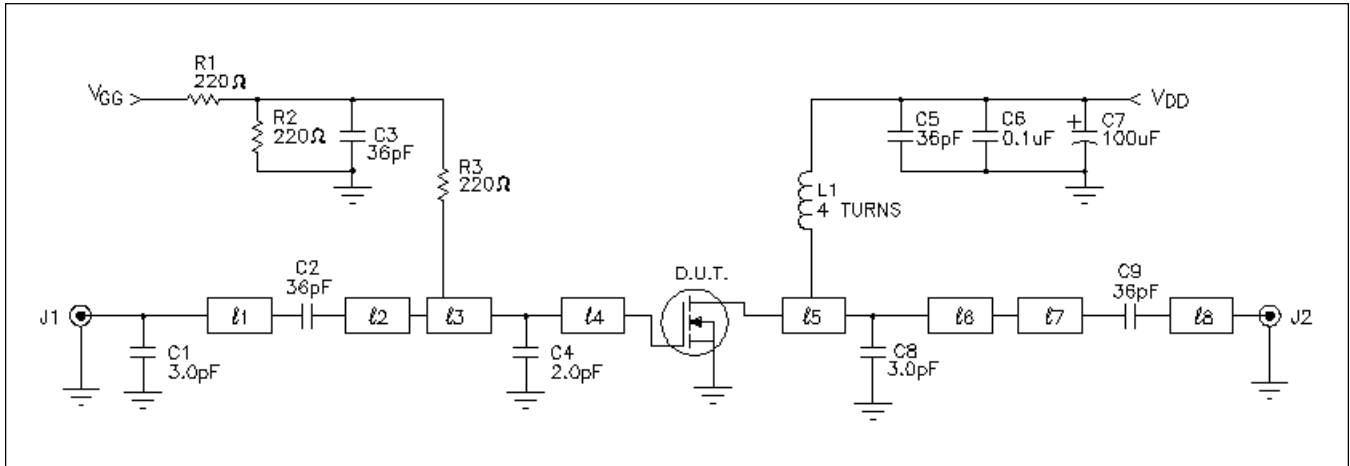

*Test Circuit Schematic for  $f = 960$  MHz*

D.U.T. PTF 10139

$l1$	$0.190 \lambda$ 960 MHz	Microstrip 50 $\Omega$
$l2$	$0.075 \lambda$ 960 MHz	Microstrip 15.7 $\Omega$
$l3$	$0.141 \lambda$ 960 MHz	Microstrip 5.2 $\Omega$
$l4$	$0.017 \lambda$ 960 MHz	Microstrip 5.2 $\Omega$
$l4$	$0.122 \lambda$ 960 MHz	Microstrip 8.3 $\Omega$
$l4$	$0.191 \lambda$ 960 MHz	Microstrip 8.3 $\Omega$
$l5$	$0.015 \lambda$ 960 MHz	Microstrip 50 $\Omega$
$l6$	$0.225 \lambda$ 960 MHz	Microstrip 50 $\Omega$

C1, C8	Capacitor, 3.0 pF	100 B 3r0
C2, C3, C5, C9	Capacitor, 36 pF	100 B 360
C4	Capacitor, 2.0 pF	100 B 2r0
C6	Capacitor, 0.1 $\mu$ F, 50 V	Digi-Key P4525-ND
C7	Capacitor, 100 $\mu$ F, 50 V	Digi-Key P5182-ND
J1, J2	Connector, SMA, Female, Panel Mount	Ericsson, #Rpm 513 412/53
L1	4 Turns, 22 Awg, .120 I.D.	
R1, R2, R3	Resistor, 220ohm, 1/4w	Digi-key 220qbk-no
Circuit Board	.031" thick, $\epsilon_r = 4.0$ , 2 Oz Copper, G200, Allied Signal	

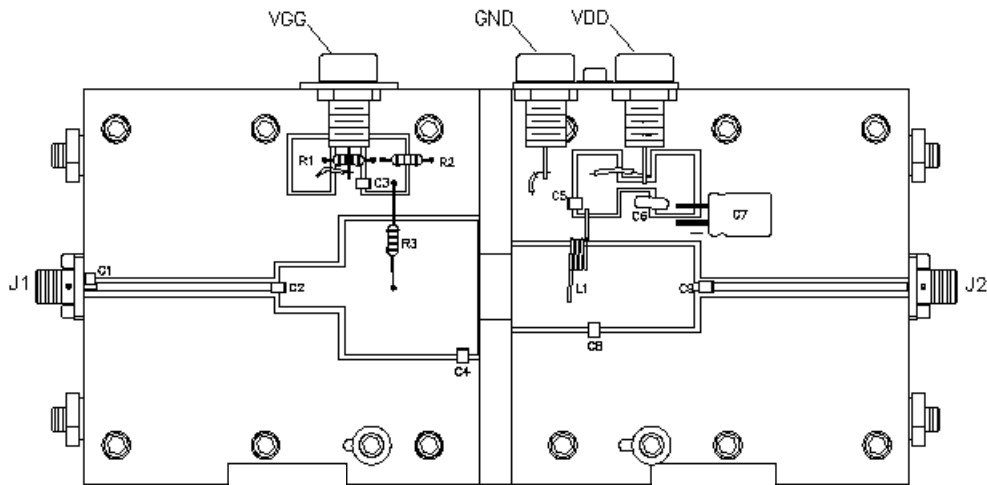

*Assembly Diagram (not to scale)*

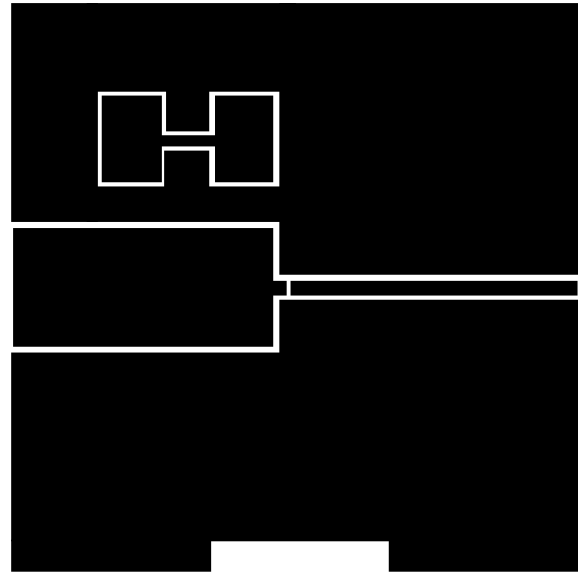
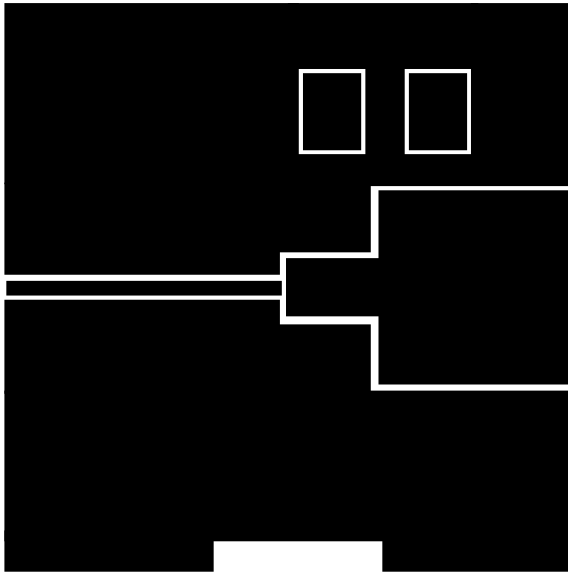

Artwork (not to scale)