

# MN655431SH

## Low Power 8-Bit CMOS A/D Converter for Image Processing

### ■ Overview

The MN655431SH is an 8-bit CMOS analog-to-digital converter with a maximum conversion rate of 15 MSPS.

It uses a half flash structure based on chopper comparators and achieves both high speed and low power consumption with multiplex processing.

It provides separate power supply pins for the circuits driving the low-voltage digital output pins.

### ■ Features

- Maximum conversion rate: 15 MSPS (min.)
- Linearity error:  $\pm 0.5$  LSB (typ.)
- Differential linearity error:  $\pm 0.4$  LSB (typ.)
- Power supply voltage: 4.40 to 5.25 V
- Power consumption: 90 mW (typ.)

### ■ Applications

- Digital television receivers
- Digital video equipment
- Digital image processing equipment

### ■ Pin Assignment

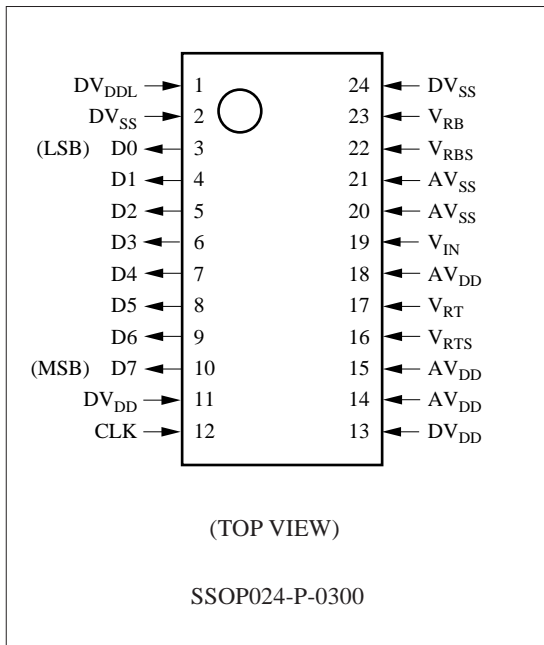

■ Block Diagram

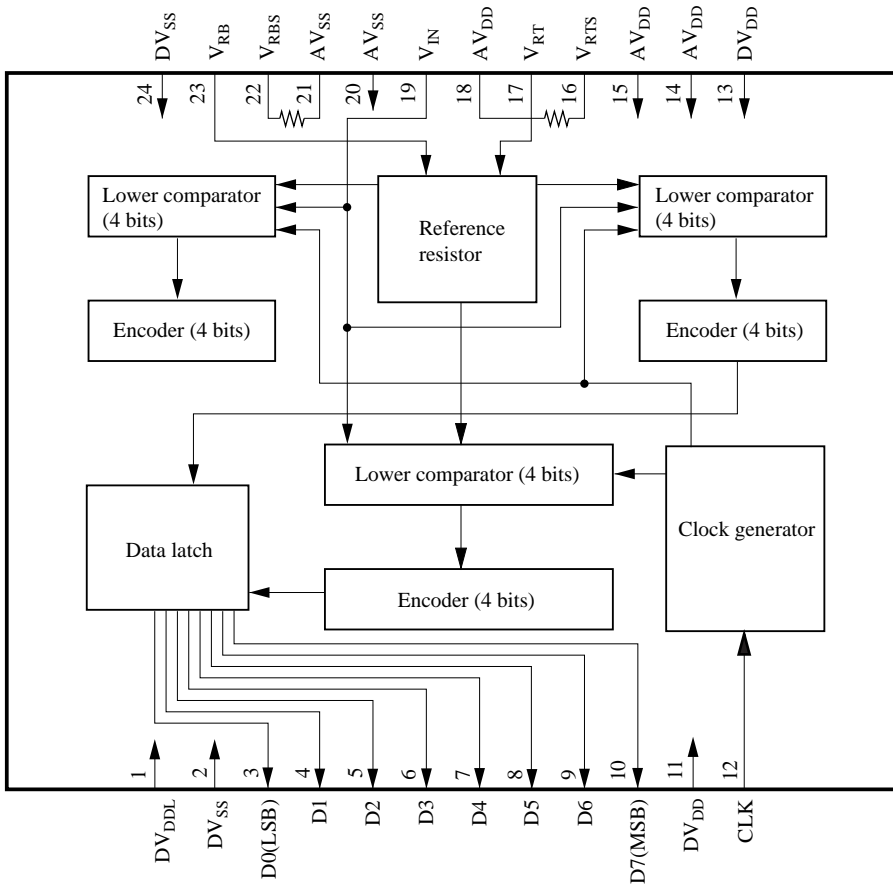

### ■ Pin Descriptions

Pin No.	Symbol	Function Description
1	DV <sub>DDL</sub>	Power supply for digital output circuits
2	DV <sub>SS</sub>	Ground for digital circuits
3	D0	Digital output (LSB)
4	D1	Digital output
5	D2	Digital output
6	D3	Digital output
7	D4	Digital output
8	D5	Digital output
9	D6	Digital output
10	D7	Digital output (MSB)
11	DV <sub>DD</sub>	Power supply for digital circuits
12	CLK	Sampling clock
13	DV <sub>DD</sub>	Power supply for digital circuits
14	AV <sub>DD</sub>	Power supply for analog circuits
15	AV <sub>DD</sub>	Power supply for analog circuits
16	V <sub>RTS</sub>	Power supply for reference voltage (TOP)
17	V <sub>RT</sub>	Reference voltage (TOP)
18	AV <sub>DD</sub>	Power supply for analog circuits
19	V <sub>IN</sub>	Analog input
20	AV <sub>SS</sub>	Ground for analog circuits
21	AV <sub>SS</sub>	Ground for analog circuits
22	V <sub>RBS</sub>	Power supply for reference voltage (BOTTOM)
23	V <sub>RB</sub>	Reference voltage (BOTTOM)
24	DV <sub>SS</sub>	Ground for digital circuits

### ■ Absolute Maximum Ratings $T_a=25^\circ\text{C}$

Parameter	Symbol	Rating	Unit
Power supply voltage	V <sub>DD</sub>	- 0.3 to +7.0	V
Power supply voltage for digital outputs	DV <sub>DDL</sub>	- 0.3 to +V <sub>DD</sub> +0.3	V
Input voltage	V <sub>I</sub>	AV <sub>SS</sub> - 0.3 to V <sub>DD</sub> +0.3	V
Output voltage	V <sub>O</sub>	DV <sub>SS</sub> - 0.3 to V <sub>DD</sub> +0.3	V
Operating ambient temperature	T <sub>opr</sub>	-20 to +70	°C
Storage temperature	T <sub>stg</sub>	-55 to +125	°C

**Recommended Operating Conditions**  $V_{DD}=AV_{DD}=DV_{DD}=5.0V$ ,  $DV_{DDL}=3.5V$ ,  $V_{SS}=AV_{SS}=DV_{SS}=0V$ ,  $T_a=25^{\circ}C$ 

Parameter		Symbol	min	typ	max	Unit
Power supply voltage		$V_{DD}$	4.50	5.00	5.25	V
Power supply voltage for digital outputs		$DV_{DDL}$	3.4		3.6	V
Digital input voltage	"H" level	$V_{IH}$	2.4		$V_{DD}$	V
	"L" level	$V_{IL}$	$V_{SS}$		0.8	V
Reference voltage	"H" level	$V_{RT}$	3.3		$V_{DD}$	V
	"L" level	$V_{RB}$	$V_{SS}$		1.5	V
Clock	"H" level pulse width	$t_{WH}$	30			ns
	"L" level pulse width	$t_{WL}$	30			ns
Analog input voltage		$V_{AIN}$	$V_{SS}$		$V_{DD}$	V

**Electrical Characteristics**  $V_{DD}=AV_{DD}=DV_{DD}=5.0V$ ,  $DV_{DDL}=3.5V$ ,  $AV_{SS}=DV_{SS}=0V$ ,  $T_a=25^{\circ}C$ 

Parameter		Symbol	Conditions	min	typ	max	Unit
Power supply voltage		$I_{DD}$	$f_{CLK} = 15 \text{ MHz}$ (includes reference power supply)		18	26	mA
Resolution		RES			8		bit
Linearity error		$E_L$	$f_{CLK}=15\text{MHz}$		$\pm 0.5$	$\pm 1.3$	LSB
Differential linearity error		$E_D$	$V_{RT}=3.5V$ $V_{RB}=1.5V$		$\pm 0.4$	$\pm 0.7$	LSB
Maximum conversion rate		$F_{c(max.)}$		15			MSPS
Clock frequency		$f_{CLK}$		1		15	MHz
Analog input dynamic range		$D_R$		2		$V_{RT}-V_{RB}$	V
Output current	"H" level	$I_{OH}$	$V_{OH}=DV_{DDL} - 0.8V$			-2	mA
	"L" level	$I_{OL}$	$V_{OL}= 0.4V$	2			mA
Output delay time		$t_d$			30	45	ns
Analog input capacitance		$C_I$			18		pF

**■ Timing Chart**

The chip samples the analog input at the falling edge of the clock signal and provides the corresponding digital output 2.5 clock cycles later at the rising edge of the clock signal.

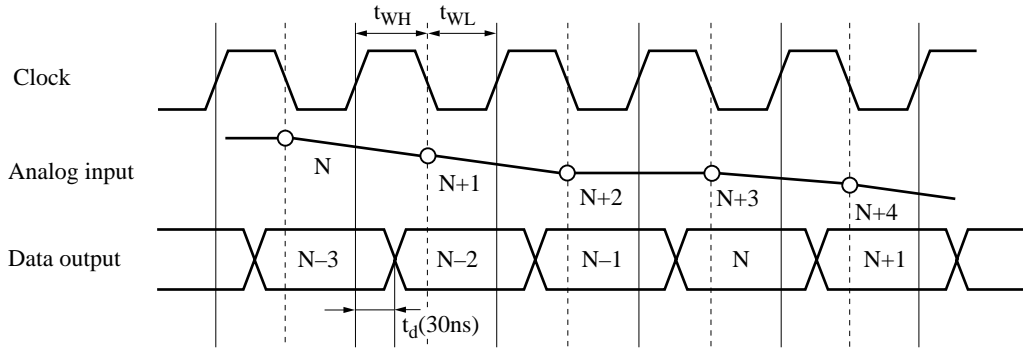

Note: The circles indicate analog signal sampling points.

■ Package Dimensions (Unit:mm)

SSOP024-P-0300

