

TMC2242C

Digital Half-Band Interpolating/Decimating Filter 12-bit In/16-bit Out, 60 MHz

Features

- Pin-compatible upgrade of TMC2242B
- User-selectable interpolate d.c. gain, 0 dB or -6 dB
- True unity d.c. gain in all “0 db” modes
- 40 MSPS performance in equal-rate filter modes
- 40 and 60 MSPS speed grades in all other modes
- User-selectable 2:1 decimation, 1:2 interpolation, and equal-rate filter modes, plus unfiltered bypass/delay mode
- Defeatable $\pi x/\sin(\pi x)$ compensation filter
- Passband ripple <0.014 dB
- Stopband rejection >56 dB
- Dedicated 12-bit two’s complement or unsigned input bus
- 16-bit two’s complement or unsigned output bus with user-selectable rounding to 8 to 16 effective bits
- Programmable limiter prevents overflow or clips to CCIR601 levels
- New double-latency modes match Y channel data flow to slower-sampled C_B and C_R data flows
- New dual-channel interpolation and decimation for YUV422

Applications

- Digital-to-Analog Converter Prefiltering with optional $x/\sin x$ correction
- 1:2 interpolation
- Analog-to-Digital Converter Postfiltering
- 2:1 decimation
- Low-ripple low-pass (0 to 0.2 f_s) filter

Description

The TMC2242C, a linear-phase low-pass half-band digital filter with fixed coefficients, can be used to halve or double the sampling rate of a digital signal. When used as a decimating post-filter with a double-speed oversampling A/D converter, it greatly reduces the cost and complexity of the required analog antialiasing pre-filters. When used as an interpolating pre-filter with a double-speed oversampling D/A converter, it greatly reduces the complexity and cost of the necessary analog post-filter, particularly when its $x/\sin(x)$ correction filter is engaged.

The TMC2242C user selects the mode of operation (decimate, interpolate, equal-rate, bypass, $x/\sin(x)$) and rounding. The part can accept 12-bit two’s complement or unsigned data at up to 60 MHz and can output saturated two’s complement or offset binary data rounded to from 8 to 16 bits. Within the speed grade I/O limit, the output sample rate may be 1/2, 1, or 2 times the input sample rate. Two-channel modes permit it to interpolate or to decimate two multiplexed data streams (such as video C_B and C_R) jointly.

The filter response is flat to within ± 0.014 dB up to $0.21f_s$ (e.g. 5.75MHz at a 27MHz clock rate), with stopband attenuation greater than 56dB above $0.29f_s$. Symmetric-coefficient filters such as the TMC2242C always have linear phase response. Half-band response is -6 dB.

Fabricated on an advanced submicron CMOS process, the TMC2242C is available in a 44-lead PLCC package. Performance is guaranteed from 0 to 70°C and over a power supply range of 4.75 to 5.25V.

Block Diagram

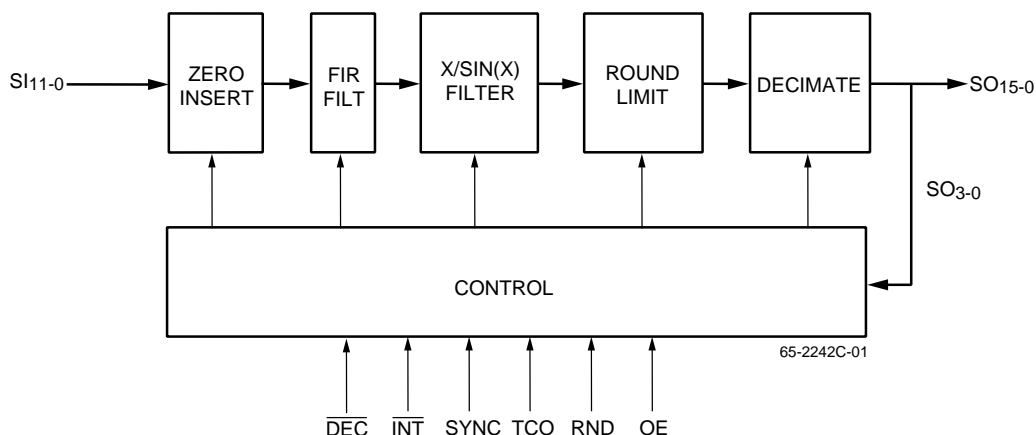

Functional Description

The TMC2242C implements a fixed-coefficient linear-phase Finite Impulse Response (FIR) filter, with special rate-matching input and output structures for decimation and interpolation. For parts of each speed grade, the faster of either the input or the output bus will operate at the respective guaranteed maximum clock rate. The total internal pipeline latency from the input of an impulse to the corresponding output peak (digital group delay) is 34 clock cycles; the 39-value output response begins after 15 clock cycles and ends after 53 cycles. (The double-latency interpolation and decimation modes feature group delays of 68 clock cycles.)

To interpolate, the chip accepts incoming data on alternate clock cycles, inserting zeroes on the remaining clock cycles. In decimation mode, the chip’s output register is strobed at half the clock rate. In bypass and equal-rate filter modes, these input zero insertion and output register hold functions are disabled.

When interpolating, the user should normally bring SYNC HIGH for at least one clock cycle, returning it LOW with the first desired input data value. The chip will then continue to accept data on alternate rising edges of CLK. The user may leave SYNC LOW or change its value once per clock cycle, with equivalent results. The chip can be powered up and operated with SYNC grounded, but the input-to-output latency may vary by 1/2 input sample period and the host system won’t know which (even- or odd-numbered) CLK rising edges strobe the input register. The setup and hold timing requirements for SYNC, with respect to the rising edges of CLK, are the same as those for all other data and control inputs except OE, which is asynchronous. In two-channel mode, it must remain low after the first incoming data value.

When decimating, the user should likewise bring SYNC HIGH for at least one clock cycle, returning it LOW when a fresh output is desired. The chip will continue to update the output register on alternate rising edges of CLK. The user may leave SYNC LOW or change its value once per clock cycle, with equivalent results. The chip can be powered up and operated with SYNC grounded, but the host system won’t know whether the data outputs are updated on even- or odd-numbered system clock cycles. In any half-band decimating filter, a given single-cycle impulse’s arrival time (on an odd versus an even clock cycle) determines whether it generates a half-amplitude two-cycle impulse or a half-speed, 40-clock, filtered output shaped by the nonzero, non-center coefficients. The SYNC control permits the host system to obtain consistent results. In two-channel mode, it must remain low after the first incoming data value.

When the result is rounded to fewer than 16 bits, the unneeded lowest positions of the output bus are tristated and become supplementary control bits, which enable the $x/\sin(x)$ filter, bypass/delay, double-latency, dual-channel,

and other special modes. Unless more than 12 output bits are enabled, the TMC2242C offers $x/\sin(x)$ correction filtering, with or without the main low-pass filter, and without impacting the 34-cycle group delay. Bidirectional pins SO3-2 enable these modes, per Table 1. If 14 or more output bits are used, the low pass filter remains enabled, the $x/\sin(x)$, disabled.

Table 1. Operating Modes

INT	DEC	RND2	SO3-2	Function
0	0	0	Output	Interpolate (0 dB)
0	1	0	Output	Interpolate ¹ (-6 dB)
1	0	0	Output	Decimate
1	1	0	Output	Equal Rate Lowpass
0	0	1	00	Interpolate (0 dB)
0	1	1	00	Interpolate ¹ (-6 dB)
1	0	1	00	Decimate
1	1	1	00	Equal Rate Lowpass
0	0	1	01	Interpolate (0 dB) * $x/\sin x$
0	1	1	01	Interpolate ¹ (-6 dB) * $x/\sin x$
1	0	1	01	Decimate * $x/\sin x$
1	1	1	01	Equal Rate LPF * $x/\sin x$
0	0	1	10	Delay + Interpolate ² (0 dB)
0	1	1	10	Delay + Interpolate ² (0 dB) * $x/\sin x$
1	0	1	10	Delay + Decimate ²
1	1	1	10	Bypass (Delay Only)
0	0	1	11	2-Channel Interpolate ³ (0 db)
0	1	1	11	2-Channel Interpolate ³ * $x/\sin x$
1	0	1	11	2-Channel Decimate ³
1	1	1	11	Delay * $x/\sin x$

Note:

1. These modes limit to 15 bits (SO14-0) instead of 16 (SO15-0) and are provided for backward compatibility to earlier parts.
2. These modes, which double the chip’s overall group delay from 34 to 68 CLK cycles, can be used to equalize inter-component delays where Y is sampled at twice the rate of CB or CR (e.g. 4:2:2 and 8:4:4 formats).
3. These modes accommodate multiplexed two-channel data, e.g. CB/CR.

Table 2. Package Interconnections

Signal Type	Name	Function	PLCC Pin	MQFP Pin
Timing	CLK	Clock	42	36
	SYNC	Synchronization	43	37
Data In	SI11-0	Input Data Port	40, 37-30, 27-25	34, 31-24, 21-19
Data Out	SO15-4	Output Data Port	4-11, 14-17	42-44, 1-5, 8-11
Dual-Function Controls	SO3-0	Output Data; Controls	18-21	12-15
	$\overline{\text{INT}}$	Interpolate	44	38
	$\overline{\text{DEC}}$	Decimate	1	39
	RND2-0	Rounding Position	22-24	16-18
	TCO	Output Format	2	40
	OE	Output Enable	3	41

The output data format is two's complement if TCO is HIGH, inverted or offset binary if LOW. Unless all 16 output bits are used, the user can also select either signed or unsigned input data, via pin SO₀ (see pin description note 2, below). As shown in pin description note 1, the output is half-LSB rounded to the resolution selected by the value of RND₂₋₀. The asynchronous three-state output enable control simplifies connection to a data bus with other drivers.

Pin Assignments

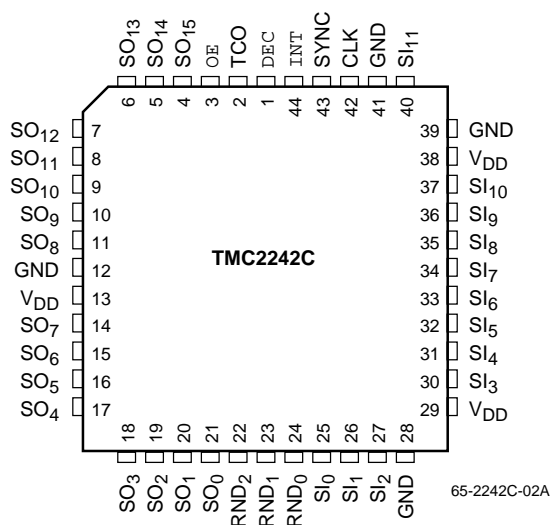

44 Lead PLCC

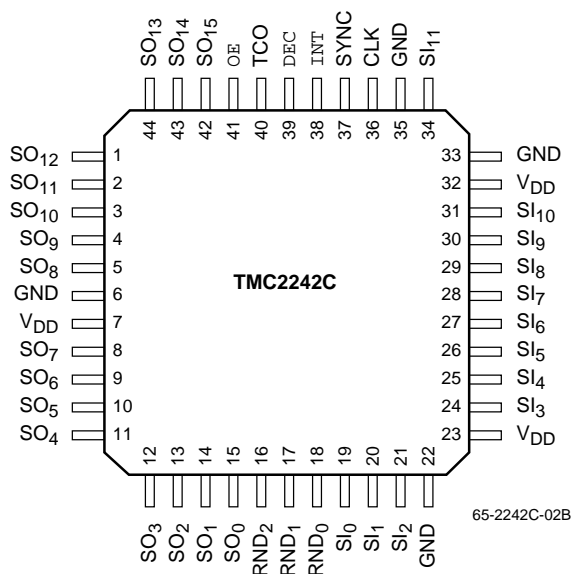

44 Lead MQFP

Pin Descriptions

Pin Name	Pin Number		Pin Function Description
	PLCC	MQFP	
Dedicated Timing Controls			
CLK	42	36	Clock. The chip operates from a single-phase master clock, to whose rising edges all timing parameters are referenced. All internal registers are strobed on every rising edge of CLK, although the output register is strobed on alternate rising edges during decimation. In all modes, the frequency applied to CLK is the higher of the input and output data sampling rates. During interpolation, the chip reads its input bus on alternate rising edges of CLK.
SYNC	43	37	Synchronization. During interpolation, the chip accepts input data on alternate rising edges of CLK and inserts zeroes on the remaining cycles. If SYNC is HIGH during CLK rising edge 0 and LOW during CLK rising edge 1, the chip will accept data on CLK 1 and insert a zero on CLK 2. Thereafter, if SYNC is either held LOW or fed a square wave of half the CLK frequency, the part will continue to accept data on odd-numbered CLK edges and to stuff zeroes on even-numbered edges. Similarly, during decimation, the output data change only on alternate clock cycles. If the user operates SYNC as above, each even-numbered rising edge of CLK will trigger a change in the output. In all other modes, the state of SYNC doesn't affect operation of the chip.
Dedicated Data Input Port			
SI11-0	40, 37-30, 27-25	34, 31-24, 21-19	Input Data. A 12-bit two's complement or unsigned input word is registered by the rising edges of CLK. SI0 is the LSB.
Dedicated Data Output Port			
SO15-0	4-11, 14-21	42-44, 1-5, 8-15	Output Data MSBs. When \overline{OE} is LOW, the 12 most significant bits of the filter's output emerge here, following each rising edge of CLK. The format may be two's complement, unsigned, or inverted offset binary. Bits SO15-4 correspond to input bits SI11-0, respectively. An on-chip limiter prevents overflows and underflows in the output data.
Dual Function Data Output/Control Input Pins			
SO3-2			Output Data. These pins serve as data outputs when RND2 is LOW. When RND2 is HIGH, they become additional filter mode controls (Table 1).
SO1			Output Data 2nd LSB. This pin is a data output when RND2-1 are LOW. When either RND2 or RND1 is HIGH, it becomes an additional rounding control. ¹
SO0			Output Data LSB. This pin is a data output if and only if all RND bits are LOW. Otherwise, it augments the data I/O format controls. ²
Dedicated Static Controls (Set state before first desired data input.)			
\overline{INT} , \overline{DEC}	44, 1	38, 39	Interpolate and Decimate. Jointly with SO3-2, these bits select the chip's overall operating mode, as discussed earlier in Table 1
TCO	2	40	Output format control. When TCO is HIGH, the output data are in two's complement format. When TCO is LOW, they are inverted offset binary, unless SO0 is HIGH and RND is nonzero, in which case they are unsigned.
RND2-0	22-24	16-18	Round and output tristate. Selects output rounding position and active bus width 8-16 bits. All outputs at and below the rounding bit position are tristated, allowing the 4 LSBs to become control inputs.
Active, Asynchronous Control			
\overline{OE}	3	41	Output enable. LOW activates output bus from SO15 down to the effective LSB, as chosen by RND2-0. All drivers at and below the rounding point are disabled, as are all drivers when \overline{OE} is HIGH.

Notes:

1. Rounding Operation Detail

RND2-0	SO1	Output Rounding
000	Output ^A	SO15-0 (16 bits)
001	Output ^A	SO15-1 (15 bits)
010	X	SO15-2 (14 bits)
011	X	SO15-3 (13)
100	0	SO15-4 (12)
100	1	SO15-8 (8)
101	0	SO15-5 (11)
110	1	SO15-6 (10)
111	X	SO15-7 (9)

A. If RND2-0 = 00X, do not drive SO1, externally.

2. I/O Format Operation Detail

RND	SO0	TCO	In Format	Out Format
0	Output	0	2's Comp	Inverted Offset
0	Output	1	2's Comp	2's Comp
>0	0	0	2's Comp	Inverted Offset
>0	0	1	2's Comp	2's Comp
>0	1	0	Unsigned	Unsigned
>0	1	1	Unsigned	2's Comp

Absolute Maximum Ratings

(beyond which the device may be damaged)¹

Parameter	Conditions	Min	Max	Units
Supply Voltage		-0.5	7.0	V
Input Voltage		-0.5	VDD + 0.5	V
Output Applied Voltage ²		-0.5	VDD + 0.5	V
Externally Forced Current ^{3,4}		-3.0	+6.0	mA
Short Circuit Duration	Single output in HIGH state to ground		1	sec
Operating Temperature (Case)		-20	110	°C
Junction Temperature			140	°C
Lead Soldering Temperature	10 seconds		300	°C
Storage Temperature		-65	150	°C

Notes:

- Functional operation under any of these conditions is NOT implied. Performance and reliability are guaranteed only if Operating Conditions are not exceeded.
- Applied voltage must be current limited to specified range.
- Forcing voltage must be limited to specified range.
- Current is specified as conventional current flowing into the device.

Operating Conditions

		Conditions	Min	Nom	Max	Units
V _{DD}	Power Supply Voltage		4.75	5.0	5.25	V
f _{CLK}	Clock frequency	TMC2242C			40	MHz
		TMC2242C-1			60	MHz
t _{PWH}	CLK pulse width, HIGH		6			ns
t _{PWL}	CLK pulse width, LOW		6			ns
t _S	Input Data Set-up Time		6			ns
t _H	Input Data Hold Time		0			ns
V _{IH}	Input Voltage, Logic HIGH		2.0			V
V _{IL}	Input Voltage, Logic LOW				0.8	V
I _{OH}	Output Current, Logic HIGH				-2.0	mA
I _{OL}	Output Current, Logic LOW				4.0	mA
T _A	Ambient Temperature, Still Air		0		70	°C

Electrical Characteristics

Parameter		Conditions	Min	Typ	Max	Units
I _{DD}	Total Power Supply Current	V _{DD} = Max, C _{LOAD} =25pF, f _{CLK} =Max				
		TMC2242C			150	mA
		TMC2242C-1			220	mA
I _{DDU}	Power Supply Current, Unloaded	V _{DD} = Max, \overline{OE} = HIGH, f _{CLK} =Max				
		TMC2242C			135	mA
		TMC2242C-1			200	mA
I _{DDQ}	Power Supply Current, Quiescent	V _{DD} = Max, CLK = LOW			5	mA
C _{PIN}	I/O Pin Capacitance			5		pF
I _{IH}	Input Current, HIGH	V _{DD} = Max, V _{IN} = V _{DD}			±10	μA
I _{IH} (PD)	Input Current, HIGH (Pulldown SO0–SO3)	V _{DD} = Max, V _{IN} = V _{DD}			-10 +150	μA
I _{IL}	Input Current, LOW	V _{DD} = Max, V _{IN} = 0 V			±10	μA
I _{IOZH}	Leakage Current, HIGH	\overline{OE} = HIGH, V _{OUT} = V _{DD}			±10	μA
I _{IOZH} (PD)	Leakage Current, HIGH (Pulldown SO0–SO3)	\overline{OE} = HIGH, V _{OUT} = V _{DD}			-10 +150	μA
I _{IOZL}	Leakage Current, LOW	\overline{OE} = HIGH, V _{OUT} = 0 V			±10	μA
I _{OS}	Short-Circuit Current	V _{DD} = Max, Output = HIGH, one pin to ground, one second duration max.	-90		-150	mA
V _{OH}	Output Voltage, HIGH	SO15-0, I _{OH} = Max	2.4			V
V _{OL}	Output Voltage, LOW	SO15-0, I _{OL} = Max			0.4	V

Switching Characteristics

Parameter	Conditions	Min	Typ	Max	Units
t _{DO}	Output Delay Time	C _{LOAD} = 25 pF		15	ns
t _{HO}	Output Hold Time	C _{LOAD} = 25 pF	2.5		ns
t _{ENA}	Output Enable Time	C _{LOAD} = 0 pF		15	ns
t _{DIS}	Output Disable Time	C _{LOAD} = 0 pF		30	ns

Table 3a. Input Data Formats and Bit Weighting

Format	SI11	SI10	S9	...	SI1	S0
Two's Comp.	-2^0	2^{-1}	2^{-2}	...	2^{-10}	2^{-11}
Unsigned	2^0	2^{-1}	2^{-2}	...	2^{-10}	2^{-11}

Table 3b. Output Data Formats and Bit Weighting

Format	SO15	SO14	SO13	...	SO5	SO4
Two's Comp.	-2^0	2^{-1}	2^{-2}	...	2^{-10}	2^{-11}
Unsigned ¹	2^0	2^{-1}	2^{-2}	...	2^{-10}	2^{-11}
-6 dB t.c. ²	-2^0	-2^0	2^{-1}	...	2^{-9}	2^{-10}
-6 dB Unsgn ³	0	2^0	2^{-1}	...	2^{-9}	2^{-10}

Notes:

1. Inverted offset binary is the same as unsigned, except that all bits are complemented.
2. In -6 dB interpolation modes, the two's complement sign bit is replicated in SI15 and SI14.
3. In -6 dB interpolation mode, the unsigned MSB is preceded by a 0 in SO15.
4. A leading minus sign denotes the two's complement sign bit.
5. In all operating modes except "interpolate -6 dB," dc gain is exactly unity.

Table 4. Rounded LSBs as a function of RND2-0

													RND2-0
SO15	SO14	SO13	...	SO8	SO7	SO6	SO5	SO4	SO3	SO2	SO1	SO0r	000
SO15	SO14	SO13	...	SO8	SO7	SO6	SO5	SO4	SO3	SO2	SO1r	z	001
SO15	SO14	SO13	...	SO8	SO7	SO6	SO5	SO4	SO3	SO2r	z	z	010
SO15	SO14	SO13	...	SO8	SO7	SO6	SO5	SO4	SO3r	z	z	z	011
SO15	SO14	SO13	...	SO8	SO7	SO6	SO5	SO4r	z	z	z	z	100 ²
SO15	SO14	SO13	...	SO8	SO7	SO6	SO5r	z	z	z	z	z	101
SO15	SO14	SO13	...	SO8	SO7	SO6r	z	z	z	z	z	z	110
SO15	SO14	SO13	...	SO8	SO7r	z	z	z	z	z	z	z	111

Note:

1. The "r" indicates that the trailing significant output bit has been rounded to the nearest 1/2 LSB. All output drivers at and below the rounding bit are disabled, allowing the lower output bits to be used as control inputs.
2. If SO1 = 1, format is 8 bits, viz: SO15...SO8r z...z.

Table 5. Steady-State Output Values and Limit Triggers

Input		Interpolate -6 dB		All Other Modes		Interpretation	
Unsigned	2's Comp.	Unsigned	2's Comp.	Unsigned	2's Comp.	Unsigned	2's Comp.
FFF	7FF	7FF8 ¹	3FF8 ¹	FFF0 ¹	7FF0 ¹	full-scale	full-scale +
C00	400	6000	2000	C000	4000	3/4-scale	1/2 scale +
801	001	4008	0008	8010	0010		1 LSB +
800	000	4000	0000	8000	0000	1/2-scale	Zero
7FF	FFF	3FF8	FFF8	7FF0	FFF0		1 LSB -
400	C00	2000	E000	4000	C000	1/4-scale	1/2-scale -
000	800	0000 ¹	C000 ¹	0000 ¹	8000 ¹	zero	full-scale -

Notes:

1. Full-scale values are minima and maxima permitted by on-chip limiter. Transient overshoots arising from large input signal transitions will be clipped to these limits.

Performance Curves

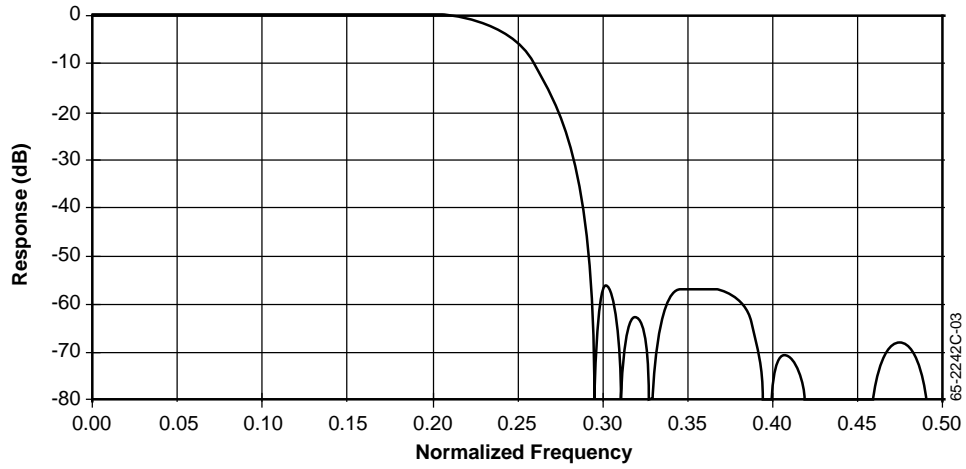

Figure 1. Frequency Response

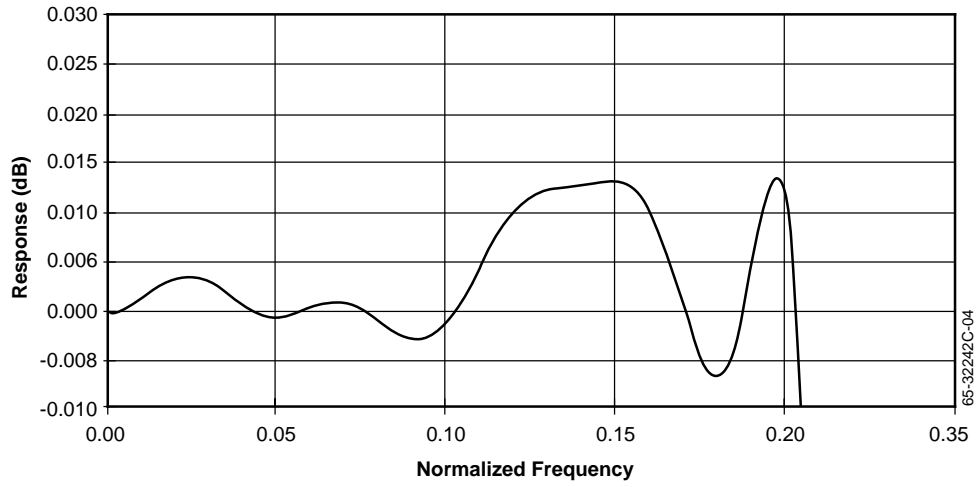

Figure 2. Passband Ripple Response

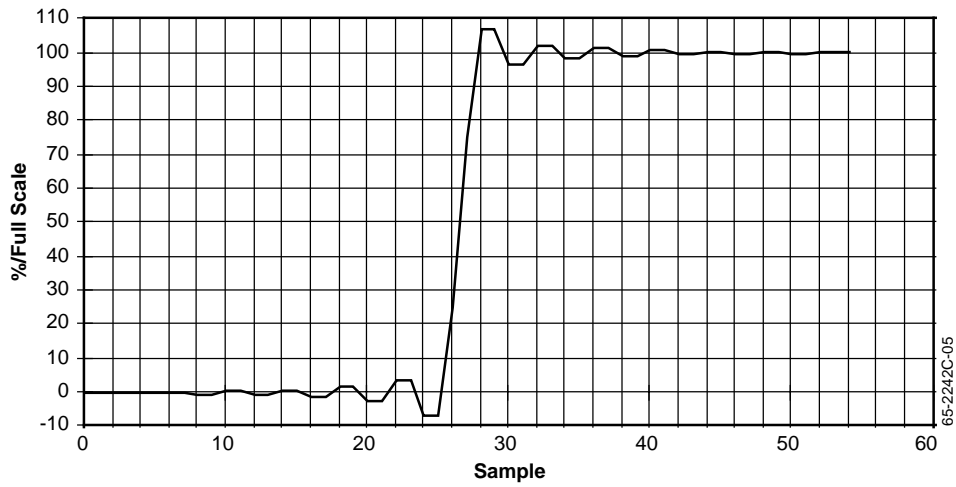

Figure 3. Step Response

Equivalent Circuits

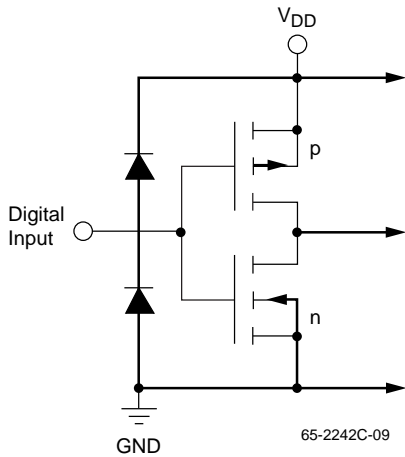

Figure 4. Equivalent Digital Input Circuit

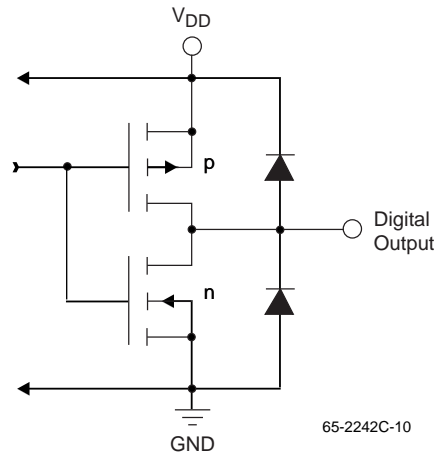
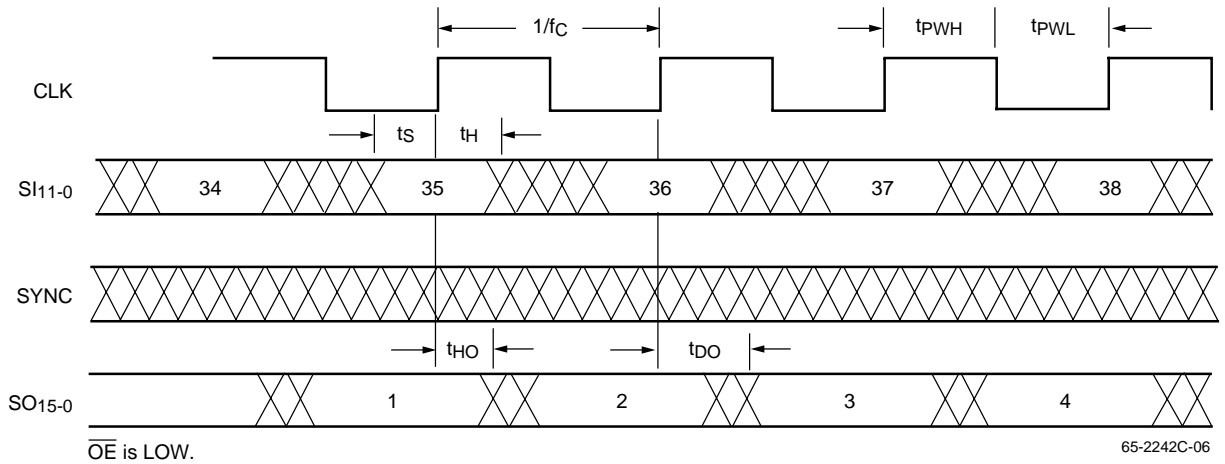

Figure 5. Equivalent Digital Output Circuit

Timing Diagrams



Note: Values at SO15-0 are impulse response centers (peaks) corresponding to same-numbered inputs.

Figure 6. Equal Rate Mode

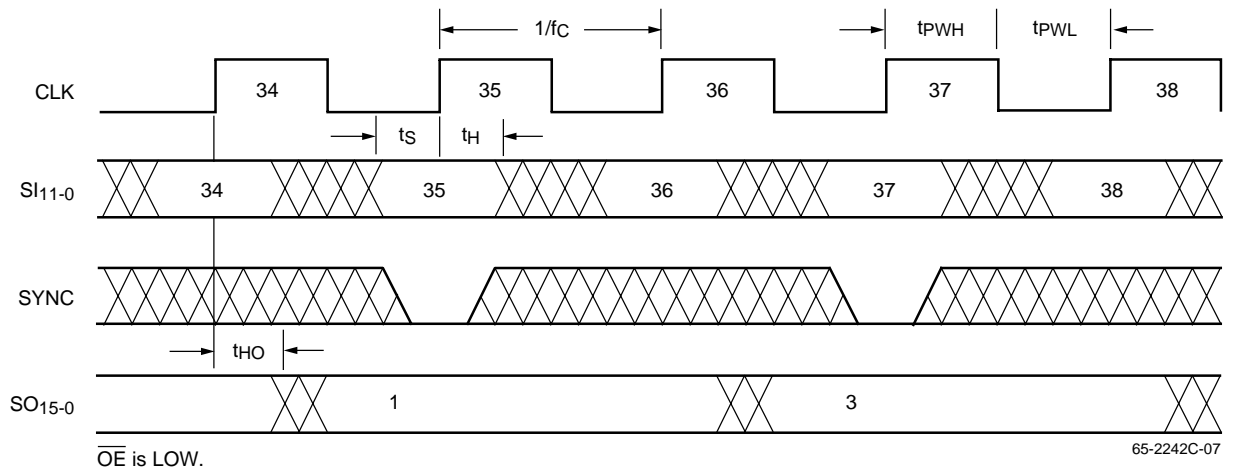

Figure 7. Decimate Mode

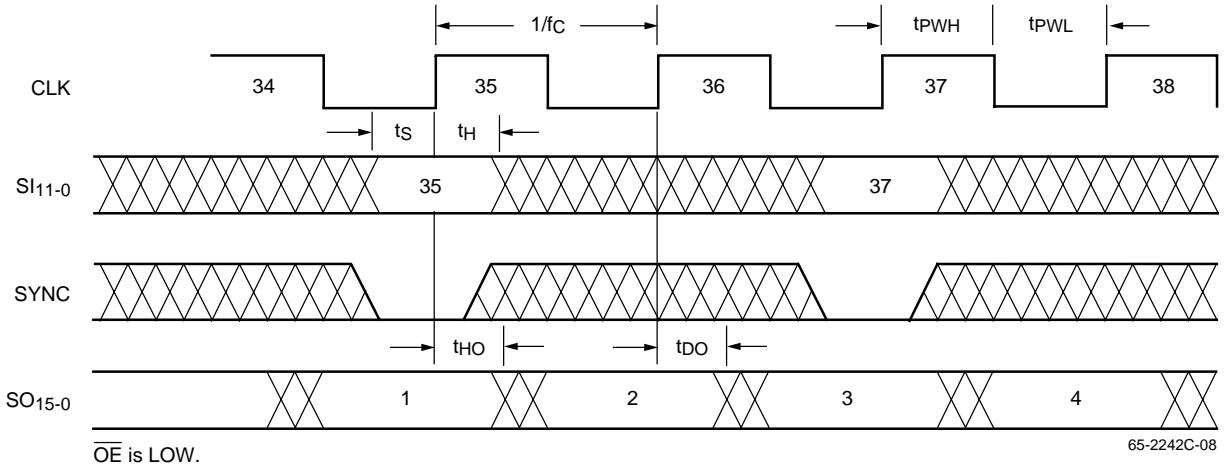

Figure 8. Interpolate Mode

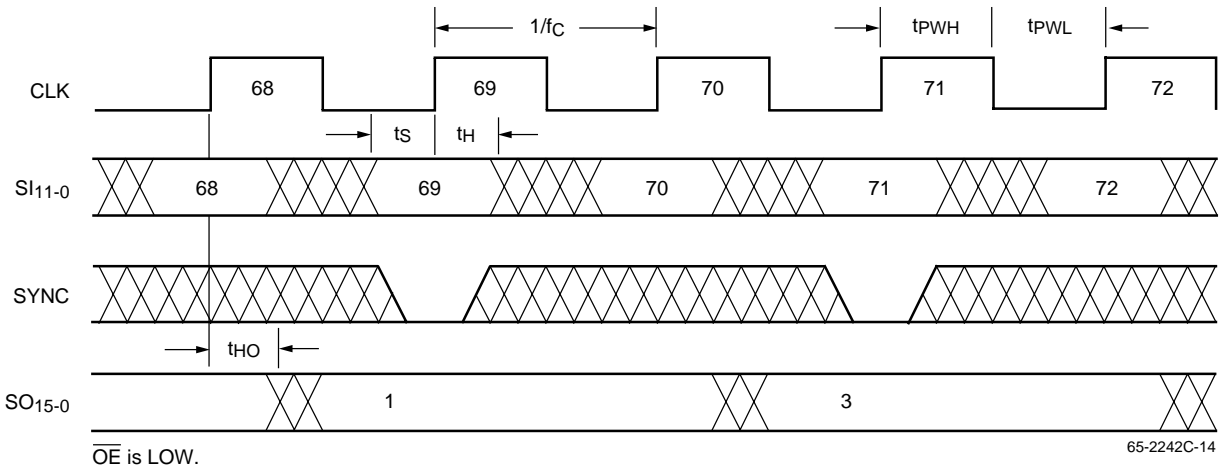

Figure 9. Decimate Mode – Double Latency

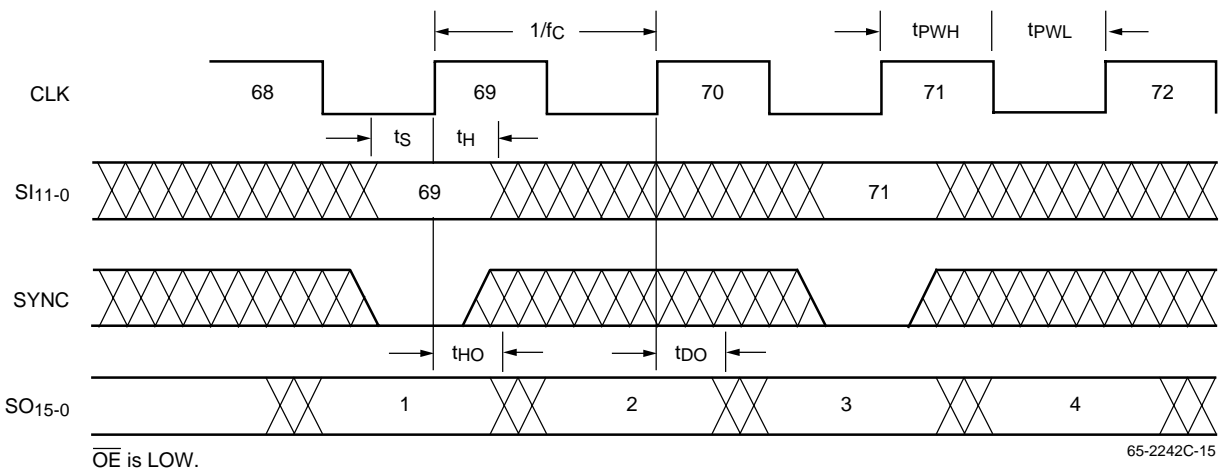

Figure 10. Interpolate Mode – Double Latency

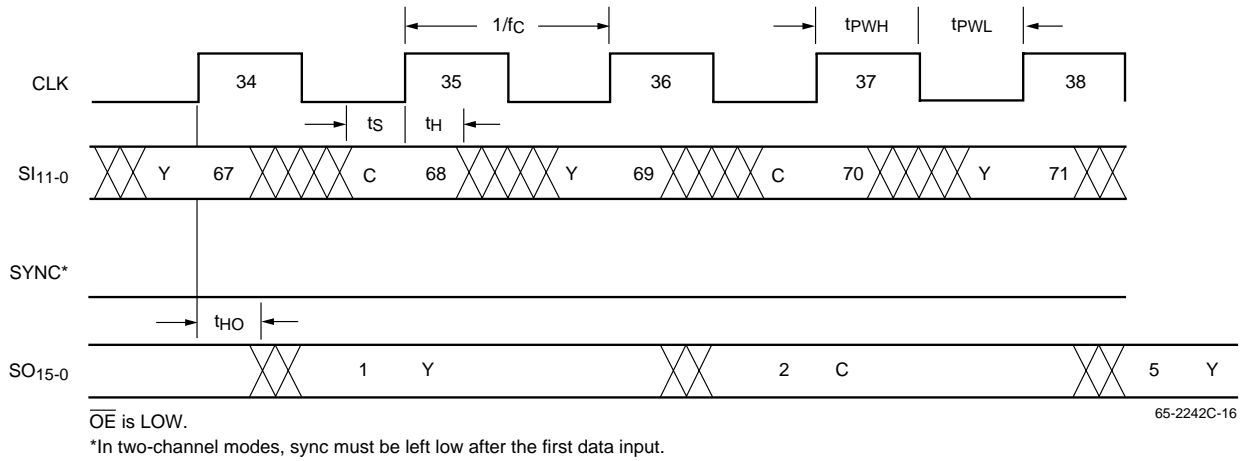

Figure 11. Decimate Mode – Two-Channel

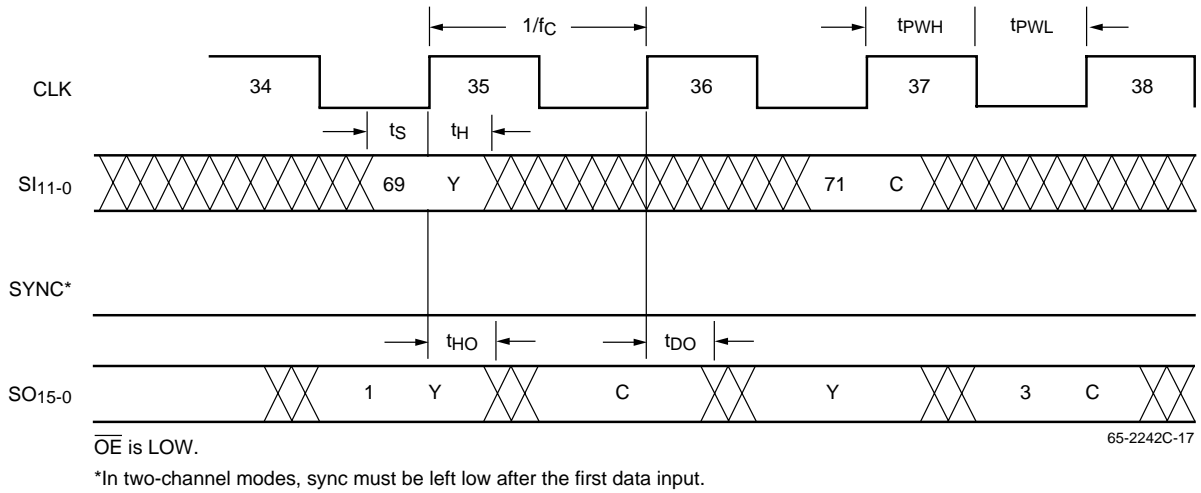

Figure 12. Interpolate Mode – Two-Channel

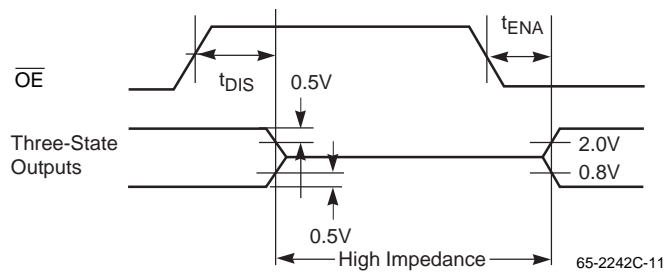

Figure 13. Threshold Levels for Three State Measurements

Applications Discussion

The TMC2242C is well-suited to filtering digitized composite or component NTSC or PAL video. In Figure 14, the TMC1175A 8-bit video A/D converter outputs, D7-0, are connected to the TMC2242C inputs, SI11-4, respectively. To minimize noise and any chance of electrostatic damage, inputs SI3-0 should be grounded. Controls RND2-0 are set to 100 and SO1 is forced high to effect 8-bit rounding. SO3-2, TCO, and DEC are forced low, whereas INT and SO0 are forced high. (Setting SO0 high and TCO low selects unsigned binary format at the input and output data ports, eliminating the need for external MSB inverters.)

In Figure 15, the TMC2242C drives a fast D/A converter to reconstruct analog composite video. The TMC3003 10-bit digital-to-analog converter inputs, D9-0, are connected to the TMC2242C outputs SO15-6, respectively. The TMC2242C RND2-0 controls are set to 110 for rounded 10-bit interpolation operation.

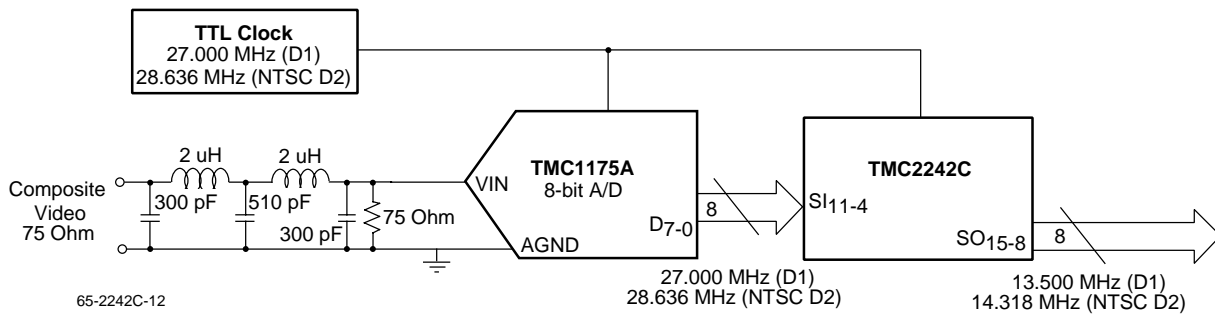
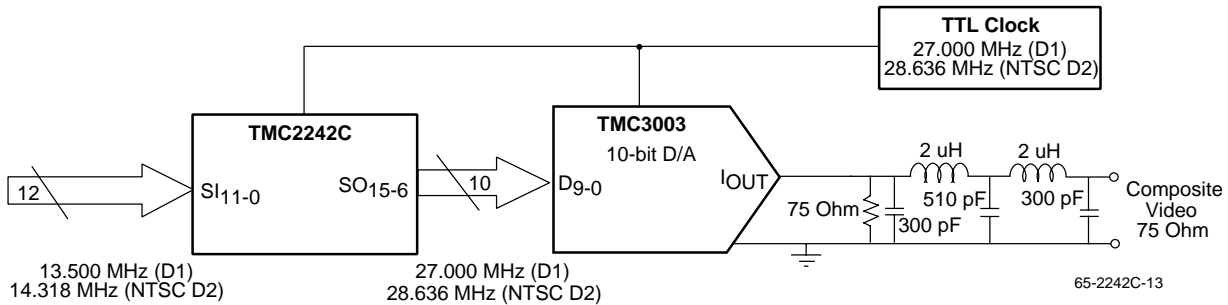

Figure 12. Decimating Oversampled Video With a Low Cost 8-bit A/D

TCO = 0 RND = 100 SO(3:0) = 0011 DEC = 0 INT = 1



Note: Data buses are unsigned binary.

Figure 13. Interpolating Digital Video Signals before Reconstruction

TCO = 0 RND = 110 SO(3:0) = 0011 DEC = 0 INT = 0

Notes:

Mechanical Dimensions – 44-Pin PLCC Package

nbol	Inches		Millimeters		Notes
	Min.	Max.	Min.	Max.	
	.165	.180	4.19	4.57	
	.090	.120	2.29	3.05	
	.020	—	.51	—	
	.013	.021	.33	.53	
	.026	.032	.66	.81	
	.685	.695	17.40	17.65	
E1	.650	.656	16.51	16.66	3
E3	.500 BSC		12.7 BSC		
	.050 BSC		1.27 BSC		
	.042	.056	1.07	1.42	2
NE	11		11		
	44		44		
	—	.004	—	0.10	

Notes:

1. All dimensions and tolerances conform to ANSI Y14.5M-1982
2. Corner and edge chamfer (J) = 45°
3. Dimension D1 and E1 do not include mold protrusion. Allowable protrusion is .101" (.25mm)

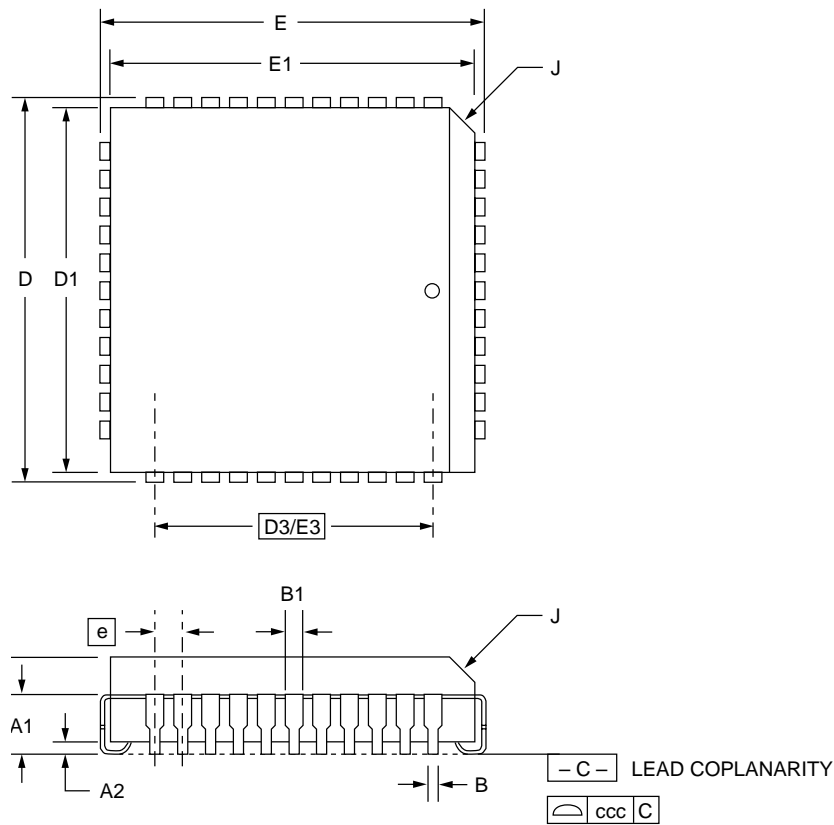

Mechanical Dimensions – 44-Lead MQFP Package

Symbol	Inches		Millimeters		Notes
	Min.	Max.	Min.	Max.	
A	.077	.093	1.95	2.35	
A1	.000	.010	.00	.25	
A2	.077	.083	1.95	2.11	
B	.012	.018	.30	.46	7
C	.005	.009	.13	.23	
D/E	.510	.530	12.95	13.45	
D1/E1	.390	.398	9.90	10.10	2
e	.032 BSC		.81 BSC		
L	.026	.037	.66	.94	6
N	44		44		4
ND	11		11		5
α	0°	7°	0°	7°	
ccc	—	.004	—	0.10	

Notes:

1. All dimensions and tolerances conform to ANSI Y14.5M-1982.
2. Dimensions "D1" and "E1" do not include mold protrusion.
3. Pin 1 identifier is optional.
4. Dimension N: number of terminals.
5. Dimension ND: Number of terminals per package edge.
6. "L" is the length of terminal for soldering to a substrate.
7. "B" includes lead finish thickness.

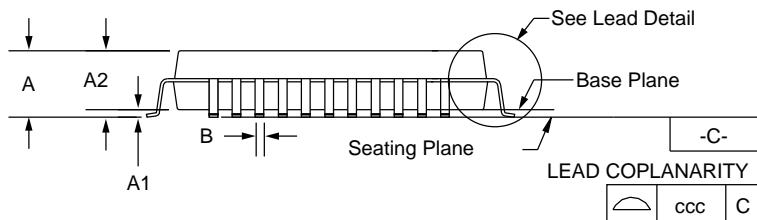
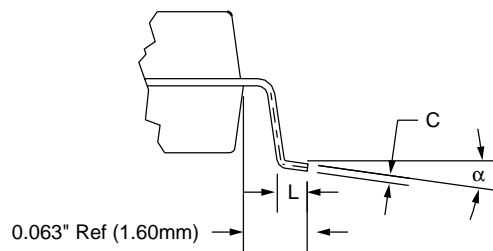
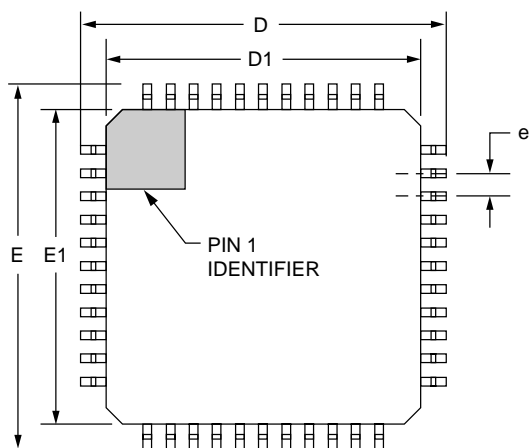

Ordering Information

Product Number	Temperature Range	Speed Grade	Screening	Package	Package Marking
TMC2242CR2C	0°C to 70°C	40 MHz	Commercial	44-Lead PLCC	2242CR2C
TMC2242CR2C1	0°C to 70°C	60 MHz	Commercial	44-Lead PLCC	2242CR2C1
TMC2242CKTC	0°C to 70°C	40 MHz	Commercial	44-Lead MQFP	2242CKTC
TMC2242CKTC1	0°C to 70°C	60 MHz	Commercial	44-Lead MQFP	2242CKTC1

DISCLAIMER

FAIRCHILD SEMICONDUCTOR RESERVES THE RIGHT TO MAKE CHANGES WITHOUT FURTHER NOTICE TO ANY PRODUCTS HEREIN TO IMPROVE RELIABILITY, FUNCTION OR DESIGN. FAIRCHILD DOES NOT ASSUME ANY LIABILITY ARISING OUT OF THE APPLICATION OR USE OF ANY PRODUCT OR CIRCUIT DESCRIBED HEREIN; NEITHER DOES IT CONVEY ANY LICENSE UNDER ITS PATENT RIGHTS, NOR THE RIGHTS OF OTHERS.

LIFE SUPPORT POLICY

FAIRCHILD'S PRODUCTS ARE NOT AUTHORIZED FOR USE AS CRITICAL COMPONENTS IN LIFE SUPPORT DEVICES OR SYSTEMS WITHOUT THE EXPRESS WRITTEN APPROVAL OF THE PRESIDENT OF FAIRCHILD SEMICONDUCTOR CORPORATION. As used herein:

1. Life support devices or systems are devices or systems which, (a) are intended for surgical implant into the body, or (b) support or sustain life, or (c) whose failure to perform when properly used in accordance with instructions for use provided in the labeling, can be reasonably expected to result in significant injury to the user.
2. A critical component is any component of a life support device or system whose failure to perform can be reasonably expected to cause the failure of the life support device or system, or to affect its safety or effectiveness.