

CMPT651
SURFACE MOUNT
NPN HIGH CURRENT TRANSISTOR

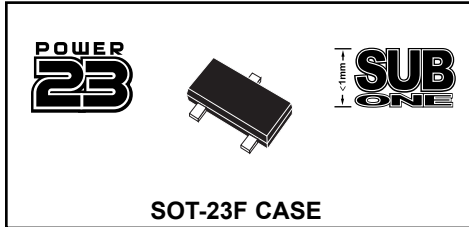

CentralTM
Semiconductor Corp.

DESCRIPTION:

The CENTRAL SEMICONDUCTOR CMPT651 type is a high current NPN Silicon Transistor, epoxy molded in a space saving Power SOT-23F surface mount package, designed for high current applications.

Marking code is **C651**.

MAXIMUM RATINGS: ($T_A=25^\circ\text{C}$)

Collector-Base Voltage
Collector-Emitter Voltage
Emitter-Base Voltage
Collector Current
Power Dissipation
Operating and Storage
Junction Temperature
Thermal Resistance

SYMBOL		UNITS
V_{CB0}	80	V
V_{CE0}	60	V
V_{EB0}	5.0	V
I_C	2.0	A
P_D	350	mW
T_J, T_{stg}	-65 to +150	$^\circ\text{C}$
θ_{JA}	357	$^\circ\text{C/W}$

ELECTRICAL CHARACTERISTICS: ($T_A=25^\circ\text{C}$)

SYMBOL	TEST CONDITIONS	MIN	MAX	UNITS
I_{CBO}	$V_{CB}=80\text{V}$		100	nA
I_{EBO}	$V_{EB}=4.0\text{V}$		100	nA
BV_{CBO}	$I_C=100\mu\text{A}$	80		V
BV_{CEO}	$I_C=10\text{mA}$	60		V
BV_{EBO}	$I_E=10\mu\text{A}$	5.0		V
$V_{CE(SAT)}$	$I_C=0.5\text{A}, I_B=50\text{mA}$		100	mV
$V_{CE(SAT)}$	$I_C=1.0\text{A}, I_B=100\text{mA}$		200	mV
$V_{CE(SAT)}$	$I_C=2.0\text{A}, I_B=200\text{mA}$		400	mV
$V_{BE(SAT)}$	$I_C=1.0\text{A}, I_B=100\text{mA}$		1.2	V
$V_{BE(ON)}$	$V_{CE}=2.0\text{V}, I_C=1.0\text{A}$		1.0	V
h_{FE}	$V_{CE}=2.0\text{V}, I_C=50\text{mA}$	75		
h_{FE}	$V_{CE}=2.0\text{V}, I_C=500\text{mA}$	100	300	
h_{FE}	$V_{CE}=2.0\text{V}, I_C=1.0\text{A}$	75		
h_{FE}	$V_{CE}=2.0\text{V}, I_C=2.0\text{A}$	40		
f_T	$V_{CE}=5.0\text{V}, I_C=50\text{mA}, f=100\text{MHz}$	75		MHz

R0 (03-January 2002)

SOT-23F CASE - MECHANICAL OUTLINE

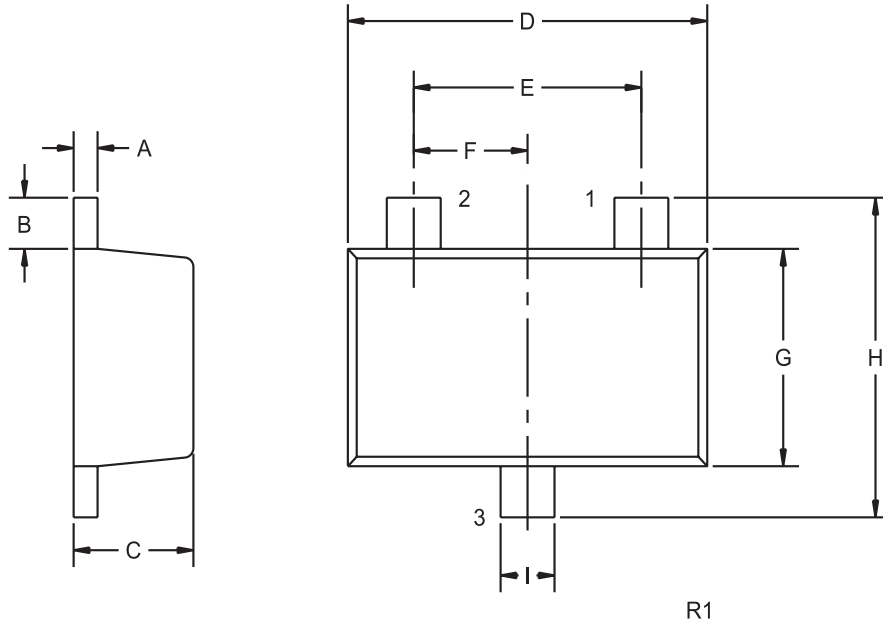

LEAD CODE:

- 1) Base
- 2) Emitter
- 3) Collector

DIMENSIONS				
SYMBOL	INCHES		MILLIMETERS	
	MIN	MAX	MIN	MAX
A	0.004	0.008	0.10	0.20
B	0.012	0.020	0.30	0.50
C	0.031	0.039	0.80	1.00
D	0.110	0.118	2.80	3.00
E	0.075		1.90	
F	0.037		0.95	
G	0.059	0.067	1.50	1.70
H	0.091	0.098	2.30	2.50
I	0.014	0.018	0.35	0.45

SOT-23F (REV: R1)