

3-INPUT 2-OUTPUT VIDEO SWITCH FOR AV-SET

■ GENERAL DESCRIPTION

NJM2279 is 3-input, 2-output video switch with 75Ω driver circuit.

This video switch can be connected to TV monitor directly, as it has 6dB amplifier and 75Ω drivers circuit internally.

The NJM2279 has the mute function.

■ FEATURES

- 3 input 2 output
- Internal 6dB AMP.
- Internal 75Ω Driver Circuit
- Operating Voltage Dual (±4V~)
- Single (+8V~)
- Internal 2 Output Mute Function
- Package Outline DIP14, DMP14
- Bipolar Technology

■ PACKAGE OUTLINE

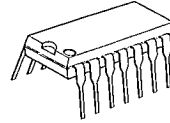

NJM2279D

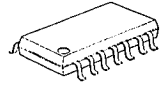

NJM2279M

■ RECOMMENDED OPERATING CONDITION

- | | | |
|------------------|--------|---------------|
| ● Supply Voltage | Dual | ±4.0V ~ ±7.0V |
| | Single | +8V ~ +14V |

■ BLOCK DIAGRAM

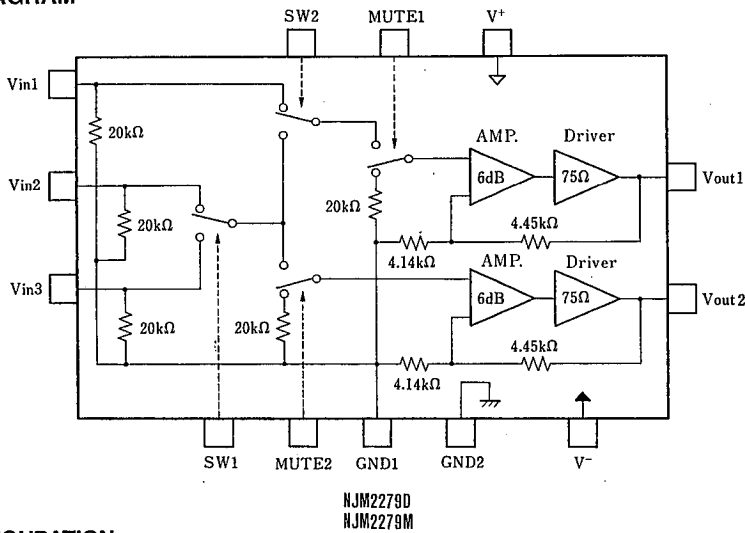

■ PIN CONFIGURATION

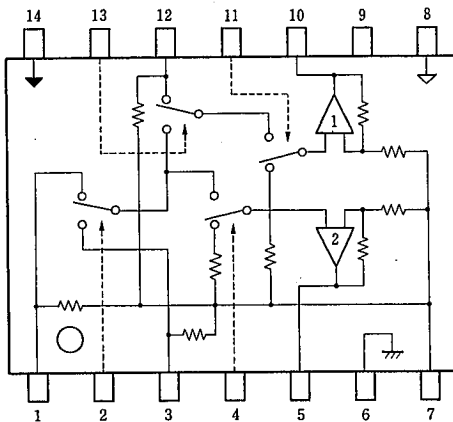

PIN FUNCTION

- | | |
|----------|-----------|
| 1. Vin3 | 8. V+ |
| 2. SW1 | 9. N.C. |
| 3. Vin2 | 10. Vout1 |
| 4. MUTE2 | 11. MUTE1 |
| 5. Vout2 | 12. Vin1 |
| 6. GND2 | 13. SW2 |
| 7. GND1 | 14. V- |

5

■ ABSOLUTE MAXIMUM RATINGS

(Ta=25°C)

PARAMETER	SYMBOL	RATINGS	UNIT
Supply Voltage	V ⁺ /V ⁻	±7.5	V
Power Dissipation	P _D	(DIP14) 700	mW
		(DMP14) 300	mW
Operating Temperature Range	T _{opr}	-20~+75	°C
Storage Temperature Range	T _{stg}	-40~+125	°C

■ ELECTRICAL CHARACTERISTICS

(V⁺/V⁻=±5.0V, R_L=150Ω Ta=25°C)

PARAMETER	SYMBOL	TEST CONDITION	MIN.	TYP.	MAX.	UNIT
Operating Current	I _{CC}	No signal	10.0	17.3	24.6	mA
	I _{EE}	No signal	-24.6	-17.3	-10.0	mA
Voltage Gain	G _V	V _{IN} =100kHz/1.0V _{P-P}	6.0	6.3	6.8	dB
Freguency Characteristic	G _f	5MHz/100kHz, 1.0V _{P-P}	-1.0	0.0	+1.0	dB
Differential Gain	DG	V _{IN} =1.0V _{P-P} Stair wave	—	0.2	—	%
Differential Phase	DP	V _{IN} =1.0V _{P-P} Stair wave	—	0.2	—	deg
Offset output Voltage 1	V _{OS1}	V _{in2} -V _{in3} :no signal	-40	0	+40	mV
Offset output Voltage 2	V _{OS2}	V _{in1} -V _{in2} /V _{in3} :no signal	-60	0	+60	mV
Input/Output Crosstalk	CT	V _{IN} =4.43MHz/1.0V _{P-P} , V _O /V _{IN}	—	-70	—	dB
MUTE Crosstalk	CT _M	V _{IN} =4.43MHz/1.0V _{P-P} , V _O /V _{IN}	—	-60	—	dB
Switch Change Voltage	V _{CH}		2.5	—	V ⁺	V
	V _{CL}		0.0	—	1.0	V
Total Harmonic Distortion	THD	V _{IN} =1kHz 1.25V _{P-P}	—	0.1	—	%
Input Impedance	R _{in}		—	20	—	kΩ



TEST CIRCUIT

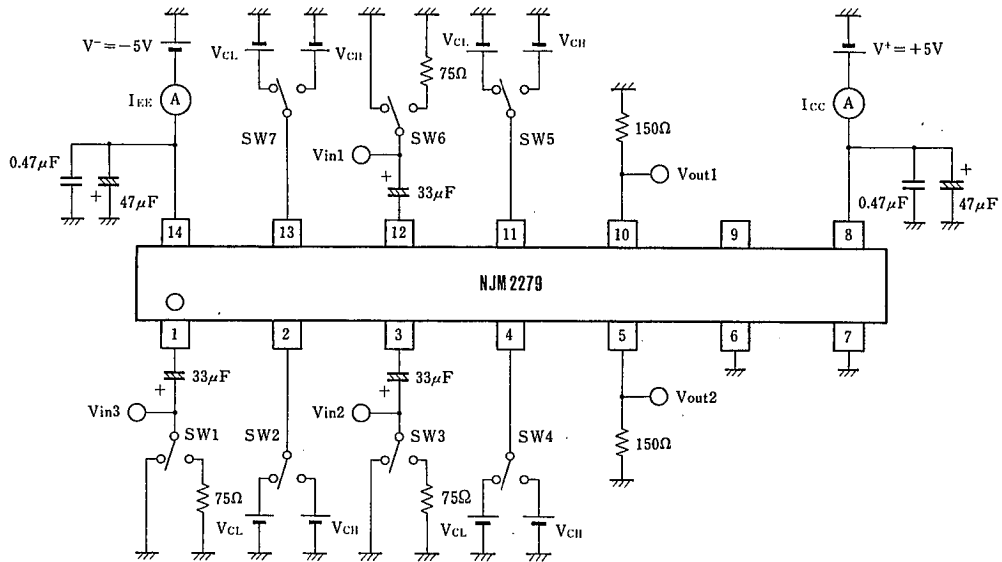

PARAMETER	SYMBOL	UNIT	INPUT TERMINAL	TEST TERMINAL	TEST CONDITION
Operating Current	I_{CC}	mA	—	8 pin	$V_{in 1\sim 3}=0V, SW1/2 \cdot MUTE1/2=V_{CL}$
	I_{EE}	mA	—	14 pin	"
Voltage Gain	G_v	dB	1, 3, 12 pin	5, 10 pin	$MUTE1/2=V_{CL}$
Frequency Characteristic	G_f	dB	1, 3, 12 pin	5, 10 pin	"
Differential Gain	DG	%	1, 3, 12 pin	5, 10 pin	"
Differential Phase	DP	deg	1, 3, 12 pin	5, 10 pin	"
Offset output Voltage 1	V_{os1}	mV	—	5, 10 pin	$V_{in 1\sim 3}=0V$
Offset output Voltage 2	V_{os2}	mV	—	5, 10 pin	$V_{in 1\sim 3}=0V$
Input/Output Crosstalk	CT	dB	1, 3, 12 pin	5, 10 pin	$MUTE1/2=V_{CL}$
MUTE Crosstalk	CT_M	dB	1, 3, 12 pin	5, 10 pin	$MUTE1/2=V_{CL}$
Switch Change Voltage	V_{CH}	V	—	—	
	V_{CL}	V	—	—	
Total Harmonic Distortion	THD	%	1, 3, 12 pin	5, 10 pin	

■ CONTROL SIGNAL-OUTPUT SIGNAL

(L=V_{CL}, H=V_{CH}, X=LorH)

CONTROL SIGNAL				OUTPUT	
SW 1 (2 pin)	SW 2 (13 pin)	MUTE 1 (11 pin)	MUTE 2 (4 pin)	Vout 1 (10 pin)	Vout 2 (5 pin)
X	X	L	L	GND	GND
X	X	L	H	GND	OUT PUT
X	X	H	L	OUT PUT	GND
L	L	H	H	V _{IN 1}	V _{IN 2}
L	H	H	H	V _{IN 2}	V _{IN 2}
H	L	H	H	V _{IN 1}	V _{IN 3}
H	H	H	H	V _{IN 3}	V _{IN 3}

■ APPLICATION

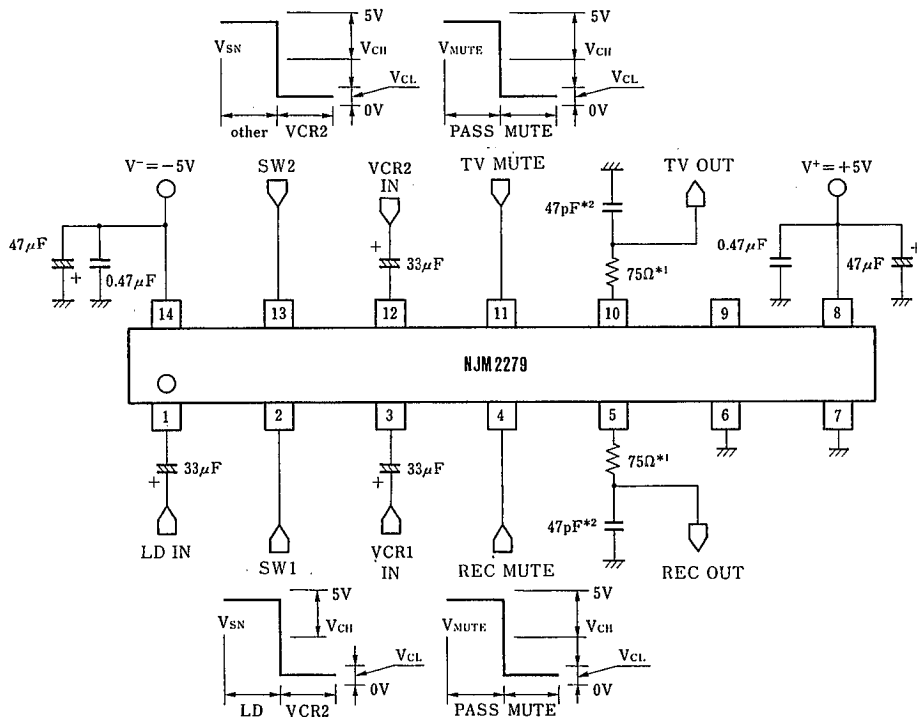

■ TYPICAL CHARACTERISTICS

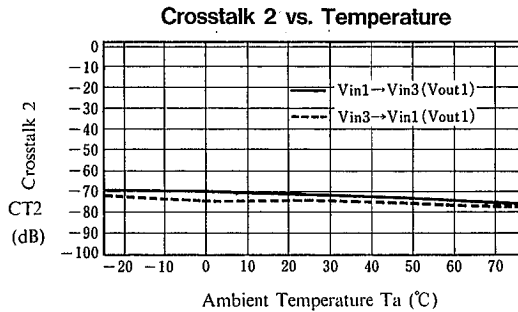
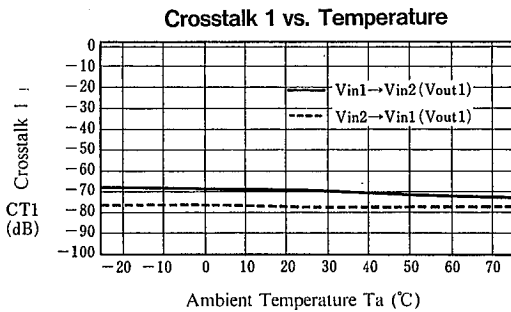
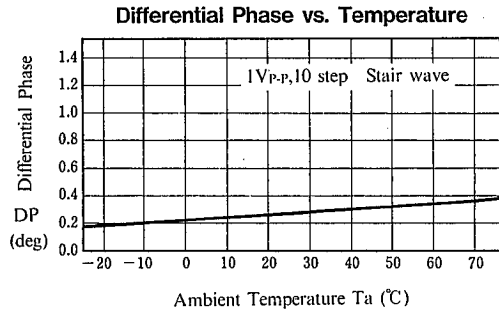
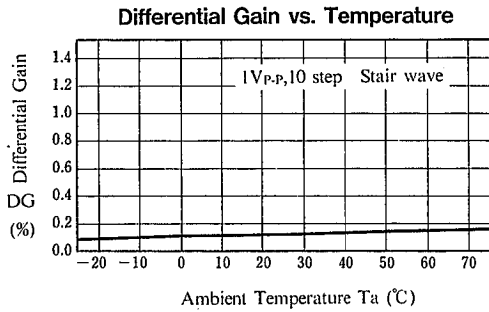
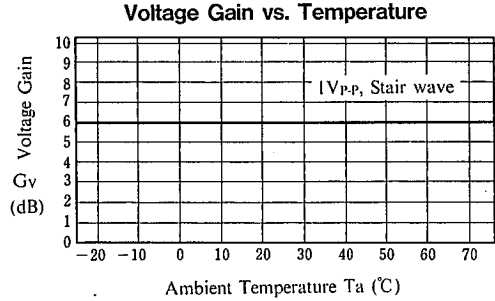
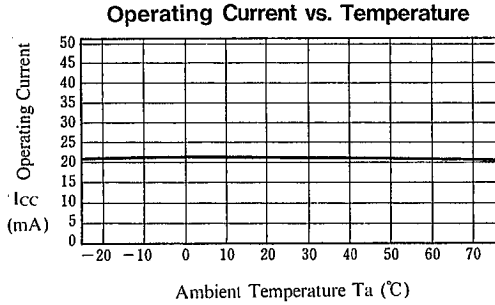

5

■ TYPICAL CHARACTERISTICS

Crosstalk 3 vs. Temperature

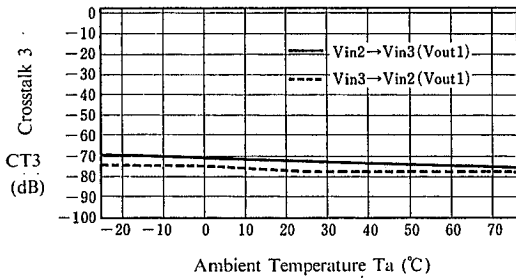

Crosstalk 4 vs. Temperature

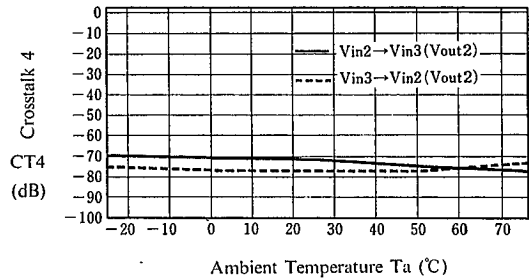

MUTE Crosstalk vs. Temperature

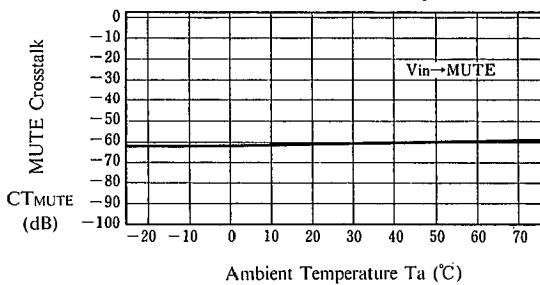

MUTE offset Voltage vs. Temperature

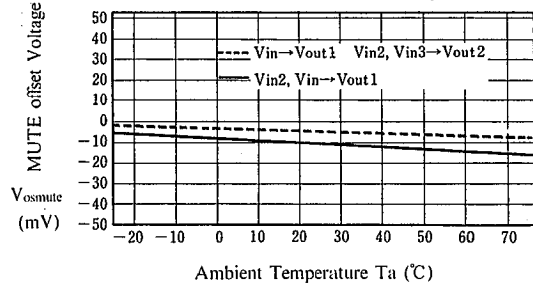

Channel offset Voltage vs. Temperature

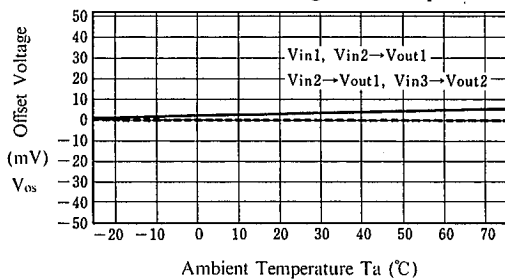

Total Harmonic Distortion vs. Temperature

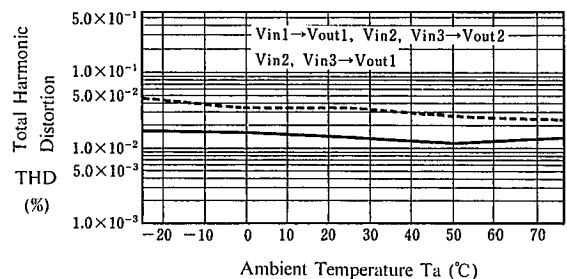

■ TYPICAL CHARACTERISTICS

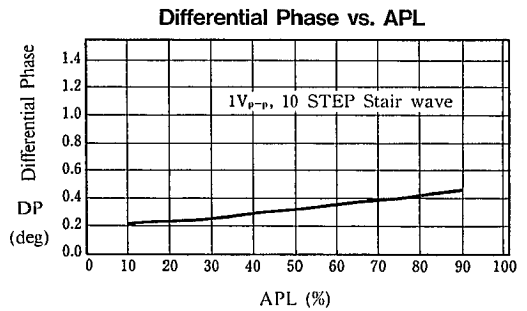
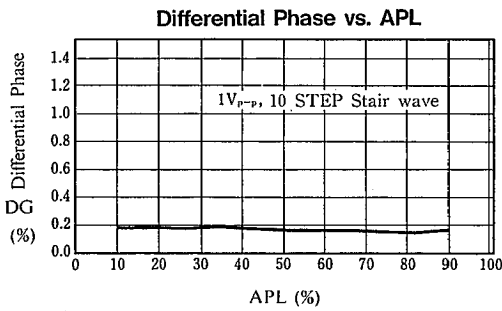
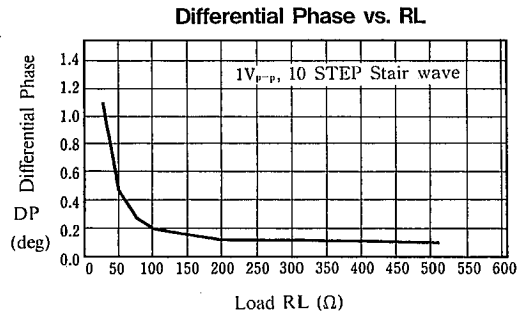
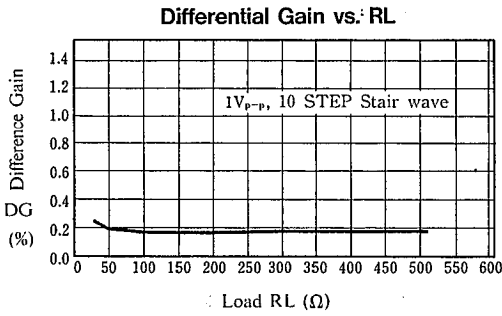
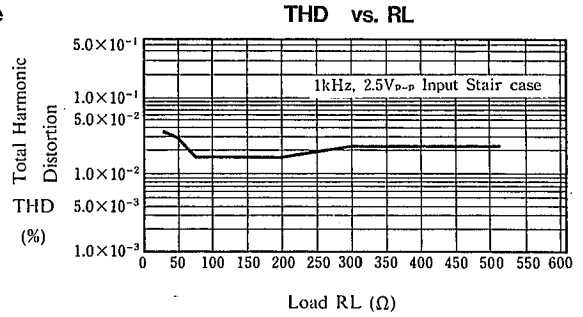
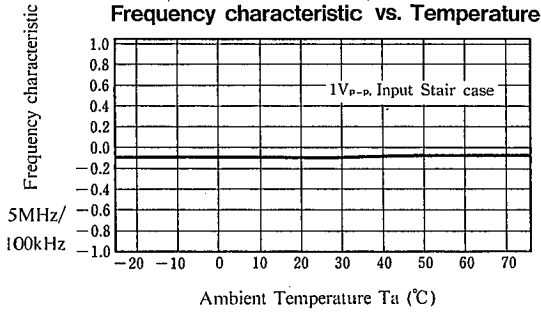

■ TYPICAL CHARACTERISTICS

Operating Current vs. Operating Voltage

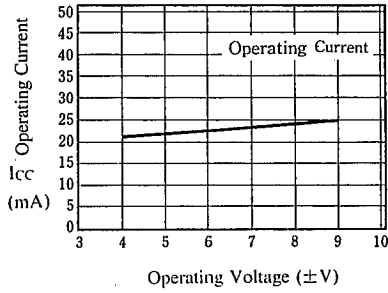

THD vs. Operating Voltage

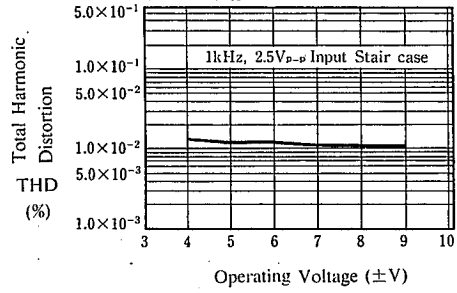

Different Gain vs. Operating Voltage

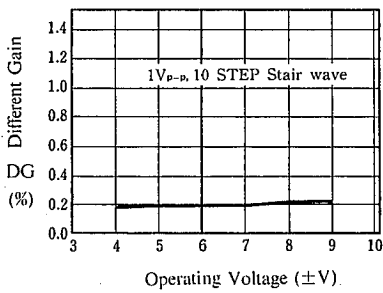

Differential Phase vs. Operating Voltage

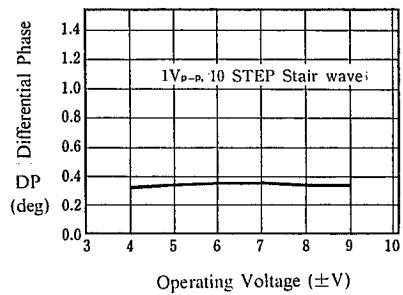

Voltage Gain vs. Frequency

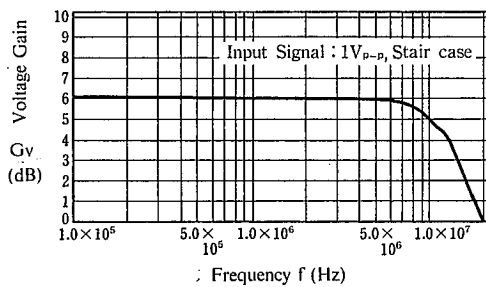

Switching Voltage vs. Operating Voltage

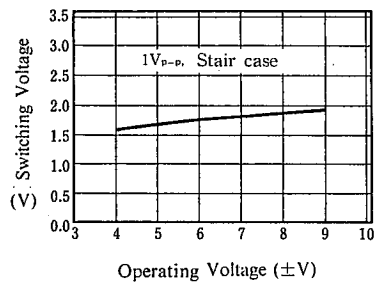

■ TYPICAL CHARACTERISTICS

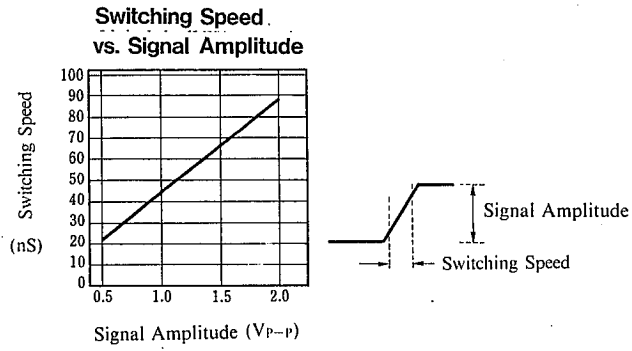

MEMO

[CAUTION]

The specifications on this databook are only given for information, without any guarantee as regards either mistakes or omissions. The application circuits in this databook are described only to show representative usages of the product and not intended for the guarantee or permission of any right including the industrial rights.