

SANYO	No.3195	2SC4400
	NPN Epitaxial Planar Silicon Transistor High-Frequency General-Purpose Amp Applications	

Features

- High power gain
- High cutoff frequency
- Small c_{ob} , c_{re}
- Very small-sized package permitting the 2SC4400-applied sets to be made small and slim

Absolute Maximum Ratings at $T_a = 25^\circ\text{C}$

			unit
Collector to Base Voltage	V_{CBO}	40	V
Collector to Emitter Voltage	V_{CEO}	18	V
Emitter to Base Voltage	V_{EBO}	3	V
Collector Current	I_C	50	mA
Collector Dissipation	P_C	150	mW
Junction Temperature	T_j	150	$^\circ\text{C}$
Storage Temperature	T_{stg}	- 55 to + 150	$^\circ\text{C}$

Electrical Characteristics at $T_a = 25^\circ\text{C}$

			min	typ	max	unit
Collector Cutoff Current	I_{CBO}	$V_{CB} = 18\text{V}, I_E = 0$			0.1	μA
Emitter Cutoff Current	I_{EBO}	$V_{EB} = 2\text{V}, I_C = 0$			0.1	μA
DC Current Gain	h_{FE}	$V_{CE} = 10\text{V}, I_C = 5\text{mA}$	60*		270*	
Gain-Bandwidth Product	f_T	$V_{CE} = 10\text{V}, I_C = 5\text{mA}$		750		MHz
Output Capacitance	c_{ob}	$V_{CB} = 10\text{V}, f = 1\text{MHz}$		0.7	1.2	pF
Reverse Transfer Capacitance	c_{re}	$V_{CB} = 10\text{V}, f = 1\text{MHz}$		0.45		pF
C-E Saturation Voltage	$V_{CE(sat)}$	$I_C = 10\text{mA}, I_B = 1\text{mA}$			0.2	V
B-C Time Constant	$r_{bb}'c_c$	$V_{CE} = 10\text{V}, I_C = 5\text{mA}, f = 31.9\text{MHz}$			23	ps
Power Gain	PG	$V_{CE} = 10\text{V}, I_C = 10\text{mA}, f = 100\text{MHz}$		28		dB

* : The 2SC4400 is classified by 5mA h_{FE} as follows.

60	3	120	90	4	180	135	5	270
----	---	-----	----	---	-----	-----	---	-----

Marking : RT

h_{FE} rank : 3,4,5

PG Test Circuit

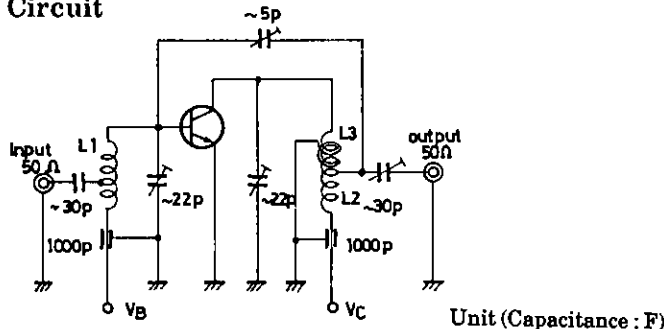

L_1 : 1mm ϕ plated wire, 10mm ϕ 5T, pitch 15mm, tap : 2T from base side

L_2 : 1mm ϕ plated wire, 10mm ϕ 7T, pitch 10mm, tap : 2T from V_C side

L_3 : 1mm ϕ enamel wire, 10mm ϕ 3T, pitch 10mm

Package Dimensions 2059
(unit : mm)

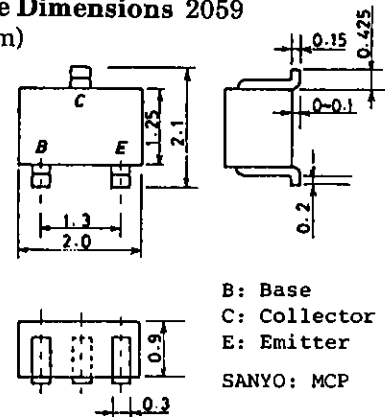

2SC4400

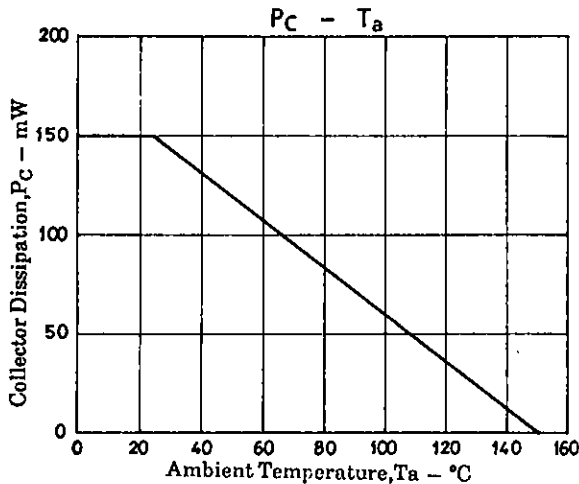
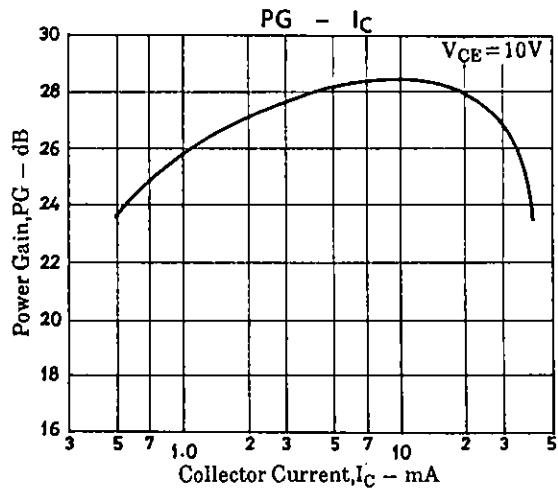
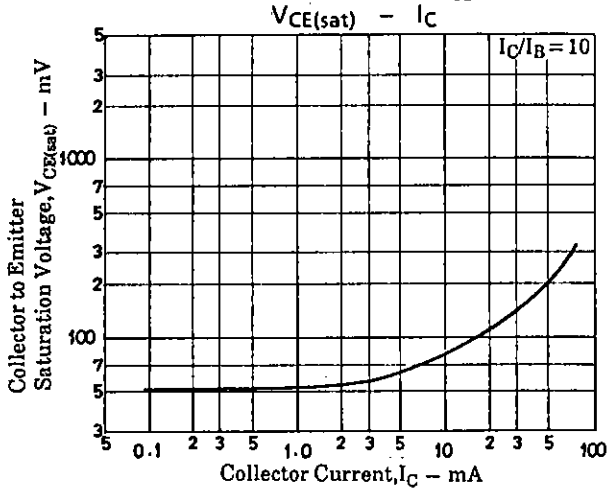
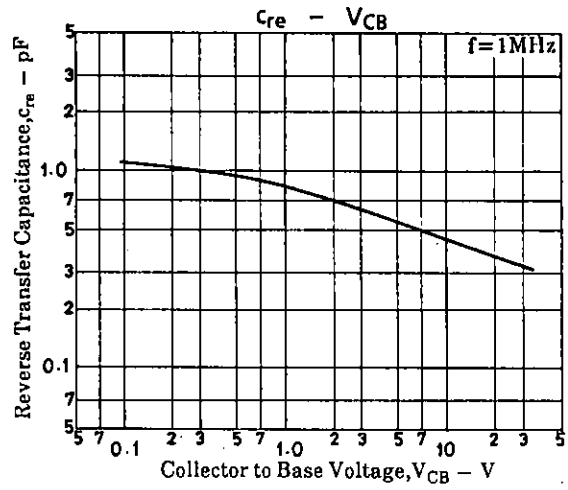
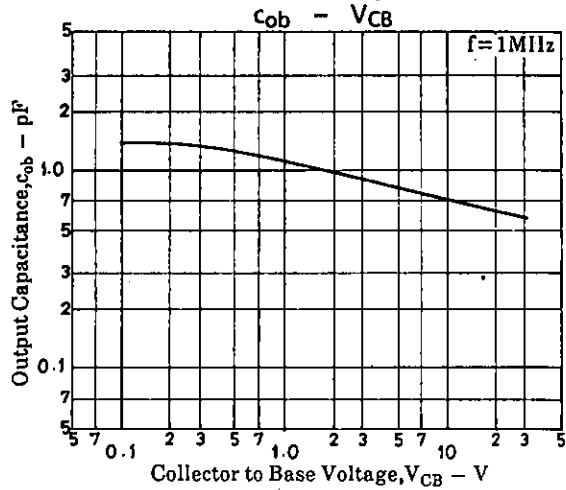
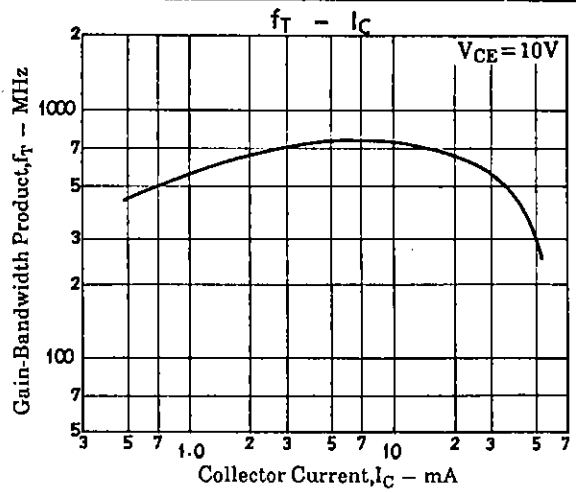
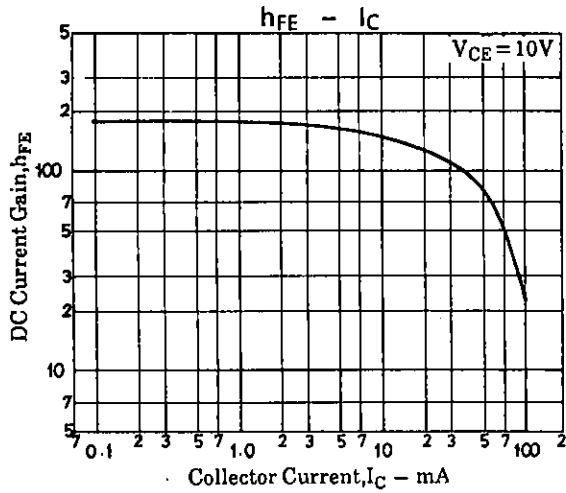

- No products described or contained herein are intended for use in surgical implants, life-support systems, aerospace equipment, nuclear power control systems, vehicles, disaster/crime-prevention equipment and the like, the failure of which may directly or indirectly cause injury, death or property loss.
- Anyone purchasing any products described or contained herein for an above-mentioned use shall:
 - ① Accept full responsibility and indemnify and defend SANYO ELECTRIC CO., LTD., its affiliates, subsidiaries and distributors and all their officers and employees, jointly and severally, against any and all claims and litigation and all damages, cost and expenses associated with such use;
 - ② Not impose any responsibility for any fault or negligence which may be cited in any such claim or litigation on SANYO ELECTRIC CO., LTD., its affiliates, subsidiaries and distributors or any of their officers and employees jointly or severally.
- Information (including circuit diagrams and circuit parameters) herein is for example only; it is not guaranteed for volume production. SANYO believes information herein is accurate and reliable, but no guarantees are made or implied regarding its use or any infringements of intellectual property rights or other rights of third parties.